

MFG: CHANCE RIDES, INC.
NAME: WIPE OUT
TYPE: NON-KIDDIE

CARNYTOWN.COM

WIPEOUT

Field inspection and test guide

Manual number 24329313



CARNYTOWN.COM

CARNYTOWN.COM

CARNYTOWN.COM

CARNYTOWN.COM

WIPEOUT

Field inspection and test guide

Contents

Introduction	2
Ride description	2
Operation	4
Operating controls	4
Operating the ride (test cycle)	6
General inspection and testing	7
Testing	7
Field performance testing of amusement rides	7
Non-destructive testing	9
Fasteners	10
Capscrews	10
Pins	14
Inspection	16
Joint inspection	16
Leveling and blocking	17
General safety guidelines	22
Vehicle inspection	23
Lap bar operational check	26
Sweep inspection	28
Boom and turret inspection	30
Electrical and lighting inspection	31
Trailer inspection	34
Hydraulic system inspection	35
Air system inspection	36
Platform and fence inspection	37
Material handling equipment inspection	39
Bibliography	40

CHANCE RIDES, INC.
4219 Irving
P.O. Box 12328
Wichita, KS 67277-2328

phone (316) 942-7411
fax (316) 942-7416

Introduction

Proper maintenance is essential to the safe operation of this ride. The inspection points outlined in this field inspection guide are not intended to replace the recommended maintenance schedule. This guide does not contain maintenance and repair procedures and should only be used as a ride inspection guide.

When repairs are necessary use only those components authorized, specified or provided by the manufacturer. If any alterations, modifications and/or additions, installations of unauthorized components are made to the original design without the manufacturer's explicit written consent or without direct supervision by a manufacturer's representative, CHANCE RIDES INC., makes no claims as to the integrity of the altered or modified ride (product).

Information in this field inspection guide applies only to products manufactured by CHANCE RIDES INC. built after January 1, 1986.

CHANCE RIDES INC., reserves the right to make improvements in design or changes in specifications at any time without incurring any obligation to such changes.

Ride description

The **Wipeout** is mounted on a single trailer. The ride is equipped with an electro-hydraulic drive with air and hydraulic braking.

The ride information plaque is mounted to the boom support structure on the turret. It lists specifications, operating dimensions, ground loads, as well as model and serial number and date of manufacture.

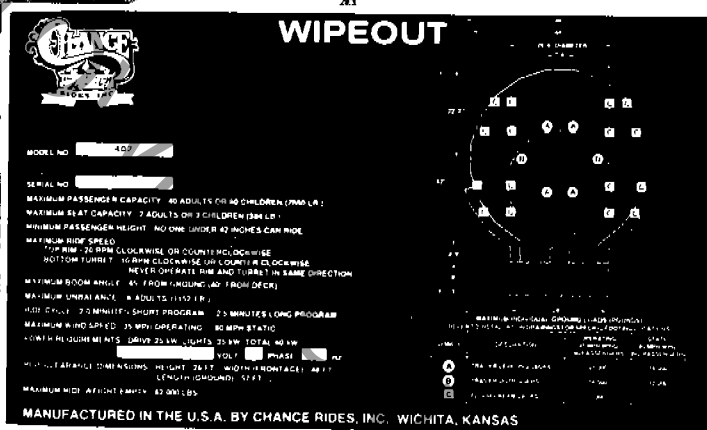
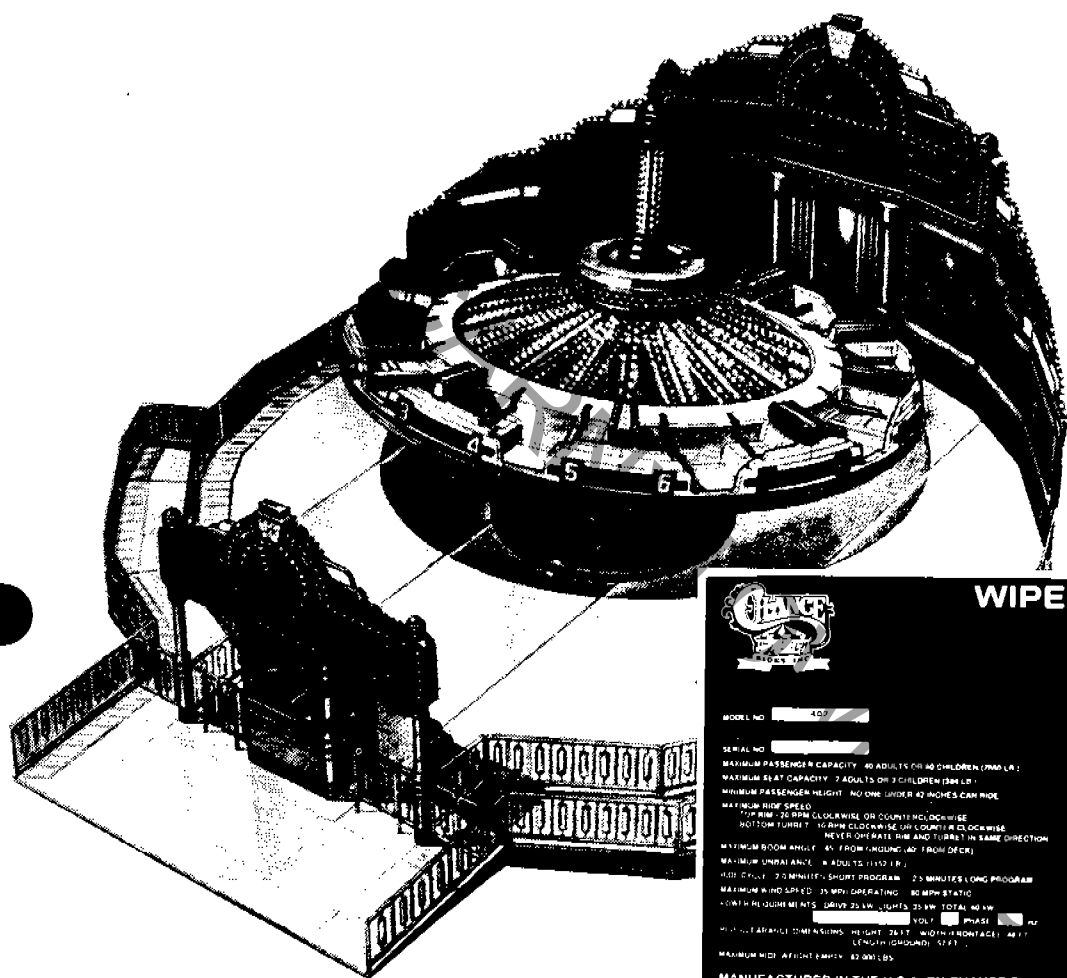

The ride information plaque is mounted to the boom support structure on the turret. The ride information plaque shown is for example only. Always refer to the information plaque mounted to the ride being inspected.

Detailed operation and maintenance information is available in the *Wipeout Service Manual* (manual number 24329311). For more information, or to order manuals, contact CHANCE RIDES, INC.

Operation

Operating controls

1. **Low air pressure alarm and indicator light** - This alarm and red light are normally off. If the air pressure is not sufficient to operator the ride, the alarm and indicator light will come on. Do not start the ride.
2. **Ready light** - This green light will come on when all lap bars are locked in the down position and the operator presence switch is depressed (the pump switch must also be on). The ride cannot be started until this light is on.
3. **Power switch** - Use this switch to turn off the main power circuit breaker in the motor control cabinet. The MAIN POWER INDICATOR LIGHT will go out when this switch is used.
4. **Pump switch** - Use this switch to turn the hydraulic pump either on or off. The pump must be on to run the ride.
5. **Light switch** - Use this switch to control all the decorative lighting on the ride.
6. **Main power indicator light** - This white light is on when the main power circuit breaker in the motor control cabinet is in the "ON" position.
7. **Flood light switch** - Use this switch to control all the flood lights on the ride.
8. **Short/long program switch** - Use this key-operated switch to select either the short or long programmed ride cycle. Do not change the program switch after the ride is started.
9. **E-stop switch** - This switch interrupts the drive program. The ride will come to a normal, programmed stop.

Operating controls

1. Low air pressure alarm and indicator light
2. Ready light
3. Power switch
4. Pump switch
5. Light switch
6. Main power indicator light
7. Flood light switch
8. Short/long program switch
9. E-stop switch
10. Start switch
11. Rim jog switch
12. Turret jog switch
13. Boom jog switch
14. Operator presence switch

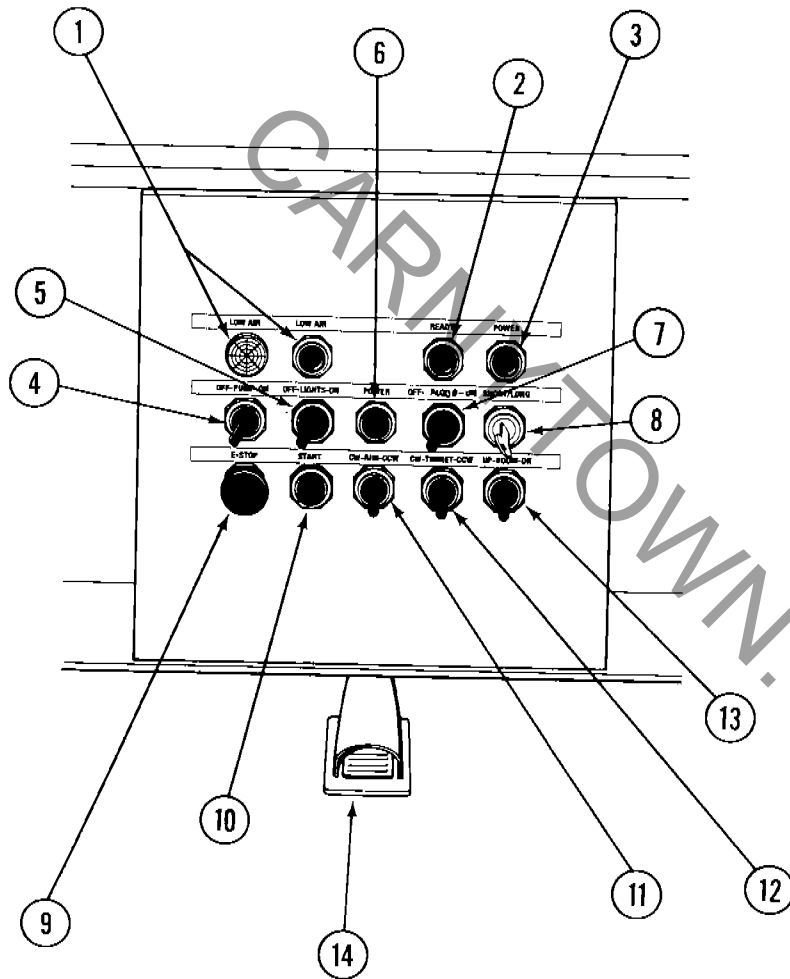

10. Start switch - Use this switch to start the programmed ride cycle. The following conditions must exist for the ride to operate:

- Main power indicator light must be on.
- Operator presence switch must be depressed.
- Ready light must be on.

11. **Rim jog switch** - The rim jog feature allows the operator to rotate the rim to any position. The operator presence switch must also be depressed.
12. **Turret jog switch** - The turret jog feature allows the operator to rotate the turret to any position. The operator presence switch must also be depressed.
13. **Boom jog switch** - The boom jog feature allows the operator to raise the boom at any position. The operator presence switch must also be depressed.

NOTE: The boom jog feature will operate if one or more of the lap bars is not down and locked.

14. **Operator presence switch** - This foot switch must be depressed to operate the start or jog buttons. If the switch is released, the drive program is interrupted and the ride will come to a normal, programmed stop.

Operating the ride (test cycle)

The operation procedure is provided on a decal, mounted next to the control console inside the control house. Make sure this decal is legible. Test the operation of all controls. Throughout the ride cycle, check for correct speed and boom angle, and proper brake operation.

Check the overall performance of the ride based on previous operating performances of the individual ride.

General inspection and testing

Testing

Field performance testing of amusement rides¹

The following specifications conform with ASTM F846 standard guide for *Testing Performance Of Amusement Rides And Devices*, in effect on date of ride manufacture.

Erection or installation testing

Each erection or installation of a ride shall be given an inspection prior to carrying passengers that shall include but not be limited to the following:

- a. Determine that ride has been erected according to the set-up procedures in the operations manual.
- b. Inspect field inspection points listed in the *Field Inspection Guide*.
- c. Visual check of all passenger carrying devices including restraint devices and latches, and the pins and capscrews securing them.
- d. Visual inspection of entrances, exits, stairways and ramps and devices securing them.
- e. Test of all communications equipment necessary for operation of the ride or device.
- f. Operate the ride to determine that direction of travel conforms to the information plate, ride manual field inspection guide of specification sheet.
- g. Operate the ride for a minimum of three ride cycles to determine that the ride speed does not exceed the speed specified in the information plate, ride manual, field inspection guide, or specification sheet.

Daily pre-opening inspection

This inspection shall include a daily inspection of all items as specified in the previous item (erection or installation testing).

Documented field performance and operational testing

Documentation and certification shall be performed by a person who by demonstrated education and field experience is knowledgeable with construction, erection, operation, maintenance and repair of amusement rides.

Operational load testing

Any operational test including load testing performed on a ride shall be completely non-destructive in nature. Overload testing exceeding the rated limits listed on the information plate, operation manual, field inspection guide or specification sheet shall be deemed inappropriate. Where maximum total passenger weight is not readily available, passenger capacity multiplied by 170 pounds per adult and/or 90 pounds per child may be used.

Non destructive testing with inert loads can be accomplished only with special care as to placement of the load so that it is centered both vertically and horizontally as would be the load of the passenger it replaces. Extra seat reinforcement must be used to offset any load concentration created. Such tests shall be documented and certified as non-destructive by the person making the test and the agency requiring it. Results of all load tests shall be communicated to the factory upon completion by the certifying agency.

Conducting a non-destructive operational load test assures the testing agency only that it will carry a given load in a given way at a given moment and in no way assures future safety of the ride.

Conducting a destructive load or overload test also assures the testing agency that it will carry a given load in a given way at a given moment and in no way assures future safety of the ride. However, it also introduces the probability of inflicting serious irreparable damage to the ride that may or may not be apparent at the time of the test.

CHANCE RIDES, INC. considers inert load testing of any nature appropriate only for situations requiring experimental development of stress-strain testing during prototype development. A certificate of load test on the prototype and certification that each production ride met the design criteria when it was manufactured is available from the factory upon request.

Non-destructive testing²

- REFERENCE** 1. *ASTM-F24 Standard On
STANDARD Amusement Rides And Devices*
- a. *F846-86 Testing Performance Of
Amusement Rides*
 - b. *F853-86 Maintenance Procedures
For Amusement Rides And Devices*
 - c. *F893-87 Inspection Of Amusement
Rides And Devices*

CHANCE RIDES, INC., at the time of design and manufacture, determines by calculations and testing of a prototype amusement ride the appropriateness for use, of not only the parts, but the entire system of a newly designed ride. These calculations and tests are utilized to, as feasibly as possible, determine the requirements for expected design life of major components. Based on this design criteria, CHANCE RIDES, INC. does not identify critical components on amusement rides to be singled out for non-destructive testing.

If through field experience, there is an indication that a structural or mechanical problem may develop on rides currently operating, CHANCE RIDES, INC. will notify owners by bulletin of the recommended procedures to inspect and correct the possible problem. Any possible defect which could affect the continued safe or proper operation of the ride should be reported immediately to the manufacturer by the owner/operator. This information is necessary so that a determination can be made for either the repair or replacement of the possible defective parts.

Field repairs should not be undertaken without the approval and proper instructions from the manufacturer and should be performed by qualified personnel. These persons should have a complete understanding of both the component's function and the manufacturer's instructions.

It is the responsibility of the individual inspector to thoroughly inspect the ride as he deems necessary based on his knowledge and field experience and manufacturer's recommendations. If the inspector finds an area or component that could be a problem, structural or otherwise, the factory should then be notified. It is then the responsibility of the inspector to ensure that the manufacturer's recommendations for repair,

replacement or otherwise have been completed and are in compliance with the required specifications.

Load testing is a destructive form of testing and is not recommended by the manufacturer, as per previous topic "Field performance testing of amusement rides."

Fasteners

Capscrews

Capscrews used by CHANCE RIDES, INC. are classified as functional load-carrying capscrews if:

- They're used as tension members in the erection or operation of the ride

and/or

- They're required to resist shear through friction-type connections in the erection or operation of a ride.

Capscrews are selected with consideration to grade, size and quantity, using joint capacities based on tightness torques of 60% rated yield and group joint efficiencies of 62.5%

Torque requirements⁴

Capscrews must be tightened to the torque values listed in the torque chart. These values were selected to produce a tightening torque range of 60% to 70% of proof load, when tightened with a hardened washer under the nut or capscrew head (whichever is accessible for tightening). When the capscrew is tightened from the head end, apply anti-seize lubricant to the shank end of the capscrew. When the threads are lubricated, use 10% less torque to tighten the capscrew.

DO NOT TIGHTEN CAPSCREWS OVER THE RECOMMENDED TORQUE. This can damage the capscrew, due to variances in coefficients of friction and torque wrench accuracy.

Always use a torque wrench. It is impossible to accurately measure the tightness of a capscrew by other methods. Torque wrenches must be checked for accuracy twice each operating season.

Size Diameter - Threads/inch	Foot pound torque range (see notes 1 and 2) with locknut and hardened washer	
	SAE J429 Grade 5 ASTM A325	SAE J429 Grade 8 ASTM A490
1/4 - 20	5-6	7-8
1/4 - 28	6-7	8-10
5/16 - 18	11-13	15-18
5/16 - 24	12-15	17-21
3/8 - 16	19-24	27-33
3/8 - 24	22-27	31-38
7/16 - 14	30-35	45-55
7/16 - 20	35-40	50-60
1/2 - 13	50-60	65-80
1/2 - 20	55-65	75-90
5/8 - 11	95-115	130-160
5/8 - 18	105-130	150-180
3/4 - 10	165-200	235-285
3/4 - 16	185-225	260-320
7/8 - 9	270-325	380-460
7/8 - 14	295-360	415-505
1 - 8	400-490	565-690
1 - 12	440-535	620-755
1 1/8 - 7	495-600	800-975
1 1/8 - 12	555-675	900-1095
1 1/4 - 7	700-850	1135-1380
1 1/4 - 12	775-940	1255-1525
1 1/2 - 6	1215-1480	1975-2395
1 1/2 - 12	1370-1660	2220-2700

Torque chart

Torques for functional load carrying cold finished hex head capscrews with dry rolled threads, used with locknuts (see note 3), and tightened with an ASTM A325 hardened washer under the capscrew or locknut head (whichever is accessible for tightening).

This torque range will develop 60% to 70% of proof load.

Refer to **Replacement of capscrews and locknuts** for conditions requiring replacement

NOTES

- 1 Use anti-seize lubricant on capscrew shank when tightened from head end.
2. Use 10% less torque when anti-seize or other lubricant is used on threads.
3. Use same torque range for holes tapped in steel.











Capscrew grades

CHANCE RIDES, INC. uses only grade 5 or better capscrews and grade 8 locknuts, with A325 hardened washers for functional loads. The *Grade markings chart* shows the capscrew markings to be found on CHANCE rides. The manufacturer's identification symbols must be present on all functional load carrying capscrews.

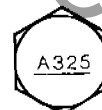
CHANCE RIDES, INC. requires the use of cold-formed hex head capscrews with rolled threads. Hex bolts and hot formed hex head capscrews are not recommended because they may have machined threads and can have die seams along the shank.

NEVER REPLACE CAPSCREWS OR NUTS WITH PARTS OF A LESSER GRADE, OR DIFFERENT LENGTHS THAN THOSE SHOWN IN THE CHANCE PARTS CATALOG.

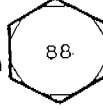
Grade markings for functional load carrying capscrews
 Manufacturer's identification symbols must be present on all capscrews

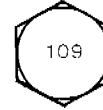
Correct markings	Examples of unacceptable markings	
<p>SAE J429 Grade 5 Medium carbon 81,000 yield</p> 	 <p>Grade 5.1 Low carbon</p>	 <p>Grade 5.2 Low carbon martensitic</p>
<p>ASTM A325 Type 1 Medium carbon Longer shank and shorter thread length than Grade 5 81,000 yield</p>  <p>ASTM A325 Type 3 Corrosion resisting Longer shank and shorter thread length than Grade 5 81,000 yield</p> 	 <p>ASTM A325 Type 2 Low carbon martensitic</p>	
<p>SAE J429 Grade 8 Medium carbon 130,00 yield</p> 	 <p>ISO R898 Class 8.8 Medium carbon 92,000 yield</p>	
<p>ASTM A490 Alloy steel Longer shank and shorter thread length than Grade 8 130,00 yield</p> 	 <p>ISO R898 Class 10.9 Alloy steel 130,000 yield</p>	

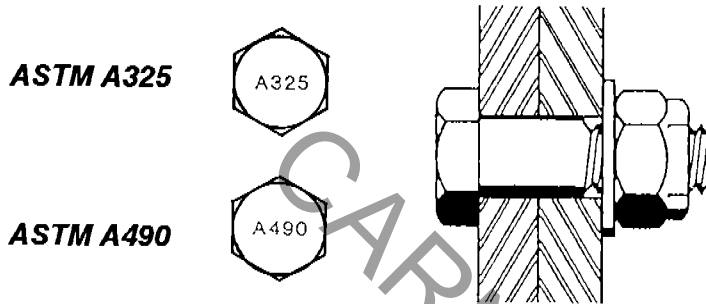

Capscrew comparison
 ATSM A325 and A490 capscrews have longer shanks and shorter threads than Grade 5 and Grade 8 capscrews of the same size.

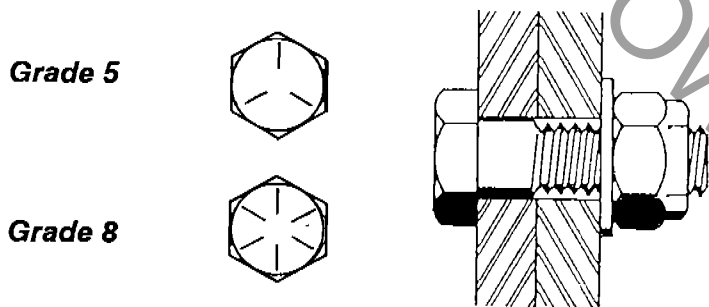

Replacement of capscrews and locknuts

When permanently installed capscrews and locknuts are disassembled for repair or adjustment, they must be replaced if they have been in service over five (5) years, or corrosion, or other damage requires over-torquing for removal. If a torque wrench is not used to measure excessive removal torques, the capscrews and locknuts must be replaced.

Capscrews and locknuts which are frequently disassembled for portability must be replaced each operating season. If the capscrews and locknuts become damaged, corroded or require excessive torque for removal, they must be replaced. If a torque wrench is not used to measure excessive removal torques, the capscrews and locknuts must be replaced.

Pins³

Tapered pins used on amusement rides are subject to deterioration due to improper use and wear. CHANCE RIDES, INC. specifies certain pins for certain applications on amusement rides. These pins have been developed over a period of years, taking into account size, design, material and hardness characteristics.

Use only the pins specified by CHANCE RIDES, INC. These pins are identified as shown in the following illustration. Always use the correct hairpin.

Pin identification

1. Date of manufacture
2. Rounded edges

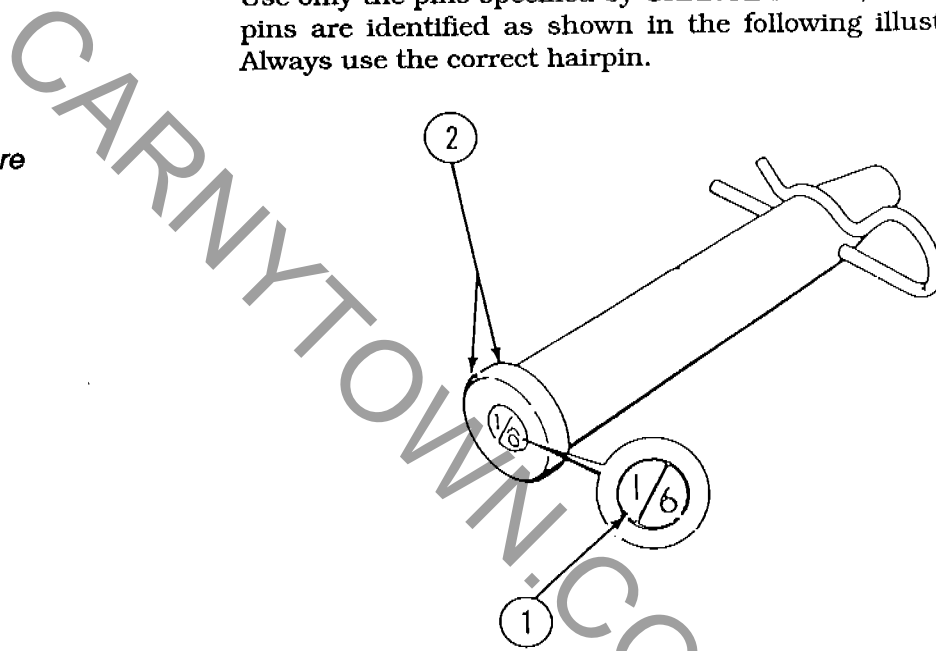

Use care when installing and removing tapered pins. Since these pins are hardened (as are hammers and punches) care must be taken to strike the pin straight on. Striking a pin at an angle can cause the pin to chip, resulting in personal injury. For this reason APPROVED SAFETY GLASSES OR GOGGLES MUST BE WORN AT ALL TIMES when tapered pins are being installed or removed. If a tapered pin is chipped, bent, or "mushroomed" on either end, discard it and replace it with a new pin.

Pin keepers

All keepers (R-keys, hair pins, lynch pins, etc.) must be inspected for wear. If a keeper is bent out of shape or "sprung", it must be replaced.

Hairpins are expendable parts. After repeated use, they become worn and "sprung" as shown.

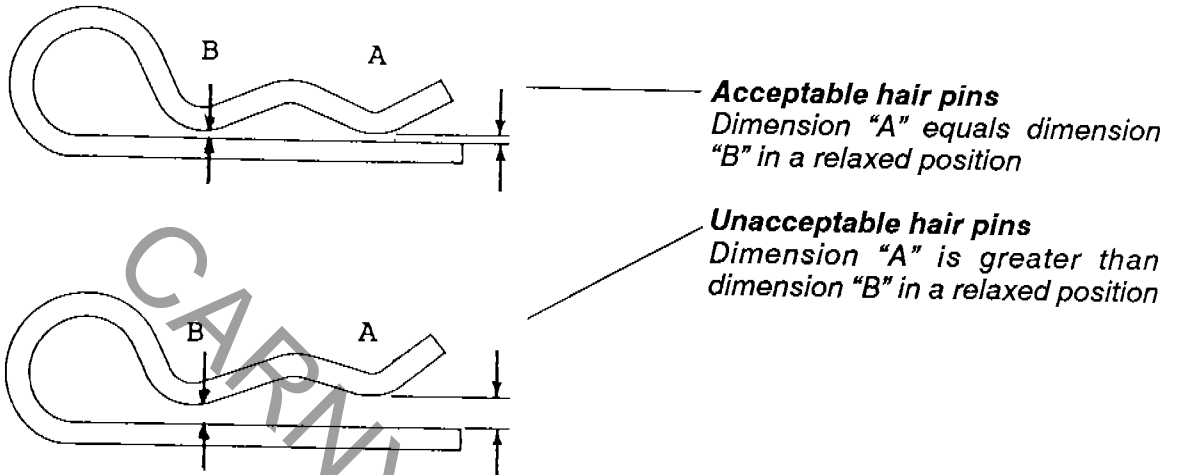

NEVER ATTEMPT TO BEND A HAIR PIN BACK INTO SHAPE.
REPLACE IT WITH A NEW PART.

The correct installation of a hairpin is shown. Incorrectly installed hairpins are more likely to fail, and will distort after only a few uses.

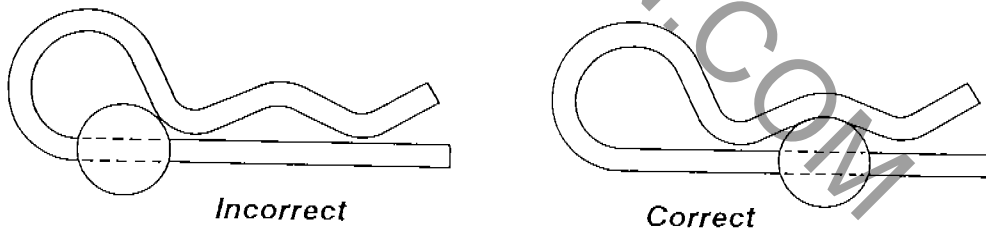

CHANCE RIDES, INC. recognizes and recommends the safety procedures specified in *ASTM Standards F770 Operation Procedures for Amusement Rides and Devices* and *F853 Maintenance Procedures for Amusement Rides and Devices*.

Inspection

Joint inspection

Some joints will appear to wear rapidly on new rides. This is usually a result of the holes not aligning in the mating parts. When this condition occurs it results in "point contact". A joint with this condition will generally wear rapidly until the load is distributed evenly over the fastener and the parts.

If in doubt about the condition of a bolt, pin or hole on a new ride consult CHANCE RIDES, INC., and replace as required.

1. Inspect stationary joints for "egg-shaped" wear and loose pins.

1. Stationary joint wear
2. Stationary joint-misaligned holes resulting in point contact

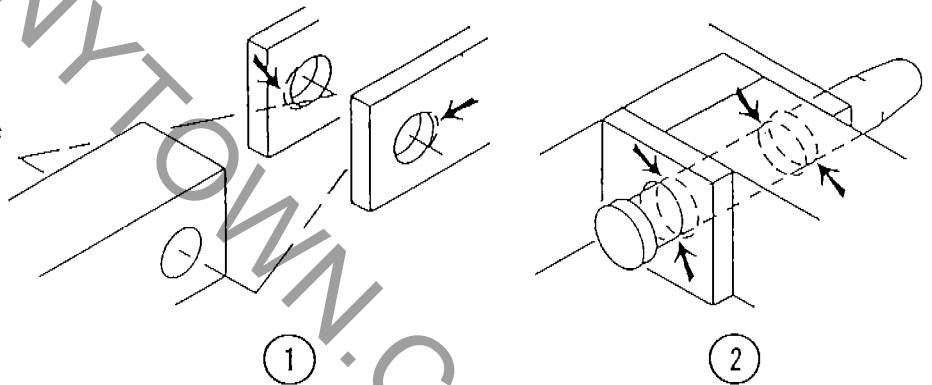

2. Inspect moving joints for wear and lubrication.
3. Inspect welded structural joints for cracking or fatiguing.
4. Inspect bolted structural joints for cracking, fatiguing and proper bolt tightness.
5. Inspect pins and keepers on all pin joints for wear and proper installation.
6. Inspect all pins for proper CHANCE identification marks.

Leveling and blocking

1. Inspect leveling and blocking at each set up and at the start of each day (rides erected in soft locations require more frequent inspection).
2. Inspect for proper cross blocking at each jack location. Cross blocking distributes weight evenly.

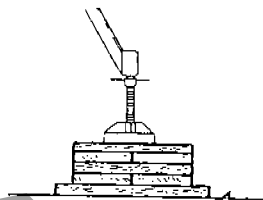
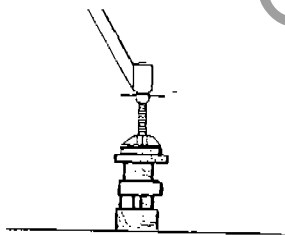

Always cross block
Cross blocking distributes weight evenly.

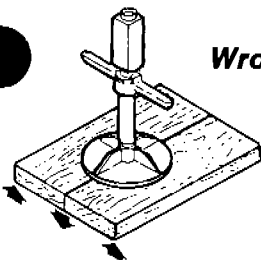

Wrong

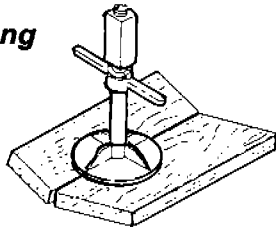

Correct

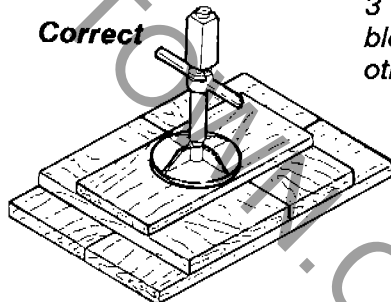

3 X 12 X 36" and 3 X 12 X 24" blocking is recommended unless otherwise instructed.

Support leg blocking

- One block 3 X 12 X 36" minimum

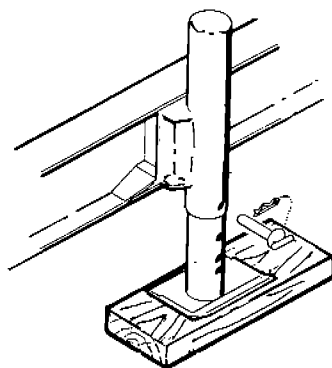

Front leveling jack blocking

- One block 3 X 12 X 24" minimum

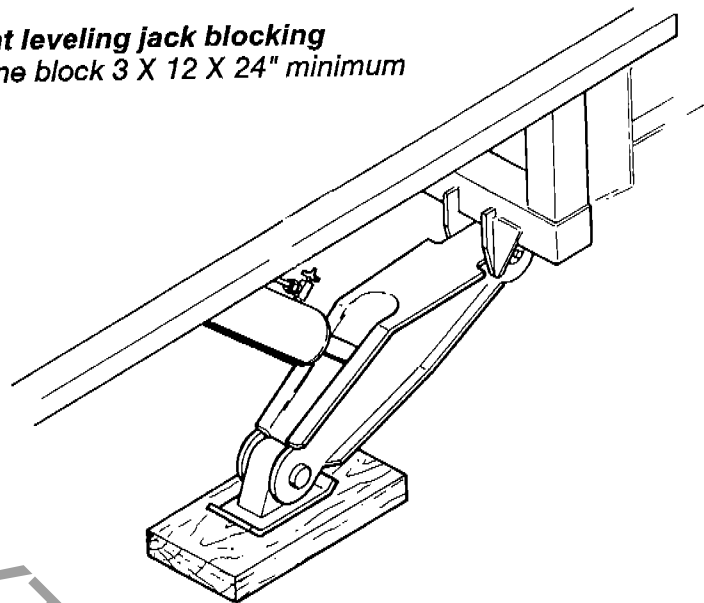

Front screw jack blocking

- Minimum two blocks high
- 3 X 12 X 36" and 3 X 12 X 24"
- Stagger blocks as shown to clear support leg
- Roding pin and hairpin

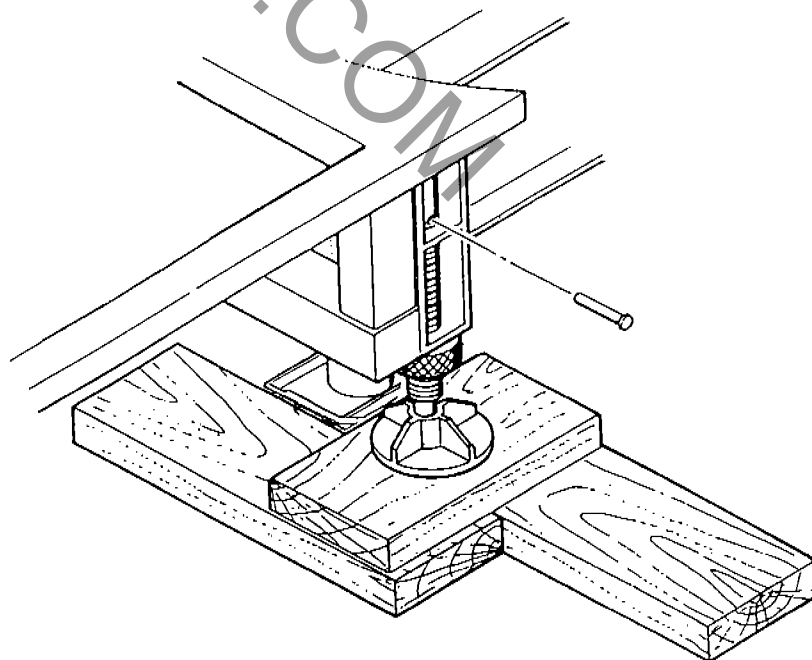

Rear screw jack blocking

- Minimum four blocks high
- 3 X 12 X 36" and 3 X 12 X 24"
- Cross block as shown

Rear leveling jack blocking

- Minimum two blocks high
- 3 X 12 X 36" and 3 X 12 X 24"
- Stack blocks to clear cross blocking under rear screw jacks as shown

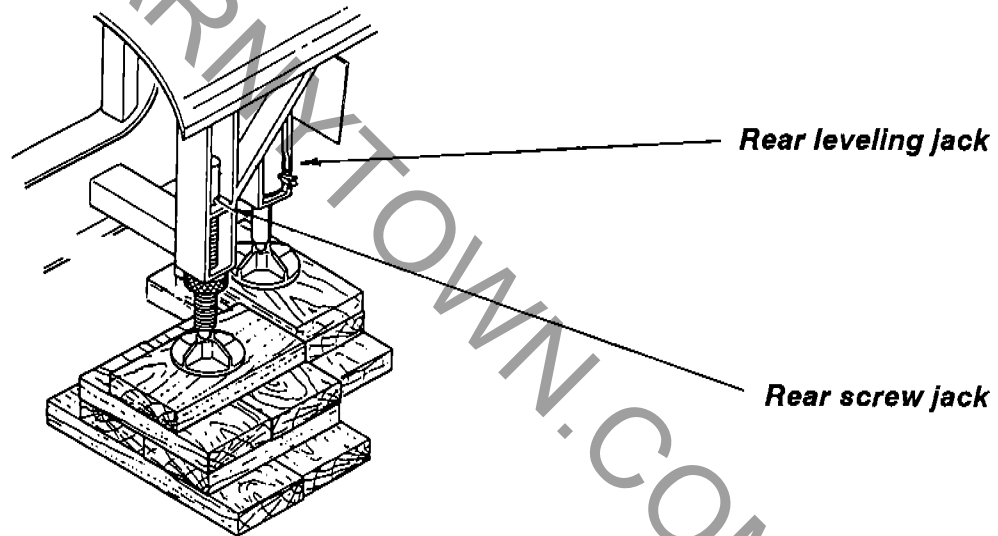

Outrigger blocking

- One block 3 X 12 X 36" Minimum

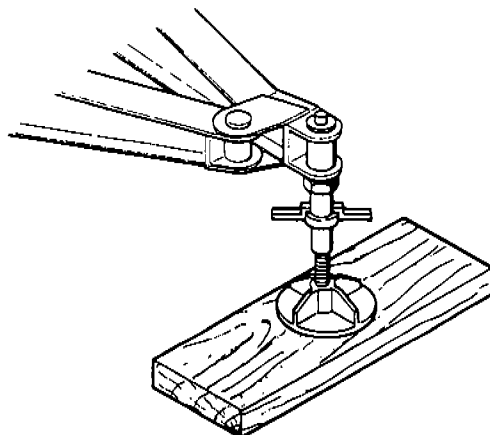

3. Inspect blocking for proper contact with ground.
4. Level ground under blocking by digging where possible, instead of filling. Fill dirt will be soft and allow settling.

Blocking on a slope

Level the ground beneath blocking by digging where possible. Don't fill, the fill dirt will be soft allowing the ride to tilt

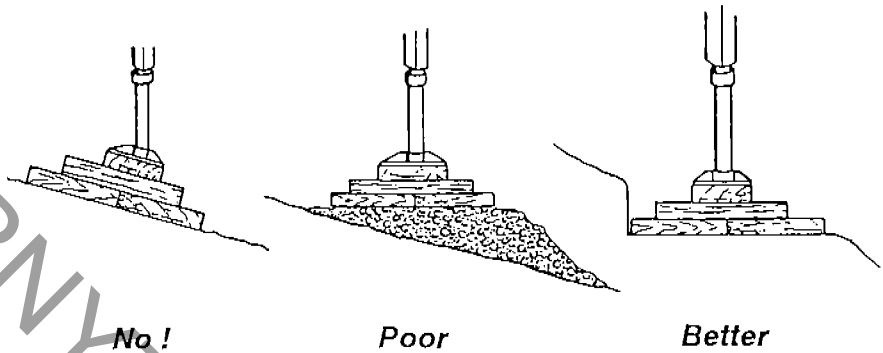

5. Inspect hydraulic leveling jacks for leaks at every set-up. The hydraulic jacks are for leveling purposes only. Make sure that all four screw jacks are on solid blocking and the jack nuts are tightened. Retract the jacks completely and close the shut-off valves so the entire weight of the ride is on the screw jacks.

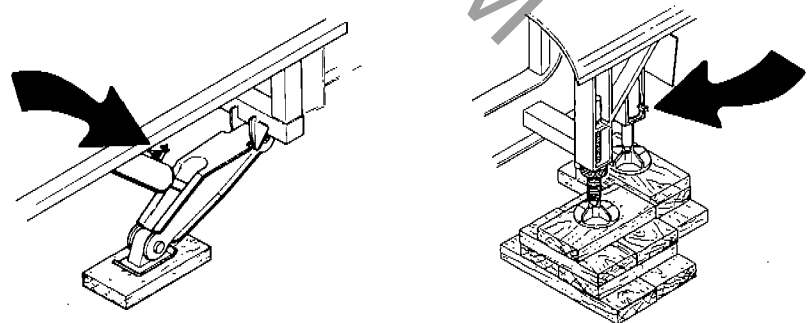

Front and rear leveling shut-off valves

6. Check the jack nuts on screw jacks for tightness.

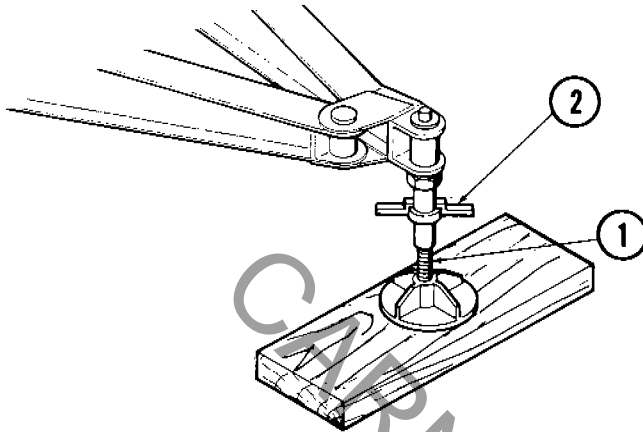

- 1. Screw jack
- 2. Jack nut

7. Check for installation of safety decal at each hydraulic jack and at the jack control valves.

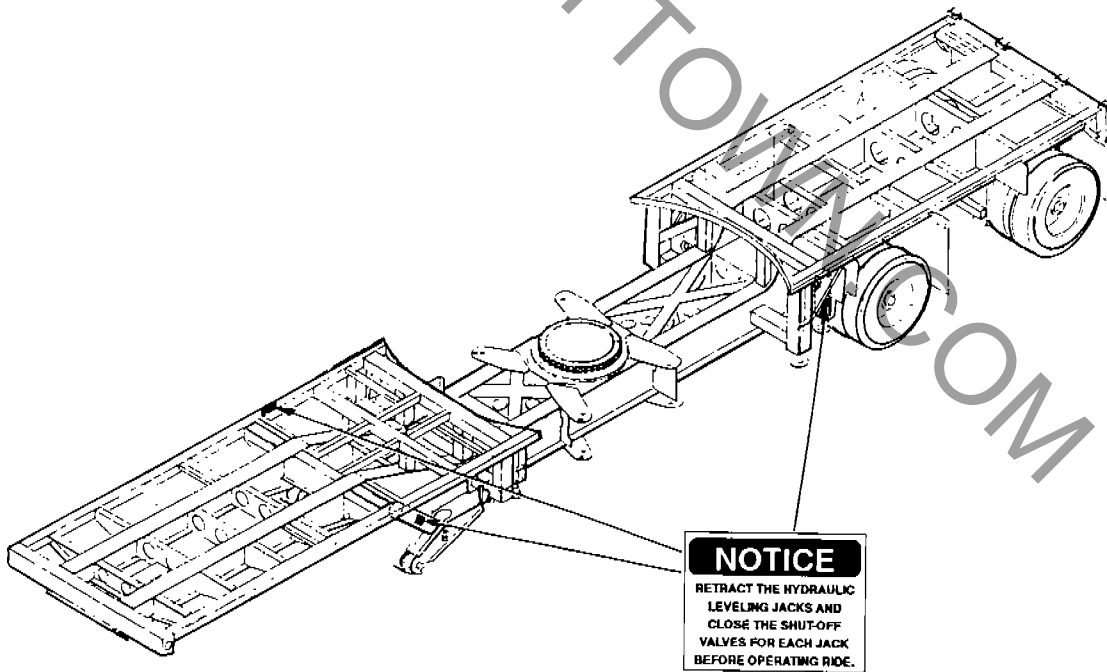

General safety guidelines

The following is a list of general safety rules to which everyone should adhere.

1. All work must be performed by competent, qualified mechanics, capable of understanding the function of the parts and their proper installation.
2. Inspect the ride before each day of operation to determine that no portion of the ride is damaged, missing or worn in such a manner that unsafe conditions can develop.
3. Perform the manufacturer's recommended maintenance procedures at the intervals and in the manner specified in the operation and maintenance manual.
4. Study each job carefully to determine all hazards so that necessary safety precautions can be taken.
5. Examine safety devices (tools, ladders, etc.) before used to insure they are in good condition. Use only OSHA approved safety items. Ladders must be clean and unpainted.
6. Use the proper tool or equipment for each job. All hand electric power tools must be properly grounded.
7. Wear close fitting, comfortable clothing when working on or near moving parts or live electrical circuits. Avoid finger rings, jewelry or other articles which can be caught in moving parts or come in contact with electrical circuits.
8. Protect eyes by wearing approved safety glasses or goggles.
9. Wear a hard hat at all times. When working in elevated areas, use a safety belt.
10. Where work performed is hazardous, never work alone.
11. If guards are removed from equipment, make sure they are replaced before leaving the job.
12. Clean up after each job, disposing of surplus materials.
13. Keep a record of parts replaced and the date of replacement. Inform the manufacturer of any replacement requirements which are frequent or cause unsafe conditions.

14. Make modifications and additions only as outlined in manufacturer's service and safety bulletins.

Vehicle inspection

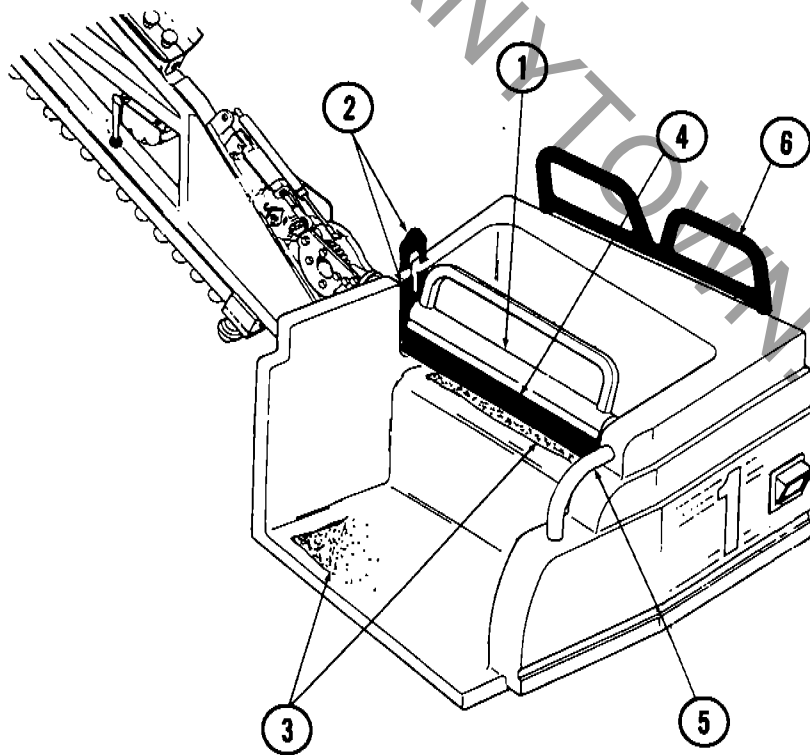

1. Lap bar
2. Rubber boot
3. Anti-slip material
4. Lap bar padding
5. Hand rails
6. Head rests

1. Each vehicle is equipped with an air-operated locking lap bar. Check the operation and locking of every lap bar daily. A detailed description of this procedure is given in the following topic, "Lap Bar Operational Check".

2. Check the condition of the rubber boots between the lap bars and the vehicle fiberglass.
3. Check the operation of the lap bar interlock system using the procedure described in the following topic.
4. Check the overall condition of each vehicle. Inspection points include, but are not limited to, anti-slip material on the seat bottoms and floors, lap bar padding, seat hand rails and head rests.
5. Check the mounting of each vehicle on the spreader bars. The lynch pins must be $7/16$ " diameter. All lynch pins must be in good working order.

1. Sweep
2. Outer spreader bar
3. Inner spreader bar
4. Vehicle
5. $7/8$ " lynch pin
6. Pin
7. Hairpin
8. Headrest

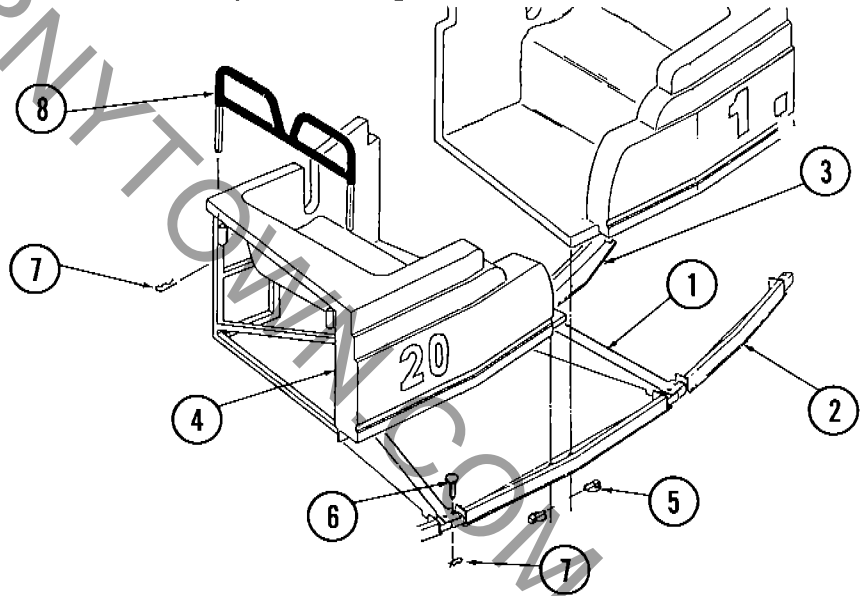

6. Inspect the vehicle frame structures for cracks, bends and other damage.
7. Inspect each vehicle for proper decal installation.
8. Insure that the correct ball studs are used to hold the gas springs in place on the lap bars⁷. The proper ball studs have a step at the base of the ball as shown.

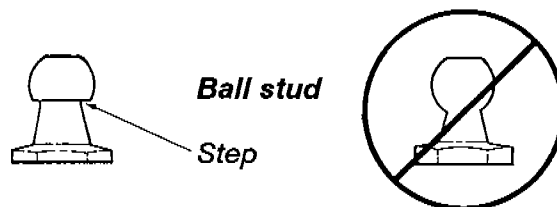

CAUTION
LAP BARS CLOSE AUTOMATICALLY.
KEEP HANDS CLEAR
TO AVOID INJURY

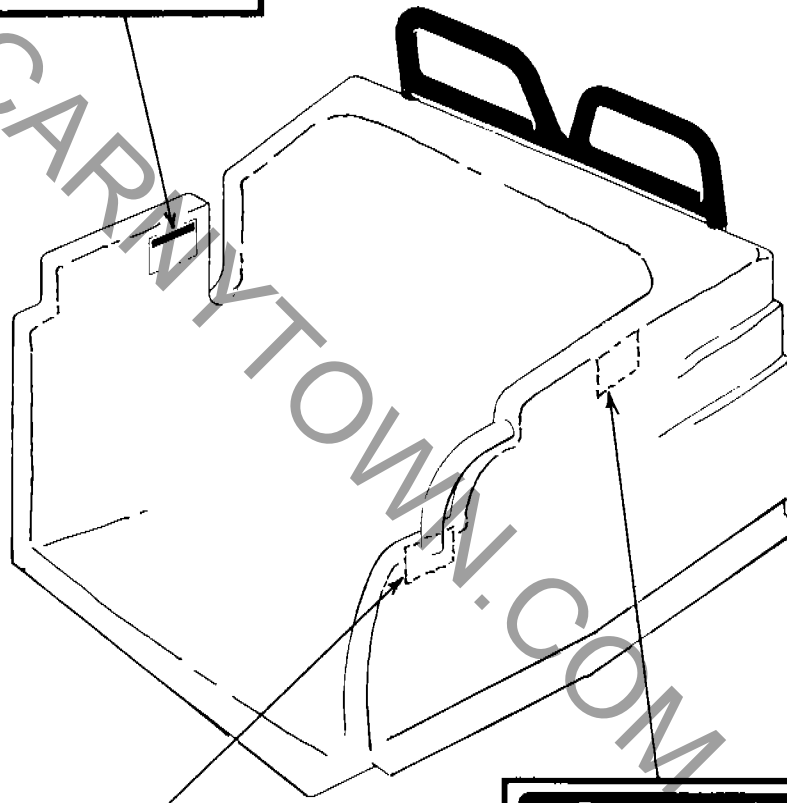

CAUTION
TO AVOID INJURY,
SIT FACING FORWARD WITH
FEET ON FLOOR
KEEP HANDS AND FEET INSIDE
VEHICLE WHEN RIDE IS IN
MOTION

CAUTION
LARGER PERSONS
SIT IN
OUTSIDE SEAT
↓

Lap bar operational check

A lap bar interlock system prevents the ride from being started if any lap bar is not down and locked. Check the interlock system and the operation of every lap bar daily.



WARNING: Checking the lap bar interlock system requires two people. Extreme care must be taken during the procedure, in the event that the ride starts with the lap bar unlocked. Serious personal injury can result.

1. Move the lap bar switch to "Close" to lower the lap bars. Manually lower and lock each lap bar. All green indicator lights on the sweeps must go off.
2. Depress the operator presence switch and start the ride. It should start and run normally.
3. Stop the ride and move the lap bar switch to "Open" to release the lap bars. The lap bars can then be manually raised.
4. Have a helper sit in vehicle number 1 and hold the lap bar just high enough that it will not lock.



WARNING: The helper must be prepared to immediately push the lap bar down into its locked position, in the event the ride starts. To avoid serious personal injury.

5. Move the lap bar switch to "Close" lowering and locking all lap bar except the one being tested. The green indicator light should stay "On" on the lap bar being tested.
6. Depress the operator presence switch and push the rim jog button. The "Ready" light MUST NOT come on and the ride MUST NOT START OR RUN when the lap bar is not down and locked.



WARNING: When testing the lap bar interlock system, use only the RIM JOG button. If the ride starts with the lap bar up, STOP THE RIDE IMMEDIATELY to avoid serious injury to the passenger.

7. If the ride starts, adjustment or repair of the lap bar interlock system is necessary. DO NOT OPERATE THE RIDE UNTIL REPAIRS ARE MADE.

If the ride does not start, the lap bar interlock for that vehicle is working properly. Lower and lock the lap bar after the helper exits the vehicle.

8. Proceed to the next vehicle and repeat Steps 4, 5, 6 and 7 until all the lap bars have been tested, one at a time.
9. Check the operation of the lap bar emergency release lever, located on sweep #1. With all lap bars down and locked, pull this lever to release air pressure to unlock all lap bars.

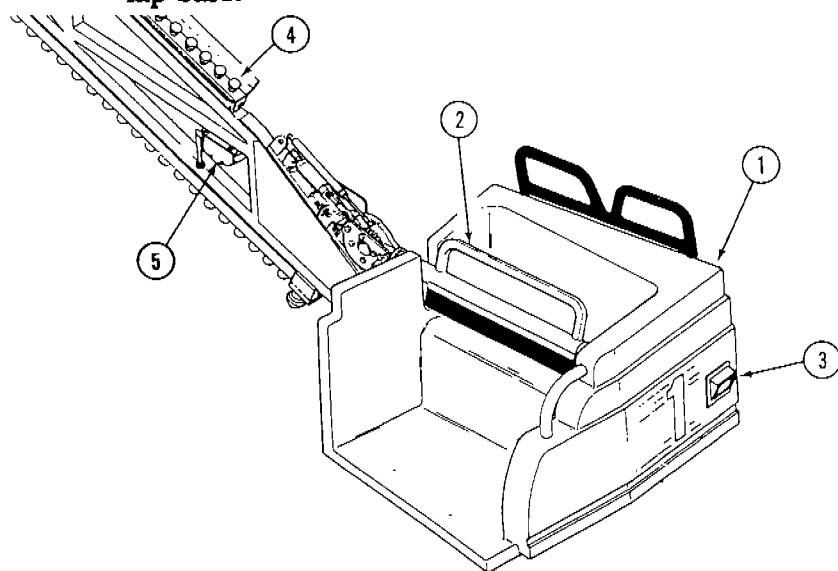

1. Vehicle
2. Lap bar
3. Lap bar switch (vehicle number 1 only)
4. Green indicator light
5. Lap bar emergency release lever (sweep number 1 only)

Sweep inspection

1. Check the installation of all spreader bars, pins and hairpins.
2. Inspect the installation of two sets of cross rods between the sweeps and hub. The cross rods must be in tension, with the turnbuckles snug.

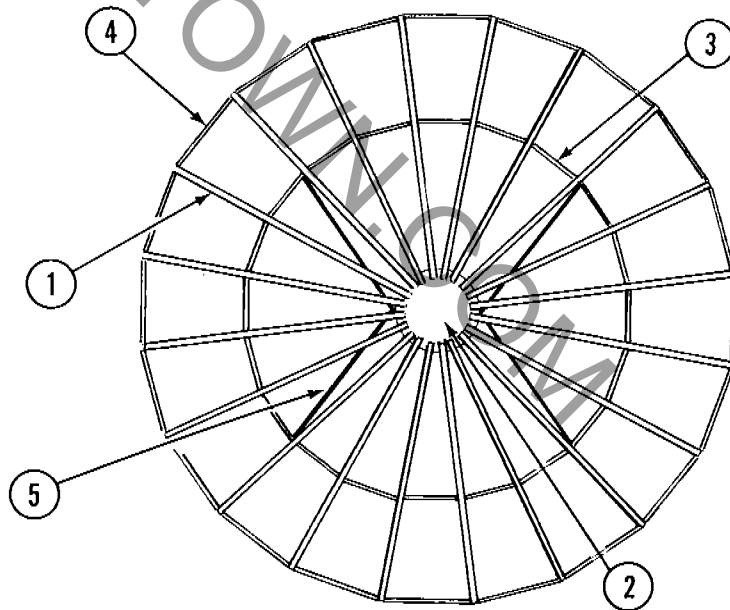

1. Sweep
2. Hub
3. Inner spreader bar
4. Outer spreader bar
5. Cross rod

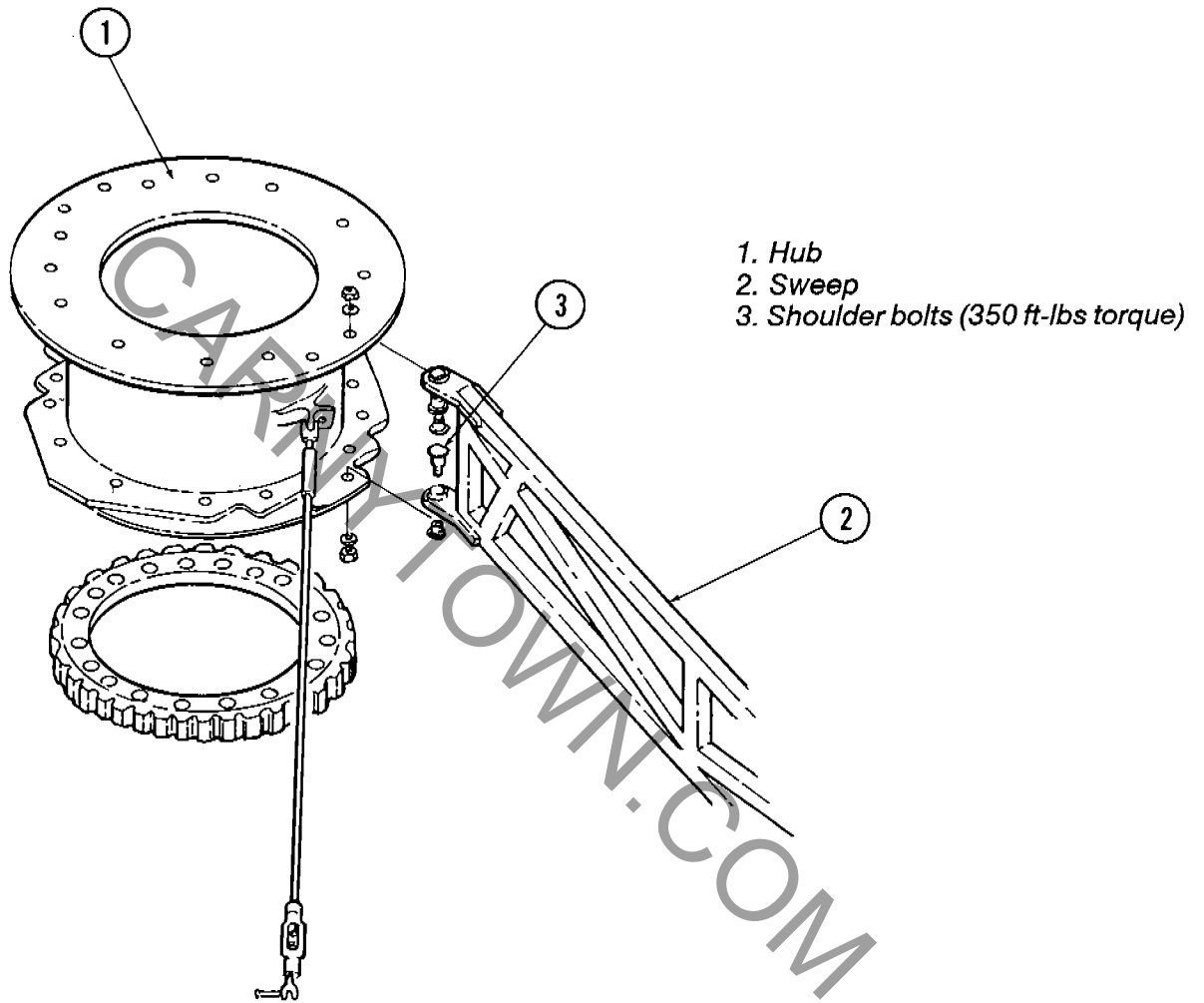

3. Inspect all sweeps for cracks, bends and other damage.
4. Check the shoulder bolts which attach the sweeps to the hub. These are special heat-treated fasteners, tightened to 350 ft-lbs. torque.

Boom and turret inspection

1. Check the boom pivot pins for installation of the retaining bolts.
2. Check the operation of the emergency boom release valve, located under the ride platform on the turret. Carefully open the valve to lower the boom. Check for installation of the safety decal for this valve.

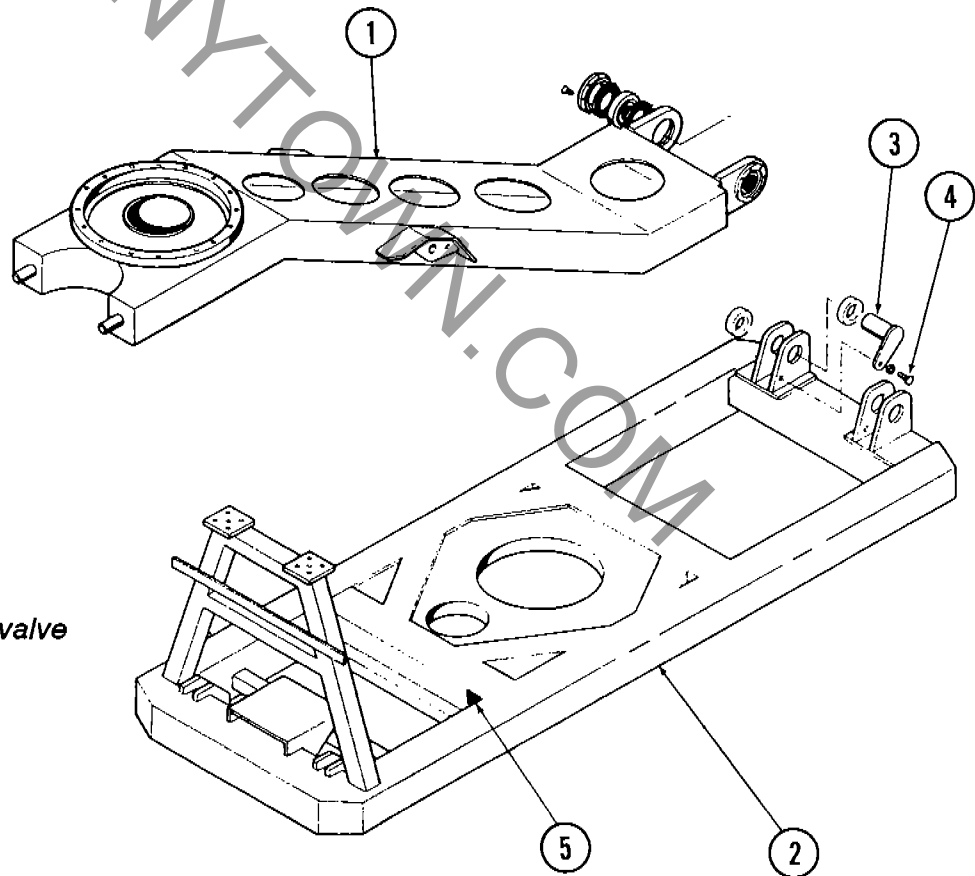

1. Boom
2. Turret
3. Boom pivot
4. Pivot pin retaining bolt
5. Emergency boom release valve

3. Inspect the boom and turret structures for visible cracks or damage.

Electrical and lighting inspection

1. Check the boom limit switch, located on the boom support stand. This switch locks out the lap bar switch, so that the lap bars cannot be unlocked when boom is raised. The switch must be adjusted properly, and **MUST NOT BE BY-PASSED**⁶.

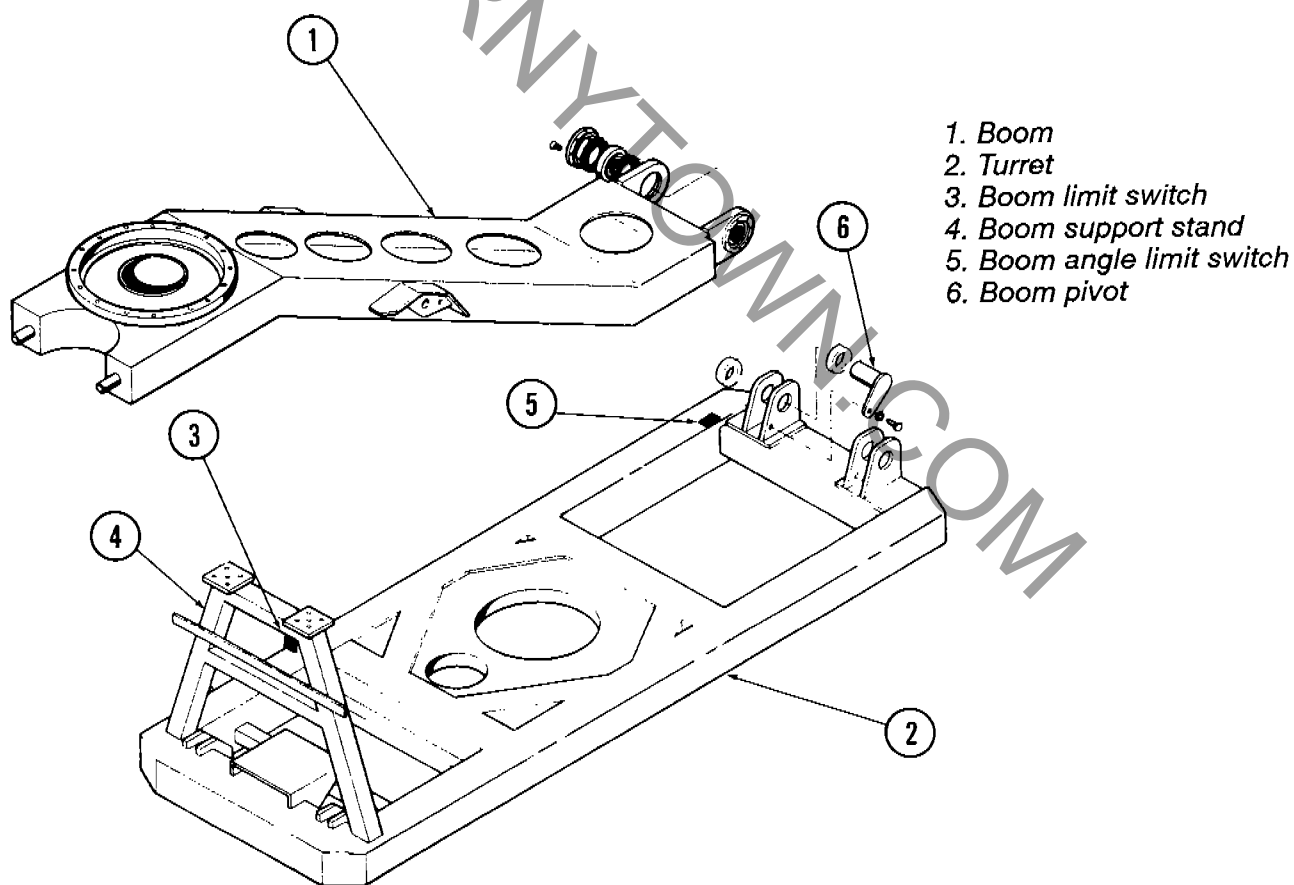

1. Boom
2. Turret
3. Boom limit switch
4. Boom support stand
5. Boom angle limit switch
6. Boom pivot

2. Check the boom angle limit switch, located at the boom pivot. This switch controls the maximum angle of the boom, and must be properly adjusted (3" from the full stroke of the cylinders).

3. Check cable leads, electrical connections and grounding per local code.
4. Test the operator controls, including emergency stop switch, operator presence switch and power switch.
5. Check the electrical jumpers at the front sign and backdrop.
6. Check for installation of safety decals on all electrical boxes.

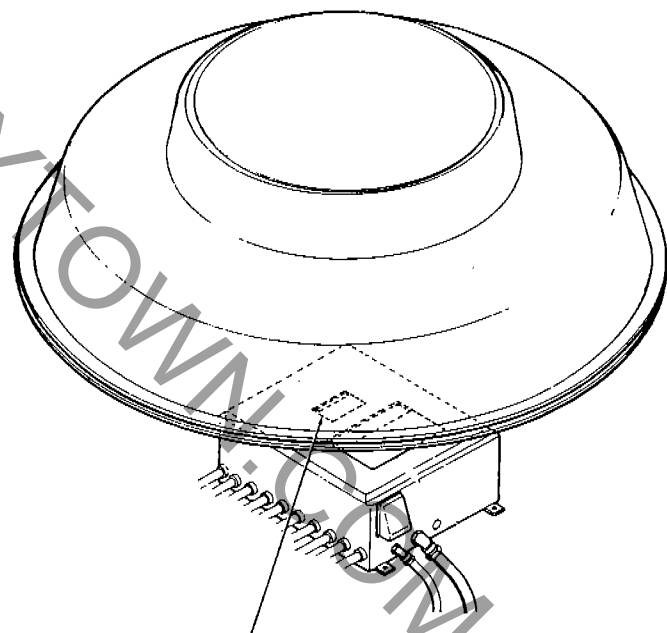

CAUTION
TURN POWER OFF
BEFORE OPENING
BOX

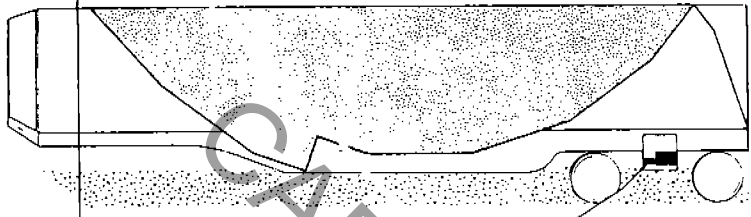

CAUTION
TURN POWER OFF
BEFORE OPENING
BOX

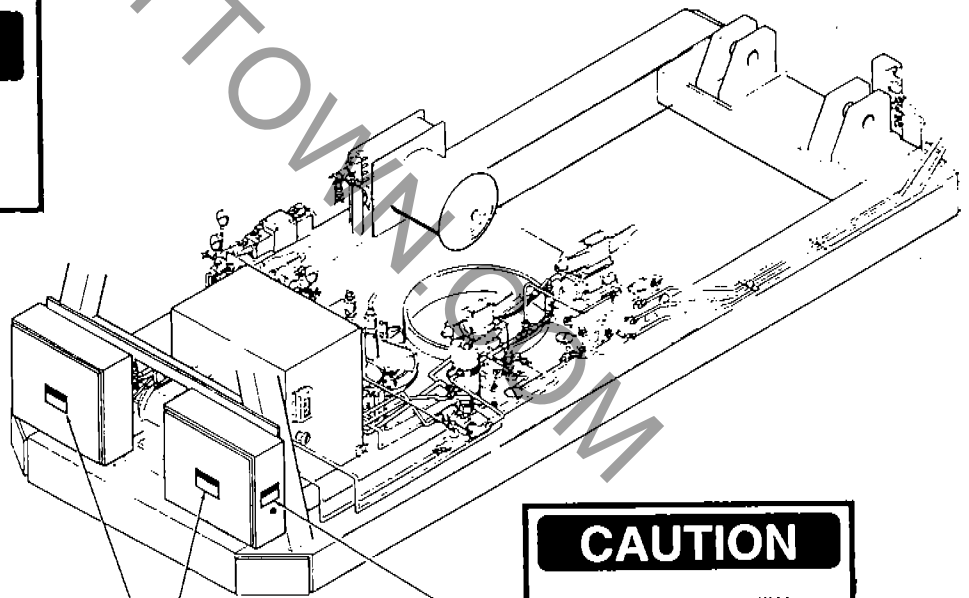

CAUTION
TO PREVENT INJURY
TURRET MUST BE CHAINED
BEFORE ACTIVATING TURRET
BRAKE RELEASE SWITCH

CAUTION
TURN POWER OFF
BEFORE OPENING
BOX

Trailer inspection

1. Check the trailer for installation at proper 5 degree angle.
2. Inspect trailer outriggers for proper installation of pins in inboard hole.

1. Outrigger
2. Pin (set-up position)
3. Pin hole (used for racking only)
4. Pivot pin

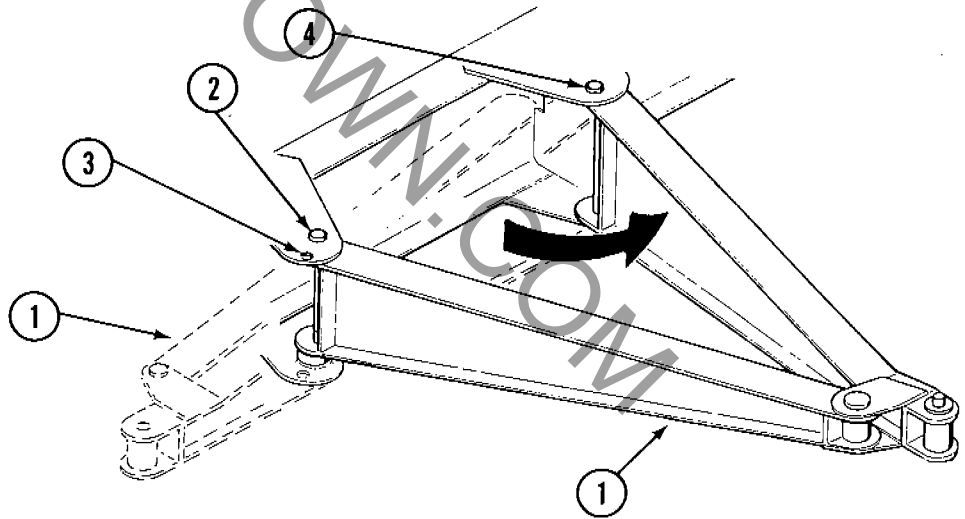

3. Inspect the trailer or park base structures for visible cracks or damage.

Hydraulic system inspection

The WIPEOUT has two separate hydraulic systems, one for trailer leveling and material handling, the other for the drive system.

1. Inspect each hydraulic system, including hoses, tubes, fittings and other components for leaks.
2. Check for installation of safety decal at pressure retard valve.

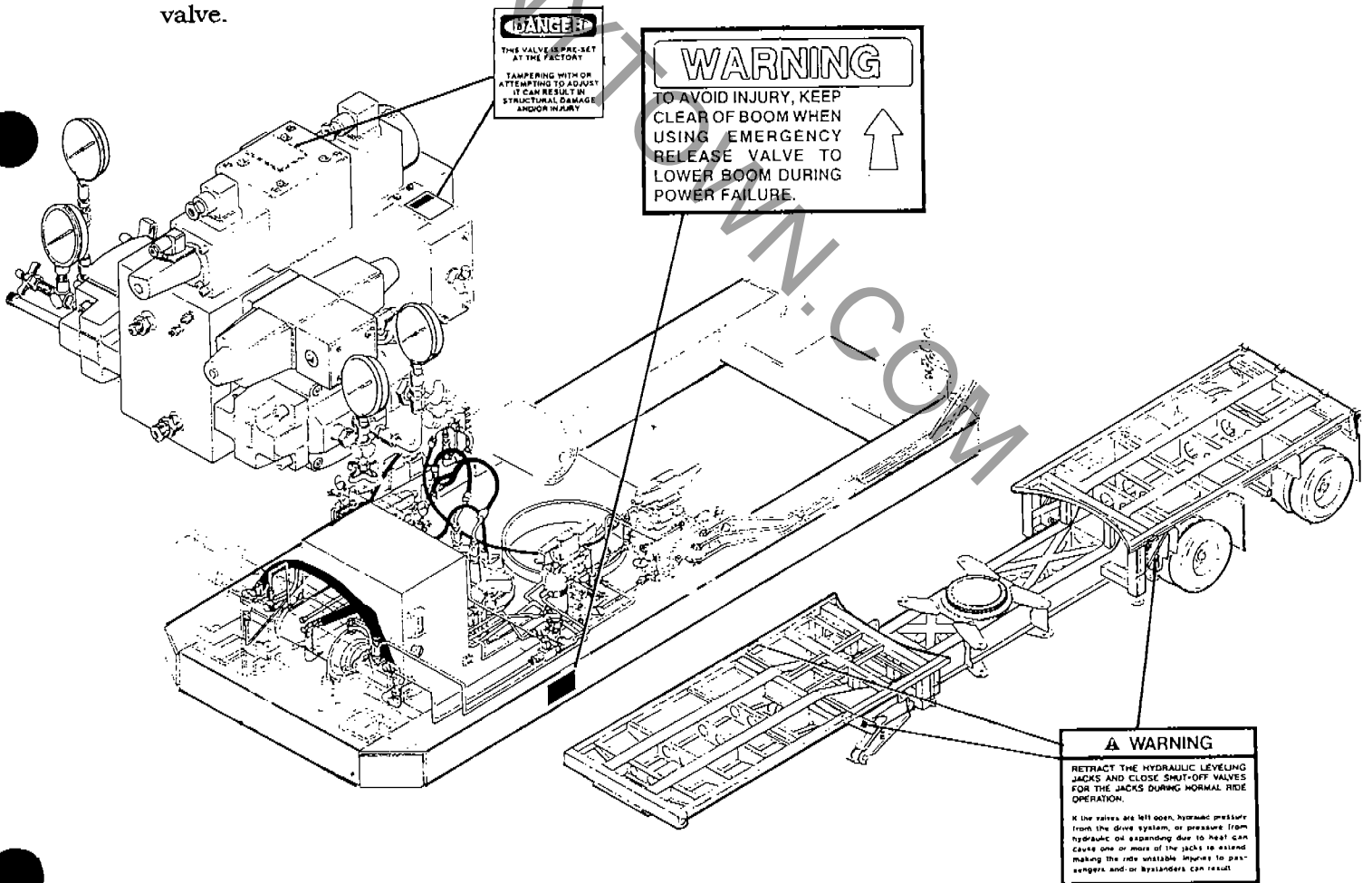

Air system inspection

1. Check for proper air pressure settings. Pressure must be 100 psi at the reservoir and 40 psi at the regulator

1. Air reservoirs
2. Dual regulator
3. Air compressor
4. Air pressure gauge
5. Turret brake
6. Hub brake

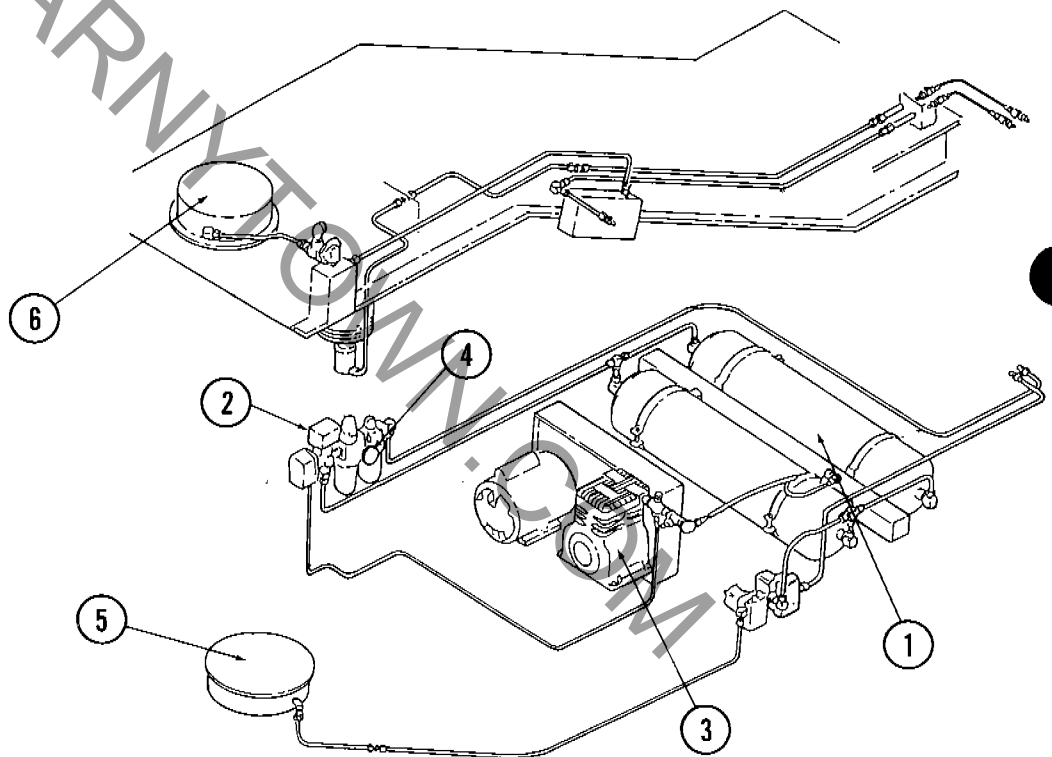

2. Check the entire lap bar air system, including hoses, tubes, fittings and other components for leaks.
3. Check the turret and hub brake air systems, including hoses, tubes, fittings and other components for leaks.
4. Check the operation of the low air pressure indicator light and buzzer.
5. Inspect the vehicle air system for leaks.

Platform and fence inspection

1. Inspect hand rails, ramps, steps and walkways.
2. Inspect all gates and queue line chains. Self-closing gates must operate properly.
3. Inspect all entrance and exit signs.
4. Inspect all safety signs and placards.

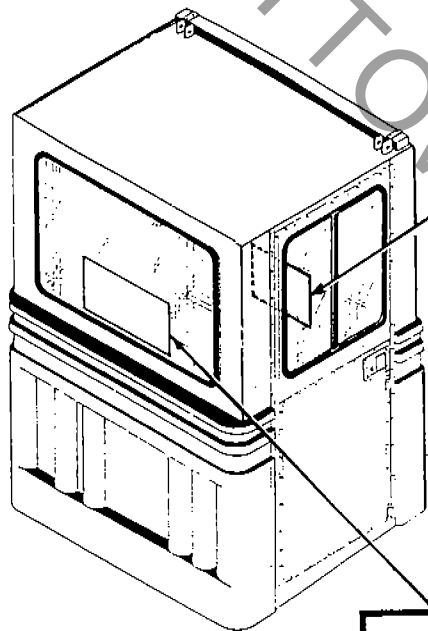

Wipeout Field Inspection

1. Inspect all gates and queue line chains. Self-closing gates must operate properly.

2. Inspect all entrance and exit signs.

3. Inspect all safety signs and placards.

NOTICE TO PASSENGERS

1. NO ONE UNDER 42 INCHES IN HEIGHT SHALL BE PERMITTED TO RIDE.
2. ANYONE WITH BACK OR NECK INJURY MUST NOT RIDE THIS RIDE.
3. ANY PERSON WHO CANNOT BE ADEQUATELY SECURED BECAUSE OF SIZE OR CONDITION WILL NOT BE ALLOWED TO RIDE.
4. PREGNANT WOMEN ARE NOT ALLOWED TO RIDE.
5. PERSONS WHO ARE VISIBLY ILL OR UNDER THE INFLUENCE OF DRUGS OR ALCOHOL ARE NOT PERMITTED TO RIDE.

NOTICE TO PASSENGERS

1. NO ONE UNDER 42 INCHES IN HEIGHT SHALL BE PERMITTED TO RIDE.
2. ANYONE WITH BACK OR NECK INJURY MUST NOT RIDE THIS RIDE.
3. ANY PERSON WHO CANNOT BE ADEQUATELY SECURED BECAUSE OF SIZE OR CONDITION WILL NOT BE ALLOWED TO RIDE.
4. PREGNANT WOMEN ARE NOT ALLOWED TO RIDE.
5. PERSONS WHO ARE VISIBLY ILL OR UNDER THE INFLUENCE OF DRUGS OR ALCOHOL ARE NOT PERMITTED TO RIDE.

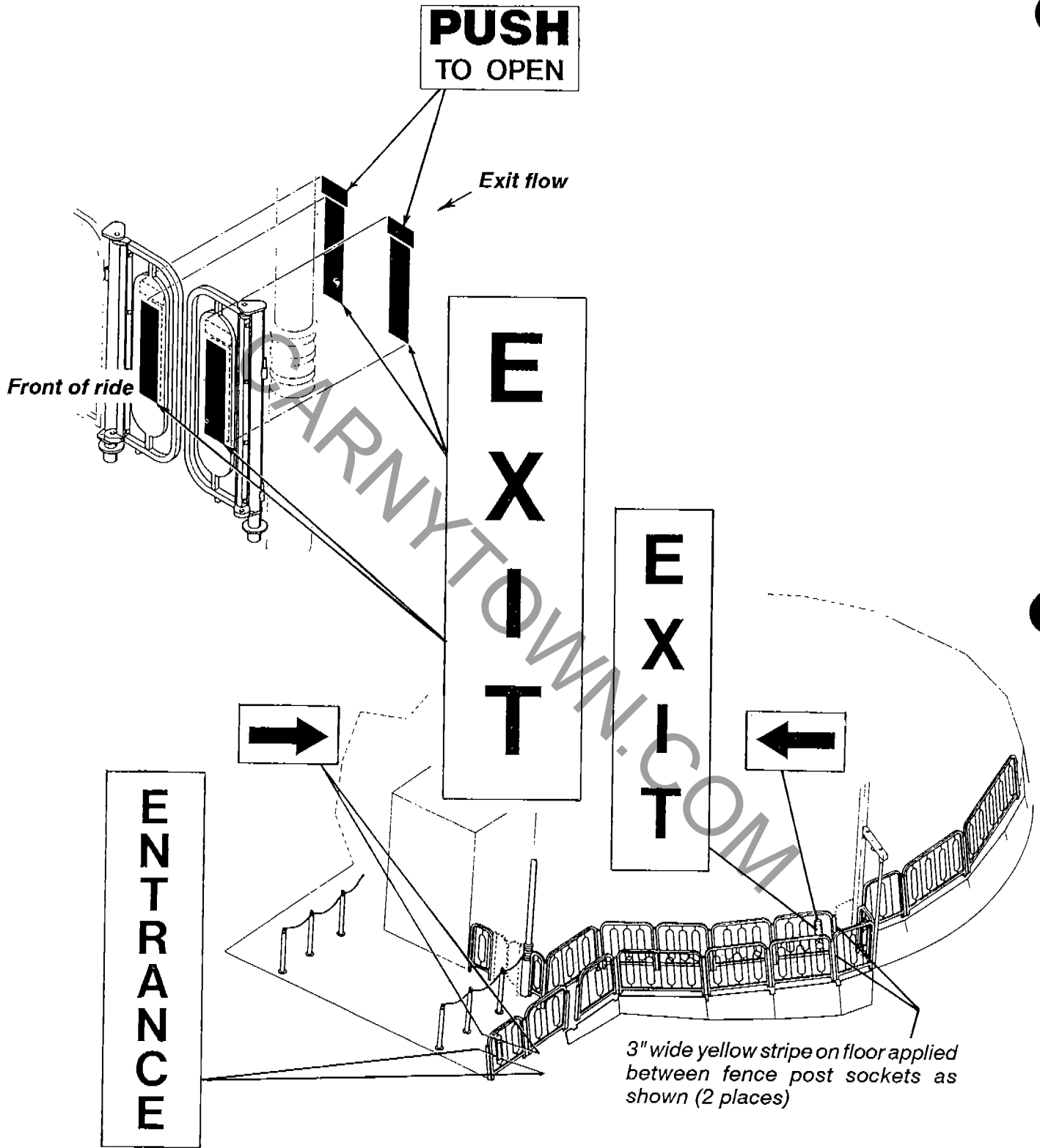

5. Inspect floors and jackstands for proper installation and leveling.

Material handling equipment inspection

1. Inspect the general condition of all chains, cables, winches, straps, etc. Look for broken, worn or missing parts.
2. Inspect the hydraulic cylinders, linkage and rollers for floor racking.
3. Check for proper operation of the winches for the front platform and backdrop sign. The nylon straps must not be cut or frayed.
4. Check for installation of safety decals on floors⁵.

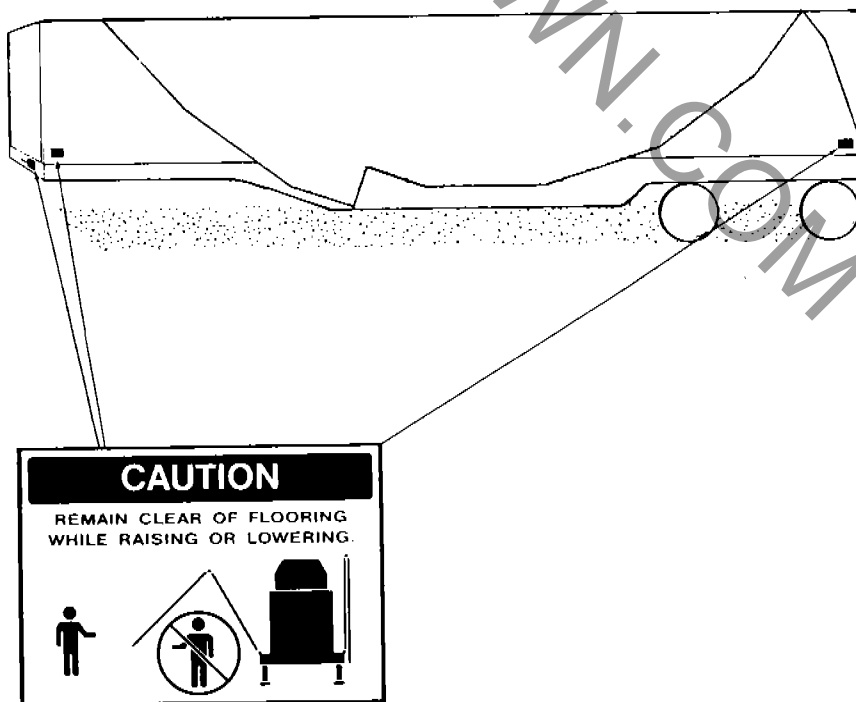

Bibliography

The following service bulletins and manuals are referenced in the preceding text. Service bulletins issued after publication of this guide are located at the back of each section. Any future bulletin releases affecting a ride will be provided by CHANCE RIDES, INC. Bulletins received after receipt of this guide should be considered updates to this guide.

CHANCE RIDES, INC.
4219 Irving
P.O. Box 12328
Wichita, KS 67277-2328

Wipeout Service Manual
24329311

March, 1991 (revised September, 1991)

The *Wipeout Service Manual* includes the Set-up Manual, Operation Manual (#24329312), Maintenance Manual and Parts Catalog

1. *Field Performance Testing Of Amusement Rides*
B090R1002-0
May 14, 1986
2. *Non-destructive Testing*
B090R1022-0
March 21, 1988
3. *General Safety - Tapered Pins*
B090R1056-0
February 9, 1990
4. *Replacement And Torque Requirements For Functional Load Carrying Capscrews*
B090R1075-0
May 25, 1990
5. *Safety Decal*
B090R1085-0
August 17, 1990

6. *Boom Limit Switch*
B402R1102-0
June 14, 1991

7. *Ball Stud Recall*
B402R1104-0
October 11, 1991

CARNYTOWN.COM

CARNYTOWN.COM

CARNYTOWN.COM

CARNYTOWN.COM

CARNYTOWN.COM

CARNYTOWN.COM



NUMBER: A402R1129-0

DATE: JUNE 25, 1993

SUPERSEDES:

America's Largest Manufacturer of Amusement Rides

SAFETY ALERT

Effective Serial Number: 402-00190 through 402-02793

Ride: WIPEOUT

Subject: Boom Pivot Pin Capscrew
Retainer Installation

WARNING: Failure to comply with this Safety Alert Bulletin can result in possible injury to passengers and/or structural damage.

It has been determined by Chance Rides, Inc. that the hex head capscrews used to secure the boom pivot pin in place on the WIPEOUT amusement ride can become loose. If this happens, the pin may start to back out of the boom to turret joint. Damage to the ride and/or injury of passengers and personnel may result.

All owner/operators of the above noted rides are required to order and install the new locking hex head capscrews, part number 26432900 and capscrew retainers, part number 36018200. Two each are required per ride. Parts will be supplied at no charge if ordered within 90 days of the date on this bulletin.

Installation of these parts must be performed by qualified personnel, follow the instructions contained in this bulletin. Personnel must be capable of understanding the function of the parts and their proper installation. If there are any questions regarding installation instructions, contact the Chance Rides, Inc. Customer Service Department.

INSTALLATION INSTRUCTIONS

1. Remove and discard the original capscrews and lock washers.
2. Install retainer and capscrew as illustrated, using 50 to 60 foot pounds with a torque wrench.
3. Bend the two tabs of the retainer down over the edges of the pin.
4. Bend the other tab of the retainer up against the flat side of the capscrew.

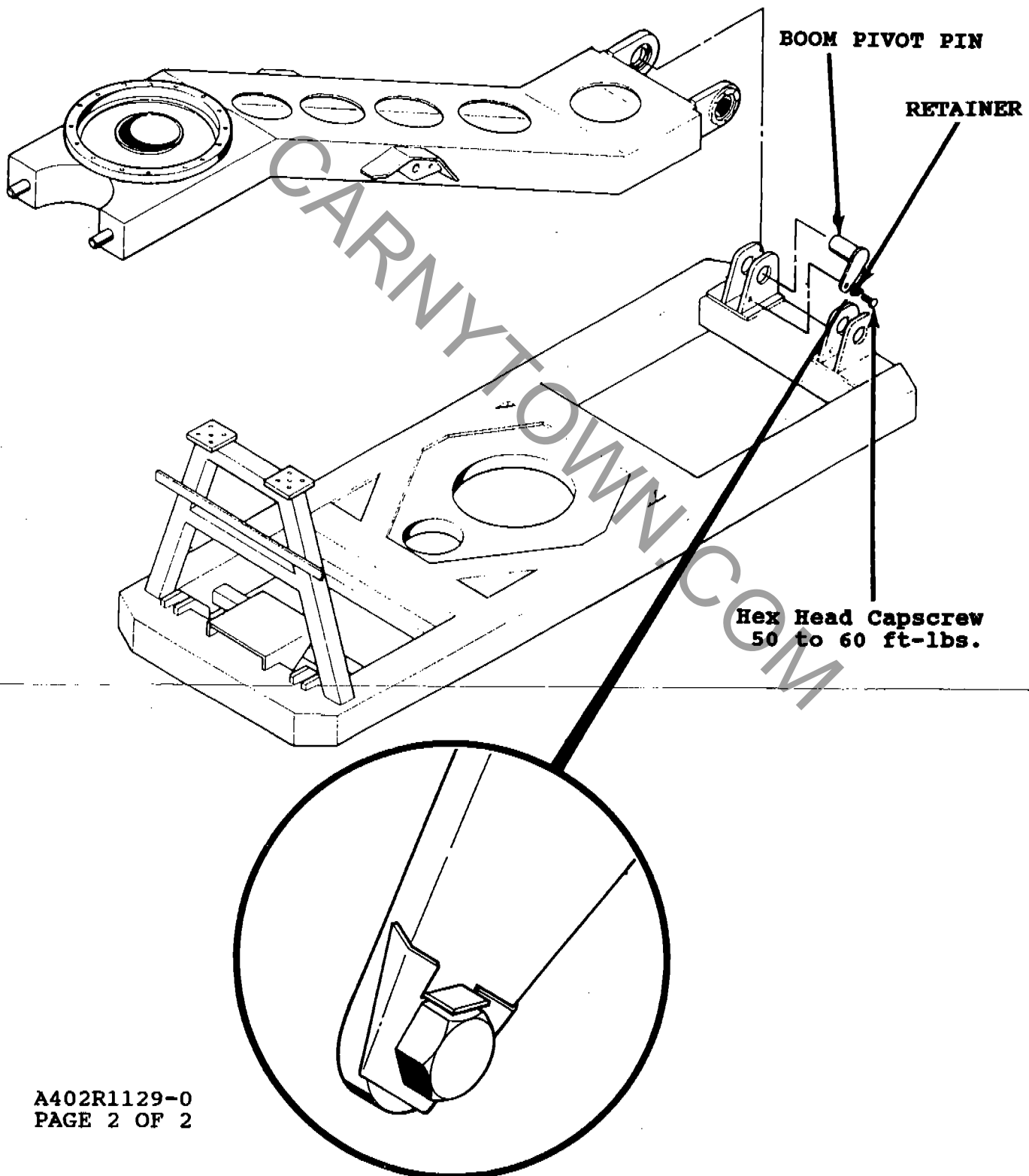



NUMBER: P402R1112-0

DATE: APRIL 10, 1992

SUPERSEDES:

America's Largest Manufacturer of Amusement Rides

PRODUCT IMPROVEMENT NOTICE

Effective Serial Number: 40200190 - 40200290 and 40200491 - 40201991

Ride: WIPEOUT

Subject: Strobe Light Rework

Chance Rides, Inc. has improved the design of the strobe lights on the WIPEOUT amusement ride. These strobe lights are located on the underneath side of each sweep. Owners of the above noted rides can replace the original style strobe lights by ordering and installing kit number K402R1112-0. Each kit contains all parts and instructions necessary to rework one ride. Kits will be supplied at no charge, if ordered within 90 days of the date on this Product Improvement Notice.

All work must be performed by qualified personnel, capable of understanding the function of the parts and their proper installation.

NOTICE

Use only those components authorized, specified or provided by Chance Rides, Inc.

Chance Rides, Inc. SPECIFICALLY DISCLAIMS ANY LIABILITY for losses associated with any unauthorized alterations and/or modifications or additions and installations of unauthorized components.

Contact the Chance Rides Customer Service Department regarding questions concerning this product improvement notice or the installation of Kit K402R1112-0.

Kit number K402R1112-0 contains the following items:

<u>Part Number</u>	<u>Description</u>	<u>Qty</u>
28093400	Transformer	1
61115200	8-32 x 1/2 Machine Screw	4
64780400	8-32 Lock Nut	4
24082600	Strobe Light with Gasket	20
71110300	Cover	20
10000400	Yellow Twist Cap	41
K402R1112-0	Drawing	1

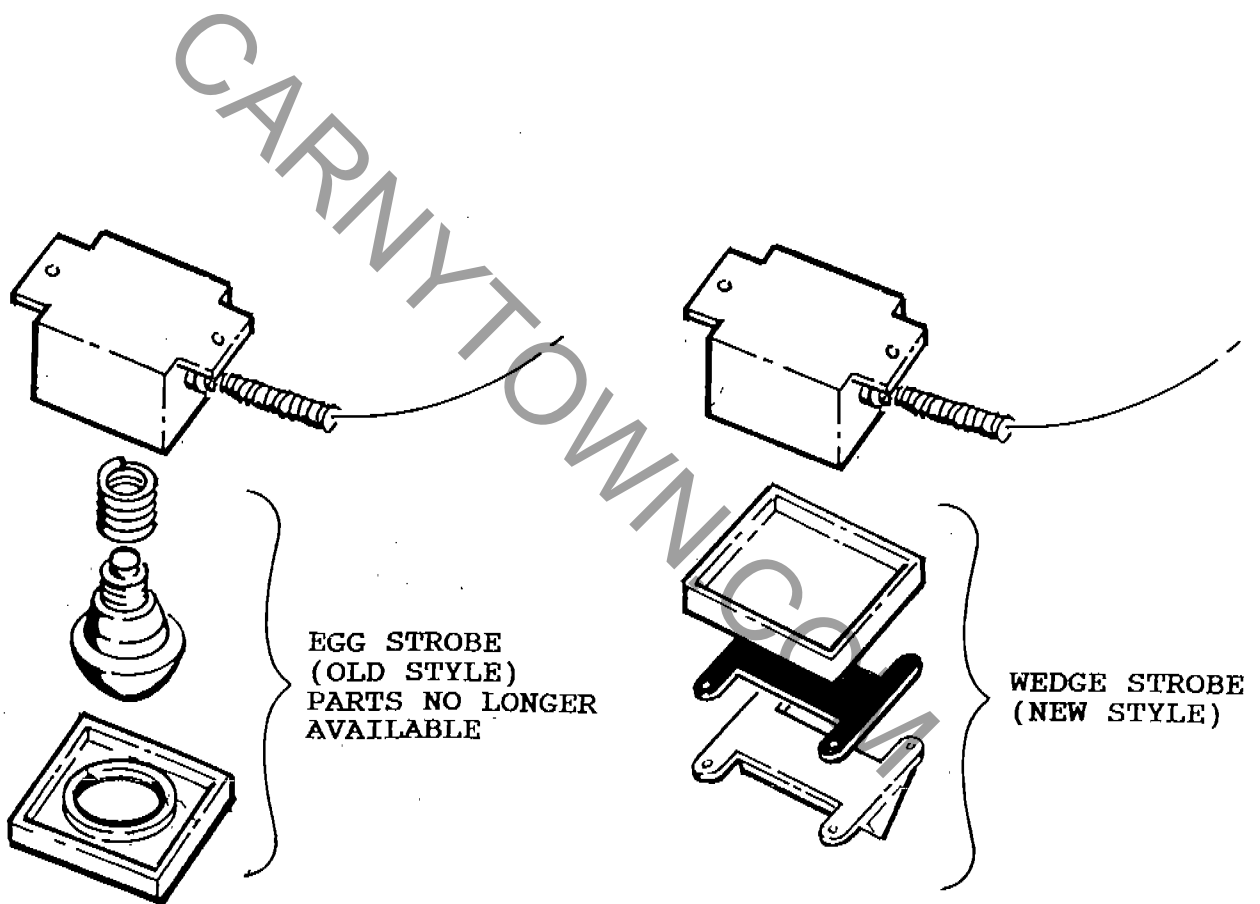



NUMBER: B402R1134-0

DATE: AUG. 6, 1993

SUPERSEDES:

RECEIVED

America's Largest Manufacturer of Amusement Rides

SERVICE BULLETIN

AUG 30 1993

BUREAU OF
FAIR RIDES INSPECTION

Effective Serial Number: 402-00190 through 402-02793

Ride: WIPEOUT

Subject: BRUSH HOLDER
HOUSING LUBRICANT

Chance Rides, Inc. has become aware that it is possible for the brush holder assembly and the collector ring housing on the WIPEOUT amusement ride to seize. If this happens, damage to the equipment can occur. To help prevent the brush holder assembly and the collector ring housing from seizing, Chance Rides, Inc. has developed a special capscrew which when properly installed permits lubrication of this assembly.

All owner/operators of WIPEOUT rides listed above are required to order and install, as outlined in this bulletin the special hex head capscrew, part number 38984500. Two of these special hex head capscrews are required per ride, one for each of the two collector ring housing assemblies. These parts are available at no charge if ordered within 90 days of the date on this bulletin.

Once the special hex head capscrews have been properly installed, lubrication of the housings can be accomplished. Using a number 2 lithium base grease, lubricate housings monthly by applying grease, rotating ride one quarter turn, applying more grease, rotating another one quarter turn and continuing process until housings have been lubricated all the way around.

All work must be performed by qualified personnel, capable of understanding the function of the parts and their proper installation.

NOTICE

Use only those components authorized, specified or provided by Chance Rides, Inc.

Chance Rides, Inc. SPECIFICALLY DISCLAIMS ANY LIABILITY for losses associated with any unauthorized alterations and/or modifications or additions and installations of unauthorized components.

INSTALLATION INSTRUCTION - HEX HEAD CAPSCREWS

PART NUMBER 38984500

1. Turn power off to ride and disconnect the main power supply to the ride.
2. Remove the covers from the brush holder and collector ring assemblies. Retain the original hardware.
3. Remove and discard one of the 3/8 - 16 x 3/4 long hex head capscrews in each of the two brush holder assemblies.
4. Using a number 11 drill bit, drill a hole at the bottom of the hole from which the hex head capscrew was removed in step 3. Drill through the brush holder assembly and the nylon bushing.

NOTE: DO NOT DRILL INTO THE COLLECTOR RING HOUSING

5. Using a torque wrench, install the new hex head capscrews to 19-24 foot pounds.
6. Lubricate as specified in this bulletin.
7. Install the cover over the brush holder and collector ring housing assemblies using the original hardware.

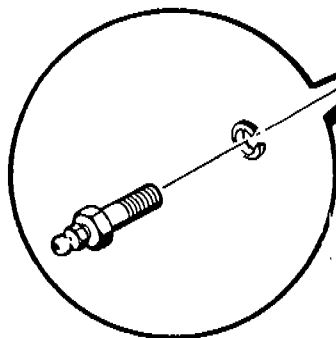
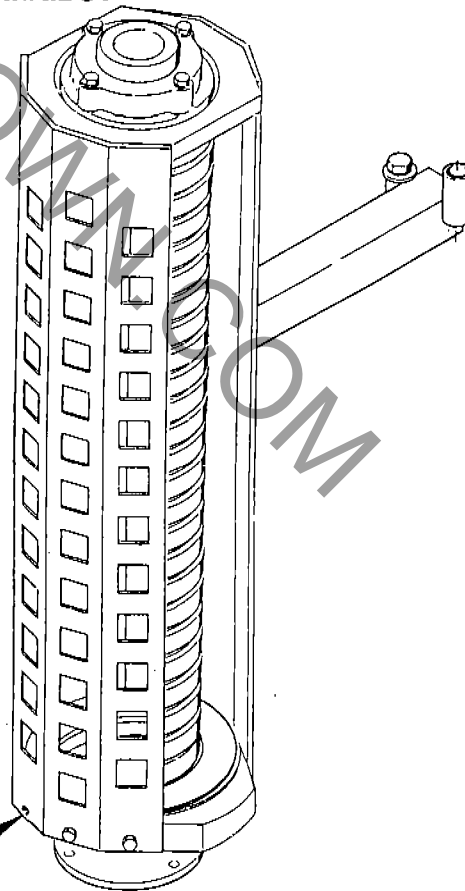
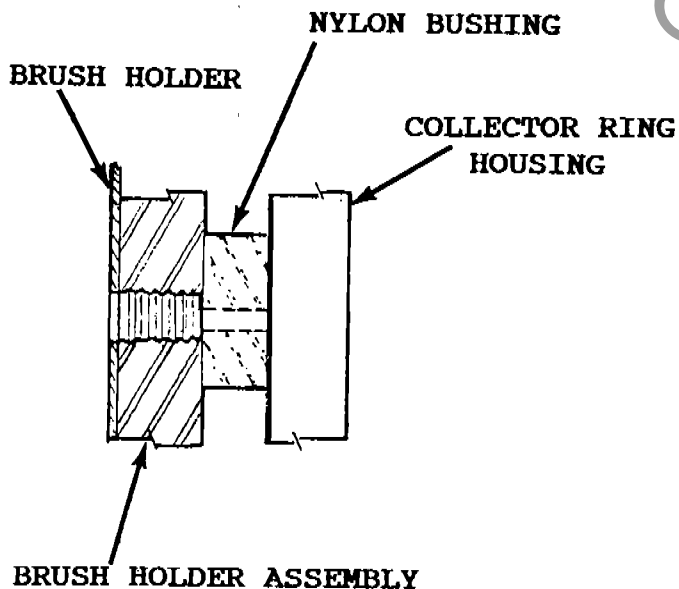

NOTE: LOWER COLLECTOR RING ASSEMBLY SHOWN. UPPER COLLECTOR RING ASSEMBLY OPPOSITE



NUMBER: B402R1164-0

DATE: AUG. 15, 1994

SUPERSEDES:

America's Largest Manufacturer of Amusement Rides

SERVICE BULLETIN

Effective-Serial Number: All-Units

Ride: WIPEOUT

Subject: Turret Drive Inspection

Chance Rides, Inc. has become aware that the socket head cap screws that secure the drive pinion to the bearing keeper for the turret drive of the WIPEOUT amusement ride can loosen. If this occurs, the pinion will become loose and could drop out of position, resulting in damage to mechanical parts.

Chance Rides, Inc. requires all owner/operators of the above noted amusement rides to perform the inspection of the turret drive as outlined in this bulletin.

All work must be performed by qualified personnel, capable of understanding the function of the parts and their proper installation.

NOTICE

Use only those components authorized, specified or provided by Chance Rides, Inc.

Chance Rides, Inc. SPECIFICALLY DISCLAIMS ANY LIABILITY for losses associated with any unauthorized alterations and/or modification or additions and installations of unauthorized components.

INSPECTION PROCEDURES:

1. Raise and block boom to give access to the turret drive motor and to stabilize boom while working under it.

WARNING: Heavy items falling or descending out of control can cause injury to personnel. Make sure the boom is adequately secured before attempting to work under it.

2. Remove the five (5) 5/8-11 x 2 1/2 inch hex head cap screws that hold the hydraulic motor in place.
3. Raise the hydraulic motor to gain access to the bearing keeper.

WARNING: Lifting heavy items can cause injury to personnel. Care must be taken when raising the hydraulic motor, which weighs approximately 150 pounds.

Note: The hydraulic lines may need to be removed from the motor in order to raise the motor out of the way.

4. Check the torque (24 - 30 ft. lbs.) of the six (6) socket head cap screws holding the bearing keeper to the pinion.
5. If any of these socket head cap screws are loose, perform the following procedure:
 - a) remove the socket head cap screws
 - b) clean the threads
 - c) apply Blue Loctite 242 to the threads of the socket head cap screws and reinstall using 22 - 27 ft. lbs. of torque
6. Reinstall the hydraulic motor with the five (5) 5/8-11 x 2 1/2 inch hex head cap screws and 95 to 115 ft. lbs. of torque.

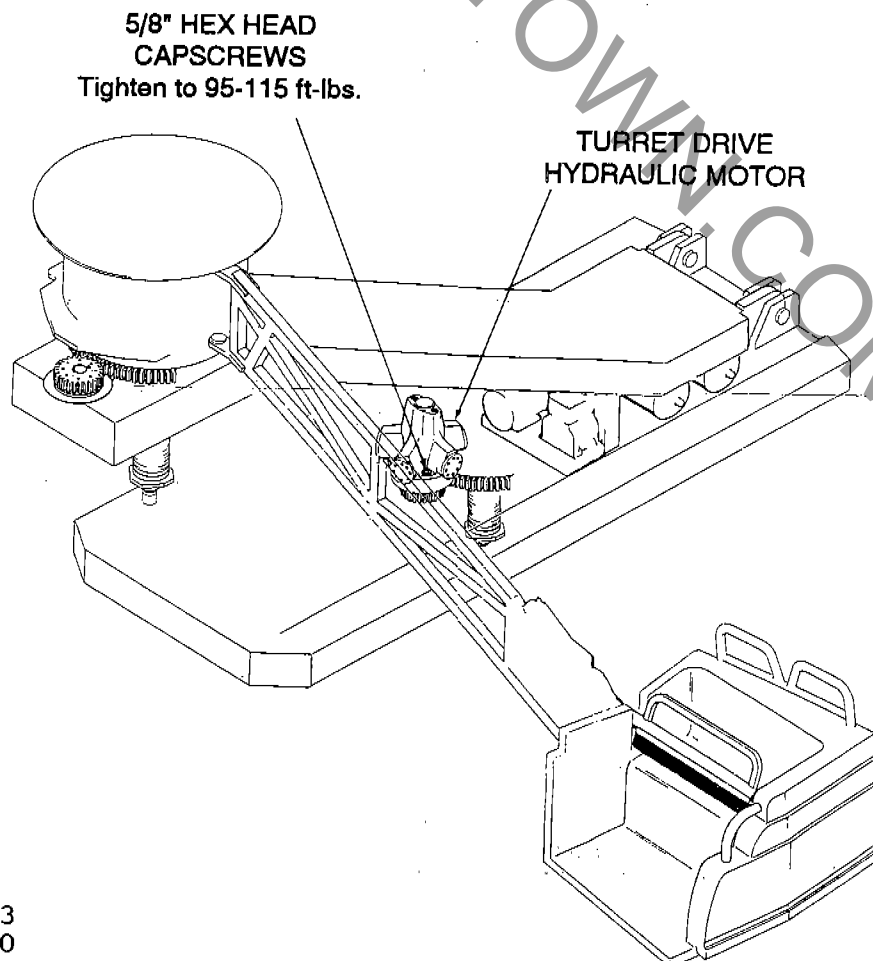

SOCKET HEAD
CAPSCREWS
Apply Loctite® 242 Blue
to threads. Tighten to
22-27 ft-lbs.

BEARING KEEPER

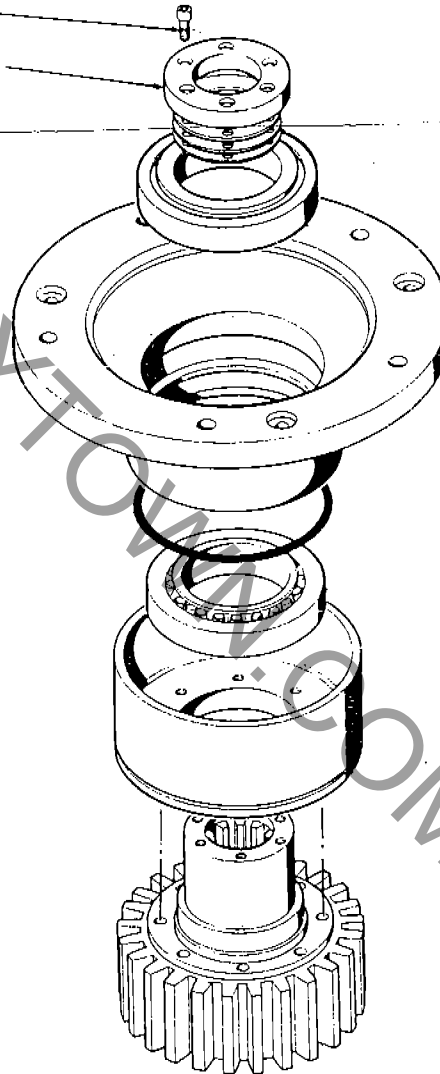

CARNYTOWN.COM



NUMBER: B402R1109-0

DATE: JAN. 17, 1992

SUPERSEDES:

America's Largest Manufacturer of Amusement Rides

SERVICE BULLETIN

Effective Serial Number: All Units

Ride: WIPEOUT

Subject: Hub Capscrew Torque Check

The Center hub section on the WIPEOUT amusement ride is secured to the bearing turntable on the boom by 28, Grade 8 hex-head capscrews. It is essential for the care of the equipment and safety of the passengers to maintain the proper torque on these capscrews. Chance Rides, Inc. requires all owner/operators of the above noted rides to perform the following check at least once per month during the operating season.

1. Verify that the 28 hardened washers under the capscrews securing the center hub section to the bearing turntable on the boom fit flush to the hub.
2. Using a torque wrench, check for proper torque of these 28 capscrews. Torque values for these capscrews should be 110 foot-pounds.

All work must be performed by qualified personnel, capable of understanding the function of the parts and their proper installation.

NOTICE

Use only those components authorized, specified or provided by Chance Rides, Inc.

Chance Rides, Inc. SPECIFICALLY DISCLAIMS ANY LIABILITY for losses associated with any unauthorized alterations and/or modifications or additions and installations of unauthorized components.

CENTER HUB SECTION

BEARING TURNTABLES

90 FOOT-POUNDS TORQUE

FLUSH FIT

HARDENED WASHERS

BOOM

GRADE 8 CAPSCREWS,
1/2 - 13 X 1-1/2 LONG, 28 PLACES

NOTE: If capscrews are removed and reinstalled with lubricated threads 90 foot-pounds must be maintained.



NUMBER: B402R1107-0

DATE: NOV. 22, 1991

SUPERSEDES:

America's Largest Manufacturer of Amusement Rides

SERVICE BULLETIN

Effective Serial Number: 40200190 through 40201691

Ride: WIPEOUT

Subject: Air Filter Kit Rework

Chance Rides, Inc. has become aware that foreign material in the air system may become entrapped in the directional control valves of the brake system on the WIPEOUT amusement ride. If this occurs, damage to the valves may result, making the replacement of the valves necessary. Chance Rides, Inc. has developed a filter kit to help reduce the possibility of this damage occurring.

All owner/operators of the above noted WIPEOUT rides are required to order and install Kit #K402R1107-0. Perform the rework using the instructions provided with this bulletin. Return the attached Certification Of Compliance within fifteen (15) days from receipt of kit.

PARTS LIST

The following parts are included in Kit #K402R1107-0 and are available at no charge if ordered within 90 days from the date of this bulletin.

<u>Item</u>	<u>Part Number</u>	<u>Description</u>	<u>Qty Required</u>
1	62765800	1/4 Close Nipple	1
2	22668400	Filter	1
3	33476573	Hose	1
4	60018800	1/4 to 1/2 Adapter	1

All work must be performed by qualified personnel, capable of understanding the function of the parts and their proper installation.

NOTICE

Use only those components authorized, specified or provided by Chance Rides, Inc.

Chance Rides, Inc. SPECIFICALLY DISCLAIMS ANY LIABILITY for losses associated with any unauthorized alterations and/or modifications or additions and installations of unauthorized components.

KIT INSTALLATION INSTRUCTIONS

1. Locate and remove the 1/2" hard line that connects the air tanks to the directional control valves, as shown in illustration A.
2. Remove the 1/2" to 1/4" adapter from the 1/4" tee, as shown in illustration A.

NOTE: Use a thread sealant before installing new components.

3. Install 1/4" close nipple (Item 1) to the 1/4" tee, as shown in illustration B.
4. Install air filter (Item 2) into close nipple (Item 1) with thread connection pointing upwards.
5. Install 1/4" to 1/2" adapter (Item 4) into end of filter (Item 2).
6. Connect adapter (Item 4) to the air tanks with air hose (Item 3).

NOTE: Check and clean or replace air filter at least once each operating season.

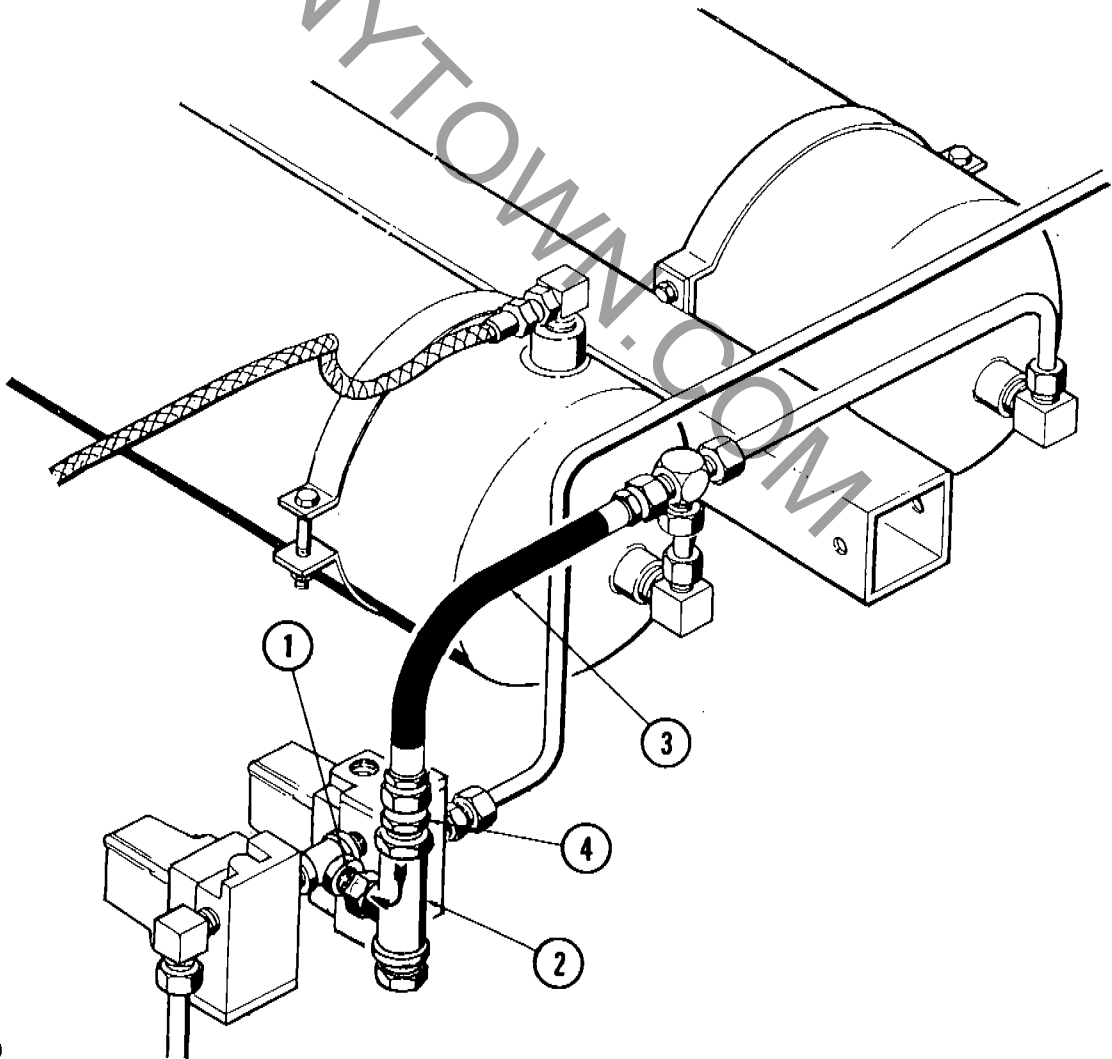



NUMBER: B402R1105-0

DATE: NOV. 25, 1991

SUPERSEDES:

America's Largest Manufacturer of Amusement Rides

SERVICE BULLETIN

Effective Serial Number: All Units

Ride: WIPEOUT

Subject: Floor Handling

Chance Rides, Inc. supplies winches and hydraulic cylinders for raising and lowering the floor sections on the WIPEOUT amusement ride. These safety items must be used in order to prevent possible injury during set-up and tear-down. Decals have also been affixed to the ride at the factory, to warn persons not to stand in the path of the floors as they are being raised or lowered. Check to see that decals are in place before every set up.

The hydraulic cylinders for lowering the side floors are operated by the hand-held control box which installs into the receptacle labeled "floors". The receptacle is located on the curbside electrical box, just forward of the rear jack (see Illustration A).

NOTE: Care must be taken to assure the hand-held box is installed into the proper receptacle at the proper time. The inability to do this may result in damage to the floor cylinder turn buckle assemblies.

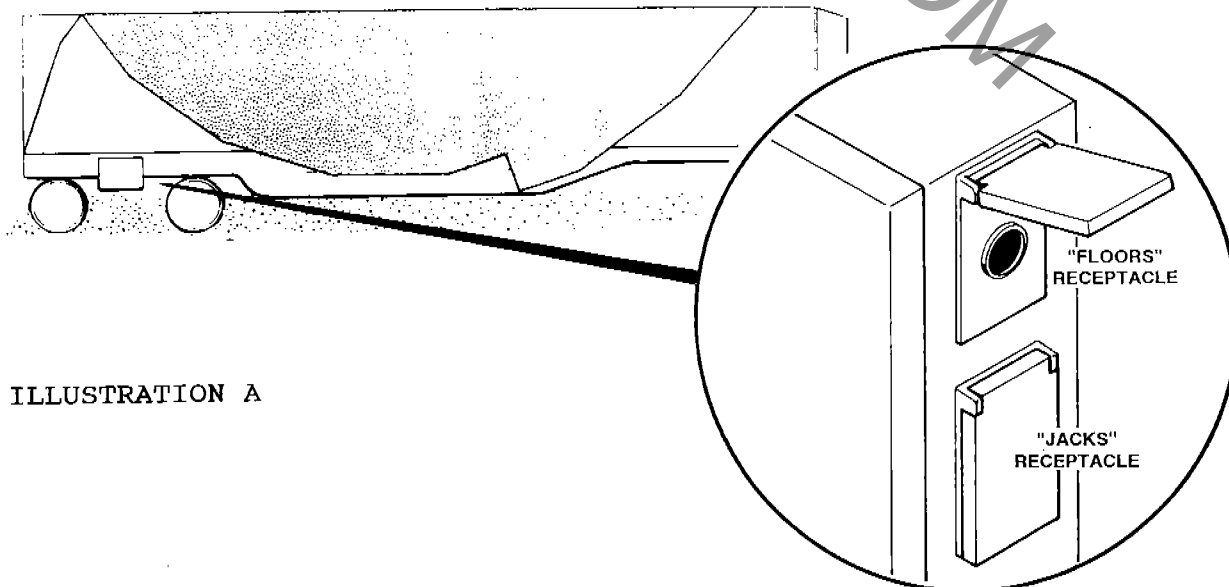

ILLUSTRATION A

Two winches are used to lower the front floor section. These winches are located under floor access panels in front of the operator's control house (see Illustration B). Once the front floor section has been lowered, the winches must be stowed and the access panels reinstalled.

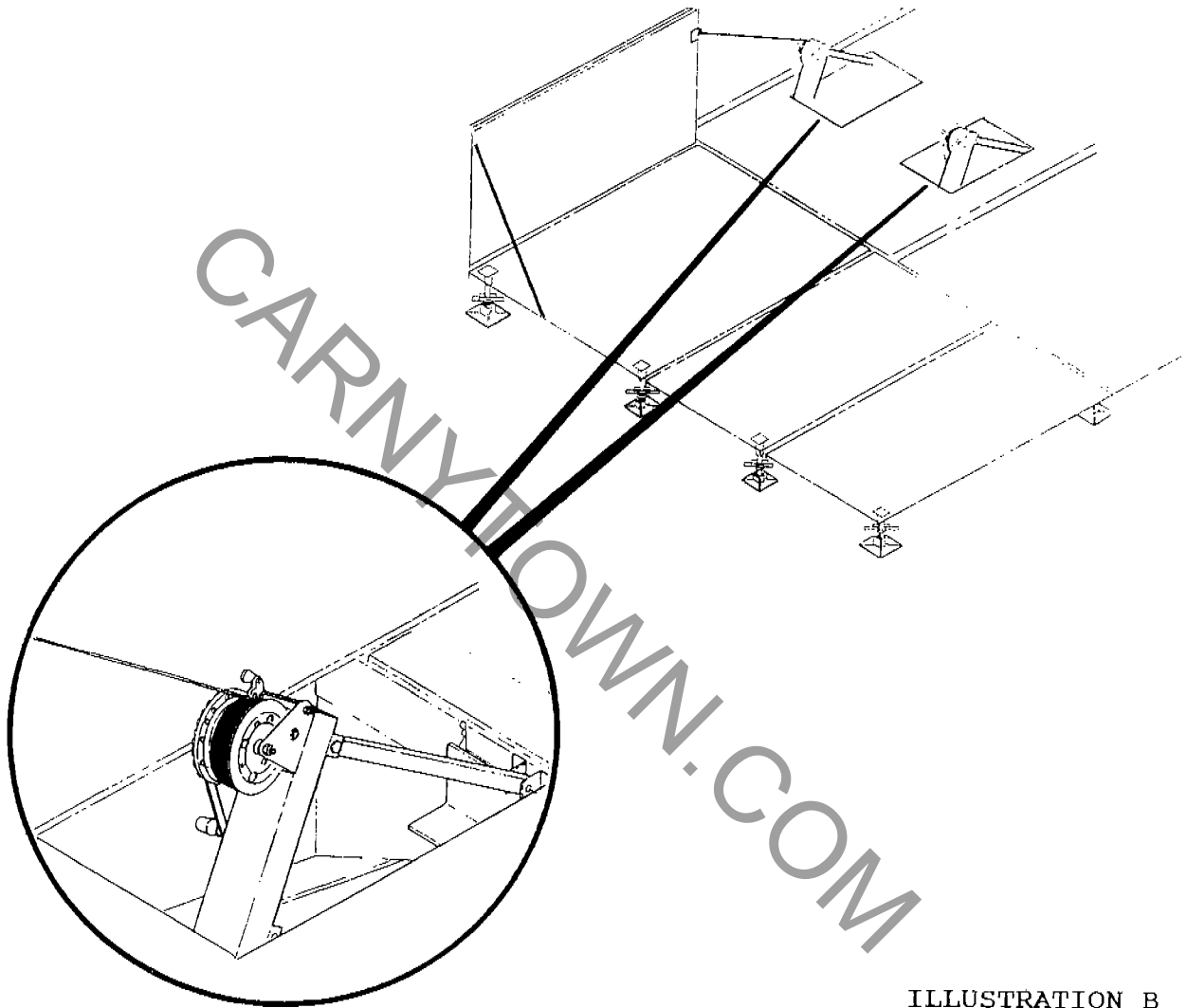
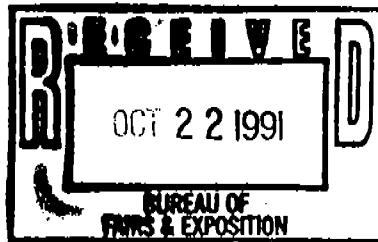

ILLUSTRATION B

WARNING: DO NOT ATTEMPT TO LOWER FLOORS WITHOUT THE USE OF THE WINCHES OR CYLINDERS. FAILURE TO COMPLY WITH THIS BULLETIN COULD RESULT IN INJURY.



NUMBER: B402R1104-0

DATE: OCT. 11, 1991

SUPERSEDES:

America's Largest Manufacturer of Amusement Rides

SERVICE BULLETIN

Effective Serial Number: 40200190 through 40201791

Ride: WIPEOUT

Subject: Ball Stud Recall

Chance Rides, Inc. has become aware that some parts not adequate for their intended use were received and possibly used on some WIPEOUT amusement rides. These parts are the ball studs holding the gas springs in place on the lap bars. If a ball stud breaks the lap bar can fall to the closed position, causing possible injury to passengers.

All owner/operators of WIPEOUT rides identified above are required to comply with this service bulletin.

Install the 40 ball studs, 2 per lap bar, part number 27536300 as shown in this bulletin. To receive credit for ball studs shipped with this bulletin return the completed Certification Of Compliance and the old ball studs within fifteen (15) days from receipt of bulletin.

All work must be performed by qualified personnel, capable of understanding the function of the parts and their proper installation.

NOTICE

Use only those components authorized, specified or provided by Chance Rides, Inc.

Chance Rides, Inc. SPECIFICALLY DISCLAIMS ANY LIABILITY for losses associated with any unauthorized alterations and/or modifications or additions and installations of unauthorized components.

Ball Stud Replacement Procedures:

1. Access lap bar locking mechanism by removing countertop panel.
2. Remove retainer clip from each end of gas spring.
3. Remove the gas spring from the ball studs.
4. Unscrew one ball stud from the lap bar gear assembly and one from the lap bar mount assembly.
5. Using the new ball studs, reverse the above procedure.

LAP BAR MOUNT ASSEMBLY

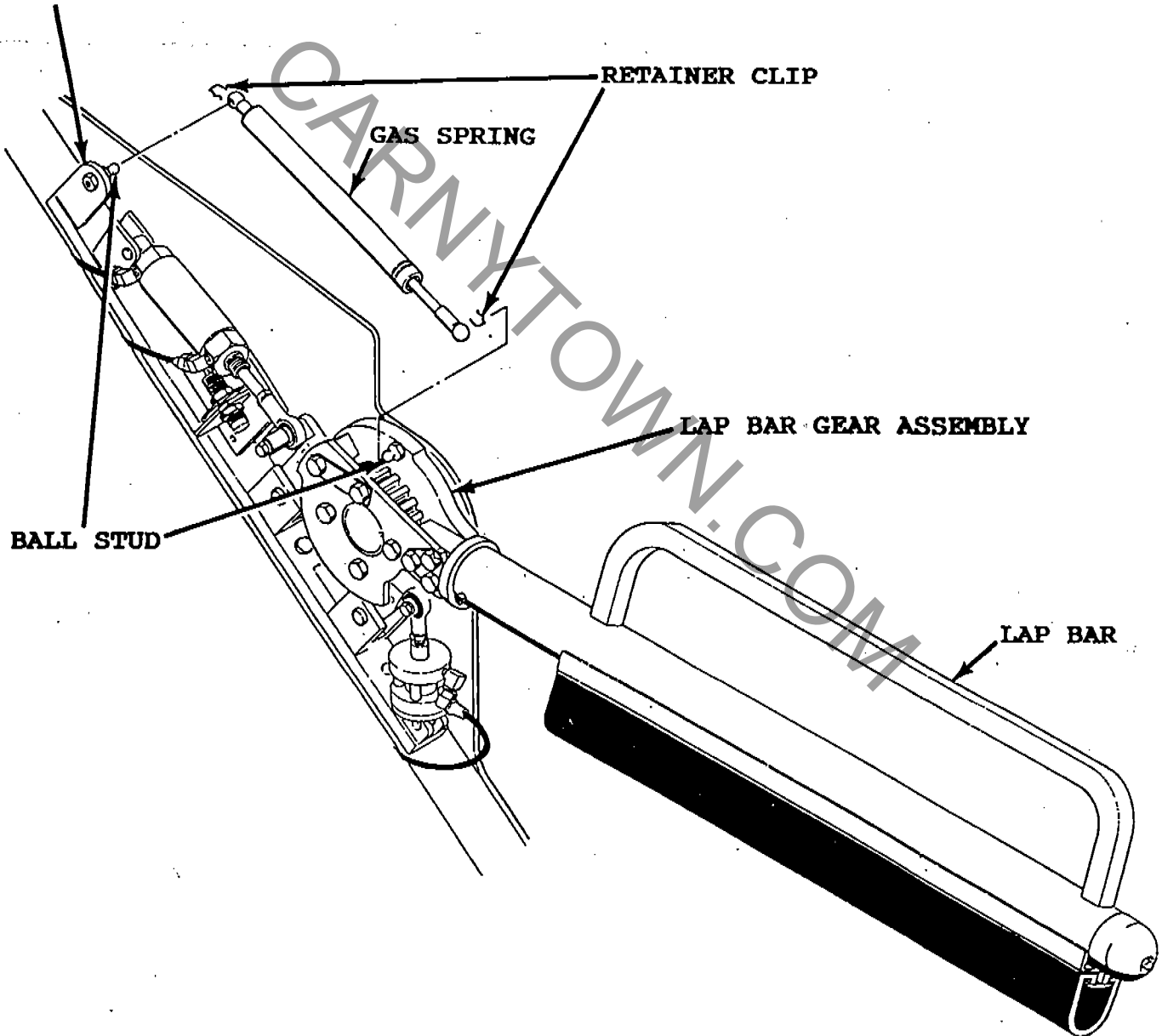



NUMBER: B402R1102-0

DATE: JUNE 14, 1991

SUPERSEDES:

America's Largest Manufacturer of Amusement Rides

SERVICE BULLETIN

Effective Serial Number: All Units - Chance Rides, Inc.

Ride: WIPEOUT

Subject: Boom Limit Switch

Chance Rides, Inc. has received reports of at least one WIPEOUT amusement ride which was operated with the boom limit switch being by-passed. This could allow the lap bars to be unlocked during operation of the ride, resulting in possible injury to passengers.

NEVER OPERATE THE RIDE WITH THE BOOM LIMIT SWITCH BY-PASSED OR TIED DOWN.

The boom limit switch is a safety item located on the boom support stand of the turret. This switch locks out the lap bar switch, located on seat number 1, so that the lap bars cannot be unlocked while the ride is up in the air.

All maintenance personnel and operators must be instructed as to the importance of this switch. This switch must be properly adjusted at all times during operation.

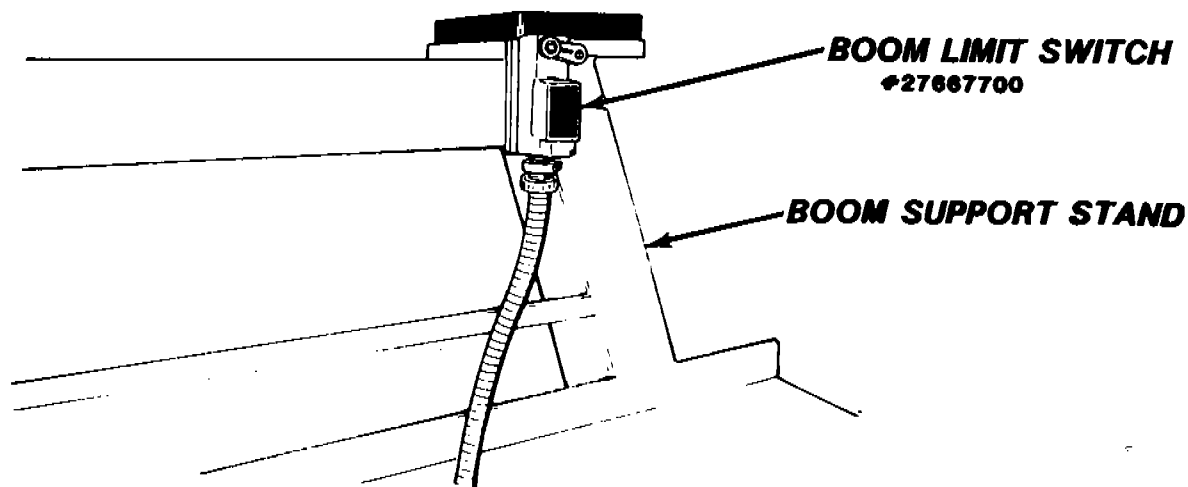



NUMBER: B402R1110-0

DATE: DEC. 20, 1991

SUPERSEDES:

America's Largest Manufacturer of Amusement Rides

SERVICE BULLETIN

Effective Serial Number: 40200190 through 40201891

Ride: WIPEOUT

Subject: Electrical Overload Protector
Inspection/Replacement

Chance Rides, Inc. has become aware that incorrectly sized overload protectors, heaters and fuses, may have been installed on the above noted WIPEOUT amusement rides. The correct size heaters and fuses are necessary to prevent damage to the oil cooler motor, the pump motor for the leveling jacks, and the motor for the air compressor.

Chance Rides, Inc. requires all owner/operators of the above noted rides to perform the inspection and if necessary, the replacement of parts, as outlined in this bulletin.

All work must be performed by qualified personnel, capable of understanding the function of the parts and their proper installation.

NOTICE

Use only those components authorized, specified or provided by Chance Rides, Inc.

Chance Rides, Inc. SPECIFICALLY DISCLAIMS ANY LIABILITY for losses associated with any unauthorized alterations and/or modifications or additions and installations of unauthorized components.

CAUTION: To prevent electrical shock, disconnect all power to the ride before performing any of the following work.

If a new heater or fuse is required, per this bulletin, they will be supplied free of charge, if ordered within 90 days of the date on this bulletin.

INSPECTION/REPLACEMENT OF OIL COOLER MOTOR HEATER & AIR COMPRESSOR FUSE

This heater and fuse are located in the motor control box, the left hand box with the on/off handle, mounted to the turret.

1. Turn power handle to off position and open door.
2. Locate single heater and inspect for correct heater size. Correct size is AR8.5. If any other size heater is present, order and install new heater, part number 23331702.
3. To replace heater, remove the two (2) screws securing the heater in place.
4. Locate fuse in fuse block directly above oil cooler motor heater and inspect for proper size. The fuse may have to be removed to determine size. The correct size is FNQ20. If any other fuse is present, order and install new fuse, part number 22149200.

