

CHANCE S

MANUFACTURING COMPANY INC.

AMERICA'S LARGEST, MOST COMPLETE

MFG: CHANCE RIDES, INC.
NAME: TOBOGGAN
TYPE: NON-KIDDIE

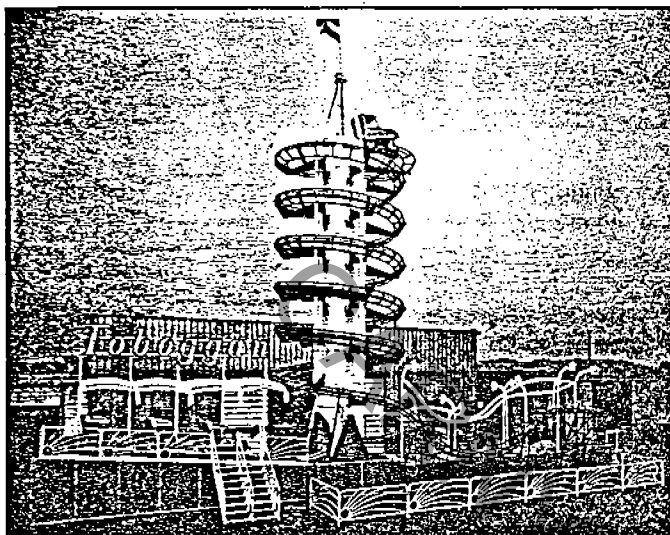

TOBOGGAN

A unique track ride featuring lots of turns as your passengers come spiraling down around the center tube. The 40 ft. ride up through the center of the tube is quite a thrill itself. Especially as the car breaks over the top and starts downward over the more than 450 ft. of track.

Furnished trailer mounted on one 40 foot tandem axle trailer and one 37 foot single axle trailer equipped with 9:00 x 20 tires, air brakes, 12 volt lighting, all according to ICC standards. Erection of ride assisted by hydraulic cylinders. Ride complete with four cars, all electricals including electric motor, 220/440 volt, 3 phase, illuminated sign and exterior lighting.

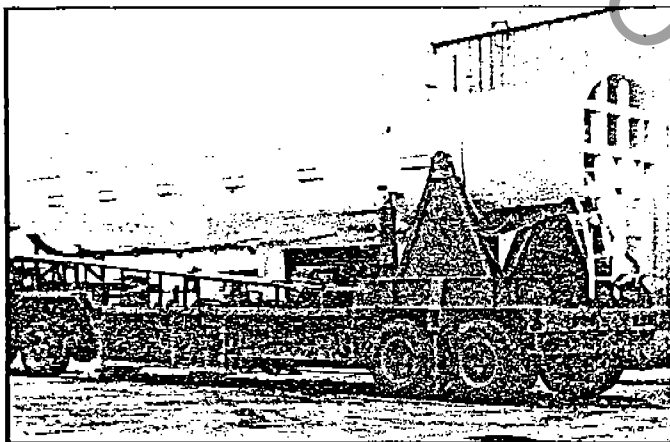

SEATING:	4 cars - 3 adult passengers each
LOADING:	Continuously loading one car at a time
CAPACITY:	Approx. 400 per hour
DRIVE:	Hydraulic (Electrically Driven)
LIGHTING:	Incandescent and Fluorescent
CONSTRUCTION:	All steel with fiberglass panels
TOTAL POWER:	Requires approx. 30 KW
SET UP TIME:	4 men 6 hours



C. P. Huntington Miniature Rail Trains ■ Starliner Trackless Train ■ Old 99 Electric Train ■ Merry-Go-Rounds ■ Helicopter ■ Star Jet ■ Sky Fighter ■ Roller Coaster ■ Kiddie Auto Ride ■ Kiddie Boat Ride ■ Flying Bobs ■ Zipper ■ Twister ■ Rotor ■ Trabant ■ Toboggan ■ Sky Diver ■ Sky Wheel ■ Dodgem Cars ■ Monster Mouse ■ Turbo ■ Yo-Yo ■ Ticket Boxes ■ Stereo Music Systems ■ Parts - Service and Accessories for all listed rides and rides formerly manufactured by Allan Herschell Co. - Since 1880

Factory and General Office: 4219 Irving, Box 2397, Wichita, Kansas 67201 Area Code (316) 942-7411

Sales Office: 1103 Ross Ave., Dallas, Texas 75202 Area Code (214) 742-3802 Cable - Duce Dallas - Telex 73-0300

SPECIFICAT

TOBOGGAN SPECIFICATIONS

**TRAILER:
(Main)**

Width: 8 ft.
 Height: 13 ft. 6 in.
 Length: 38 ft. 8 in.
 Total Weight: Approx. 43,500 Lbs.
 King Pin 16,000 Lbs. Rear Axle 27,500 Lbs.

**TRAILER:
(Auxiliary)**

Width: 7 ft. 4 in.
 Height: 13 ft. 6 in.
 Length: 37 ft.
 Total Weight: Approx. 23,000 Lbs.
 King Pin 8,500 Lbs. Rear Axle 14,500 Lbs.

**OPERATING DIMENSIONS:
(Includes Clearance)**

Ground Width: 78 ft. frontage
 Ground Depth: 25 ft.
 Maximum Height: 55 ft.

Ground Area Required for Toboggan
 (No Clearance Allowances)

Ground to High Point of Ride
 55' Center of Tower

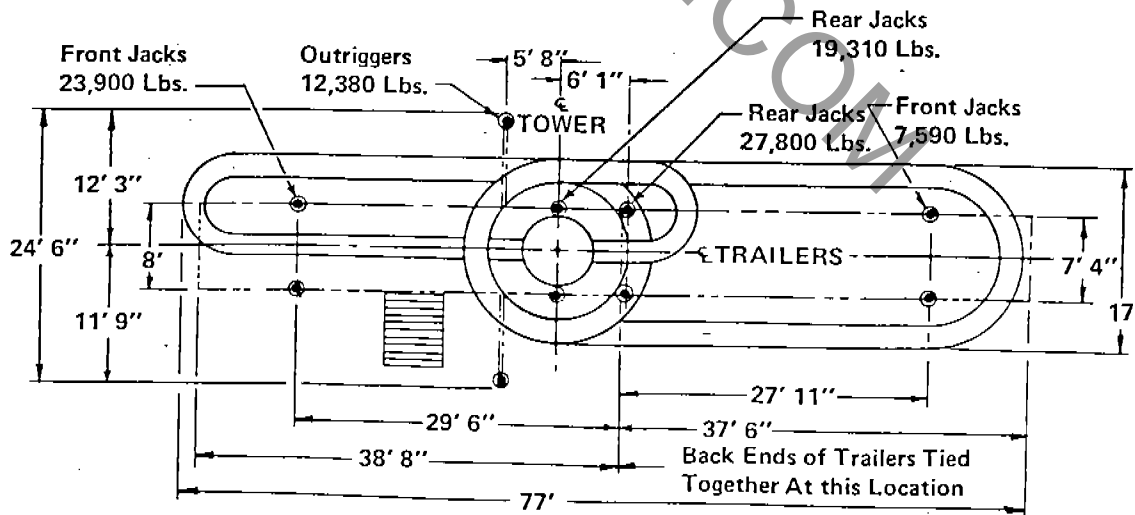

MIDWAY

CARNY TOWN.COM

TOBOGGAN

Ride Serial Number _____ Owner _____ Date _____

FIELD INSPECTION POINTS

1. () Inspect blocking and leveling.
2. () Inspect lock nuts on leveling jacks.
3. () Inspect hydraulic valves for leveling jacks.
4. () Inspect cable leads, electrical connections and grounding per local code.
5. () Inspect all fences and steps for proper assembly.
6. () Inspect condition of track, chain, rollers, wear in guide channel and anti-roll back pins (Bulletin B107R1061-0).
7. () Inspect tower lock-up attachments.
8. () Inspect alignment and attachments of auxiliary trailer.
9. () Inspect all braking systems on track.
10. () Inspect all rollers on cars (Bulletin B107R1061-0).
11. () Inspect brake shoes on cars.
12. () Inspect axle pivot bearing on cars. Inspect threads on axles and castellated nuts.
13. () Inspect deceleration mechanism on cars.
14. () Inspect anti-roll back devices on cars (Bulletin B107R1061-0).
15. () Inspect pick-up dog and dog lock-up mechanism on cars (Bulletin B107R1061-0).
16. () Inspect condition of padding and lap bar in car.
17. () Inspect hinge joint on cars.
18. () Inspect hatch latching mechanism of cars (Bulletin B107R1061-0).
19. () Check rate of descent of cars - Minimum 53 seconds unloaded (Bulletin B107R1061-0).
20. () Inspect hatch shut-off switch (Bulletin B107R1061-0).
21. () Inspect one car entry switches and bell (Bulletin B107R1061-0).
22. () Inspect structure for cracks, bad welds, etc.
23. () Inspect electrical circuit for shorts, bad wires, etc.
24. () Inspect for hydraulic leaks.
25. () Inspect overall appearance of ride for cleanliness and general overall upkeep.

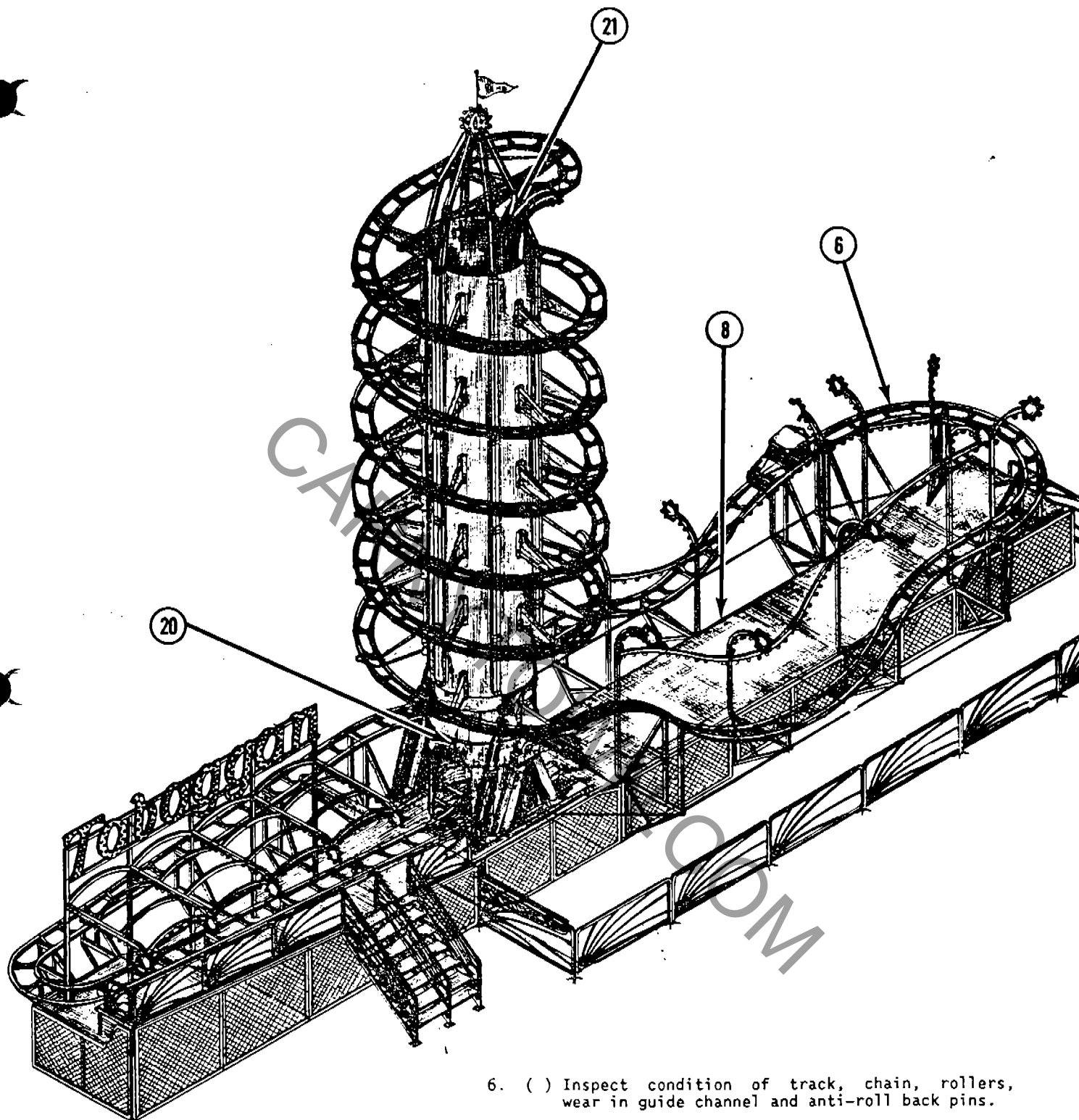

- 6. () Inspect condition of track, chain, rollers, wear in guide channel and anti-roll back pins.
- 8. () Inspect alignment and attachments of auxiliary trailer.
- 19. () Check rate of descent of cars - Minimum 53 seconds unloaded (Bulletin B107R1061-0).
- 20. () Inspect hatch shut-off switch (Bulletin B107R1061-0).
- 21. () Inspect one car entry switches and bell (Bulletin B107R1061-0).

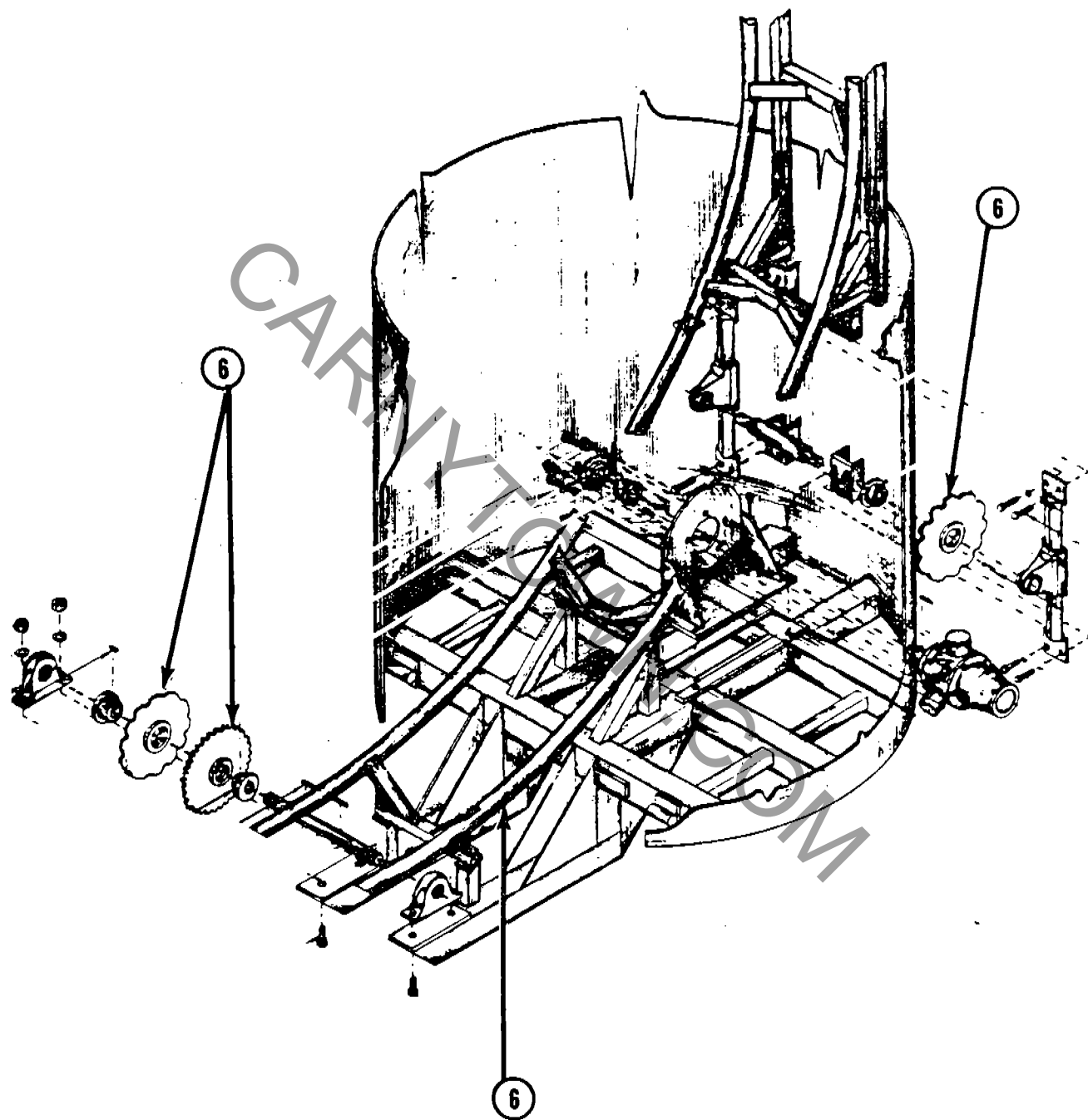

6. () Inspect condition of track, chain, rollers, wear in guide channel and anti-roll back pins (Bulletin B107R1061-0).

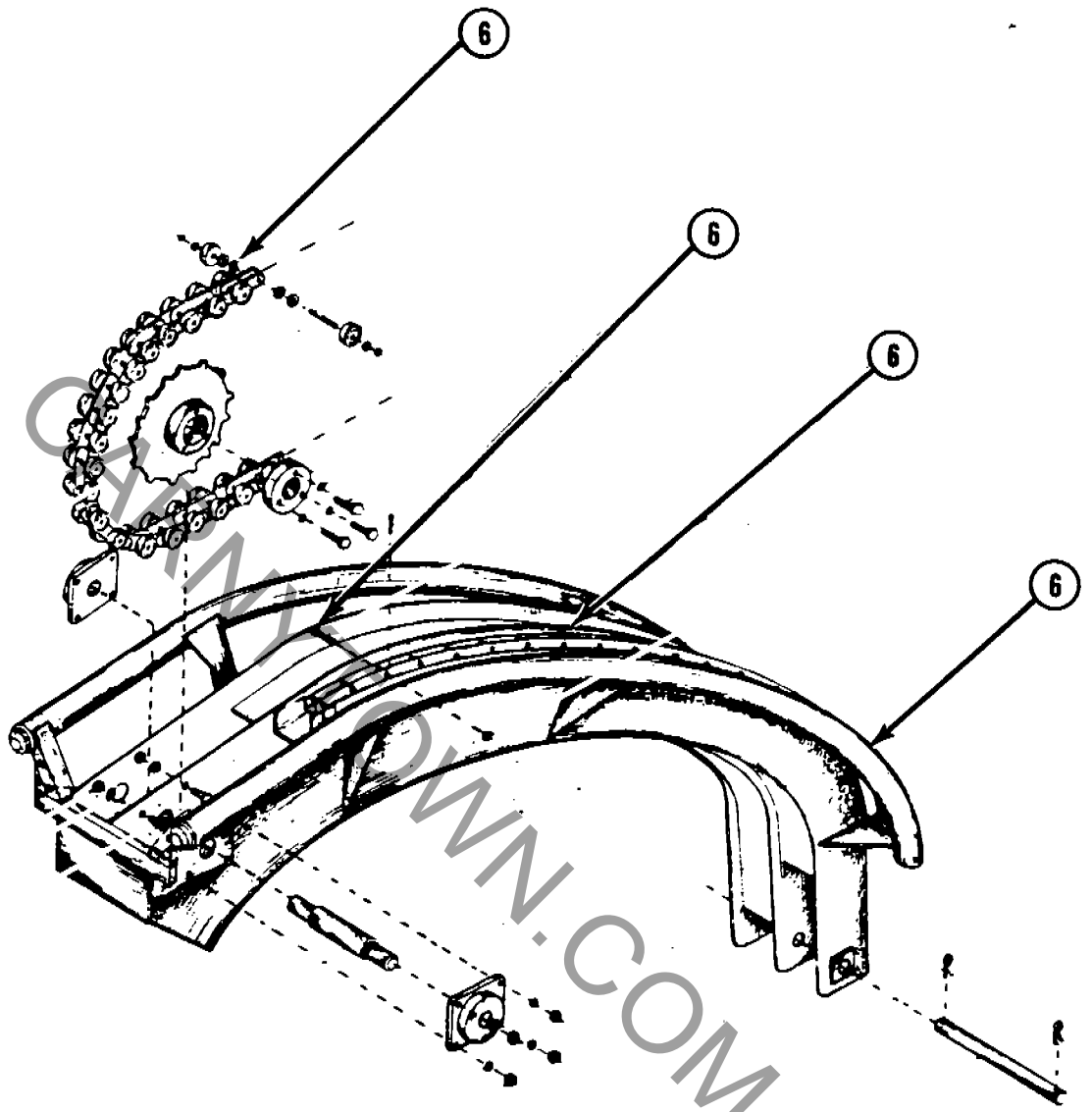

6. () Inspect condition of track, chain, rollers, wear in guide channel and anti-roll back pins (Bulletin B107R1061-0).

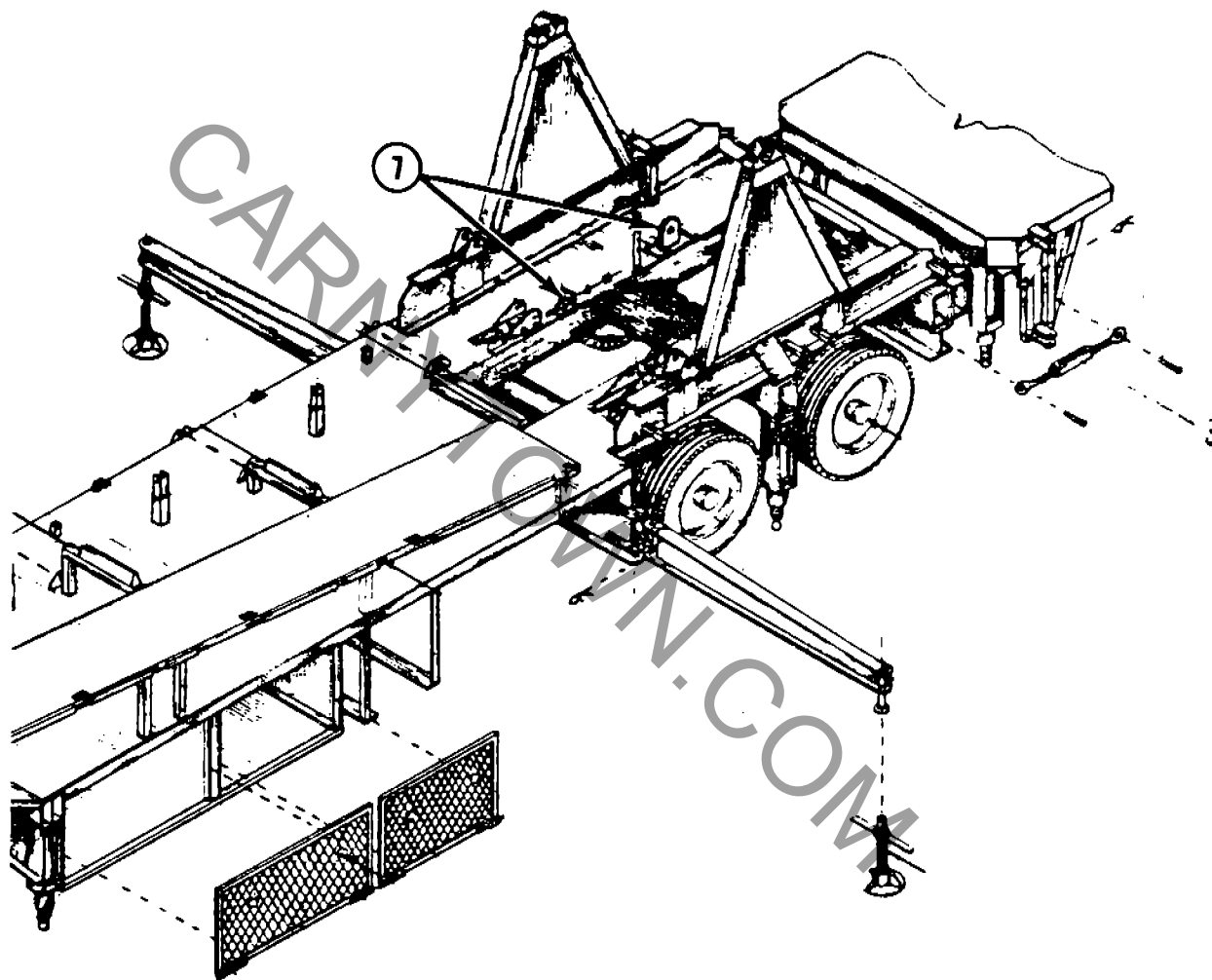

7. () Inspect tower lock-up attachments.

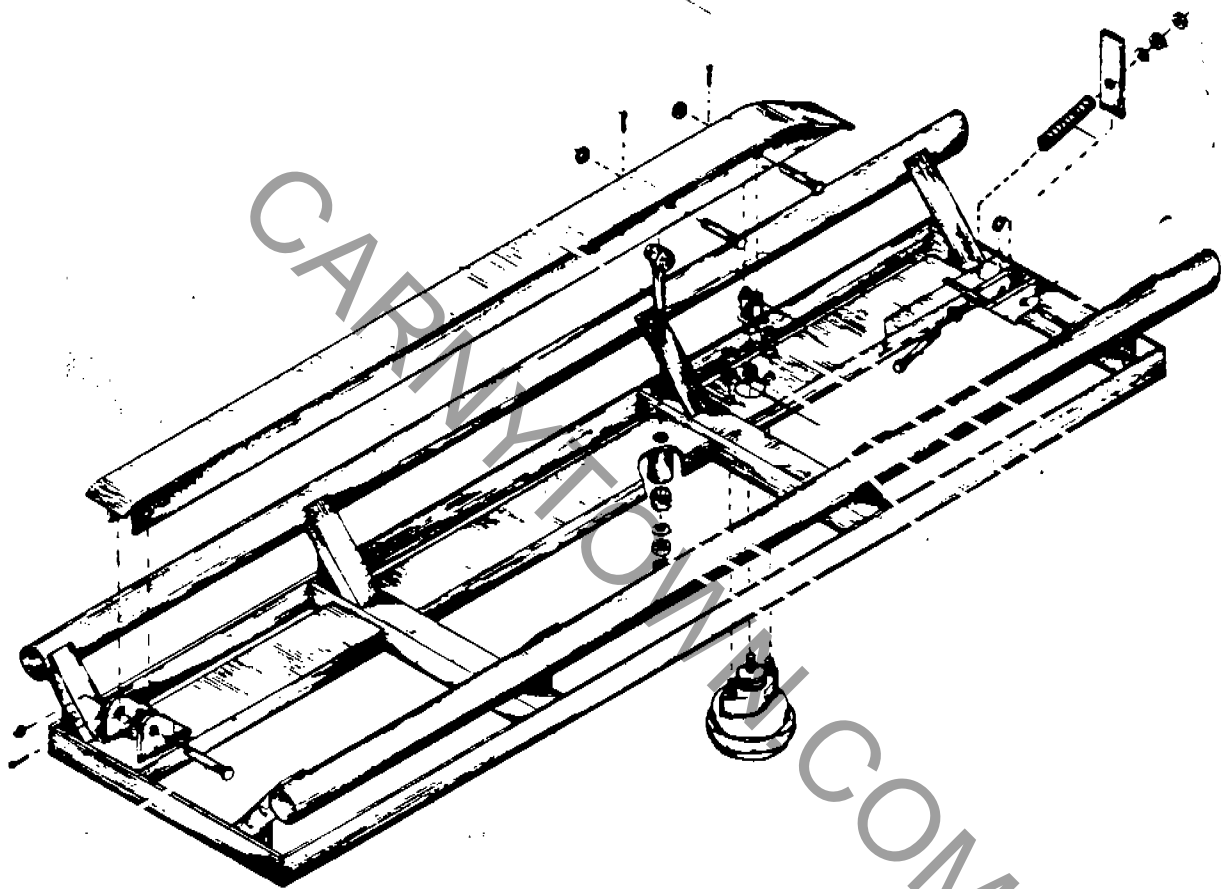

LOADING BRAKE -- BARREL ENTRY

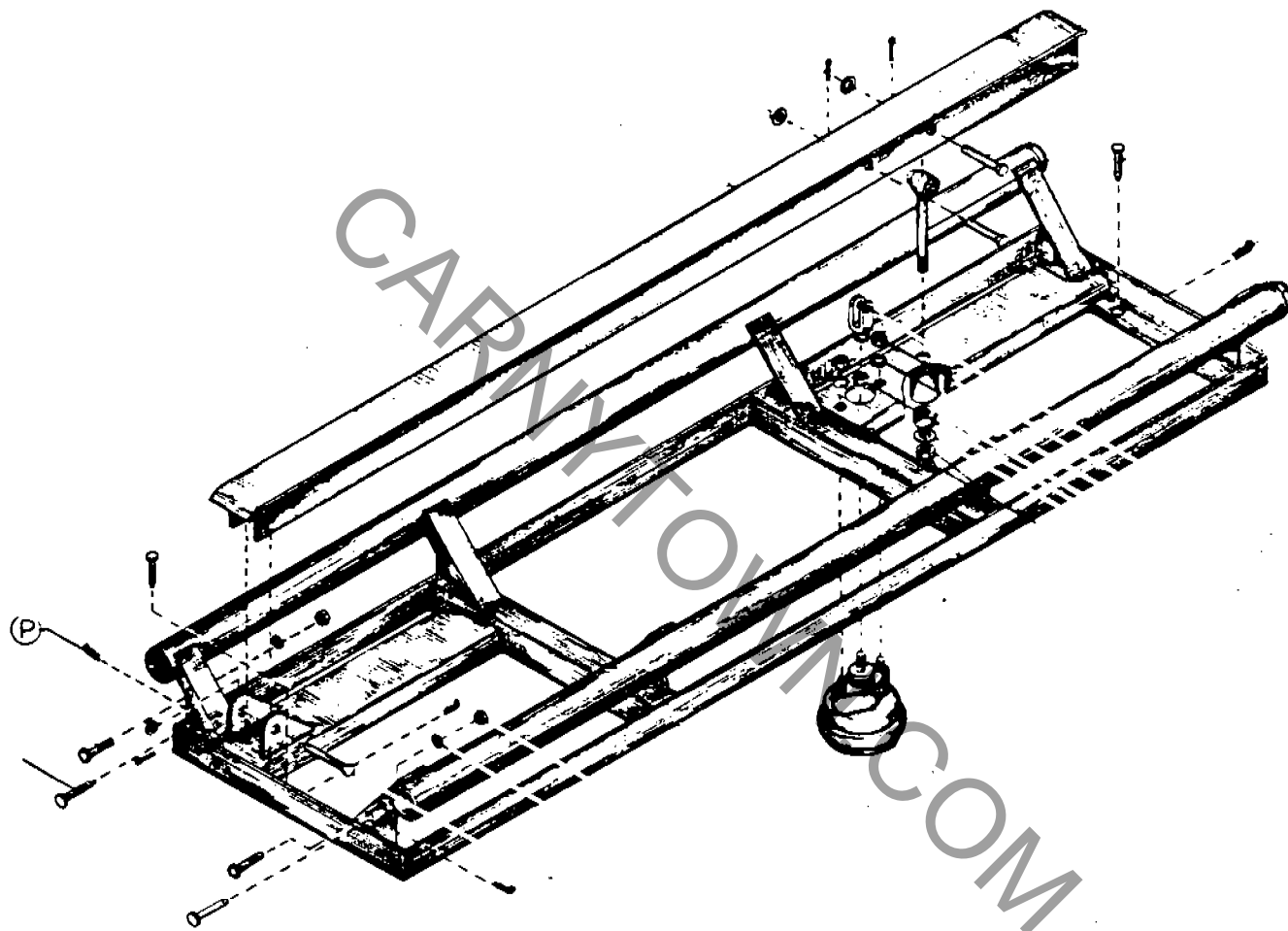

LOADING BRAKE
(4 sections)

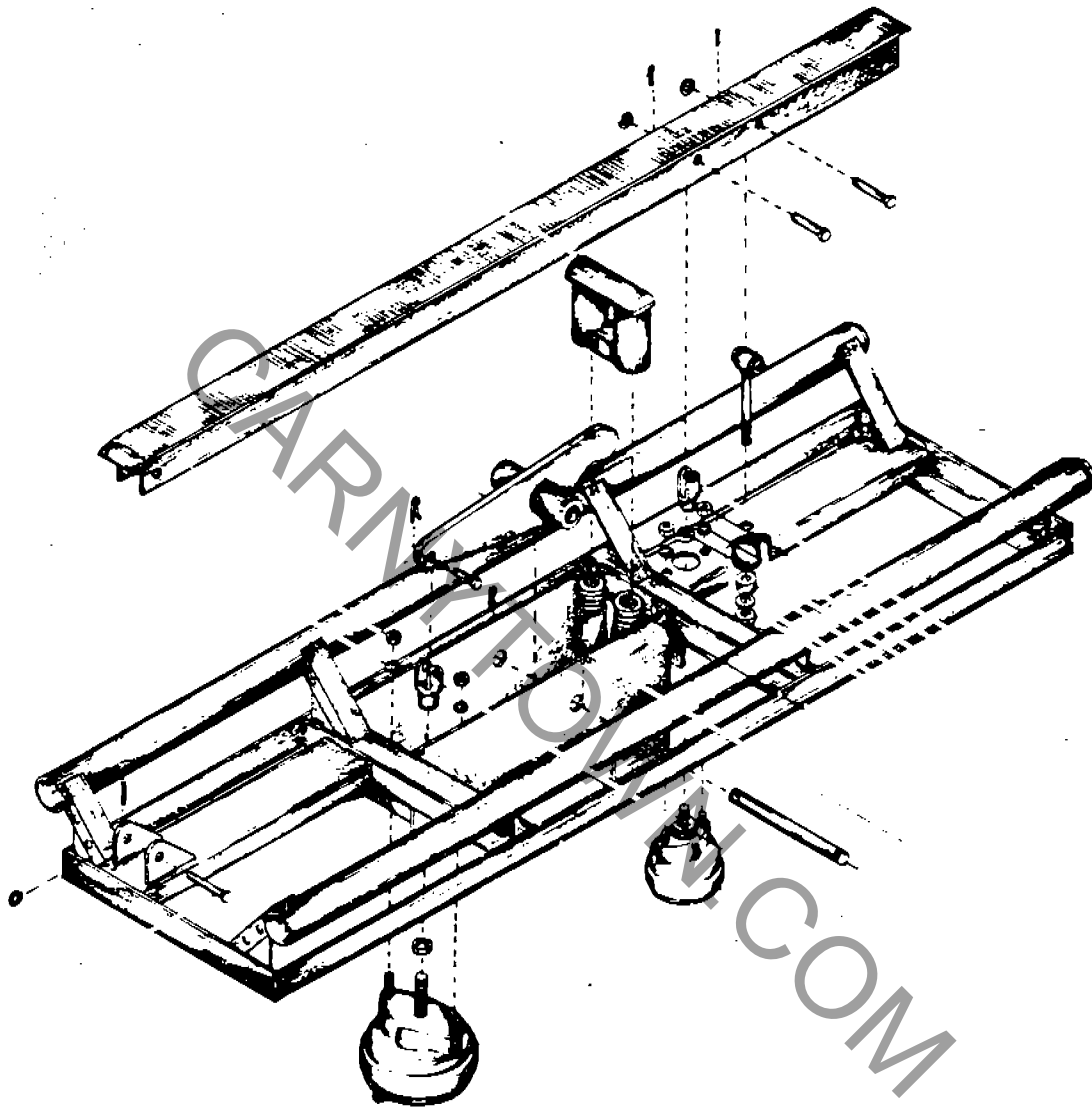

AIR LOSS - SAFETY BRAKE

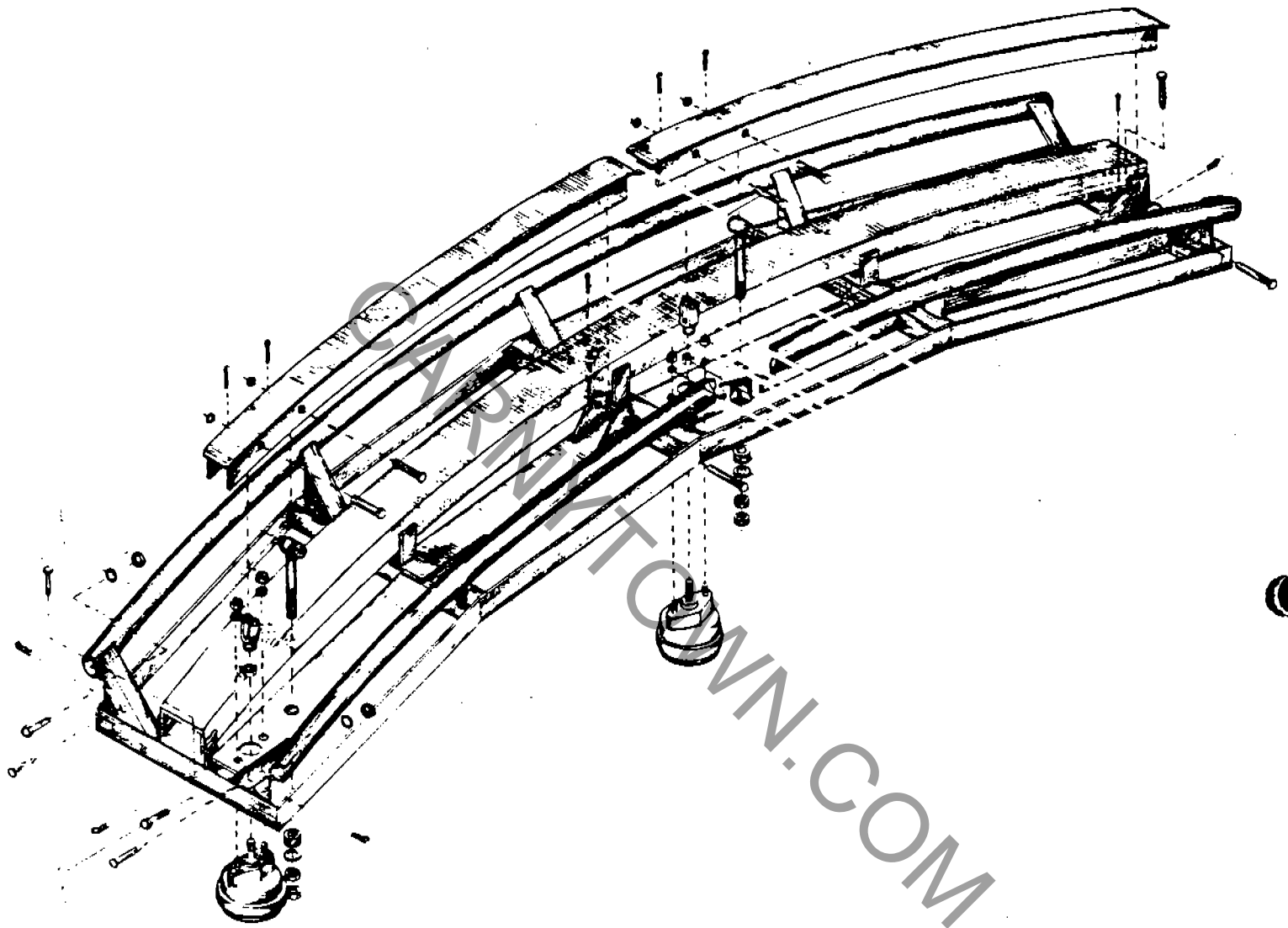

TOWER EMERGENCY BRAKE
(2 sections)

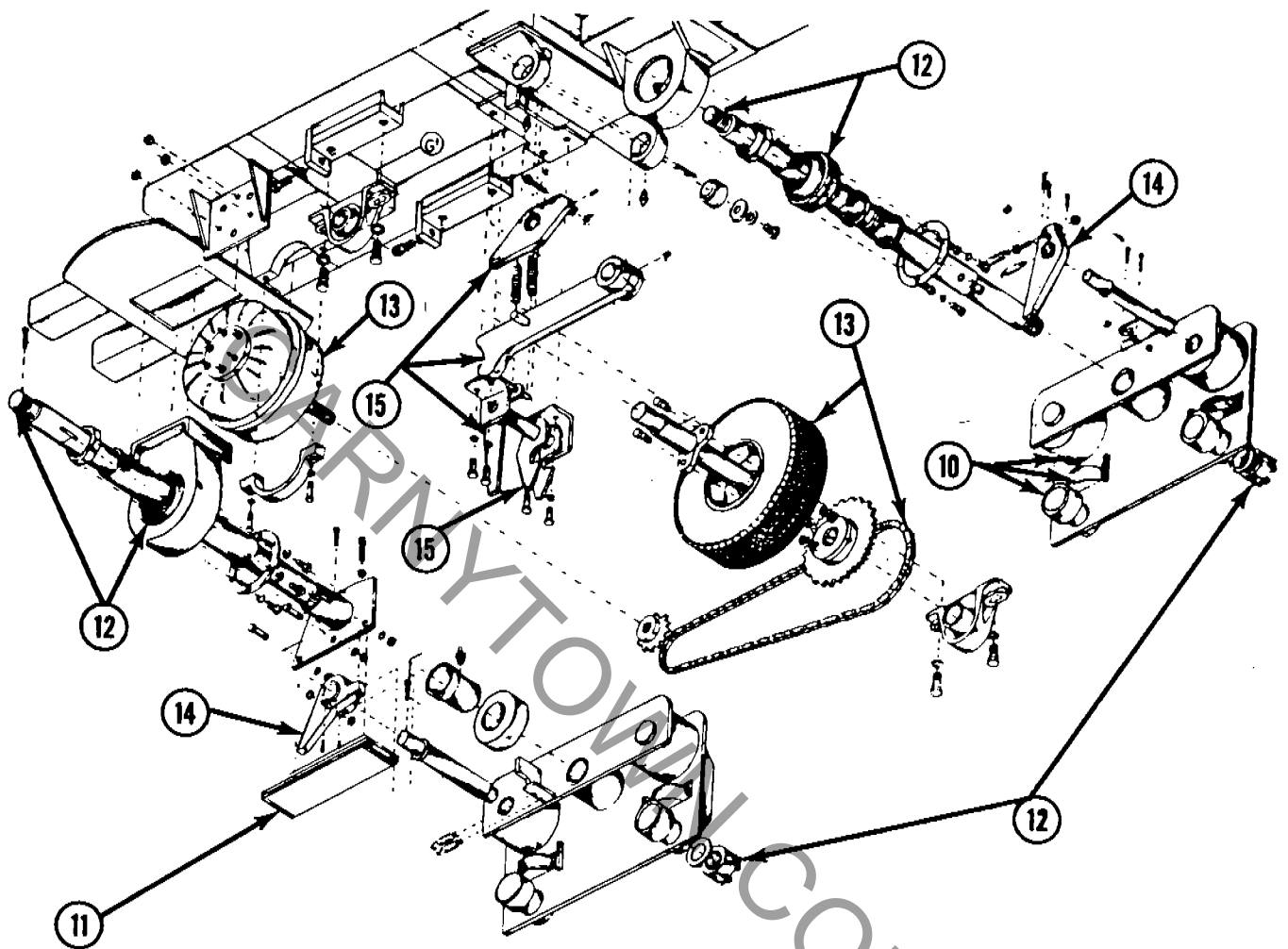

10. () Inspect all rollers on cars (Bulletin B107R1061-0).
11. () Inspect brake shoes on cars.
12. () Inspect axle pivot bearing on cars. Inspect threads on axles and castellated nuts.
13. () Inspect deceleration mechanism on cars.
14. () Inspect anti-roll back devices on cars (Bulletin B107R1061-0).
15. () Inspect pick-up dog and dog lock-up mechanism on cars (Bulletin B107R1061-0).

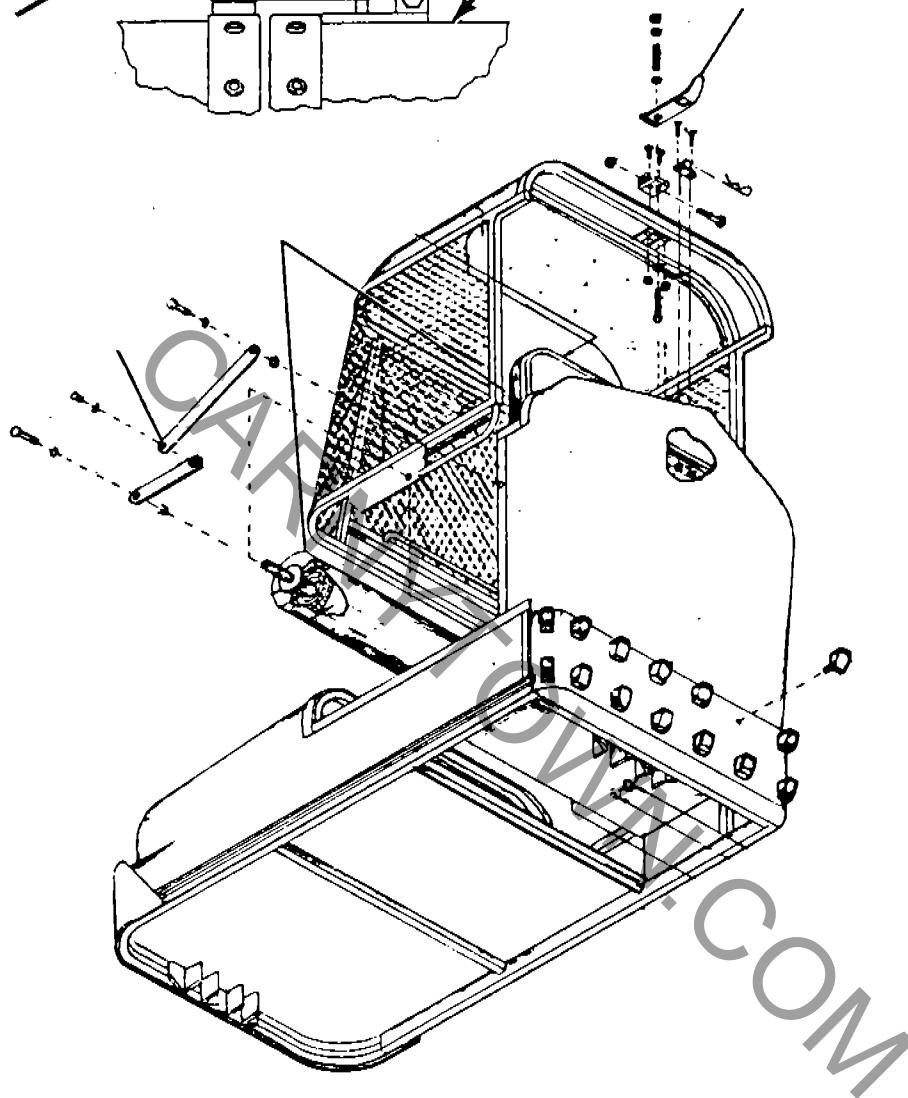
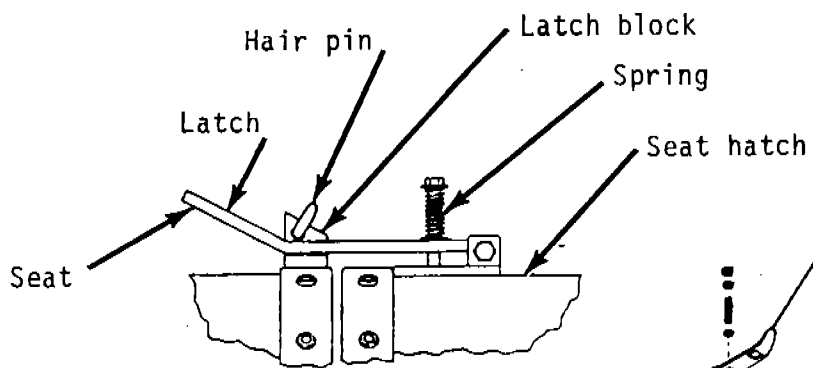

- 16. () Inspect condition of padding and lap bar in car.
- 17. () Inspect hinge joint on cars.
- 18. () Inspect hatch latching mechanism of cars
(Bulletin B06-0180-00).

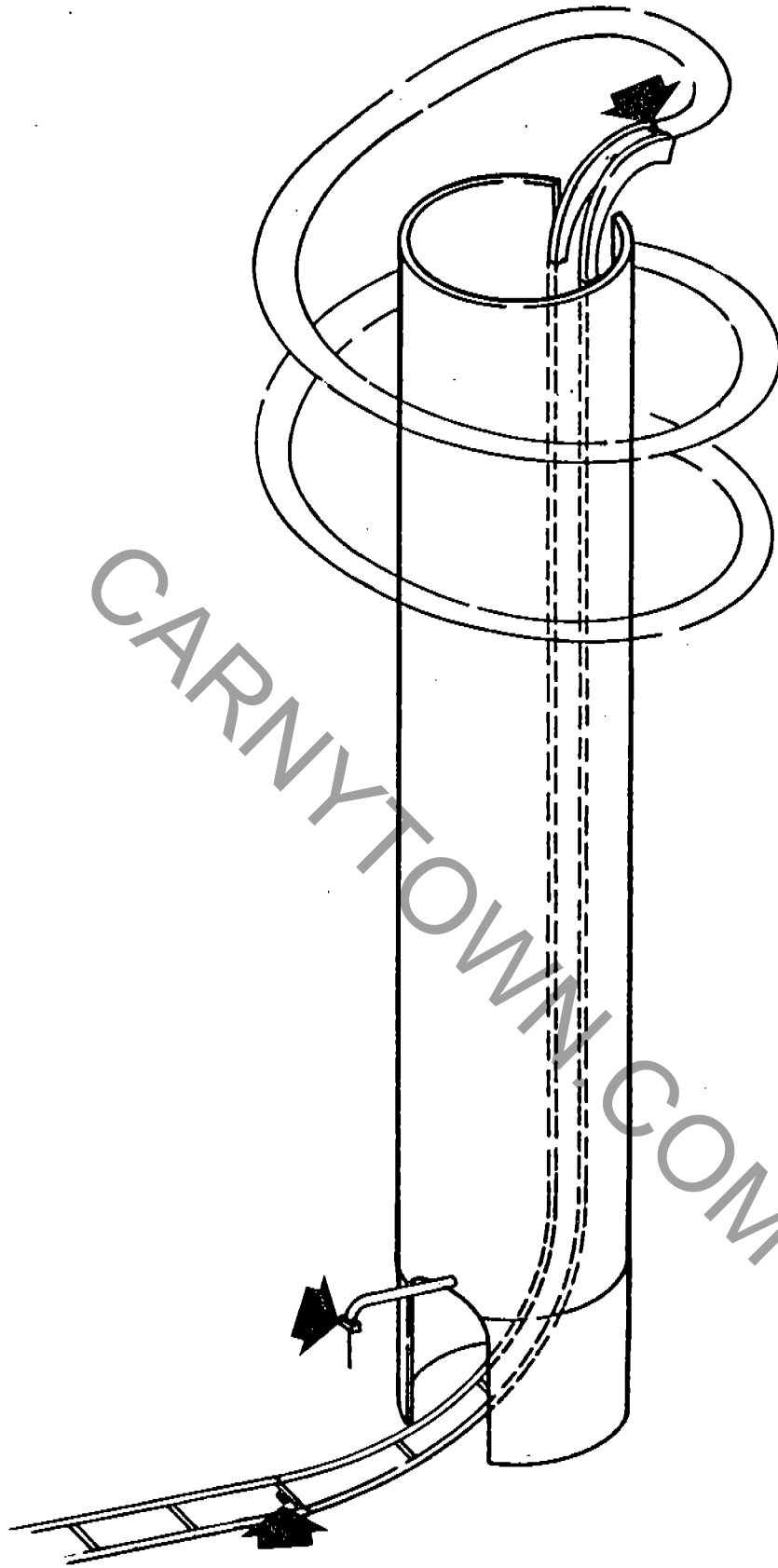

20. () Inspect hatch shut-off switch (Bulletin B107R1061-0).

21. () Inspect one car entry switches and bell (Bulletin B107R1061-0).

01 02 TOBOLLAH CAR CONTROL CIRCUIT 3-10-88

NF

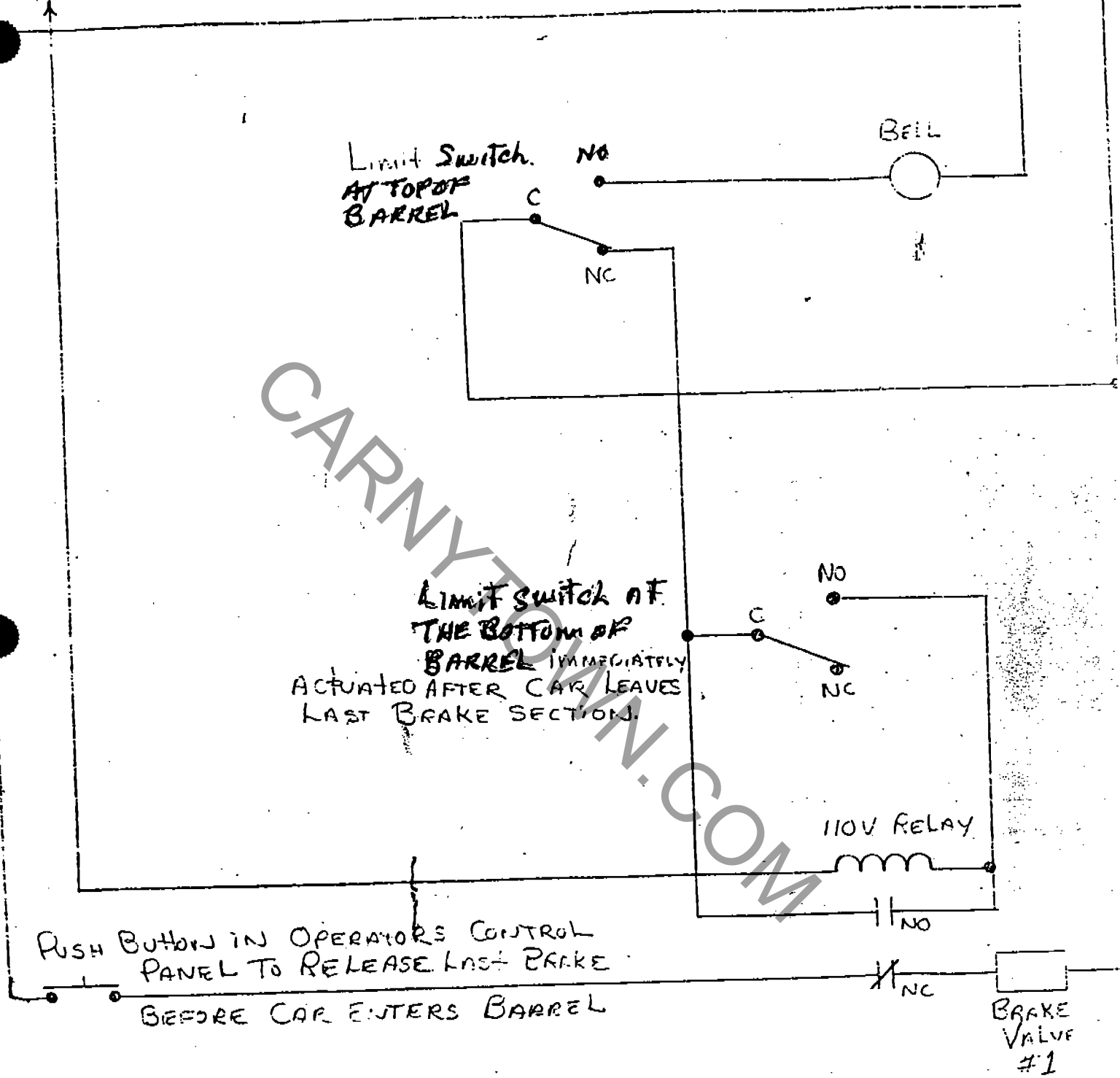

WHEN OPERATOR PUSHES NO.1 BRAKE VALVE BUTTON, NO. 1 BRAKE RELEASES ALLOWING CAR NO. 1 TO MOVE INTO BARREL. AS CAR NO. 1 MOVES INTO BARREL IT ACTUATES THE LIMIT SWITCH AT THE BOTTOM OF THE BARREL ENERGIZING THE 110 VOLT RELAY HOLDING THE RELAY CLOSED AND OPENING THE N/C CIRCUIT TO BRAKE VALVE NO. 1 PREVENTING THE OPERATOR FROM LETTING CAR NO. 2 INTO THE BARREL.

AS CAR NO. 1 MOVES UP THE BARREL IT ACTUATES A LIMIT SWITCH NEAR THE TOP OF THE BARREL WHICH RINGS A BELL AND DE-ENERGIZES THE 110 VOLT HOLDING RELAY INDICATING TO THE OPERATOR THAT CAR NO. 2 CAN NOW BE RELEASED INTO THE BARREL.

67

USC 2

CARNY TOWN.COM

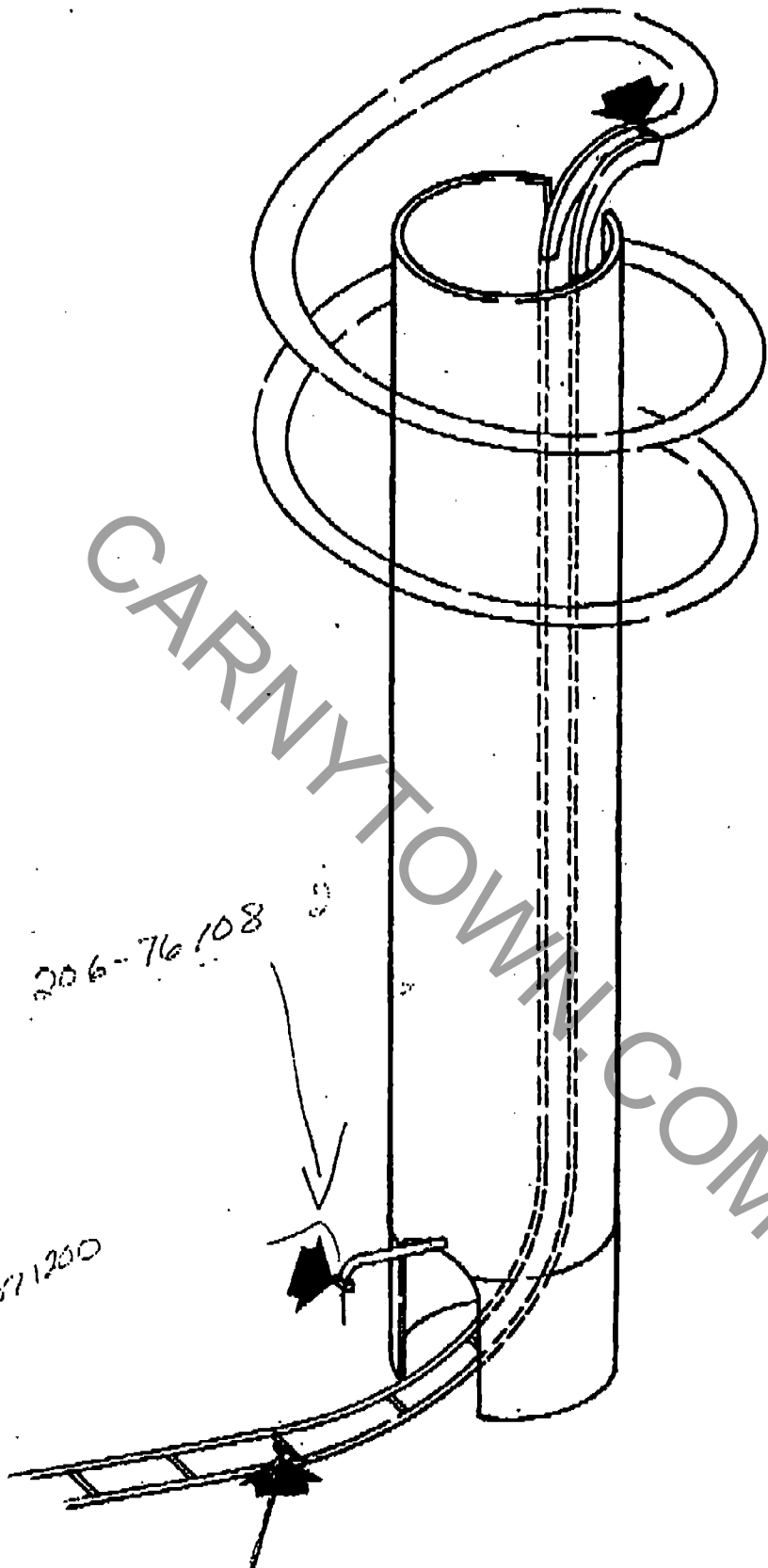

1071200

206-76108

2-76802

- 20. () Inspect hatch shut-off switch.
- 21. () Inspect one car entry switches and bell.

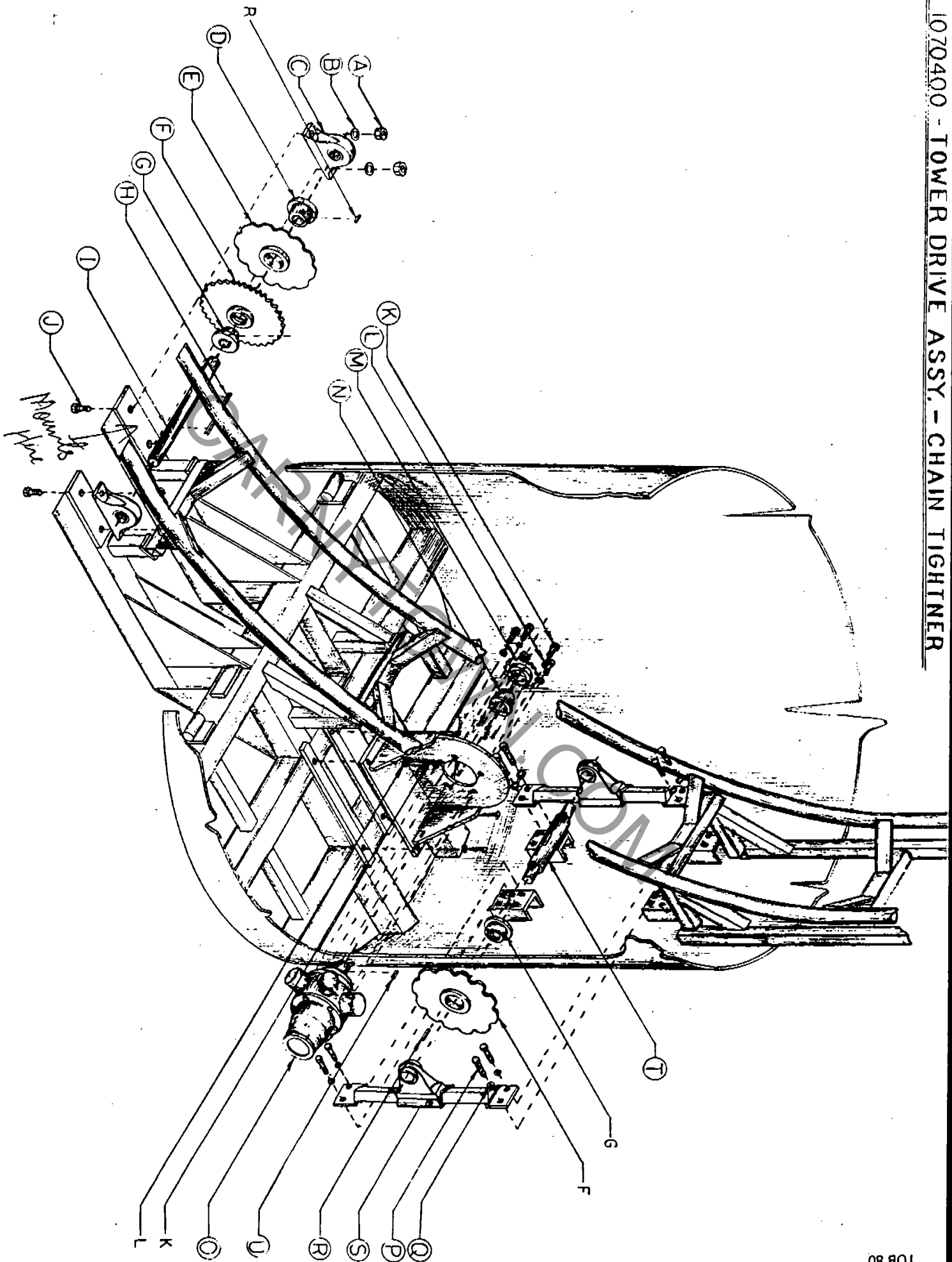

GOOSENECK ASSY.

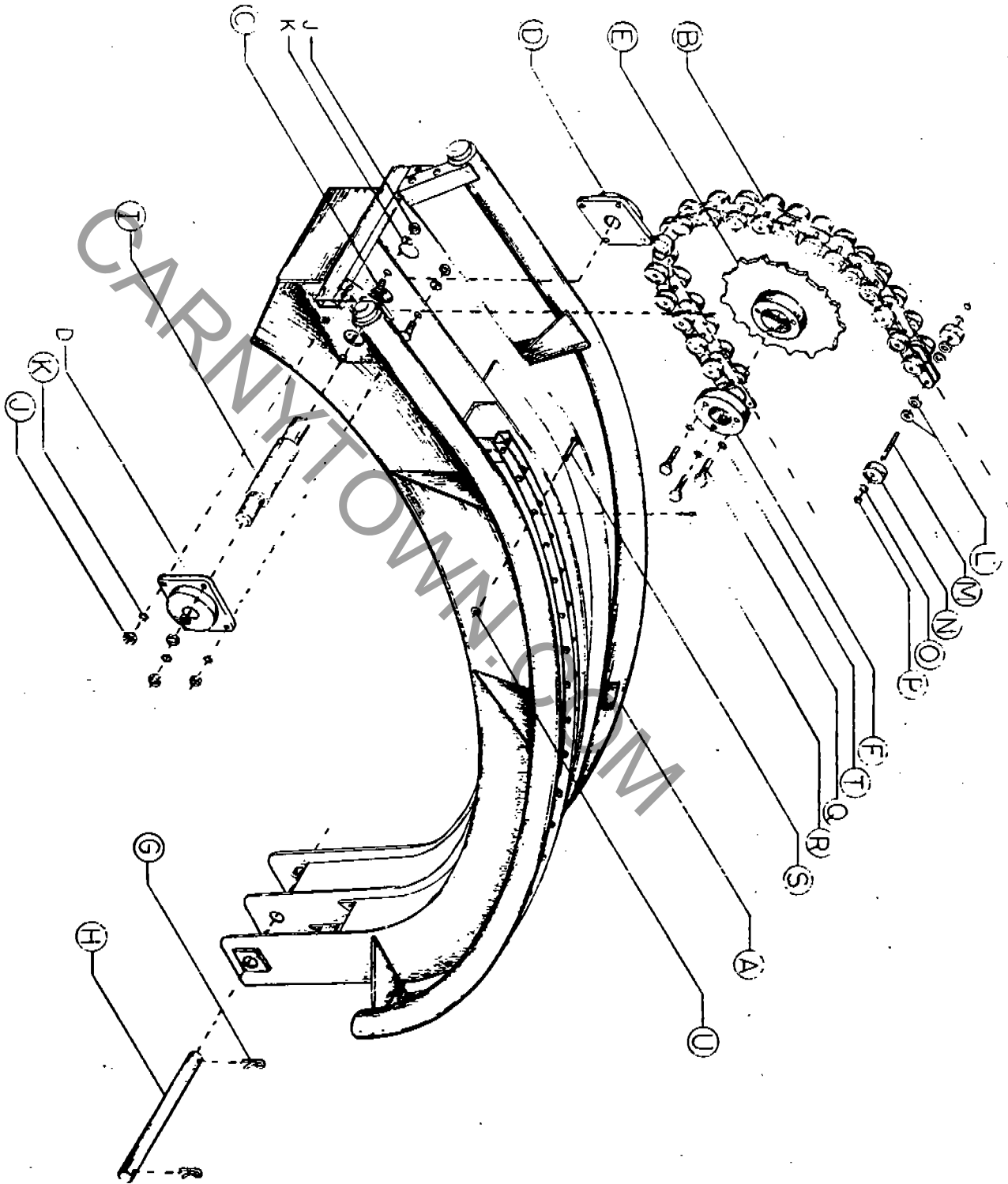

CARNYTOWN.COM



Number: B107R1061-0

Date: March 16, 1990

Supersedes: B06-0158A00

America's Largest Manufacturer of Amusement Rides

SERVICE BULLETIN

Effective Serial Numbers: ALL UNITS - Chance Manufacturing Co. Inc.

Chance Rides, Inc. SPECIFICALLY DISCLAIMS ANY LIABILITY for losses associated with rides produced by Chance Manufacturing Company, Inc.

Ride: TOBOGGAN

Subject: GENERAL INSPECTION

Service Bulletin B06-0158A00 has been superseded by this bulletin and is no longer in effect. All copies of B06-158A00 should be destroyed.

All TOBOGGAN owners are required to have the following inspections performed daily unless otherwise stated in this buttetin. These inspections must be performed by qualified personnel, capable of understanding the function of the parts and their proper installation. If there are any questions regarding the instructions or the inspections contact the Chance Customer Service Department.

NOTICE

USE ONLY THOSE COMPONENTS AUTHORIZED, SPECIFIED OR PROVIDED BY CHANCE RIDE, Inc.

CHANCE RIDES, INC. SPECIFICALLY DISCLAIMS ANY LIABILITY FOR LOSSES ASSOCIATED WITH ANY UNAUTHORIZED ALTERATIONS AND/OR MODIFICATIONS OR ADDITIONS ANDF INSTALLATIONS OF UNAUTHORIZED COMPONENTS.

INSPECTION PROCEDURE

- I. Inspect the two anti-roll back assemblies on each vehicle (refer to Illustration A).
1. The adjusting capscrew must be centered over the stop.
 2. The adjusting capscrew must not be bent or broken.
 3. The adjusting capscrew is held firmly against the stop by two springs.
 4. The adjusting capscrew is adjusted properly when it rests on the stop and the bottom of the anti-roll back latch is $1/8''$ from the bottom of the safety track.

ILLUSTRATION A

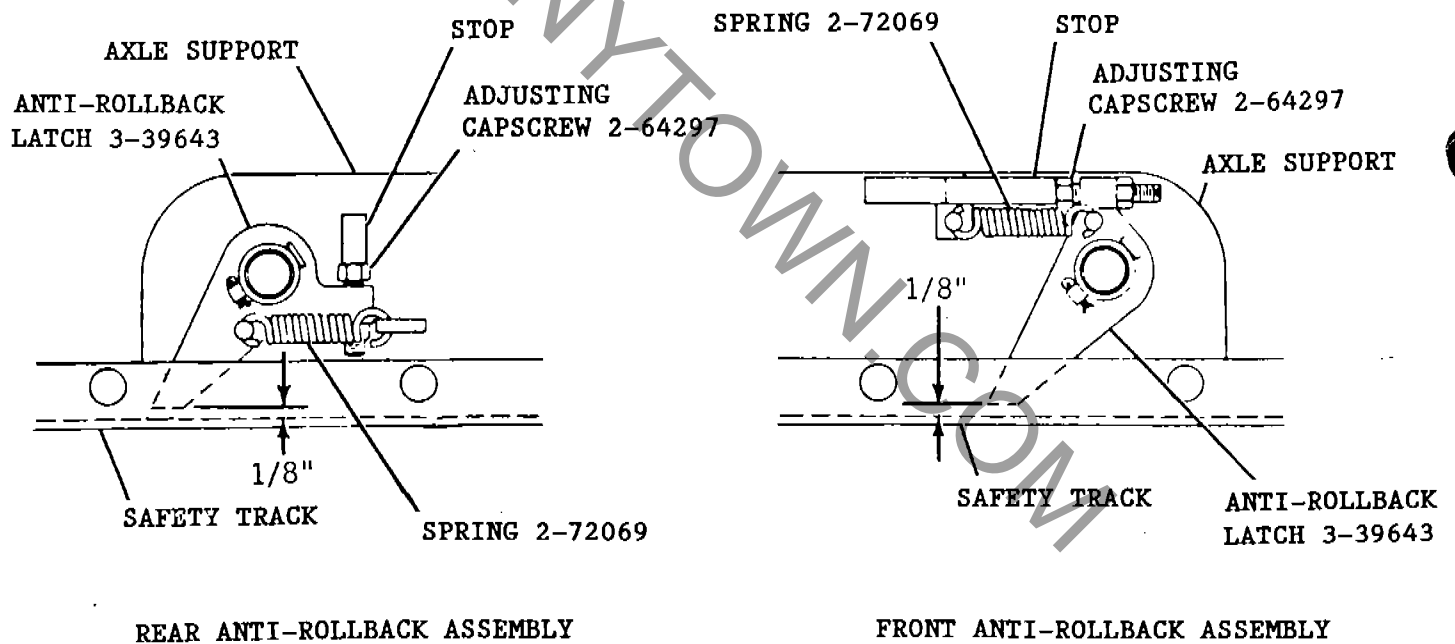

INSPECTION PROCEDURE (Continued)

- II. Inspect all parts of the chain dog assembly (refer to Illustration B).
1. The chain dog and chain dog pickup must be mounted securely to the mounting shaft by a key and set screws.
 2. The mounting shaft must move freely allowing the chain dog to swing downward from the latched position to the extended position.
 3. The chain dog is properly adjusted when the adjusting screw stops the chain dog at a 45 degree angle.
 4. When in the latched position the chain dog must be held securely by the latch.
 5. The chain dog latch and the trip arm must be held firmly against the stop by two springs.
 6. Inspect the welds that hold the chain dog latch and the trip arm to their mounting shaft.
 7. The chain dog latch and trip arm mounting shaft must be able to turn freely.
 8. As the vehicle leaves the top of the barrel the chain dog pickup up must contact the striker plate, pushing the chain dog up into the latched position. DO NOT OPERATE THE RIDE IF THE CHAIN DOG WILL NOT LATCH IN THE UP POSITION.

ILLUSTRATION B

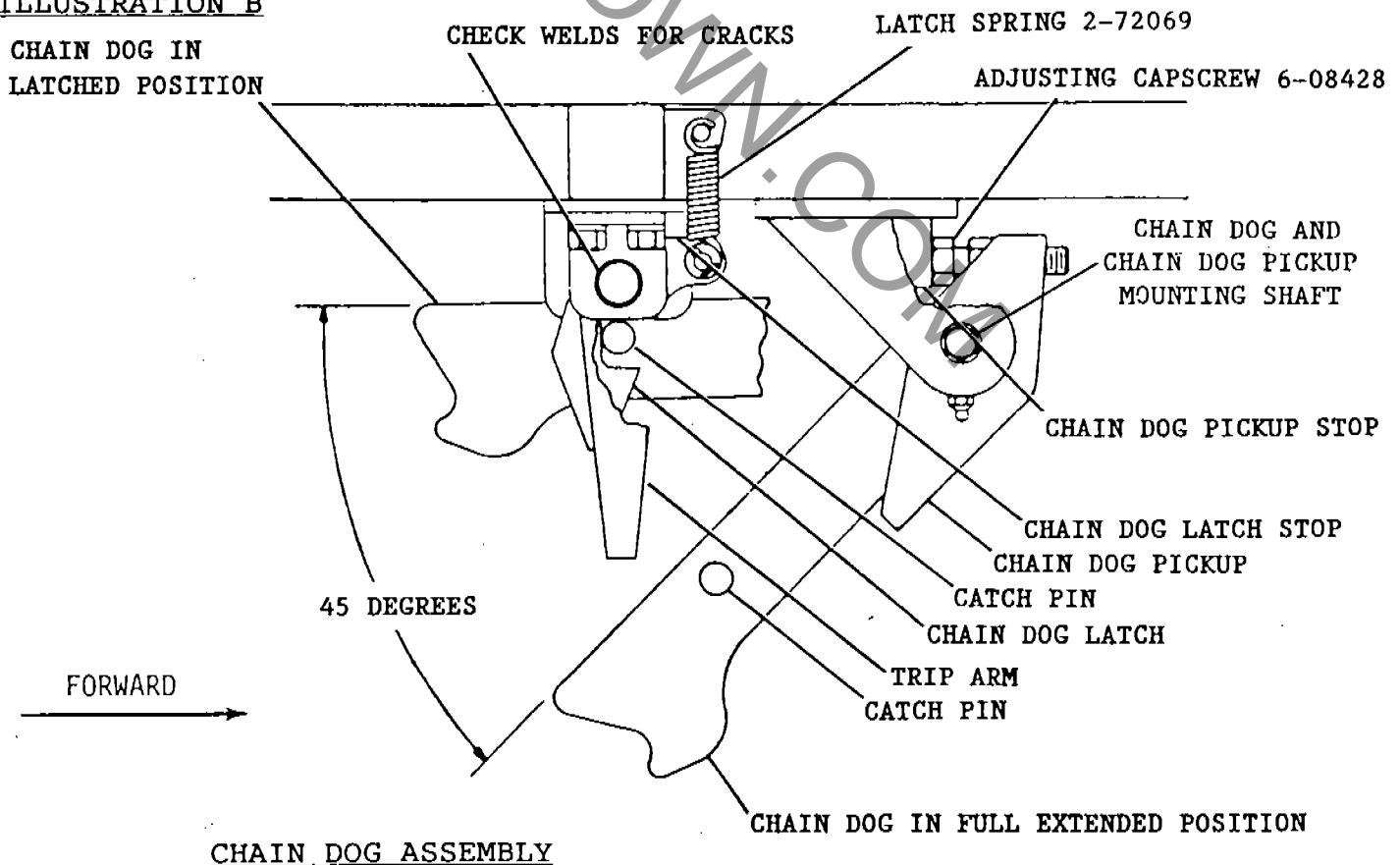

INSPECTION PROCEDURE (Continued)

- III. Inspect all top rollers, bottom cams, side rollers, and steel rollers of each vehicle (refer to Illustrations C and E).
1. Each axle has four side rollers, two at each end. If these rollers become worn or loose, the axle may move to one side and not allow the anti-roll back latch to be centered in the track. Inspect side rollers for wear, minimum outside diameter of roller must not be less than 3-1/2 inches.
 2. Side rollers must turn freely with no binding.
 3. The minimum allowable diameter of the top roller is 3-1/2 inches.
 4. The top rollers must turn freely with no binding.
 5. Bottom cam rollers must be mounted securely and turn freely with no binding.
 6. Inspect the two steel rollers on the main rear axle of each car by holding one side of the car down so that the roller is against the contact plate on the car frame, measure the clearance between the opposite roller and the contact plate. Total allowable clearance is 1/4 inch as shown in illustration E.
 7. Rollers must be able to turn freely with no binding.

ILLUSTRATION C

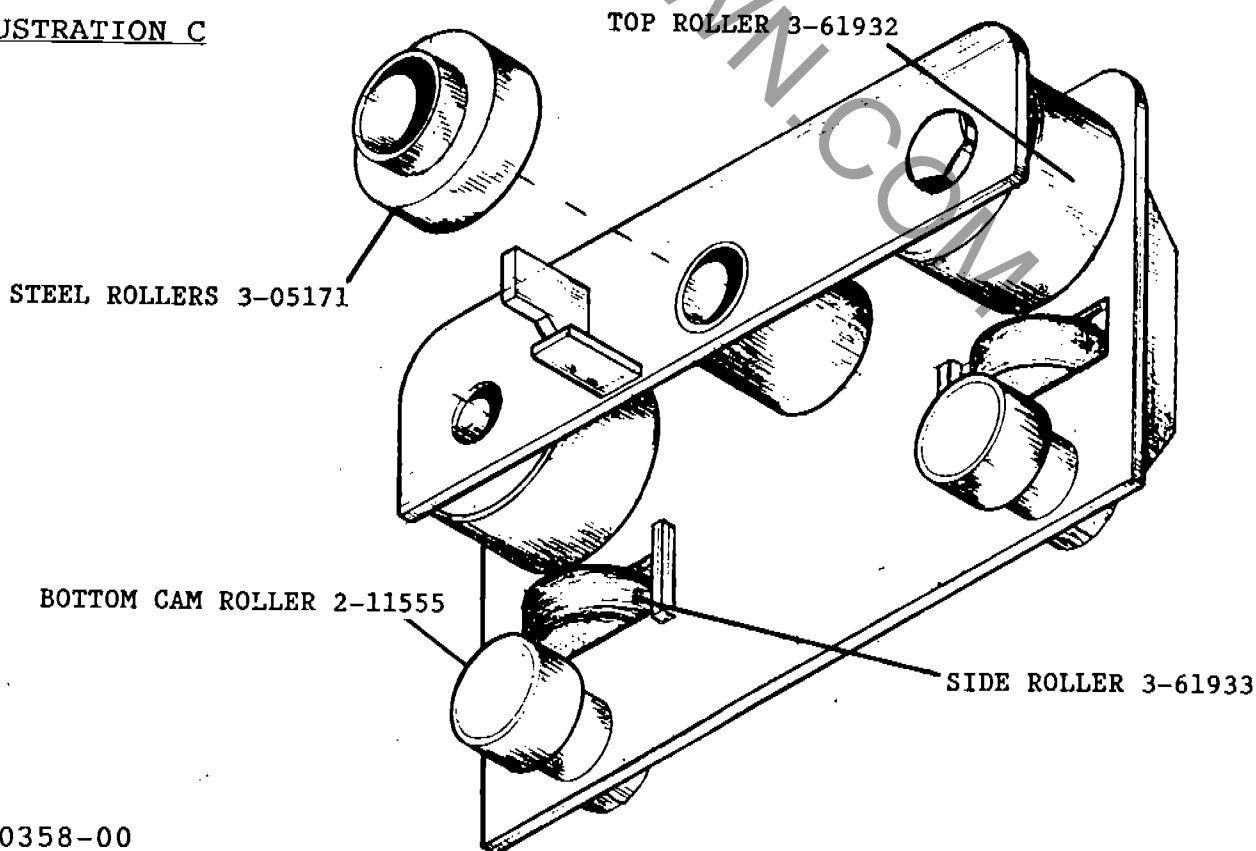

INSPECTION PROCEDURE (Continued)

IV. Inspect hydro sheave (refer to Illustration D).

1. With a torque wrench check the torque of the 3/8 inch hexhead capscrew located on the side at the center of the hydro sheave. The torque on this capscrew must be 22 foot pounds.
2. With the car positioned level, check the fluid in the hydro-sheave. The fluid level helps control the speed of the car. An empty car should take at least 53 seconds from the time it enters the tube until the time it is stopped in the brake section adjacent to the loading station. DO NOT OPERATE ANY CAR THAT HAS A LOW FLUID LEVEL.
3. Inspect the chain and sprockets for wear and alignment. The chain must not have more than 1/2 inch of slack.
4. Check air pressure of rubber tire on each car, pressure must be 50psi.

ILLUSTRATION D

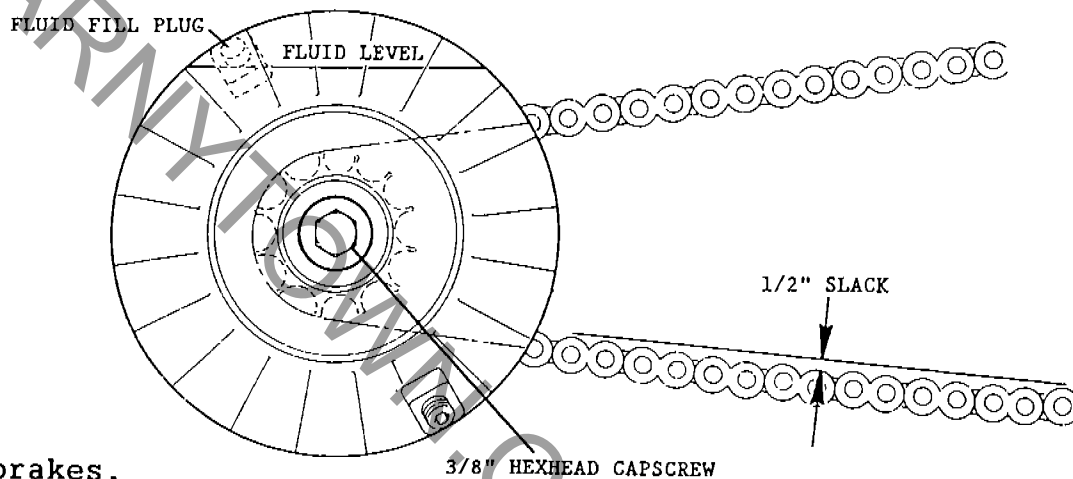

V. Inspect brakes.

1. Inspect the brake shoe located on the rear axle of each car. Brake shoes must not be less than 3/8 inch thick at the thinnest point.
2. Check for proper functioning of the two emergency brakes on tower spiral track by sending an empty car down the track while the emergency brakes are applied. Car must stop when it contacts the brakes.
3. Check for proper functioning of the emergency brake on the return tract by disconnecting the air line to the air chamber. The loss of air pressure will allow the two coil springs to apply the brake. When the air line is reconnected the air pressure will cause the air chamber to compress the springs and release the brakes. Check both springs to see that they are not broken.
4. Inspect the rubber stops that restrict the upward movement of the brake bars. Rubber stops should not be cracked, torn, or deteriorated.

INSPECTION PROCEDURE (Continued)

VI. Inspect safety blocks

1. Check the function of the limit switch at the entrance to the tower which shuts off the power to the chain drive when contacted by a car hatch which has been left open. With the chain running, activate the limit switch, the chain must stop.
2. Check the circuit which allows only one car in the tower at a time. Release the brake closest to the tower and allow a car to enter the tower. DO NOT ADVANCE THE OTHER CARS. While the first car is still in the tower try to release the brake closest to the tower again. It must not release until the car has exited from the tower. A bell at the top of the tower must ring as the car leaves the tower and moves out of this safety block.

VII. Inspect track (refer to Illustration E).

1. Inspect all track sections for wear. As track wears a flat spot develops. Any track section with a flat spot greater than one inch in width must be replaced. Any track section with a flat spot that has become concaved, regardless of its width, must be replaced.
2. Inspect all track sections for damage due to misuse or prolonged exposure to weather. Any track section that is bent from its original shape or does not line up properly with the next section of track must be replaced. Any track section that has holes in it due to rust or wear must be replaced.
3. Inspect safety track inside tower for worn or bent pins. Anti-rollback latch must be able to catch securely on all pins of the safety track.

ILLUSTRATION E

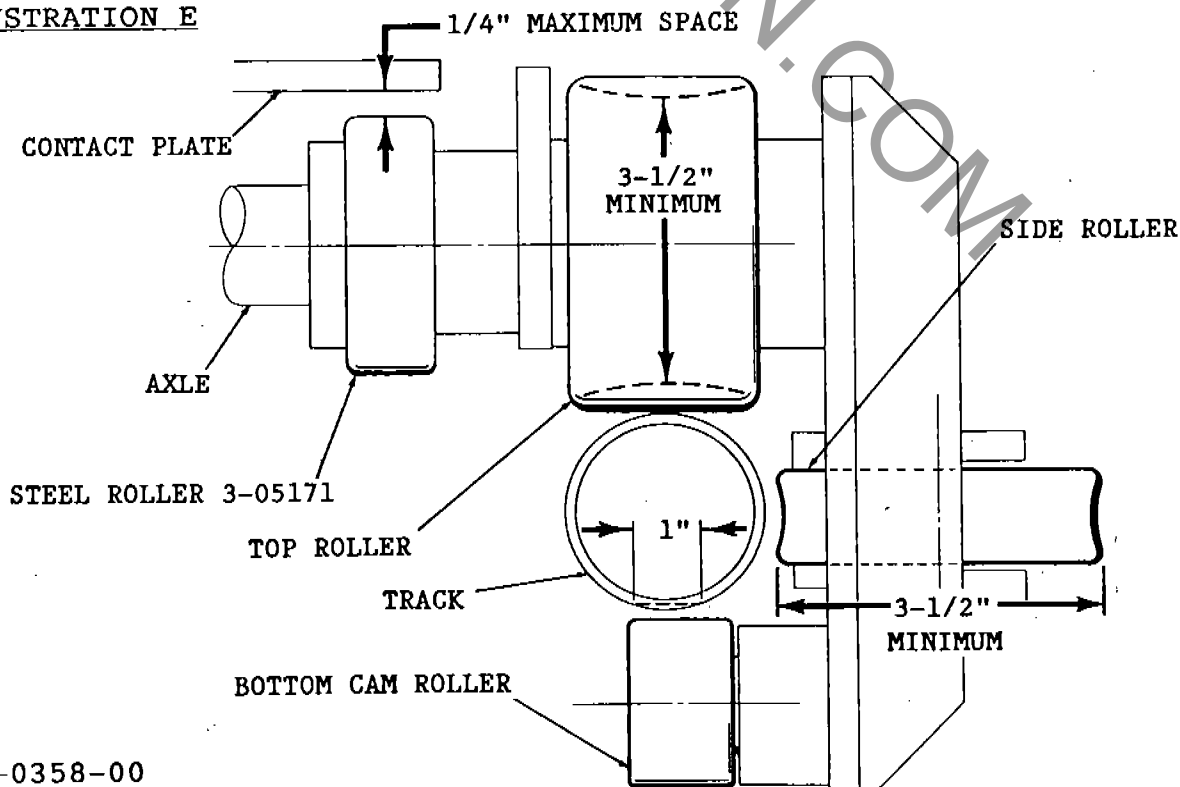



Number: B06-0180-00

Date: 1-22-79

Supersedes:

America's Largest Manufacturer of Amusement Rides

SERVICE BULLETIN

Effective Serial Numbers: ALL RIDES

Ride: TOBOGGAN

Subject: MAINTENANCE INSPECTION

If you no longer own this ride please notify Chance Manufacturing Co. of new owners name and address.

This bulletin is being issued to point out in detail several operating and maintenance practices on the Toboggan that are necessary to maintain the safety of the ride. These items should be checked daily along with the remainder of the FIELD INSPECTION POINTS listed at the end of this bulletin.

Inspection of the ride must be performed by competent, qualified mechanics capable of understanding the function of the parts and their proper installation.

All welding must be performed by a welder that is certified under the American Welding Society Structural Welding Code D1.1-75 or the equivalent.

All references to the Toboggan refer exclusively to the Toboggan Operations Manual and Parts Catalog dated January 6, 1972 on the front cover. All other manuals have been superceded and are no longer in effect. Copies of the current manual are available from the factory at no charge.

Page numbers are given with each heading and item call outs are given in the text for easy reference to the parts in the Turbo Manual.

SEAT HATCH LATCHES (SEE TOBOGGAN MANUAL PAGE 90)

Inspect seat door latches before each day's operation and when ride is set up. The spring operated latch is used as the primary latch and a hair pin is used as a secondary safety pin on the hatch latching mechanisms. Both the spring operated latch and hair pin latch must be in good working order before the ride can be operated. In no event should a seat be used if either one of the latches is not in good working order.

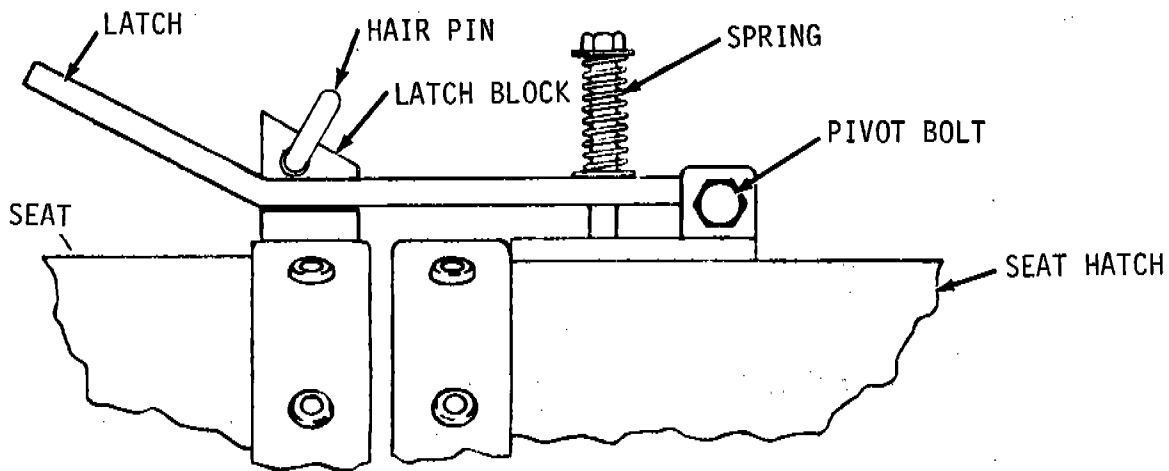

FIGURE A

The pivot bolts for the spring operated latch must be tight and the latch must pivot freely with no binding. The latch must close over the latch block without binding. The spring must not be distorted and must hold the spring latch tight against the shoulders on the latch block when the hatch is closed.

When the spring latch is in the latches position the hair pin hole in the latch block must be fully exposed. The amount of material between the top of the hair pin hole and the top of the latch block must fall within the tolerances shown in FIGURE B.

If the tops of the latch ears or the latch arm become worn beyond the allowable tolerance they may be built up by welding and then ground down to the allowable tolerance.

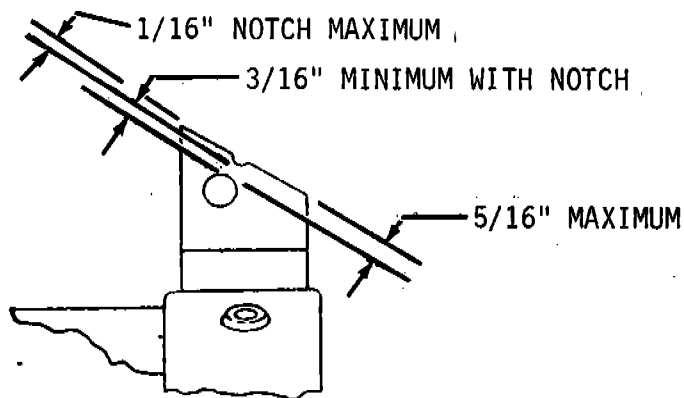

FIGURE B

Hair pins must be inserted and removed from the latch by hand only. If hair pin cannot be inserted by hand correct the misalignment condition.

A new hairpin inserted in a latch having maximum 5/16" edge of hole to edge of ear thickness (See FIGURE B) will require the maximum force to insert and remove.

A hairpin inserted in a latch having a worn or notched condition that reduces the edge of hole to edge of ear thickness to a minimum allowable of 3/16" (See FIGURE E), will require less force to insert.

Latch hairpins are expendable items and will become sprung after repeated use. Clearance at the inner lobe of the hairpin, FIGURE C, must always be at least 1/16" less than the edge of hole to edge of ear thickness or be replaced. This ensures a reasonable amount of force (approximately 8 pounds or more) will be required to insert or remove the hairpin. A hairpin that is easily inserted and removed must not be used under any condition.

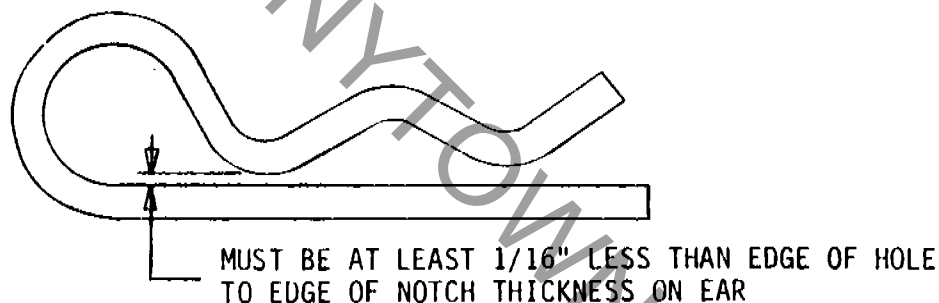

FIGURE C LATCH HAIR PIN

Do not use a hammer to insert or remove the hair pins. Using a hammer may cause the hair pin to turn to one side and be forced over the ear in a position where the material thickness is greater than the hair pin is designed for. This can cause the hair pin to be sprung beyond its usable dimensions. Do not insert hair pin past the second lobe.

SEAT HATCH LATCHES WHICH CANNOT BE MAINTAINED OR REPAIRED MUST BE REPLACED.

SEAT HATCH (SEE TOBOGGAN MANUAL PAGE 90)

Check to see that hinge bolts are tight and in good working order. Hatch must open and close without binding. Check all hinges for wear. Check the hatch linkage (D THRU M) on the left side of the hatch to see that it does not bind when the hatch is opened or closed. Attaching bolts for the hatch linkage and the lap bar must be tight. Plexiglass windows must be in place and unbroken.

Inspect car and hatch to see that there are no restrictions that will keep the hatch from closing properly. Do not fasten hair pin to car or hatch. Chain may fall in opening and restrict hatch from closing properly.

SEAT CONDITION (SEE TOBOGGAN MANUAL PAGE 90)

Check the general condition of the car. See that the screening is not torn or loose and that there are no sharp edges. The padding on the seat and on the lap bar must be fastened securely and not be torn or split.

HYDRAULIC SYSTEM (SEE TOBOGGAN MANUAL PAGE 54)

The most important thing with any hydraulic system is to keep it clean. Change filters twice yearly. After any work which opens up the system, such as an oil change or replacing or repairing the control valve, the filter should also be changed. When the oil is changed manually, the strainer inside the tank should be cleaned, also. Remove the strainer from the tank to clean. Clogged strainers will starve the pumps and ruin them beyond repair. Some of the first signs of damaged pumps are excessive pump noise or the ride running slowly, especially when the oil is hot.

It is very important to keep the oil at the proper level in the tank. The ride will operate on much less than a full tank, but the tank must be full when the ride is racked and the leveling jacks are raised, or the hydraulic system can overheat. Overheating can damage almost every component in the system. The recommended operating temperature is 140° to 180°.

LEVELING JACKS (SEE TOBOGGAN MANUAL PAGES 11 and 70)

Leveling jacks (page 11) have a stroke of 9" and are hydraulically extended and spring retracted. As the leveling jack reaches the end of its stroke the hand pump (page 11) will get harder to operate. The leveling jack should not be extended past this point as damage may result to the piston (Item D, page 70) and the ram spring (Item H, page 70). To help prevent overstroking place as much blocking as possible under the jack pads before extending the leveling jacks. Inspect leveling jacks for leaks each time the ride is set up or torn down. Leaks are usually the result of damaged seals (Item E, page 70) or scratched cylinder walls (Item B, page 70).

Hydraulic pressure may increase due to expansion when leveling jacks are exposed to heat such as direct sun light. The increased pressure may cause the leveling jack to raise the ride off of the locking rings (page 11) and make the ride unstable. After ride is leveled and locking rings have been tightened, open needle valves (page 11) and hand pump valve (page 11) to relieve pressure on the leveling jacks. When racking the ride, close the valves and operate the hand pump and the needle valves to extend each of the leveling jacks so that the weight is lifted off of the locking rings. Locking rings can then be backed off so that leveling jacks can be retracted.

ALIGNMENT OF TRAILERS (SEE TOBOGGAN MANUAL PAGE 12)

Check the alignment of the main trailer to the auxilliary trailer and see that the two attaching turnbuckles are tight. Check for movement of auxilliary trailer when car moves around curved section of track at end of auxilliary track. Screw jacks under auxillary trailer must be in place and tight.

TRACK (SEE TOBOGGAN MANUAL PAGES 57-68 and 76-85)

Check all sections of track, track braces and track supports for worn mounting holes, taper pins and hairpins. All turnbuckles must be tight.

LIFT CHAIN AND SPROCKETS (SEE TOBOGGAN MANUAL PAGES 19, 78 and 80)

Check car lift chain and sprockets at bottom and top of barrel for wear and alignment. Check sprocket shafts for wear. Chain must not have more than 3 inches of slack vertically between sprockets at bottom of tube. Check lift chain for broken rollers.

TOWER (SEE TOBOGGAN MANUAL PAGES 16 and 18)

Check tower lockup pins, bolts and holes for wear. Check for movement of barrel at bottom when car comes out the top of barrel.

GOOSENECK (SEE TOBOGGAN MANUAL PAGES 78 and 82)

Check gooseneck pivot pin (Item H, page 78) and hole for wear. Gooseneck turnbuckles must be tight.

RIDE SPEED

Check the speed of the ride by recording the time it takes for each car, when fully loaded, to complete a full cycle. Time must not be less than 45 seconds.

TORQUING OF BOLTS - (SEE SERVICE BULLETIN 90-148B)

All structural bolts must be periodically be checked for tightness. Refer to Service Bulletin 90-148B for proper torque values. Notify Chance Mfg. Co. of any bolts that are frequently found loose.

ADDITIONAL INSPECTION POINTS

Perform additional inspection points outlined in Service Bulletin B06-0158A00 and the Toboggan Manual.

The attached Certification of Compliance must be completed and returned to Chance Manufacturing Co. within seven (7) days of receipt of kit.

If you have any questions concerning this bulletin, please contact Chance Manufacturing Co. for assistance.

DAILY INSPECTION

1. Check spring latches to see that they open and close without binding.
2. Check spring latch springs to see that they are not distorted or broken.
3. Check to see that springs will hold spring latches in the latched position.
4. Check latch block to see that hair pin hole is fully exposed when the spring latch is depressed.
5. Check material thickness on latch blocks.
6. Check hair pins to see that they are not sprung.
7. Check operation of the hatches. Hinge bolts must be tight and hatches must open and close without binding.
8. Check attaching bolts for hatch linkages and lap bars.
9. Check to see that plexiglass windows are in place and unbroken.
10. Check for restrictions that would prevent hatches from closing properly.
11. Check seats for loose screening and sharp corners.
12. Check seats and lap bars for missing padding.
13. Check hydraulic oil for contamination and overheating.
14. Check hydraulic oil level.
15. Check leveling jacks for leaks.
16. Check leveling jack lock rings.
17. Check setting of hand pump valve and needle valves.
18. Check blocking under leveling jacks.
19. Check alignment of trailers to each other.
20. Check turnbuckles that tie trailers together.
21. Check for movement of auxilliary trailer during operation of ride.
22. Check the position and tightness of jackstands under auxilliary trailer.
23. Check lift chain and sprocket for wear and alignment.
24. Check adjustment of lift chain.
25. Check lift chain for broken rollers.
26. Check tower lockup pins, bolts and holes for wear.
27. Check for movement of barrel at bottom during operation of ride.
28. Check gooseneck pivot pin and hole for wear.
29. Check gooseneck turnbuckles for tightness.
30. Check speed of ride.
31. Check all structural bolts for proper torque.
32. Check ride for proper lubrication as outlined in the Toboggan Manual.
33. Check all maintenance points outlined in the Toboggan Manual.

NOTE: THE FOLLOWING INSPECTION POINTS ARE EXPLAINED IN DETAIL ON SERVICE BULLETIN B06-0158A00.

34. Check condition and adjustment of catch dog and spring.
35. Check the condition of the safety track.
36. Check for proper use of track clamp and J-bolt.
37. Check condition and adjustment of chain dog and chain dog pickup.
38. Check condition of chain dog latch, trip arm and spring.
39. Check all rollers and bearings on bottoms of cars.
40. Check condition of brake shoes on cars.
41. Check condition of track brake components.
42. Check the condition and operation of the emergency brakes.
43. Check the operation of the "hatch open" limit switch.
44. Check the operation of the circuit which allows only one car in the tower at a time.

THE FOLLOWING FIELD INSPECTION POINTS MUST ALSO BE CHECKED DAILY

1. Check for proper grounding per local code.
2. Check for proper installation of fences, steps and handrails.
3. Check ride for excessive vibration.
4. Check structure for cracks, bad welds, etc.
5. Check electrical circuit for shorts, bad wires, etc.
6. Check for hydraulic leaks.
7. Check rides' overall appearance for cleanliness and general external upkeep.

CARNYTOWN.COM