

SPECIFICATION

MFG: CHANCE RIDES, INC.
NAME: SKY WHEEL
TYPE: NON-KIDDIE

This ride conforms with all applicable ASTM amusement ride standards in effect on the date of m

SKY WHEEL

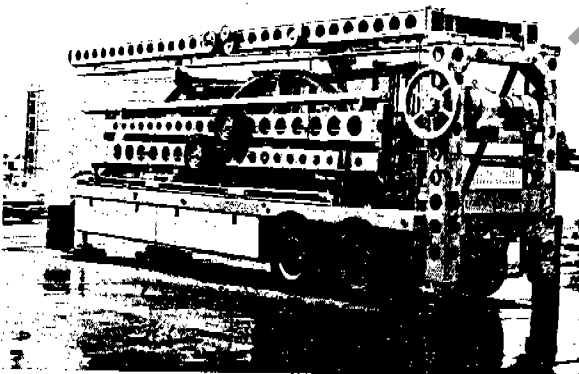
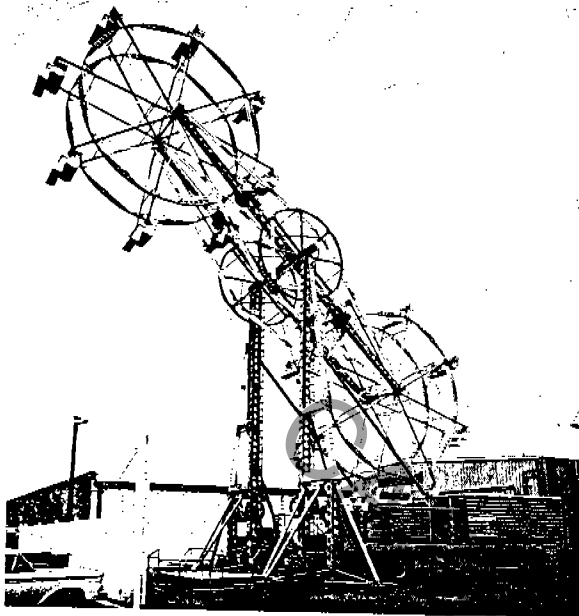

SEATING

Number of seats 16
 Maximum number of passengers
 per seat 2 adults or 3 children
 Maximum passenger weight per seat 340 lbs.
 Maximum total number of
 passengers 32 adults or 48 children
 Maximum total passenger weight 5,440 lbs.
 Minimum passenger height 42 inches
 (unaccompanied by adult)
 Loading 2 seats simultaneously
 Maximum unbalance
 Wheel 2 adults (340 lbs.)
 Boom 4 adults (680 lbs.)

PERFORMANCE

Direction of travel Clockwise and counter-clockwise
 Ride speed
 Boom speed 4 rpm
 Wheel speed 4 rpm
 Ride duration (maximum) 2½ min.
 Ride duration (recommended) 2 min.
 Maximum wind speed (operating) 35 mph
 Maximum wind speed (static) 80 mph

MAXIMUM RIDE WEIGHT (empty) 61,470 lbs.

DRIVE Electric

POWER REQUIREMENTS

Total 40 kW
 Drive 20 kW
 Lights 20 kW
 Minimum/Maximum line voltage 208/230

BOOM MOTOR

Quantity 2
 Type 208 Y/460 volt, 3 phase, 60 Hz
 Horsepower rating (each) 5

WHEEL MOTOR

Quantity 4
 Type 208 Y/460 volt, 3 phase, 60 Hz
 Horsepower rating (each) 3

LIGHTING 110 volt incandescent and fluorescent

STANDARD LEAD-IN CABLE

Size 2/0-5 conductor
 Length 100 ft.

TRAILERING

	Right Hand Trailer	Left Hand Trailer
Height	13 ft. 6 in.	13 ft. 6 in.
Width	8 ft.	8 ft.
Length	38 ft. 7 in.	38 ft. 7 in.
Total weight	27,850 lbs.	33,620 lbs.
Tire size	10:00 x 20 (12-Ply)	10:00 x 20 (12-Ply)

Specifications are effective as of publication date. Because we try to improve every Chance Rides product, these specifications are subject to change without notice.

Ground to high point of ride
79 ft. 3 in. with boom vertical.

7,500 lb. Each
Rear Jack (4 places)

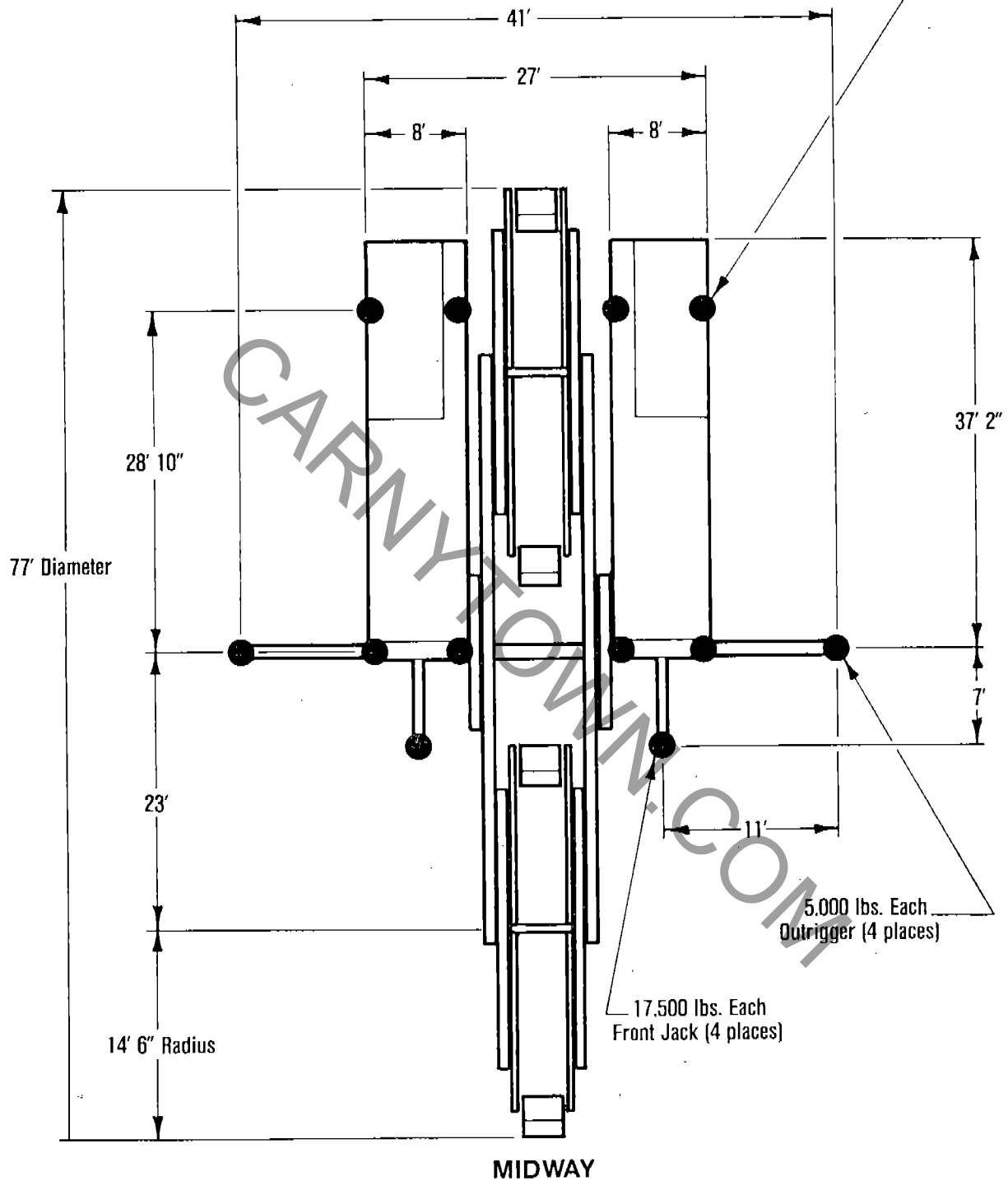

RIDE CLEARANCE DIMENSIONS

Frontage width	44 ft.
Ground depth	46 ft.
Maximum depth	83 ft. at center of wheel
Maximum height	83 ft.

CARNYTOWN.COM

SKY WHEEL

Ride Serial Number _____ Owner _____ Date _____

FIELD INSPECTION POINTS

1. () Inspect blocking and leveling.
2. () Inspect lock nuts on leveling jacks.
3. () Inspect hydraulic valves for leveling jacks.
4. () Inspect cable leads, electrical connections and grounding per local code.
5. () Inspect fences and platforms for proper installation.
6. () Inspect drive cable for cuts or wear. Spring tension - 350 pounds.
7. () Inspect drive rims, retainer plates and capscrews (Bulletin B47-0357-00).
8. () Inspect boom truss rods.
9. () Inspect cross rods in wheel assembly.
10. () Inspect wheel drive hold-down clamps.
11. () Inspect pins and safety pins in wind braces.
12. () Inspect spokes and spoke castings (Bulletins B160R1060-0 and B160R1063-0).
13. () Inspect rubber balls on sweep spindles. Measure the spread (Bulletin 99).
14. () Inspect seat spindles, snap rings and seat spindle bolts (Bulletins 99 and B47-0355-00).
15. () Inspect bolts in seat hinge castings.
16. () Inspect pin under seat spindle.
17. () Inspect seat latch and safety pins (Bulletin 96).
18. () Inspect keepers on lap bar hinge pin.
19. () Inspect holding brake.
20. () Inspect boom axle for cracks (Bulletin B379R1041-0. See Bulletin 111 for old style boom axle).
21. () Check speed of boom - 4 rpm maximum both directions.
22. () Check speed of wheels - 4 rpm maximum both directions.
23. () Inspect oscillation of seats.
24. () Check ride operation for excessive vibration.
25. () Inspect structure for cracks, bad welds, etc.
26. () Inspect electrical wiring for short circuits, bad wires, etc.
27. () Inspect for hydraulic leaks.
28. () Inspect overall appearance of ride for cleanliness and general overall upkeep.
29. () Inspect wheel axles.

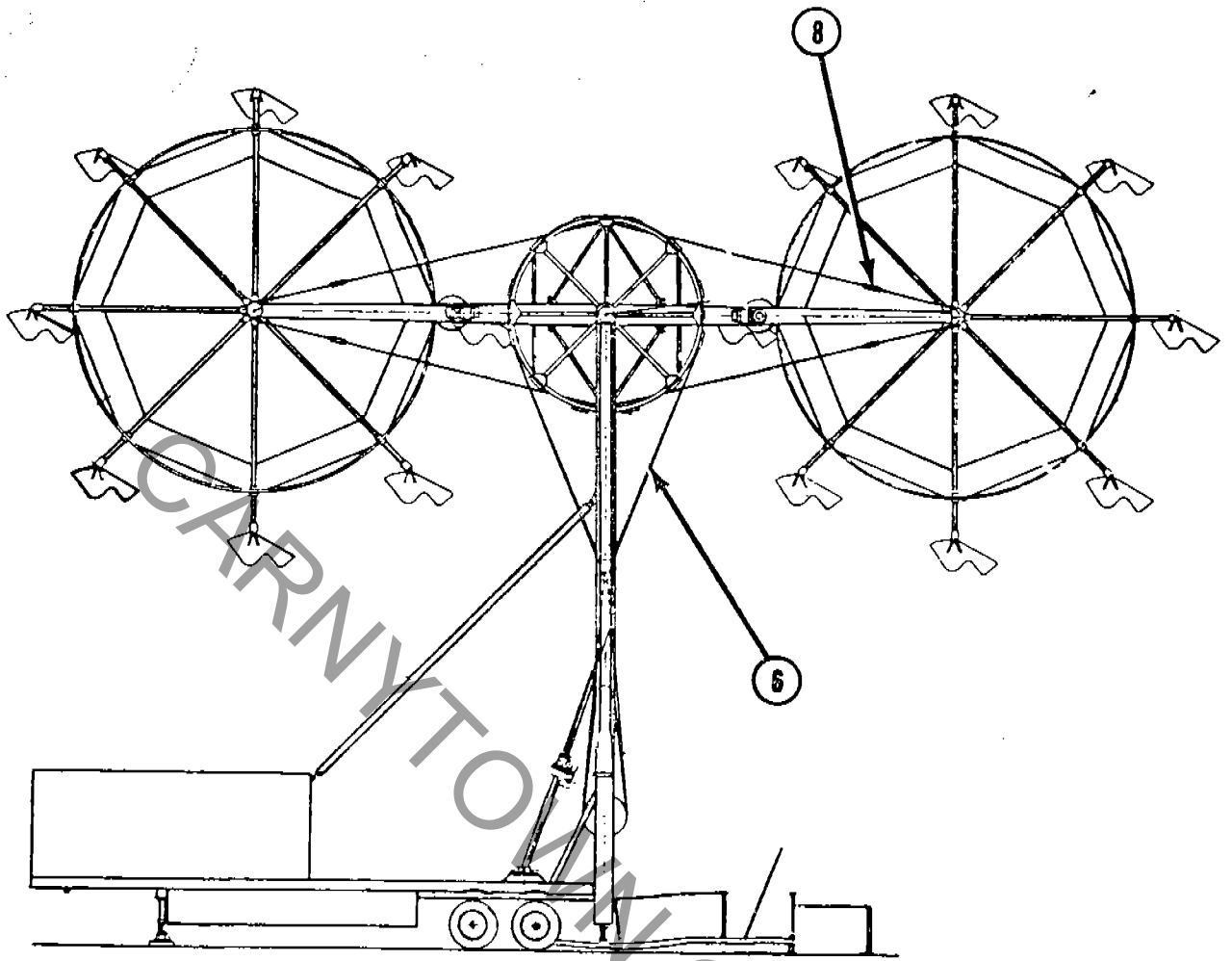

- 6. () Inspect drive cable for cuts or wear. Spring tension - 350 pounds.
- 8. () Inspect boom truss rods.
- 21. () Check speed of boom - 4 rpm maximum both directions.
- 22. () Check speed of wheels - 4 rpm maximum both directions.

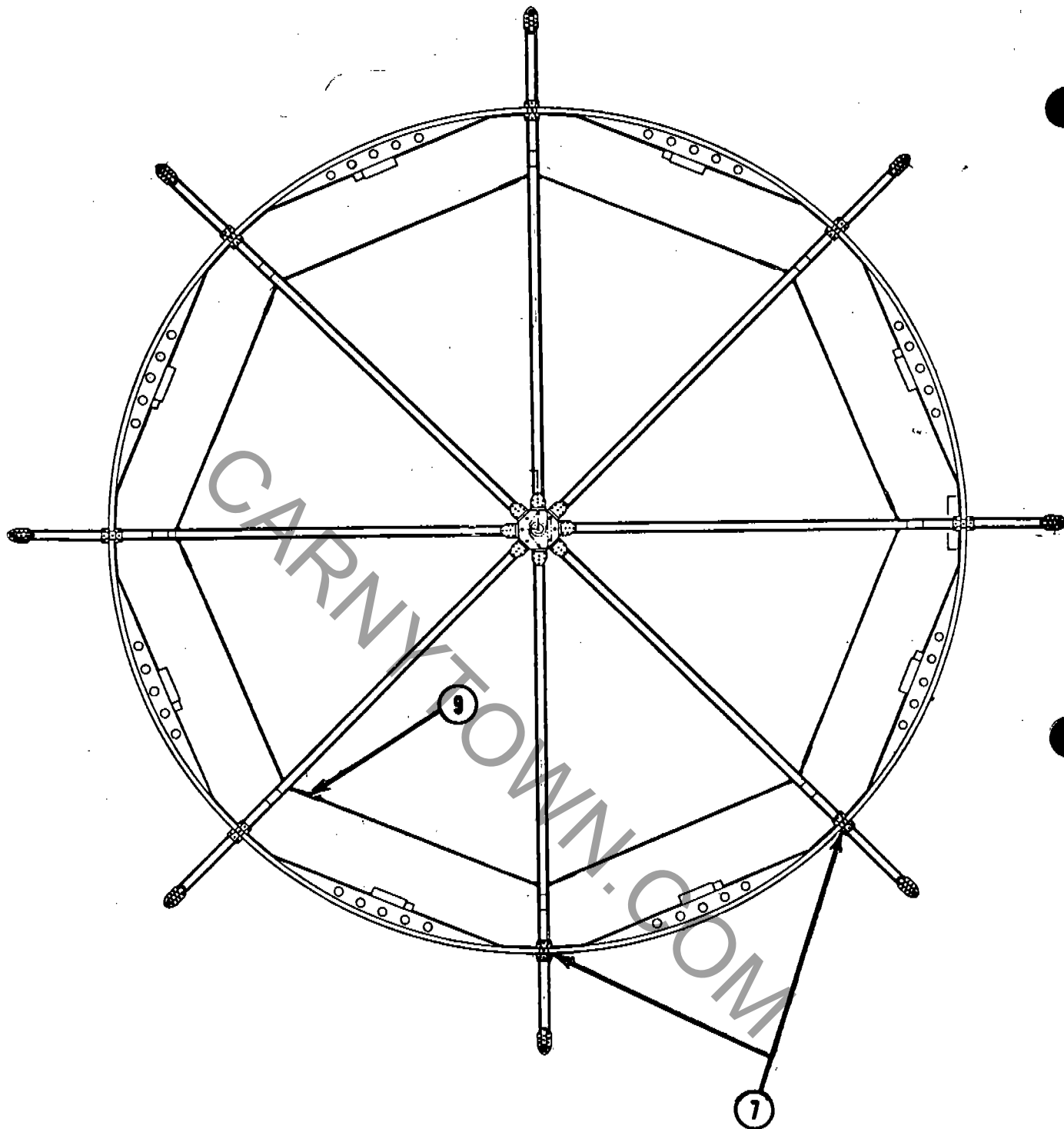

- 7. () Inspect rim irons, retainer plates and capscrews (Bulletin B47-0357-00).
- 9. () Inspect cross rods in wheel assembly.

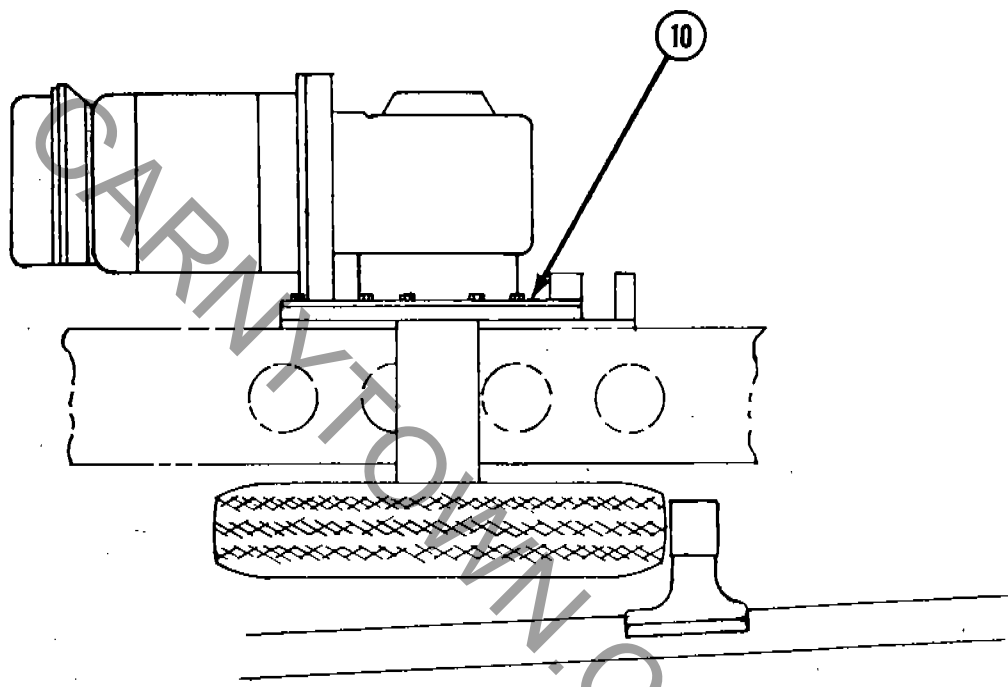

10. () Inspect wheel drive hold-down clamps.

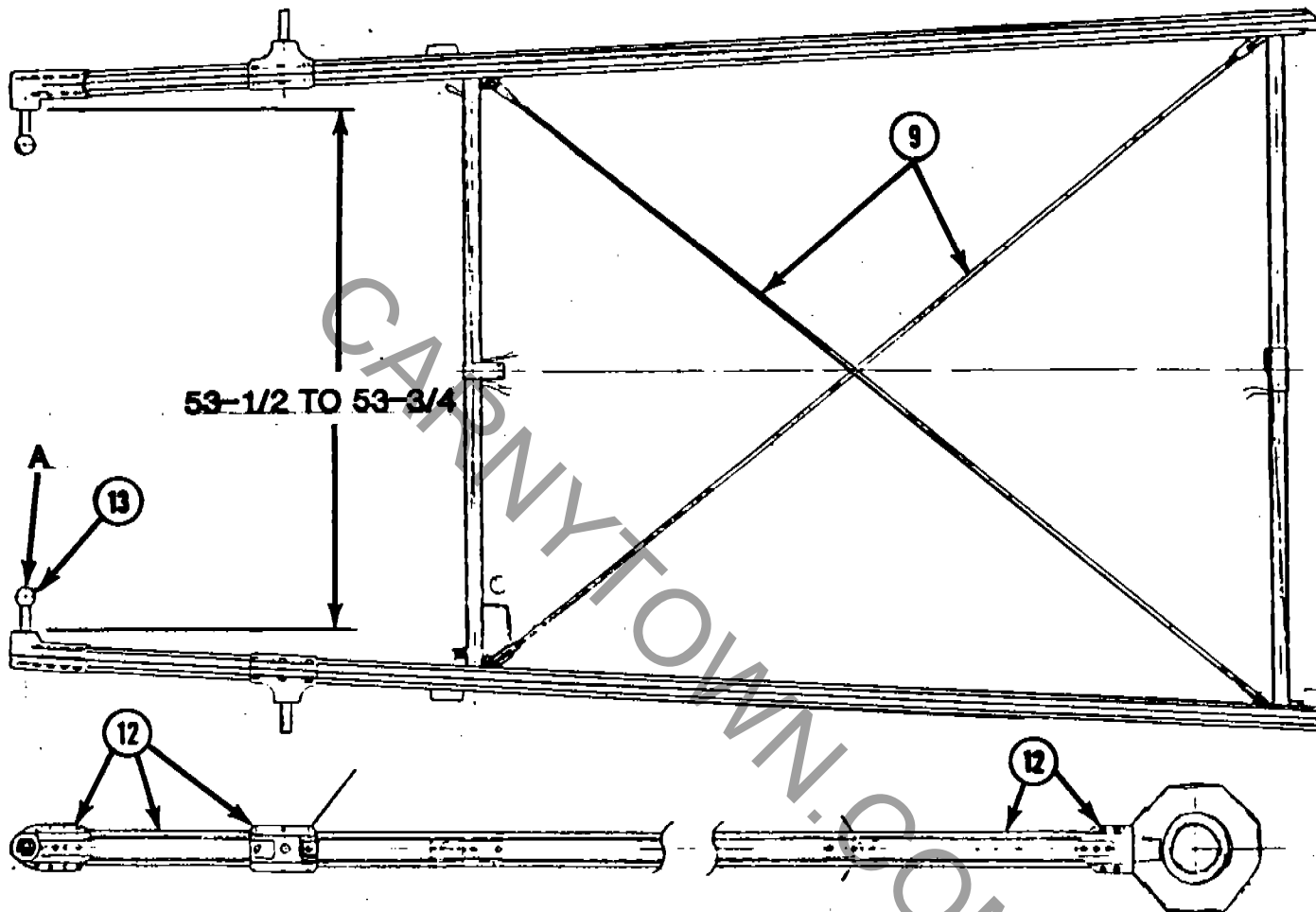

- 9. () Inspect cross rods in wheel assembly.
- 12. () Inspect spokes and spoke castings (Bulletins B160R1060-0 and B160R1063-0).
- 13. () Inspect rubber balls on sweep spindles. Measure the spread (Bulletin 99).

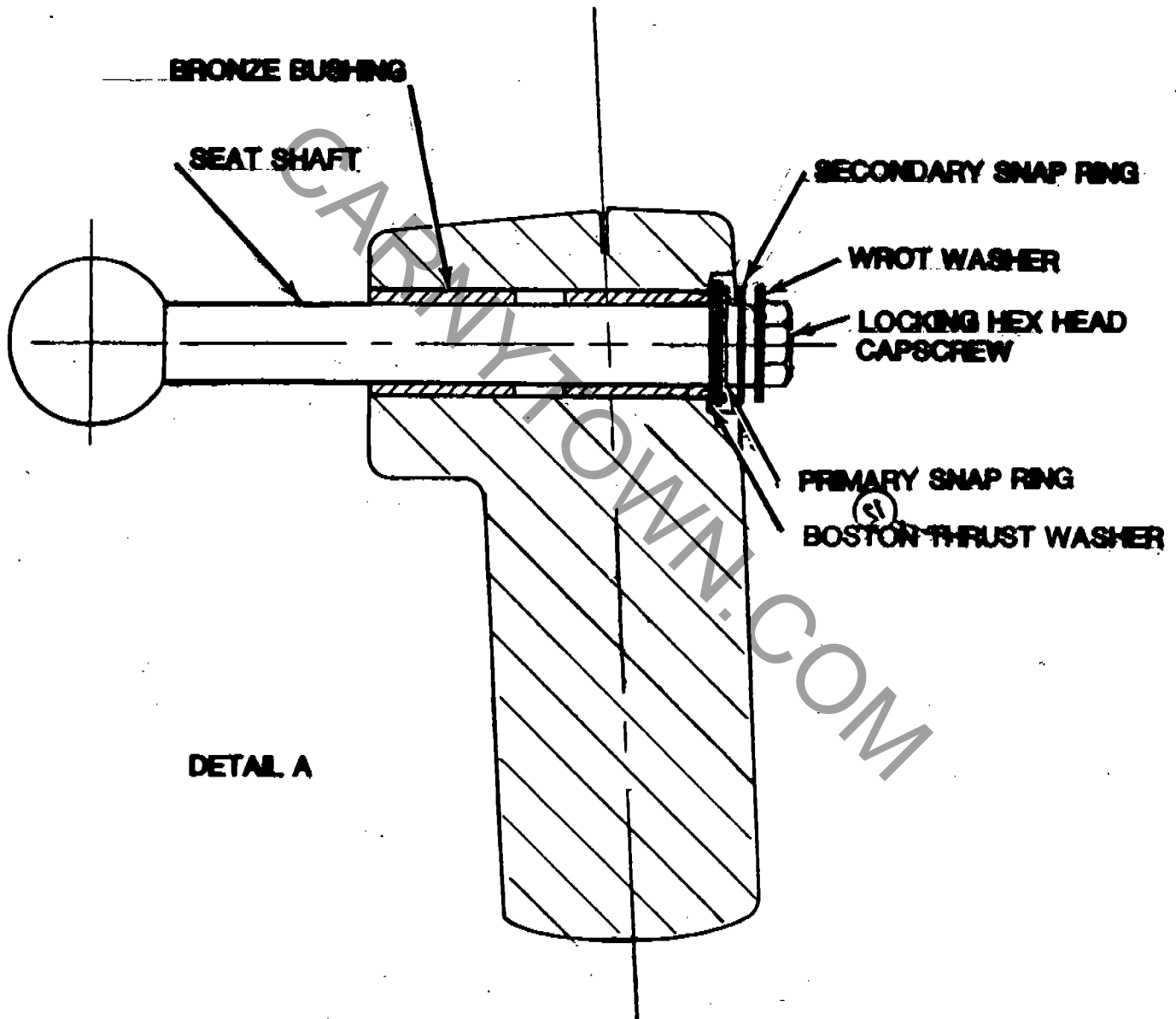

14. () Inspect seat spindles, snap rings and seat spindle bolts (Bulletins 99 and B47-0355-00).

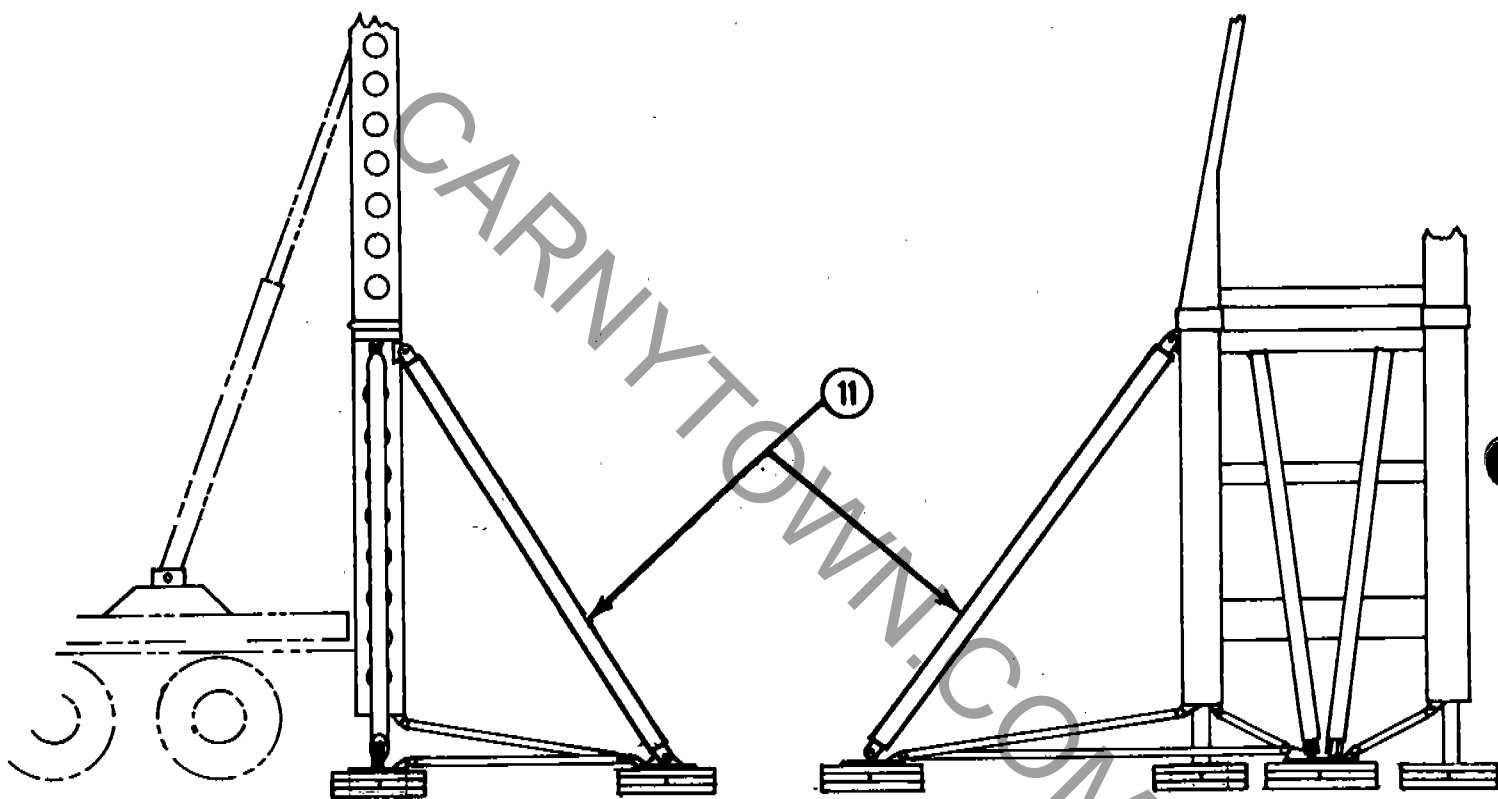

OLD STYLE

11. () Inspect pins and safety pins in wind braces.

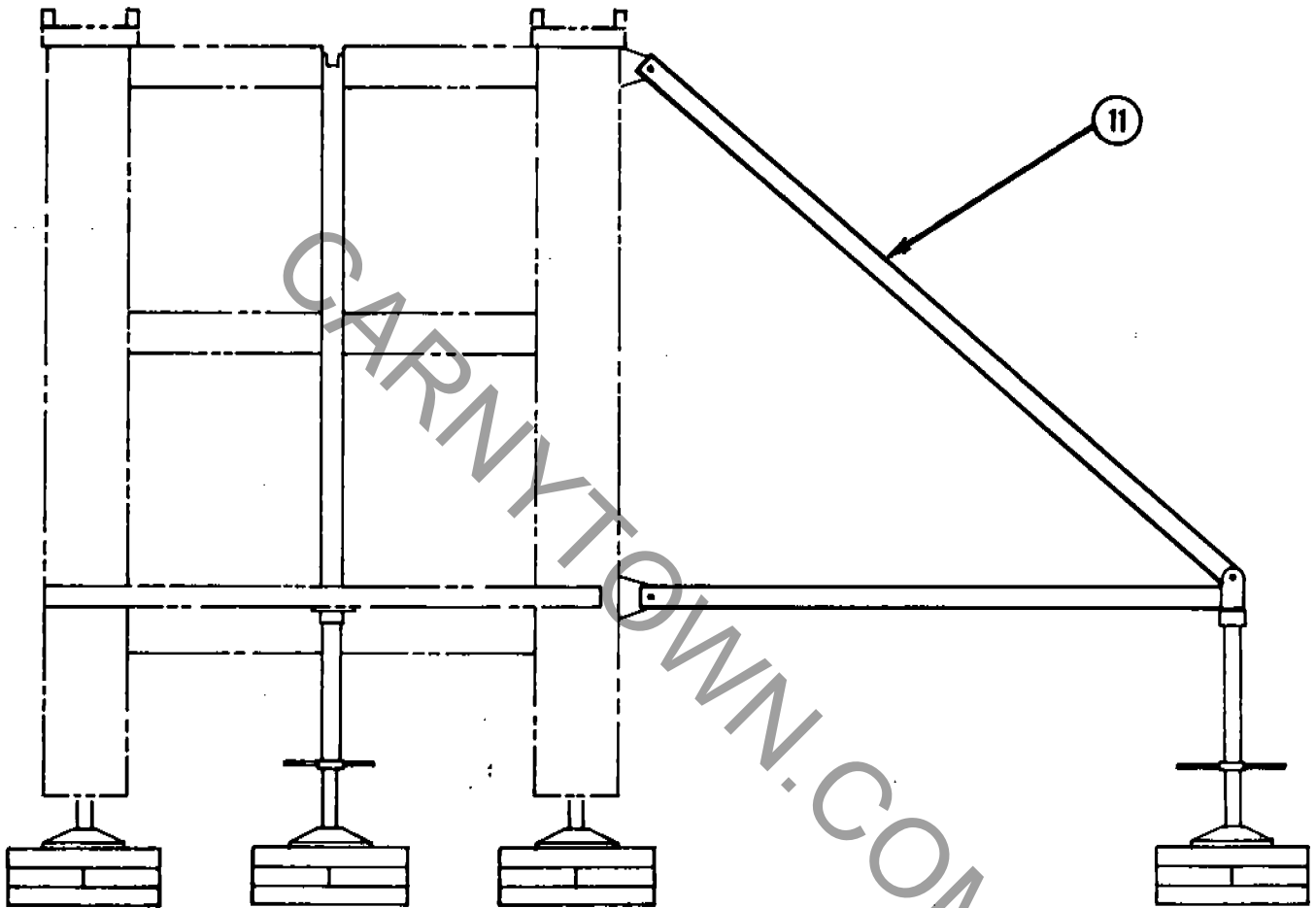

NEW STYLE

11. () Inspect pins and safety pins in wind braces.

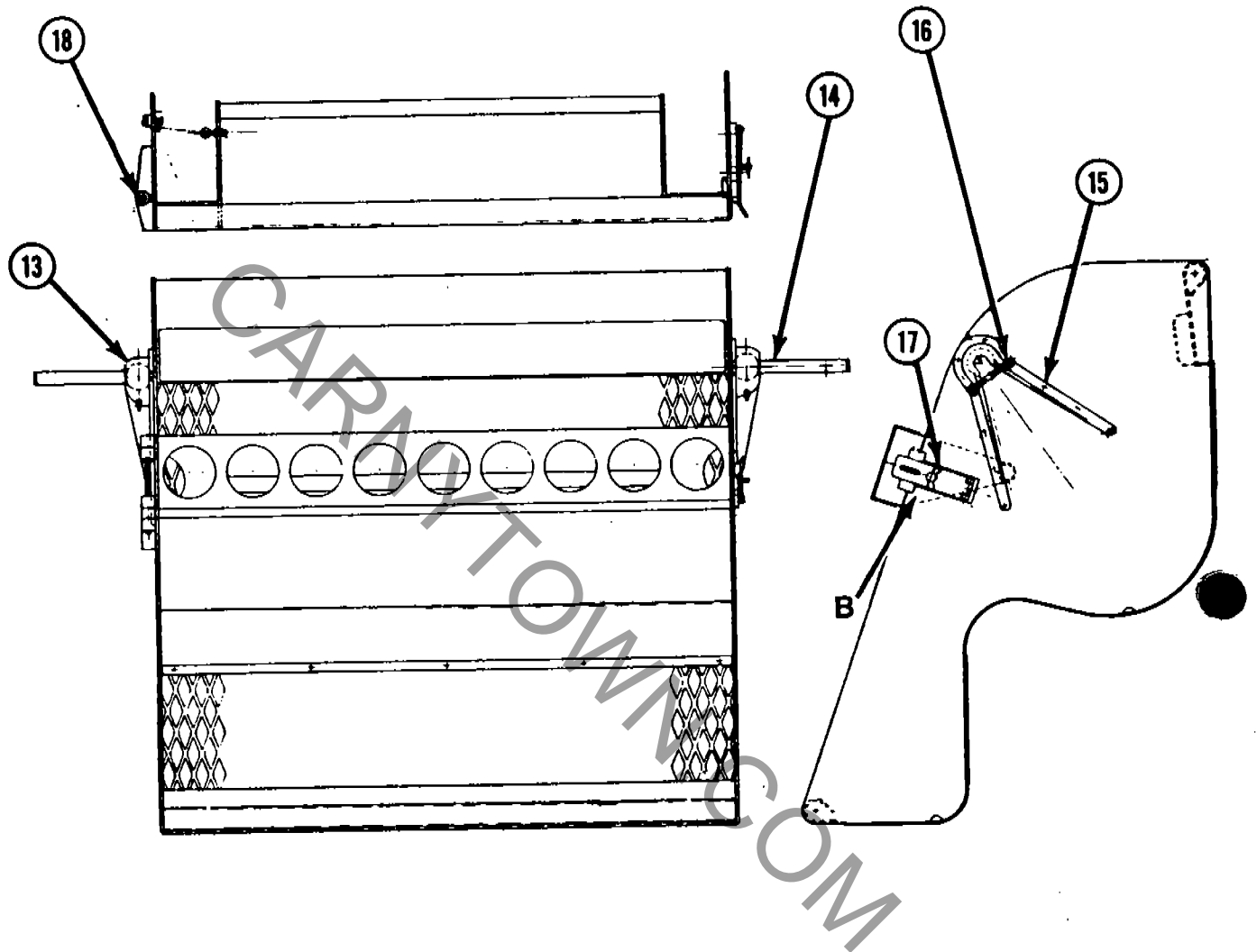

- 13. () Inspect rubber balls on sweep spindles. Measure the spread (Bulletin 99).
- 14. () Inspect seat spindles, snap rings and seat spindle bolts (Bulletins 99 and B47-0355-0).
- 15. () Inspect bolts in seat hinge castings.
- 16. () Inspect pin under seat spindle.
- 17. () Inspect seat latch and safety pins (Bulletin 96).
- 18. () Inspect keepers on lap bar hinge pin.

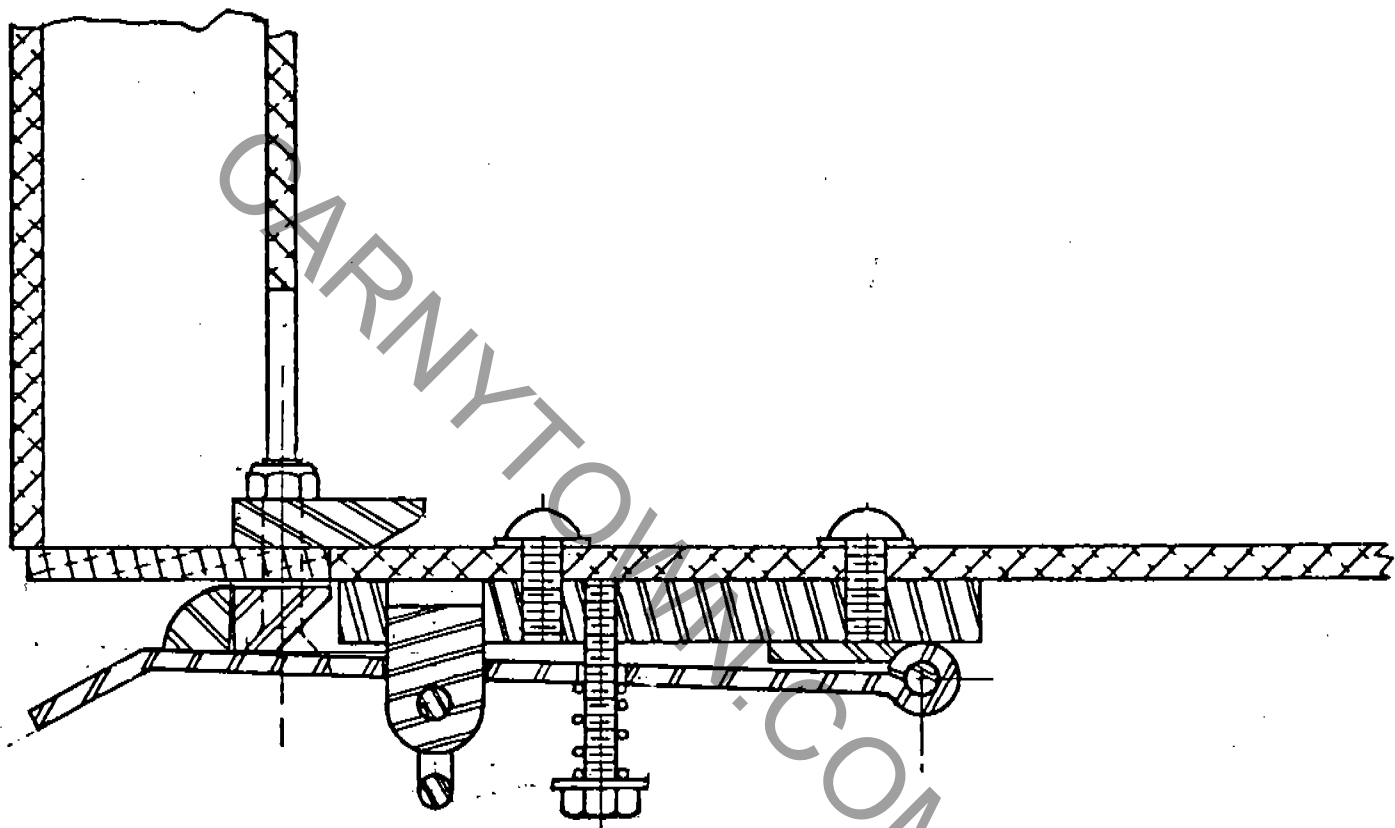

DETAL B

17. () Inspect seat latch and safety pins (Bulletin 96).

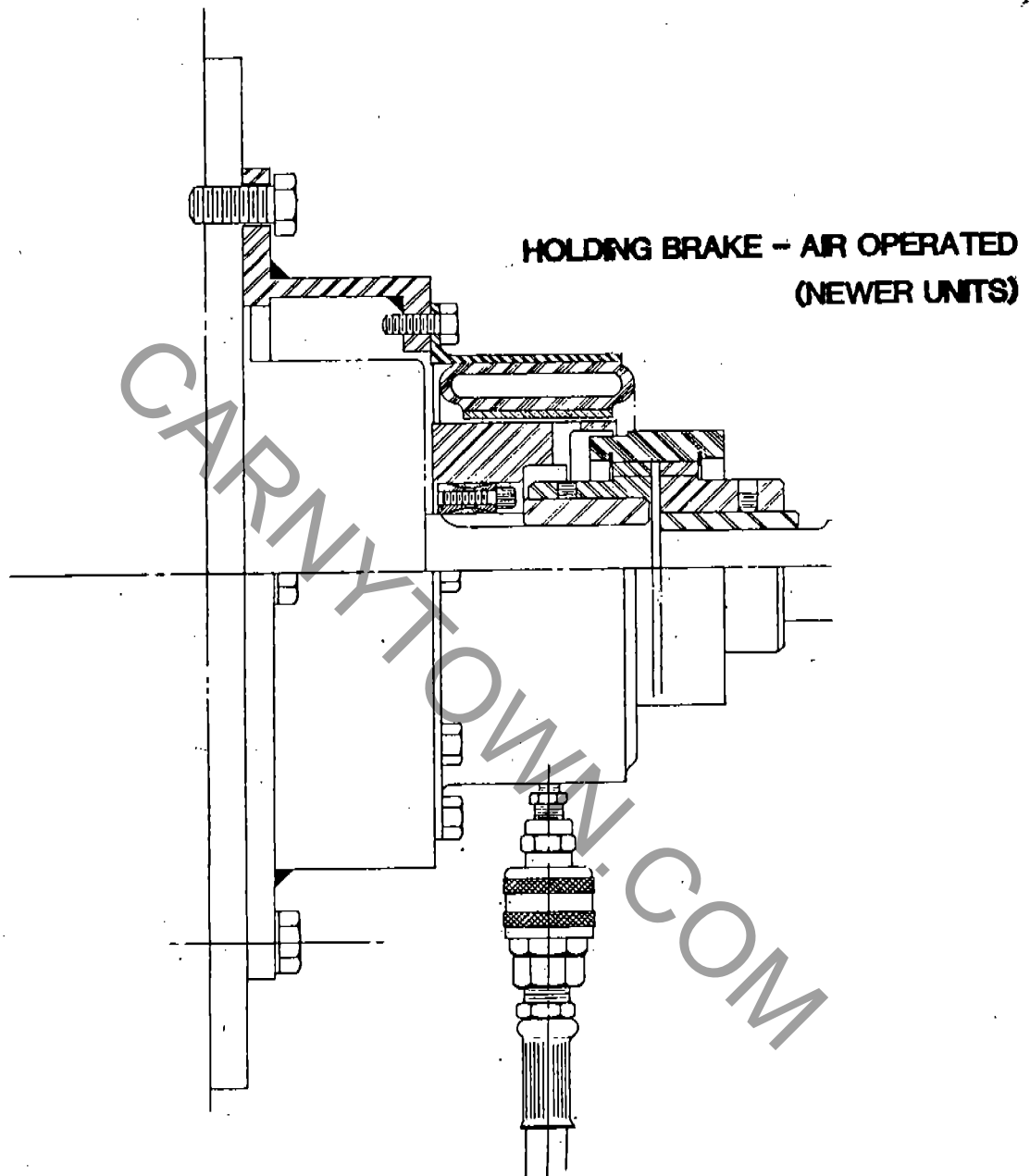

19. () Inspect holding brake.

**HOLDING BRAKE → AIR OPERATED
(NEWER UNITS)**

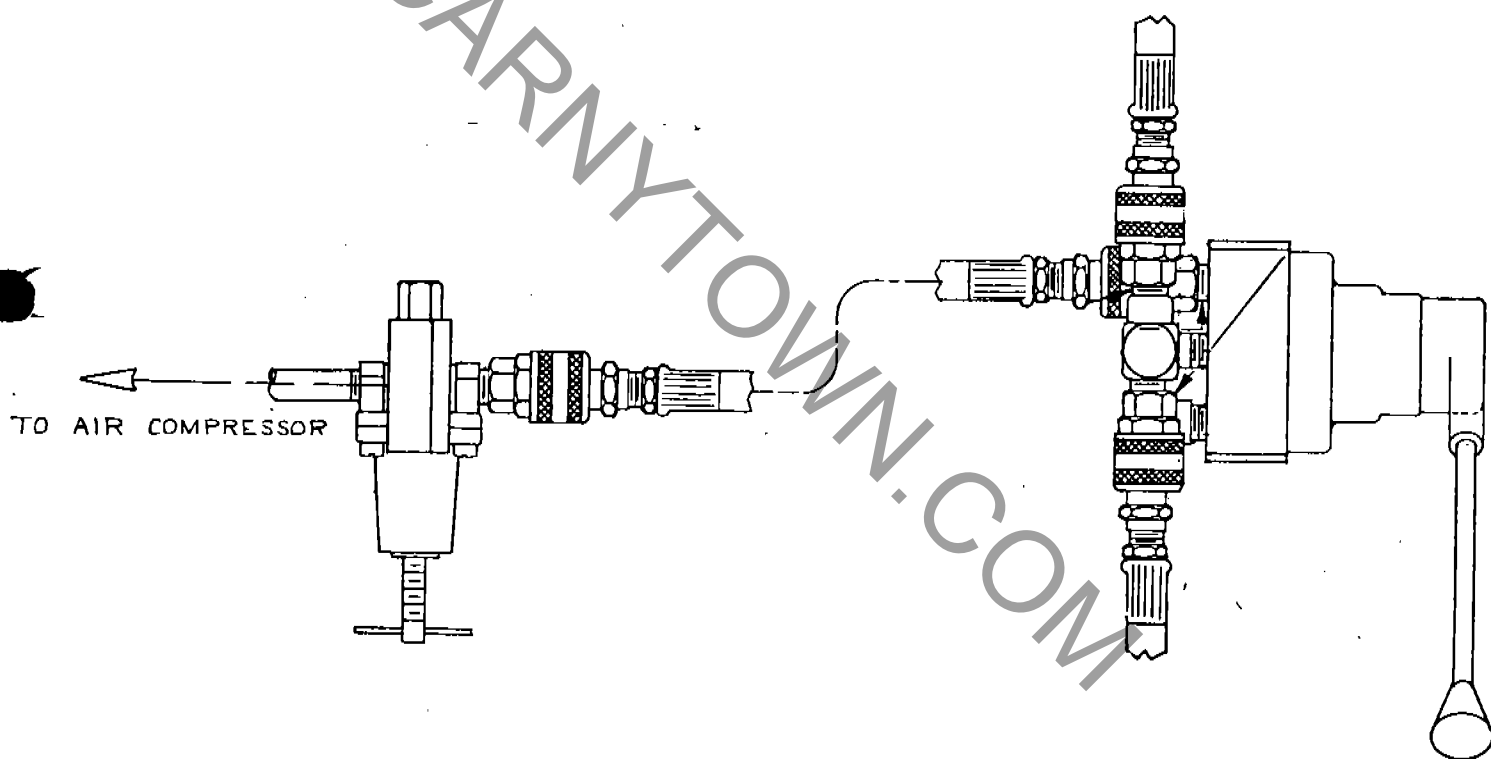

19. () Inspect holding brake.

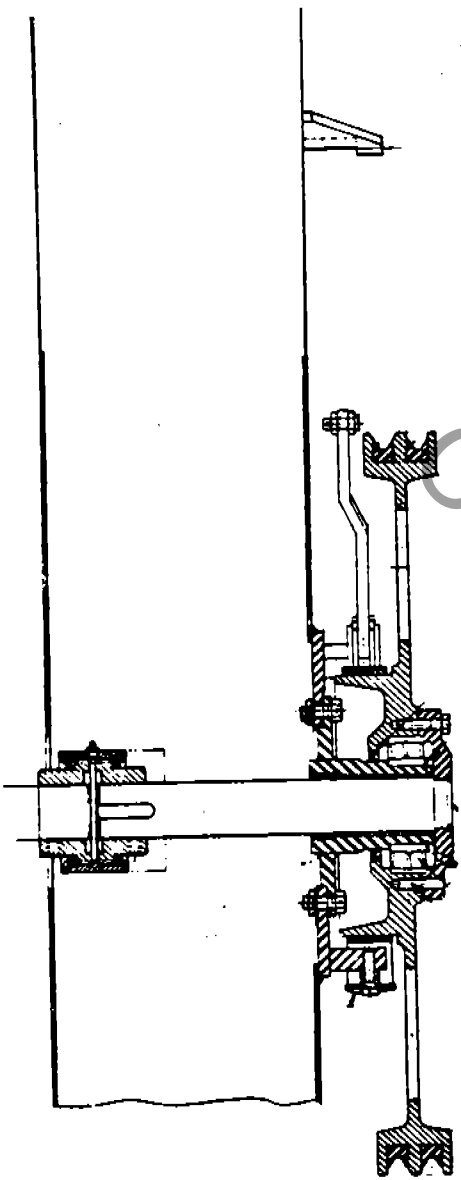

HOLDING BRAKE (OLDER UNITS)

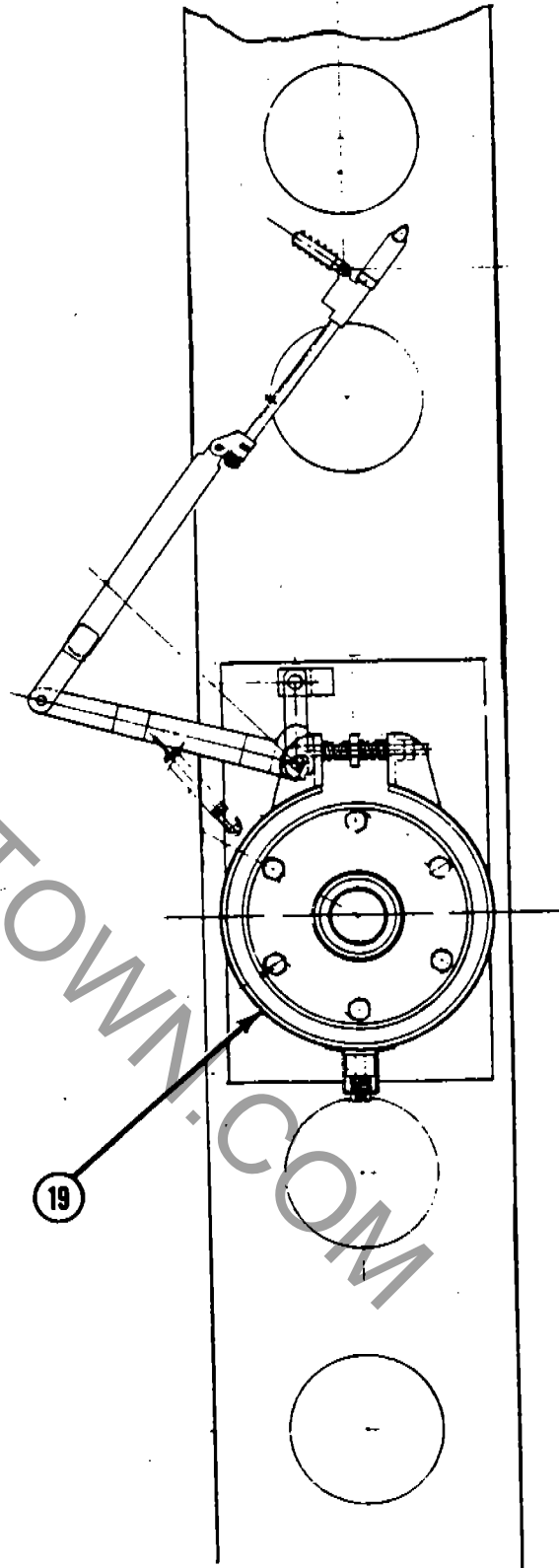

19. () Inspect holding brake.

OLD STYLE

Solid axle shaft
Units 71-2601 through 74-2609

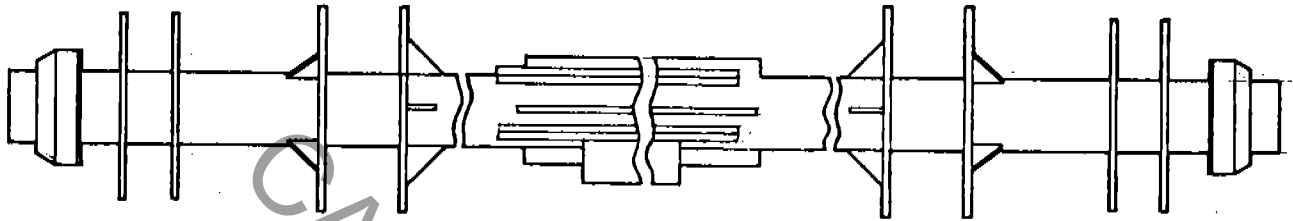

DO NOT ATTEMPT TO WELD ON SHAFT

NEW STYLE

Axle revolves around "dead" axle
Units 75-2610 and on

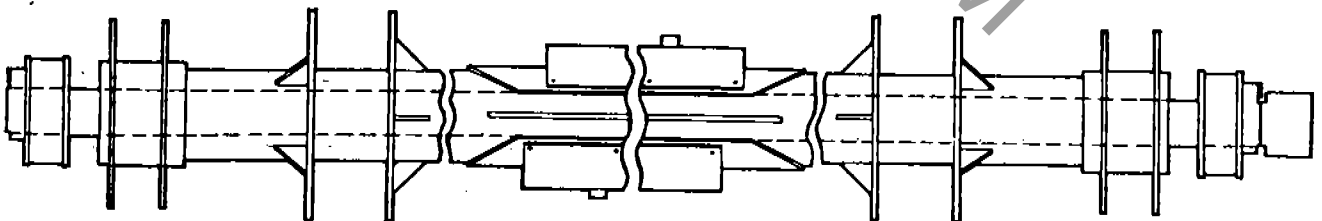

20. () Inspect boom axle for cracks (Bulletin B379R1041-0. See Bulletin 111 for old style boom axle).

NEW STYLE

Axle revolves around "dead" axle
Units 71-2601 through 74-2609

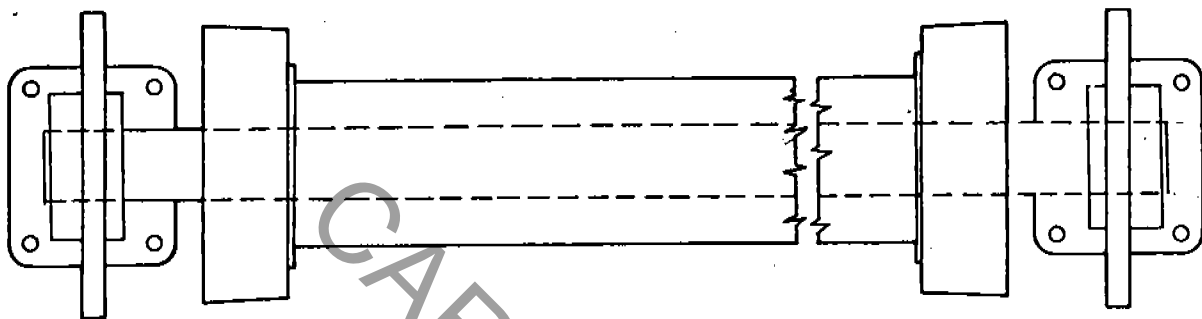

DO NOT ATTEMPT TO WELD ON SHAFT

OLD STYLE

Solid axle shaft
Units prior to 75-2610

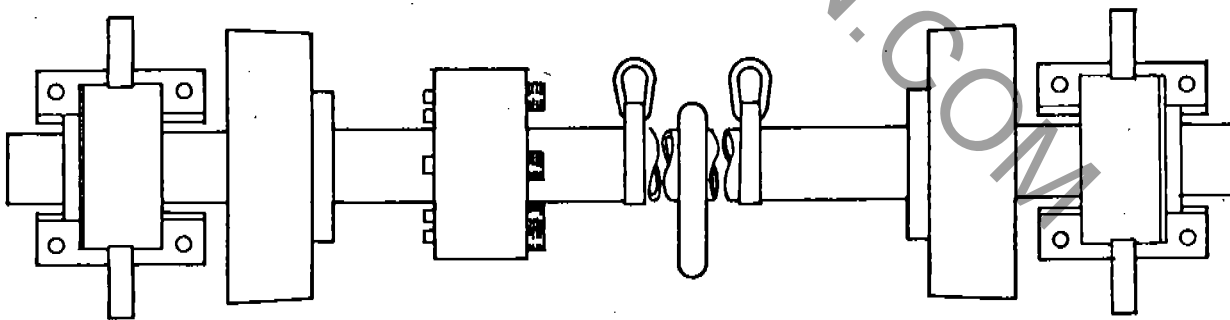

29. () Inspect wheel axles.



NUMBER: B379R1101-0

DATE: NOV. 1, 1991

SUPERSEDES:

America's Largest Manufacturer of Amusement Rides

SERVICE BULLETIN

Effective Serial Number: All Units - Chance Manufacturing Co., Inc.

Chance Rides, Inc. SPECIFICALLY DISCLAIMS ANY LIABILITY for losses associated with rides produced by Chance Manufacturing Company, Inc.

Ride: SKYWHEEL

Subject: Passenger Safety Decal

Chance Rides, Inc. has become aware that it is possible for a person with long hair to get it caught in the seat journal bolts causing injury. ALL OPERATORS MUST VERBALLY INSTRUCT PASSENGERS TO KEEP ALL ITEMS INCLUDING HAIR INSIDE SEAT AREA. A safety decal emphasizing this information has been developed.

Chance Rides, Inc. requires all owner/operators of SKYWHEEL amusement rides to order and install these safety decals. A total of 32 decals is required, two per seat. Order quantity required of part number 22198509 and install as shown on this bulletin.

All work must be performed by qualified personnel, capable of understanding the function of the parts and their proper installation.

NOTICE

Use only those components authorized, specified or provided by Chance Rides, Inc.

Chance Rides, Inc. SPECIFICALLY DISCLAIMS ANY LIABILITY for losses associated with any unauthorized alterations and/or modifications or additions and installations of unauthorized components.

CAUTION

ROTATING PARTS CAN
CAUSE PERSONAL INJURY.

SIT FACING FORWARD.
KEEP HANDS, ARMS, HEAD
AND HAIR INSIDE SEAT.

22198509

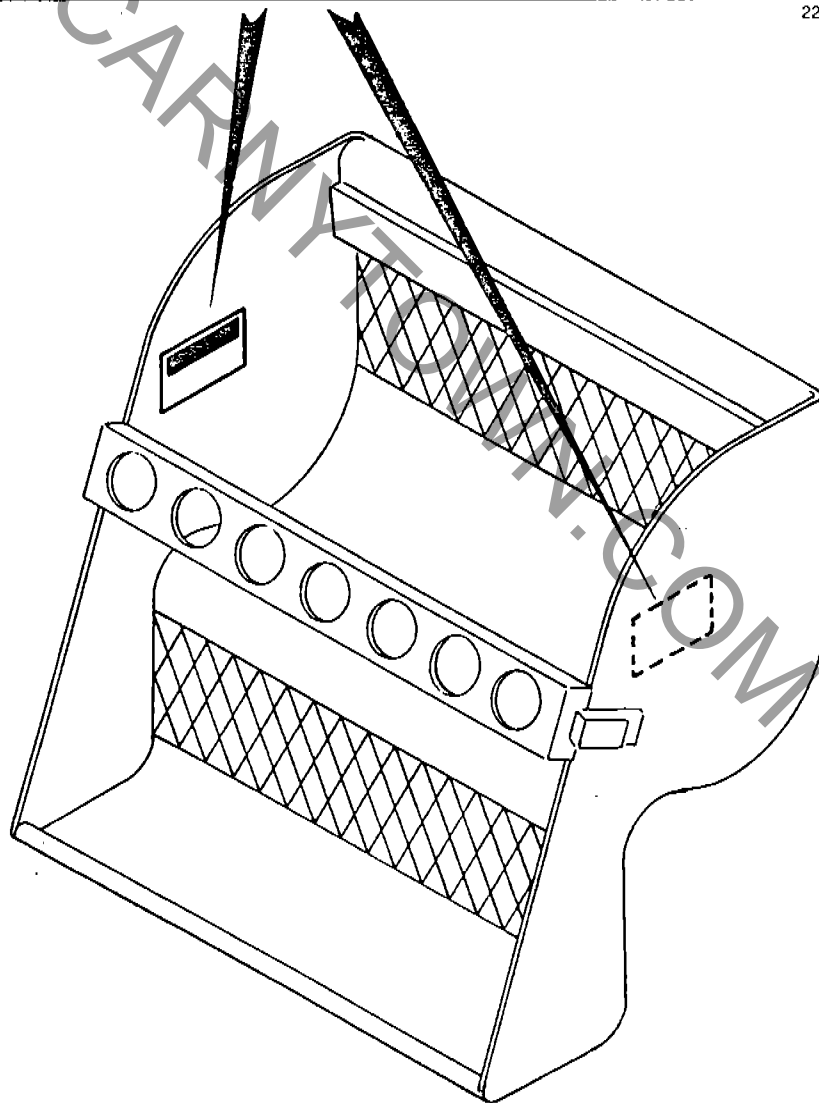

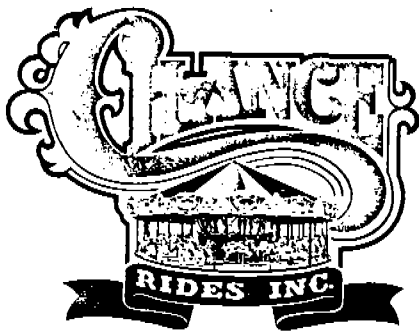

Number: B160R1063-0

Date: April 13, 1990

America's Largest Manufacturer of Amusement Rides

SERVICE BULLETIN

Effective Serial Number: All Units - Chance Manufacturing Co.

Chance Rides, Inc. SPECIFICALLY DISCLAIMS ANY LIABILITY for losses associated with rides produced by Chance Manufacturing Company, Inc.

Ride: SKYWHEEL Subject: Casting Installation

It has been found during field inspections by Chance Rides, Inc. personnel that some spoke castings on some SKYWHEEL amusement rides have been improperly installed. These castings were installed without the use of epoxy between the two halves. This results in a space between the two halves when clamped together around the spokes, as shown in illustration A. When the 5/16 inch bolts are brought to the proper torque the stress created on the casting due to this space may cause the casting to crack.

Whenever the castings on the spokes are removed or replaced the following proper installation procedure must be followed.

1. Thoroughly clean the area of the spoke where the casting will be mounted with lacquer thinner or a suitable solvent that removes all contaminants and which will not leave a residue.
2. Apply a good quality auto paste wax to each location on the spoke where a casting is to be positioned.
3. Mix the special epoxy and hardener per the instructions on the kit. Use kit number S0056100 only.
4. Apply the epoxy to the inside of both halves of the casting, to a uniform layer of approximately 1/4 inch thick.
5. Use a torque wrench to torque the 5/16 inch bolts to 5 to 7 foot pounds. After the epoxy has hardened for at least 3 hours, torque bolts to 10 to 12 foot pounds.

ILLUSTRATION A

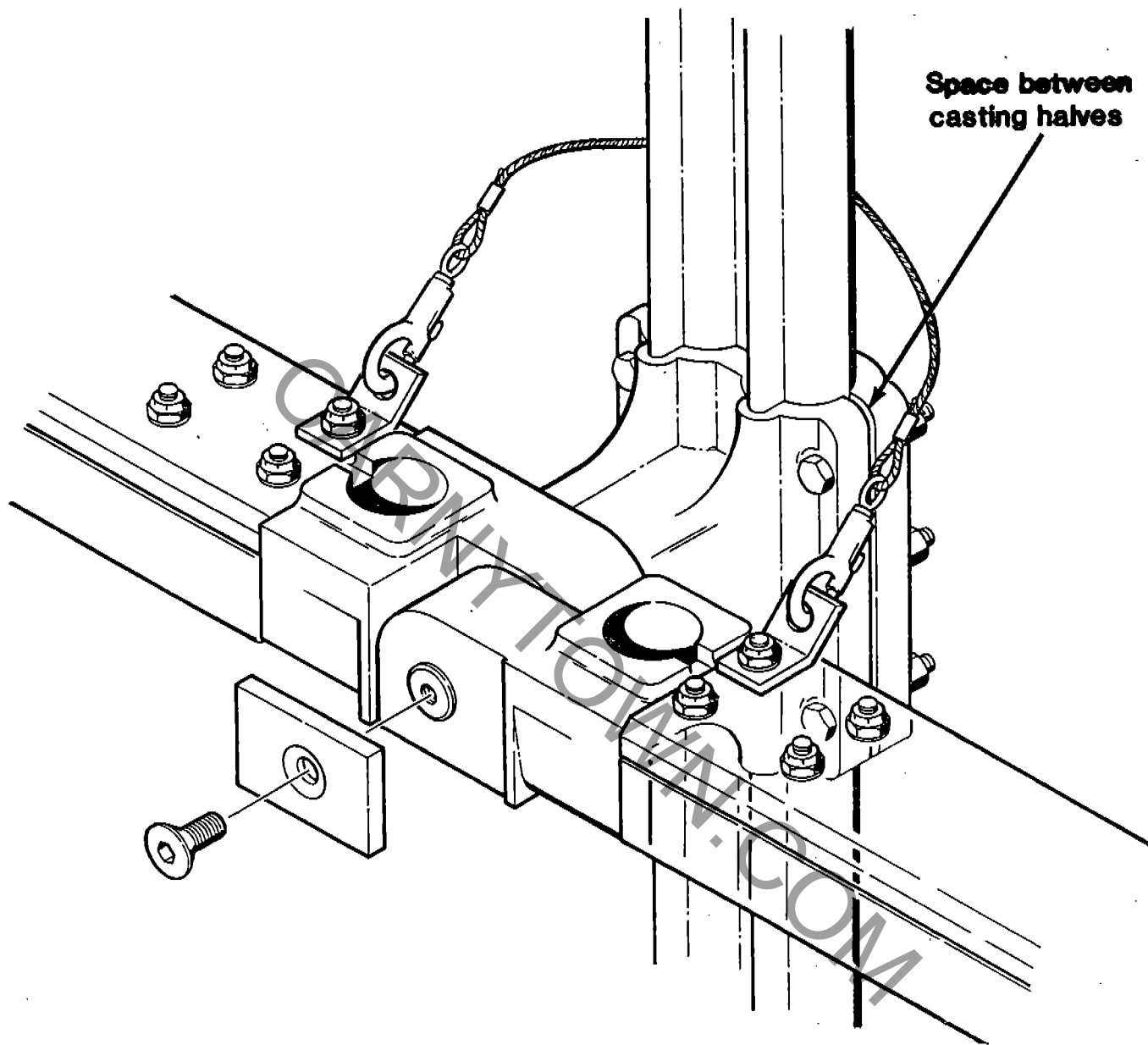

This bulletin applies to all spoke castings, including:

1. seat hanger support castings
2. rim iron support castings
3. spoke hub castings



Number: B160R1060-0

Date: March 16, 1990

America's Largest Manufacturer of Amusement Rides

SERVICE BULLETIN

Effective Serial Numbers: ALL UNITS - Chance Manufacturing Co. Inc.

Chance Rides, Inc. SPECIFICALLY DISCLAIMS ANY LIABILITY for losses associated with rides produced by Chance Manufacturing Company, Inc.

Ride: SKYWHEEL Subject: INSPECTION OF SPOKES

Chance Rides, Inc. has become aware of a SKYWHEEL amusement ride in which cracks developed in a spoke. All SKYWHEEL owners are required to perform the inspection on each spoke of their ride as described on the reverse side of this bulletin. The Certification Of Compliance must be filled in and returned to Chance Rides, Inc. within 15 days from receipt of this bulletin.

This inspection must be performed on an annual basis.

This inspection must be performed by qualified personnel, capable of understanding the function of the parts and their proper installation. If there are any questions regarding the instructions or this inspection, contact the Chance Customer Service Department.

NOTICE

USE ONLY THOSE COMPONENTS AUTHORIZED, SPECIFIED OR PROVIDED BY CHANCE RIDES, Inc.

CHANCE RIDES, INC. SPECIFICALLY DISCLAIMS ANY LIABILITY FOR LOSSES ASSOCIATED WITH ANY UNAUTHORIZED ALTERATIONS AND/OR MODIFICATIONS OR ADDITIONS AND INSTALLATIONS OF UNAUTHORIZED COMPONENTS.

INSPECTION PROCEDURES

1. Thoroughly clean all surfaces of each spoke. Using a suitable solvent, remove all dirt and grease residues.
2. Visually inspect entire length of spoke. Particular attention must be given to the areas around each casting, see example illustration below.
3. If visual inspection reveals a questionable area, that area must be inspected by a qualified person using liquid penetrant testing.
4. If any cracks are found, DO NOT ATTEMPT TO REPAIR OR WELD THEM, contact Chance Customer Service immediately. DO NOT OPERATE THE RIDE UNTIL CHANCE CUSTOMER SERVICE HAS BEEN NOTIFIED AND THE APPROVED REPAIR PROCEDURES COMPLETED.

RIM IRON SUPPORT ASSEMBLY

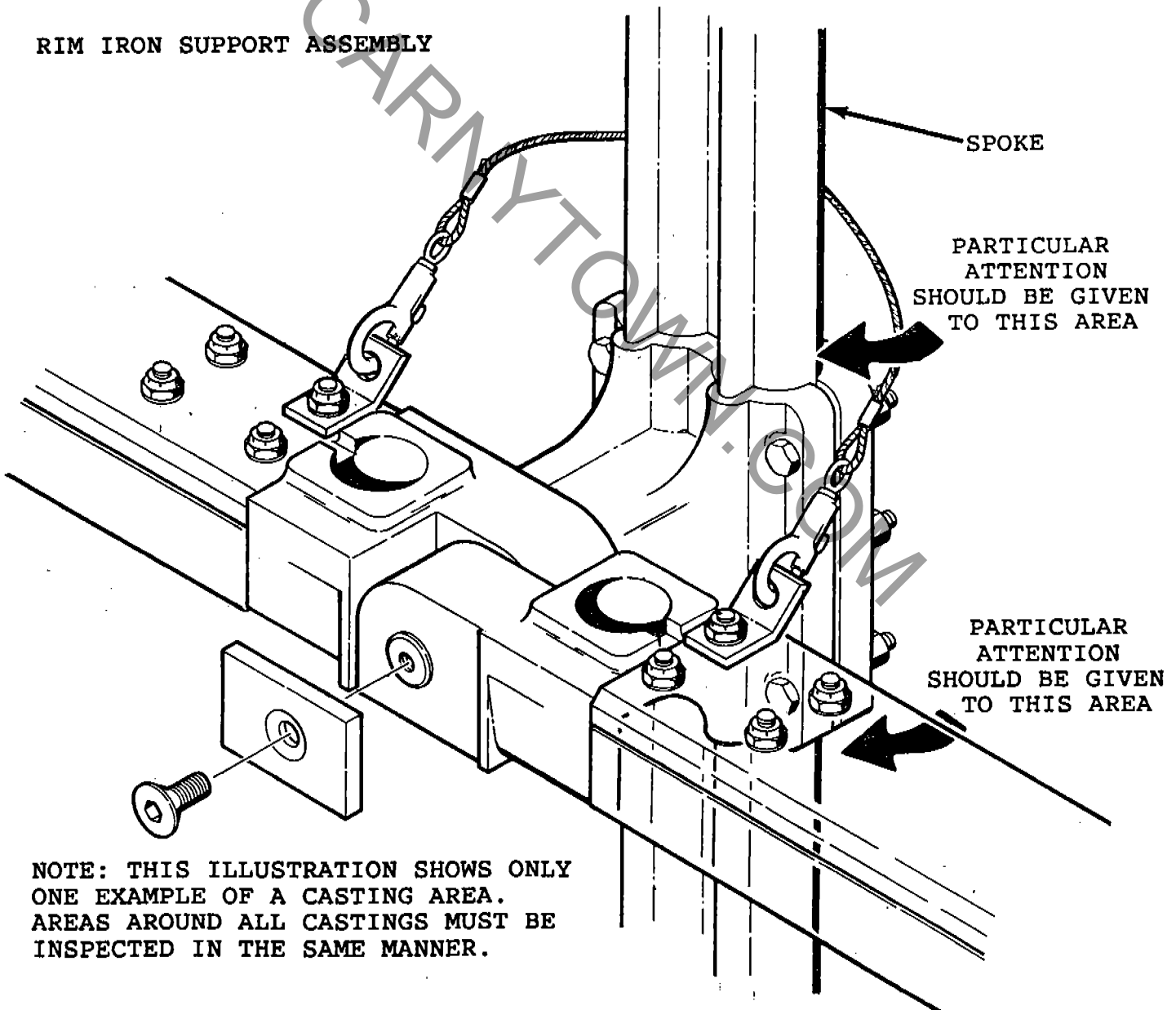



Number: B47-0357-00

Date: Feb. 1, 1990

Supersedes:

America's Largest Manufacturer of Amusement Rides

SERVICE BULLETIN

Effective Serial Numbers: All Units

Ride: SKY WHEEL

Subject: Drive Rim Segment Inspection
and Retainer Kit

It has come to the attention of Chance Manufacturing Co., Inc. that some problems may exist in the area where the rim irons on the SKY WHEEL amusement ride attaches to the spokes. To help restore these rides to their original safe condition the following items must be done:

1. The threads on the inside of the drive rim segment mounting pins must be cleaned using a 3/8" tap, to a depth of one inch.
2. The mounting of the rim segments must be done to manufacturer's specifications as shown in Illustration A and B.

IMPORTANT

No rubber O-Rings or gromets are used when mounting rim segments. No plate should be used between the spoke casting and the rim segments. Inspect and replace bushing if necessary.

ILLUSTRATION A

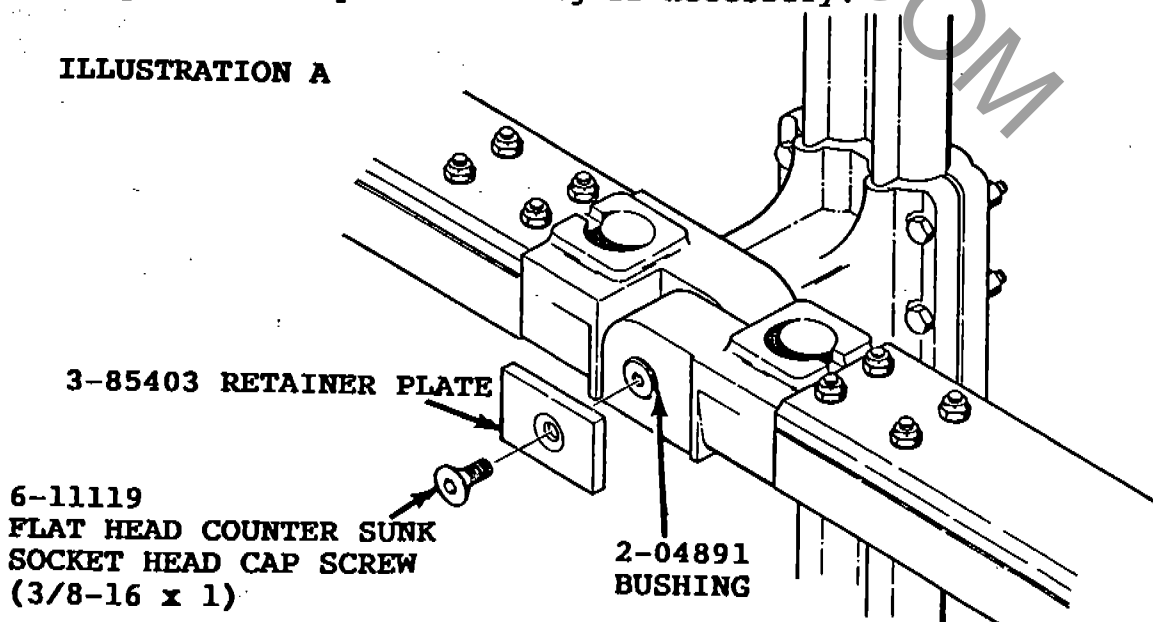

Factory and Sales Office: 4219 Irving • P.O. Box 12328 • Wichita, Kansas 67277 • (316) 942-7411

ILLUSTRATION B

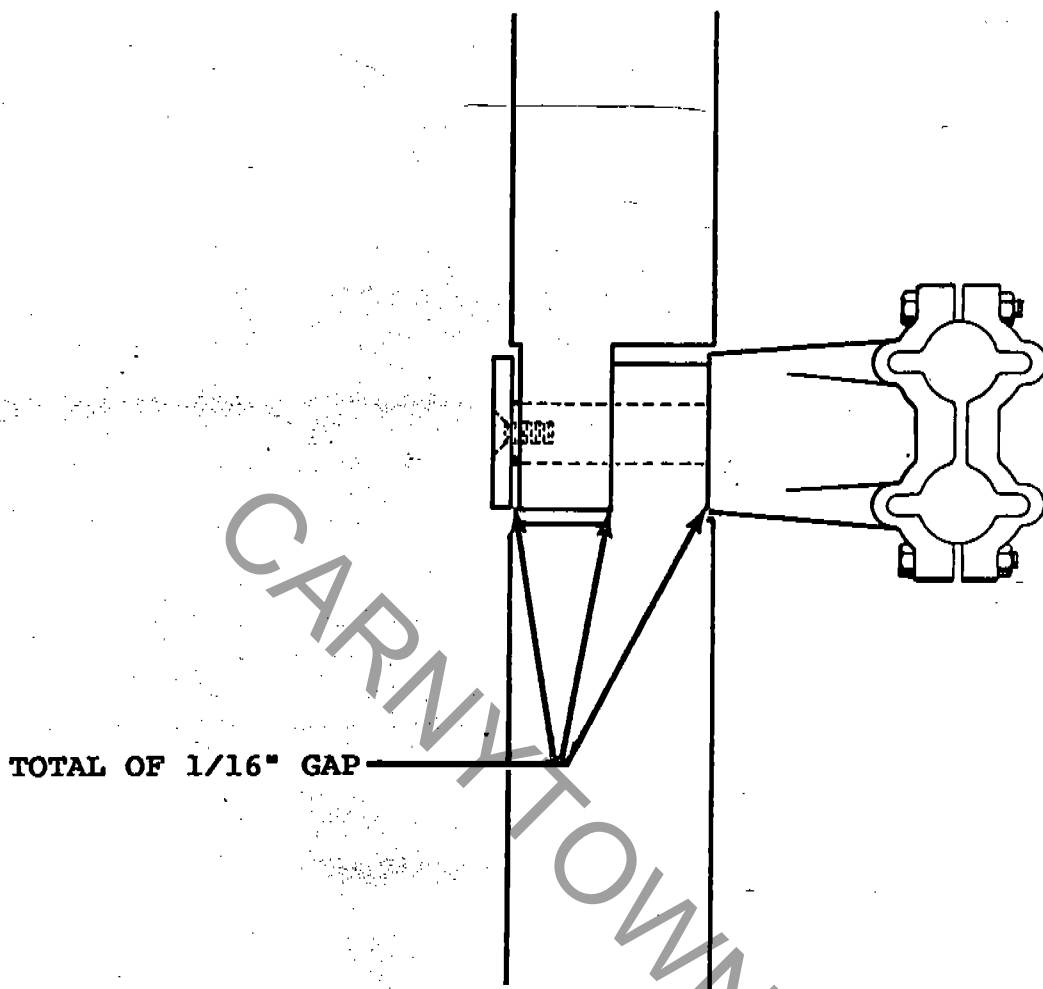

As an additional safety to these rides a new kit is now available. This kit when installed would prevent the rim irons from coming off the mounting pins in the event that the mounting bolt would back out or break. Chance Manufacturing requires that all SKY WHEEL owners install kit number K47-0357-00. Perform the rework using the installation instructions on the reverse side of this bulletin and the parts provided. Return the attached Certification of Compliance within fifteen (15) days from receipt of the kit.

RIM IRON RETAINER KIT

<u>Item No.</u>	<u>Part No.</u>	<u>Description</u>	<u>Quantity Required</u>
1	61091901	3/8-16 x 3-1/4" Flat CSK S.H. Screw	64
2	31674300	Retaining Clip	64
3	68531000	3/8" I.D. Flat Washer	64
4	64804600	3/8-16 Flex Locknut	64
5	21106900	Cable Retainer Assy.	32

INSTALLATION INSTRUCTIONS

1. Remove one of the 3/8-16 x 3" flat head counter sunk socket screws from each end of the rim iron as shown in Illustration C.
2. Put in new 3/8-16 x 3-1/4" flat head counter sunk socket screw (item 1).
3. Place retaining clip (item 2) over screw, then flat washer (item 3) and secure with lock nut (item 4) and 16 foot pounds with a torque wrench.
4. Cable retainer assembly is snapped from one retaining clip to the other as shown in Illustration C.

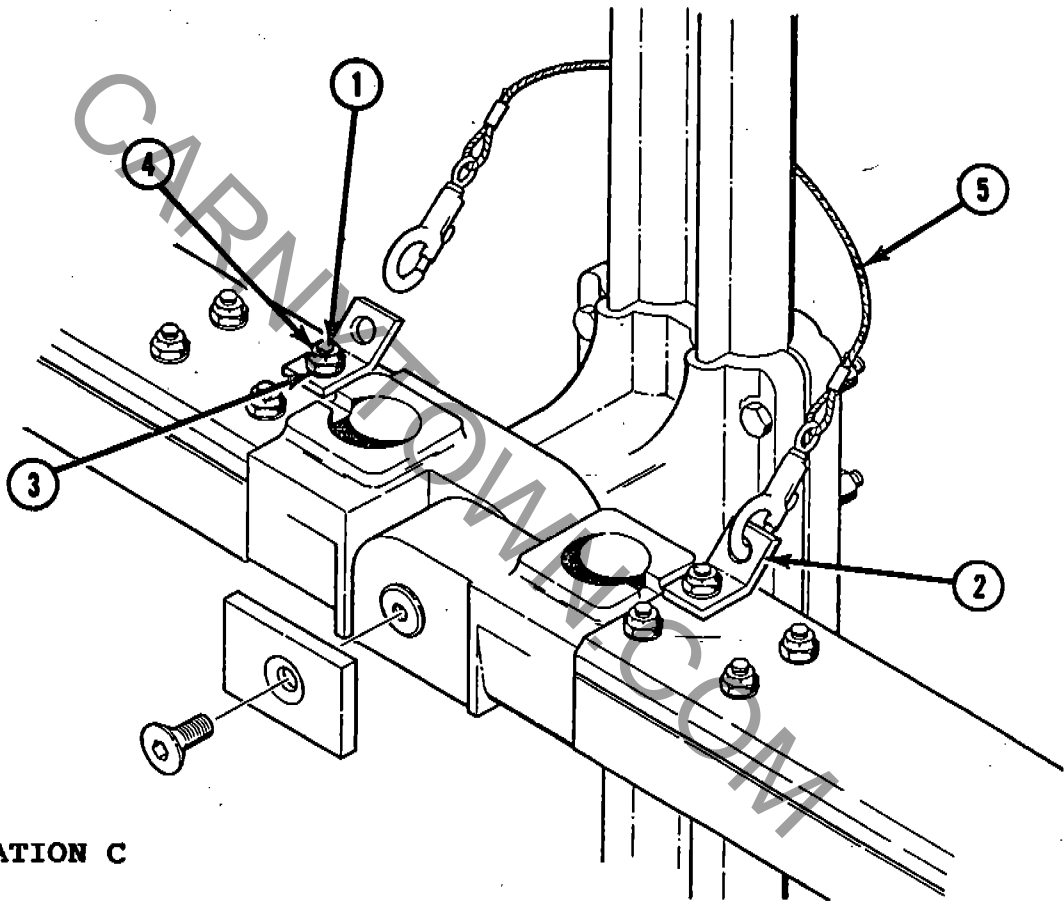

ILLUSTRATION C

NOTICE

All work must be performed by qualified personnel, capable of understanding the function of the parts and their proper installation.

Use only those components authorized, specified or provided by the manufacturer. If any alterations and/or modifications or additions and installations of unauthorized components are made to the original design without the manufacturer's explicit written consent or without direct supervision by a manufacturer's representative, Chance Manufacturing Co., Inc. makes no claim as to the integrity of the altered or modified ride.

CARNYTOWN.COM



Number: B47-0355-00

Date: Feb. 1, 1990

Supersedes:

America's Largest Manufacturer of Amusement Rides

SERVICE BULLETIN

Effective Serial Numbers: All Units

Ride: SKY WHEEL

Subject: Seat Spindle Bolt
Identification

It has come to Chance Manufacturing's attention that the Bowmalok® self locking capscrew used with the seat spindle shaft for SKY WHEEL amusement ride as illustrated below is no longer available.

SEAT SPINDLE SHAFT
3-64881

HARDENED WASHER 2-85508

SELF-LOCKING
CAPSCREW
3-12510

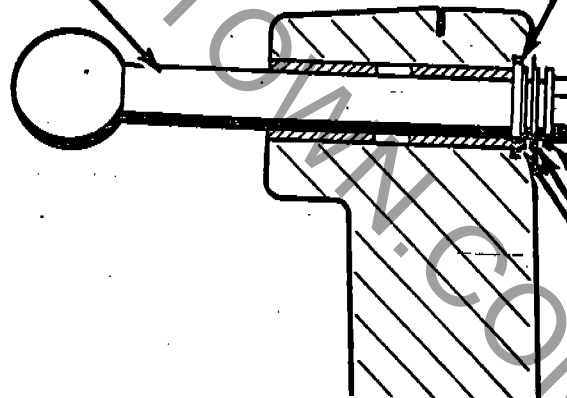

WASHER 6-85316

SNAP RING 2-61086

A new self locking capscrew is now available and must be used when replacing the old style self locking capscrew. Only self-locking capscrews as identified below are acceptable for use with the seat shaft spindle.

Numbers may vary due to production date

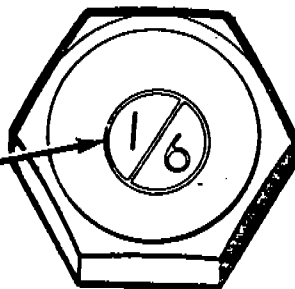

NEW STYLE
Part No. 3-12510

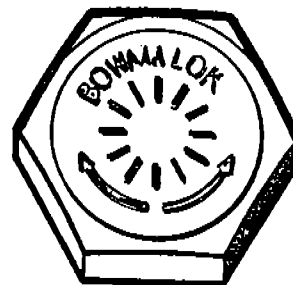

OLD STYLE

Factory and Sales Office: 4219 Irving • P.O. Box 12328 • Wichita, Kansas 67277 • (316) 942-7411

IMPORTANT

IF EITHER OF THESE SELF LOCKING CAPSCREWS IS REMOVED FROM THE SEAT SHAFT SPINDLE FOR ANY REASON, IT MUST BE DISCARDED AND A NEW SELF LOCKING CAPSCREW USED IN ITS PLACE.

All work must be performed by competent, qualified mechanics, capable of understanding the function of the parts and their proper installation. If there are any questions regarding the instructions of this bulletin, contact the Chance Customer Service Department.

NOTICE

Use only those components authorized, specified or provided by the manufacturer. If any alterations and/or modifications or additions and installations of unauthorized components are made to the original design without the manufacturer's explicit written consent or without direct supervision by a manufacturer's representative, Chance Manufacturing Co., Inc. makes no claims to the integrity of the altered or modified ride.



Number: B379R1041-0

Date: July 17, 1989

Supersedes:

America's Largest Manufacturer of Amusement Rides

SERVICE BULLETIN

Effective Serial Numbers: All Units

Model: SKY WHEEL

Subject: Boom Axle Inspection

In 1987, CHANCE RIDES, INC. made available a newly designed boom axle for the SKY WHEEL. This new axle has segmented components which are shrink-fit to a single axle tube, thus eliminating welding directly to the tube, and resulting in a more fatigue-resistant axle.

The boom axle is an important structural component of the SKY WHEEL. As a safety precaution, it must be inspected regularly. If the boom axle fails during operation, serious structural damage and possible injury to passengers and/or bystanders can result.

All owners of SKY WHEEL amusement rides which are equipped with the new style boom axle are required to inspect the boom axle as described in this bulletin. These axles can be identified as shown below.

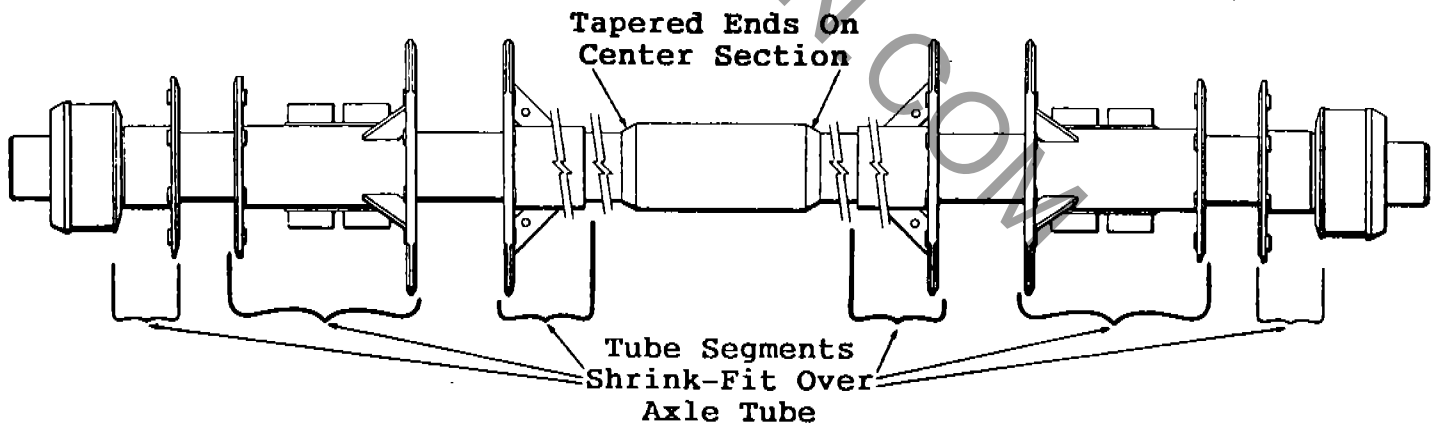

Perform the inspection as described on the reverse side of this bulletin. Fill out and return the attached Certificate Of Compliance for the inspection no later than February 1, 1990.

NOTE: Complete the Certificate Of Compliance only for the initial NDT inspection. Visual inspections must commence immediately.

If there are any questions regarding this inspection, contact the CHANCE CUSTOMER SERVICE DEPARTMENT immediately.

INSPECTION PROCEDURE

Visual inspection of the ride's major structural components must be made on a continuing basis. The following inspection of the boom axle must be made in addition to the ongoing inspection of the ride.

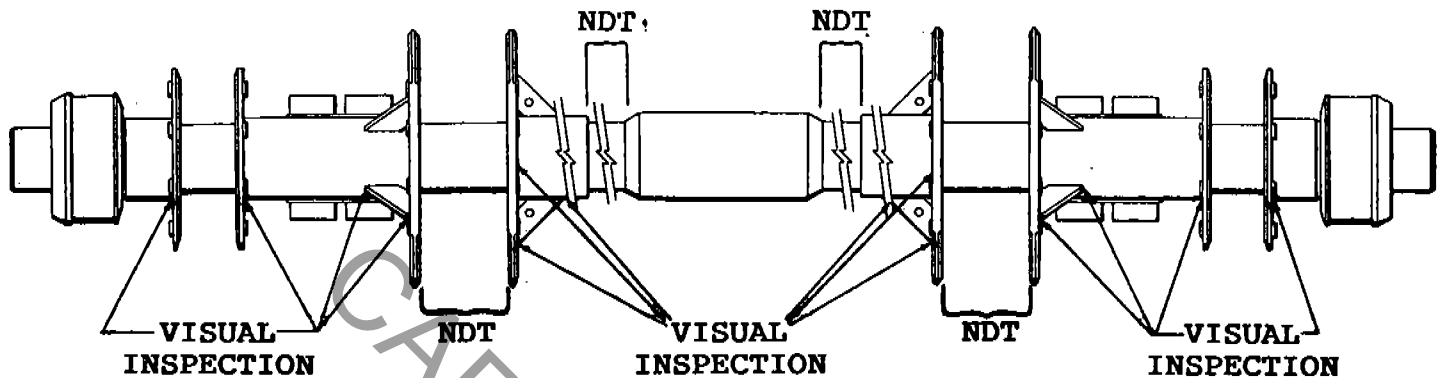

- ANNUALLY - At least once each operating season, the axle must be checked by a certified testing firm, using a suitable non-destructive testing (NDT) method in the areas noted.
- MONTHLY - Visually check the axle as noted once a month, or at every set-up, whichever occurs first. Inspect the welds and the parent metal surrounding the welds. This inspection must be performed by qualified personnel, capable of understanding the function of the parts and their proper installation.

If cracks or any unusual condition are detected, contact the CHANCE CUSTOMER SERVICE DEPARTMENT immediately. DO NOT OPERATE THE RIDE.



Number: 111
Date: 1-5-76

Supersedes:

America's Largest Manufacturer of Amusement Rides

SERVICE BULLETIN

Effective Serial Numbers: 71-2601 through 74-2609
Ride: SKY WHEELS (CHANCE BUILT) Subject: BULL WHEEL AXLE CHECK

A SKY WHEEL built by the Allan Herschell Company had a Bull Wheel Axle fracture in two. Fortunately the ride did not collapse and no one was injured. However, the results of an accident such as this could be tragic.

The fracture occurred on an eight year old ride, and it is our opinion that the fracture was caused by the welding procedures that were used on the axle.

Newer axles have additional gussets, and strengthening members, but they were welded to Allan Herschell specifications. We feel these specifications are marginal from a safety standpoint.

Boom Axle Inspection

Because of the welding procedures used, it is imperative that all axles be checked by a certified testing firm. The axles can be checked by magna-flux, ultrasonic or other method deemed suitable by the testing firm, along the entire length of the axle, and especially in the welded areas.

All axles should be checked before the next operating season and once a year thereafter.

Visual Inspections

In addition, the ride operator should visually inspect structural members, including axles, daily before operating ride.

Failures of this type do not happen all of a sudden. The first signs of fatigue will be a hairline crack which enlarges until final failure occurs.

If any flaws or cracks are detected, contact the factory at once.

DO NOT ATTEMPT TO REWELD THE SHAFT

CARNYTOWN.COM



Number: 99
Date: 4-7-75

Supersedes:

America's Largest Manufacturer of Amusement Rides

SERVICE BULLETIN

Effective Serial Numbers **ALL UNITS BUILT PREVIOUS TO 4-3-75**

Ride: **SKY WHEEL**

Subject: **SEAT SUPPORT SHAFT MODIFICATION AND SPOKE CHECK**

As an added measure of safety on new SKY WHEELS, a bolt has been added to the end of the Seat Support Shaft.

Addition of the bolt was deemed necessary to insure that a seat would not be dropped because of a Seat Support Shaft coming out of the Spoke.

The previous method of double Snap Rings has proven adequate over the years. However, as the rides age and the spokes are handled more, there is an increasing possibility of the spokes spreading outward at the seat attach area. Should this happen, the Snap Rings will be subject to a shear type load, much greater than designed for.

The above condition should never happen, providing the spokes are handled in a reasonable fashion and periodically checked for a spreading condition.

It is recommended that all existing rides be modified and checked per the following instructions.

SPOKE CHECK

Spokes should be visually checked each time the ride is assembled.

Sight along each side of the spoke for signs of bending or twisting and measure between the ends.

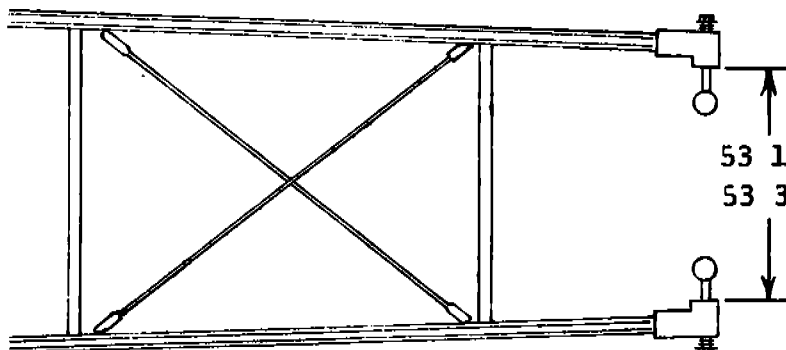

Sight along top side of each spoke

53 1/2" to
53 3/4"*

*54" to 54 1/4" on
Serial No's.
2664 & 2665 only

SPOKES NOT WITHIN LIMITS

If Spokes are bent and do not meet specified dimensions, consult Chance Manufacturing Company about corrective action.

Factory and Sales Office: 4219 Irving • P.O. Box 12328 • Wichita, Kansas 67277 • (316) 942-7411

**ADDITION OF BOLT TO SEAT
SUPPORT SHAFT**

Remove shafts from ride and modify per drawing.

New shafts can be ordered if modification of existing shafts is not practical.

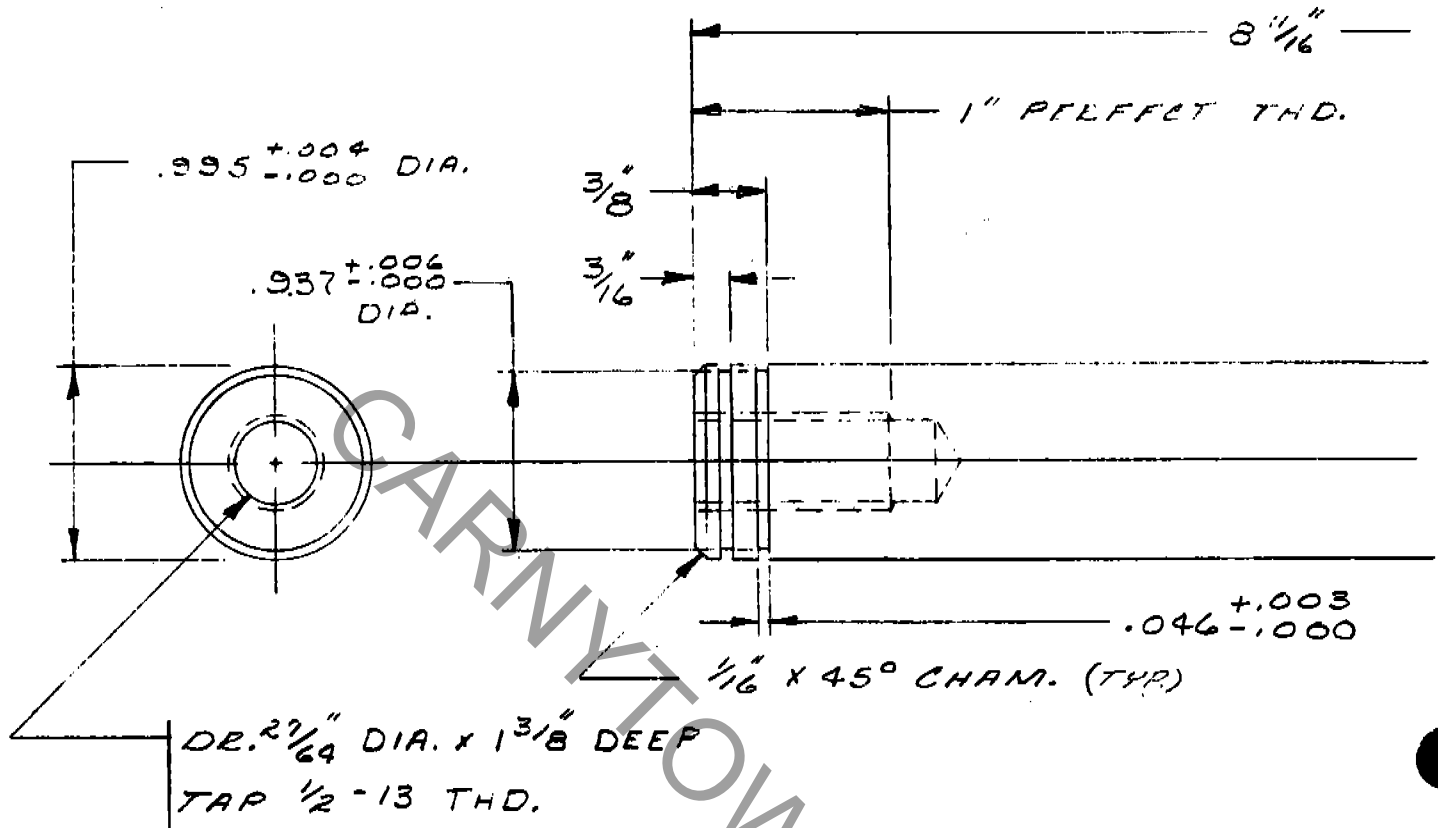

Installation

When installing new or reworked parts, use both of the Snap Rings and the special Self-Locking Bolt.

If old shafts have been reworked, the bolts can be ordered from us, Part Number 247-64329, or from Bowman Products Division, Part Number 41024.

New Shafts, Part Number 247-64881, will be shipped with Lock Bolt, Part Number 247-64329, and Washer.

Present cost of new shafts is \$11.40.

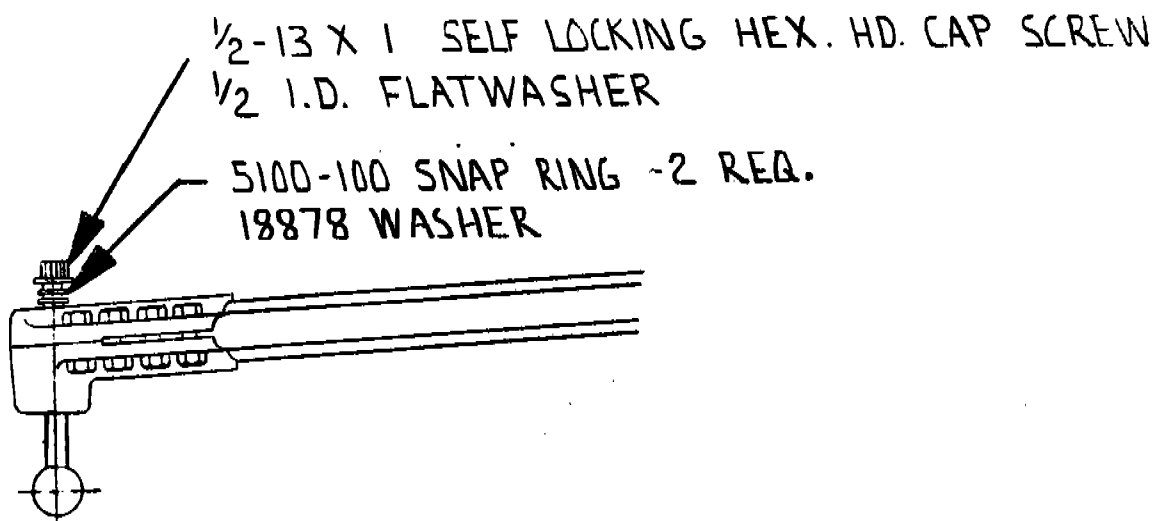



Number: 96
Date: 3-13-75

Supersedes:

America's Largest Manufacturer of Amusement Rides

SERVICE BULLETIN

Effective Serial Numbers:

Ride: ALL SKY WHEELS BUILT Subject: NEW STYLE SEAT LATCH
PREVIOUS TO MARCH, 1975

The Seat Latch for the SKY WHEEL has been redesigned to allow for the addition of a Hairpin Safety.

The addition of the Hairpin was deemed necessary as a safety precaution.

Cost of the new Seat Latches is \$23.00 at present. This represents a small investment for the protection it adds to your operation.

Installation of the latches is simple and can be accomplished in a short time. The only modification necessary is drilling a new hole in the seat.

NEW PARTS

QUANTITY PER SEAT	PART NUMBER	DESCRIPTION
1	347-39632	Latch Assembly
2	5/16-18 x 3/4	Soc. Hd. Button Cap Screw
2	5/16	Lock Washers

Factory and Sales Office: 4219 Irving • P.O. Box 12328 • Wichita, Kansas 67277 • (316) 942-7411

INSTALLATION

After removing old latches, position new Latch by installing screw (finger tight) in the hinge end of the latch.

Mark location of new hole and drill $5/16$ " dia. hole through seat.

Install second screw and torque both to 10-12 ft. lbs.

Check alignment and closure of Latch.

Shim the Latch Striker out from the Lap Bar if necessary to insure a good contact.

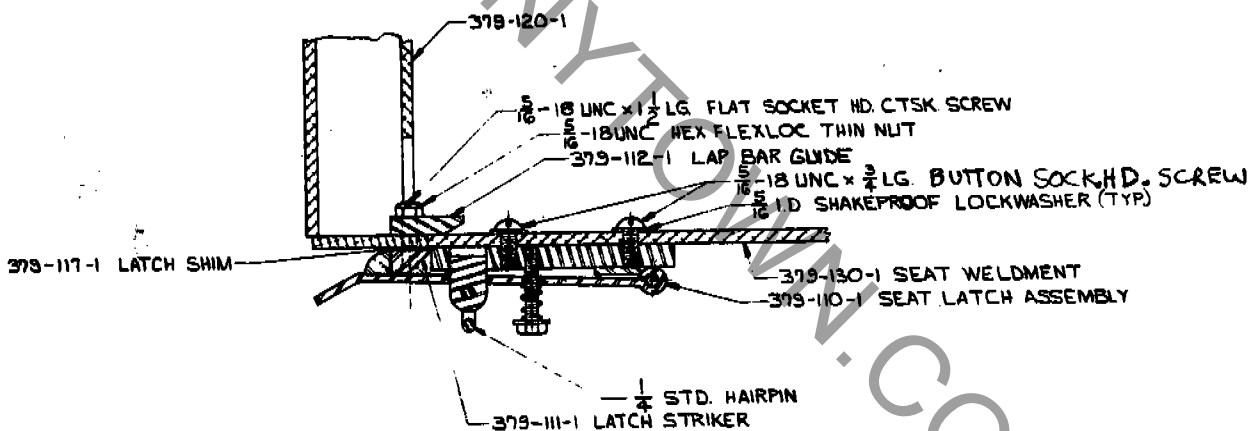



NUMBER: B379R1130-0

DATE: MAY 31, 1993

SUPERSEDES:

America's Largest Manufacturer of Amusement Rides

SERVICE BULLETIN

Effective Serial Number: All Units - Chance Manufacturing Co., Inc.

Chance Rides, Inc. SPECIFICALLY DISCLAIMS ANY LIABILITY for losses associated with rides produced by Chance Manufacturing Company, Inc.

Ride: SKYWHEEL Subject: Worm Gear Inspection

The design of the SKYWHEEL amusement ride utilizes a worm gear and shaft for raising and lowering the tower legs. The manufacturer of these parts requires periodic checks of the parts and specifies wear tolerances. Chance Rides, Inc. would like to reiterate the need for all owner/operators of the above noted rides to follow these inspection guidelines as stated in the vendor literature found in the owner's manual.

Chance Rides, Inc. believes "periodic checks" refers to the number of checks in a given period of time, based on the frequency of use. With the most infrequent of use, a minimum of an annual check may be considered periodic. As usage increases, however, more checks would be necessary.

In order to thoroughly inspect the worm gear, shaft, and jack screw these items must be completely disassembled and cleaned. The external and internal threads of the worm gear must not exceed the manufacturer's specifications for backlash. Backlash in excess of 50% of the threads thickness requires replacement of the worm gear.

All work must be performed by qualified personnel, capable of understanding the function of the parts and their proper installation.

NOTICE

Use only those components authorized, specified or provided by Chance Rides, Inc.

Chance Rides, Inc. SPECIFICALLY DISCLAIMS ANY LIABILITY for losses associated with any unauthorized alterations and/or modifications or additions and installations of unauthorized components.

SCREW JACK

WORM GEAR

SHAFT

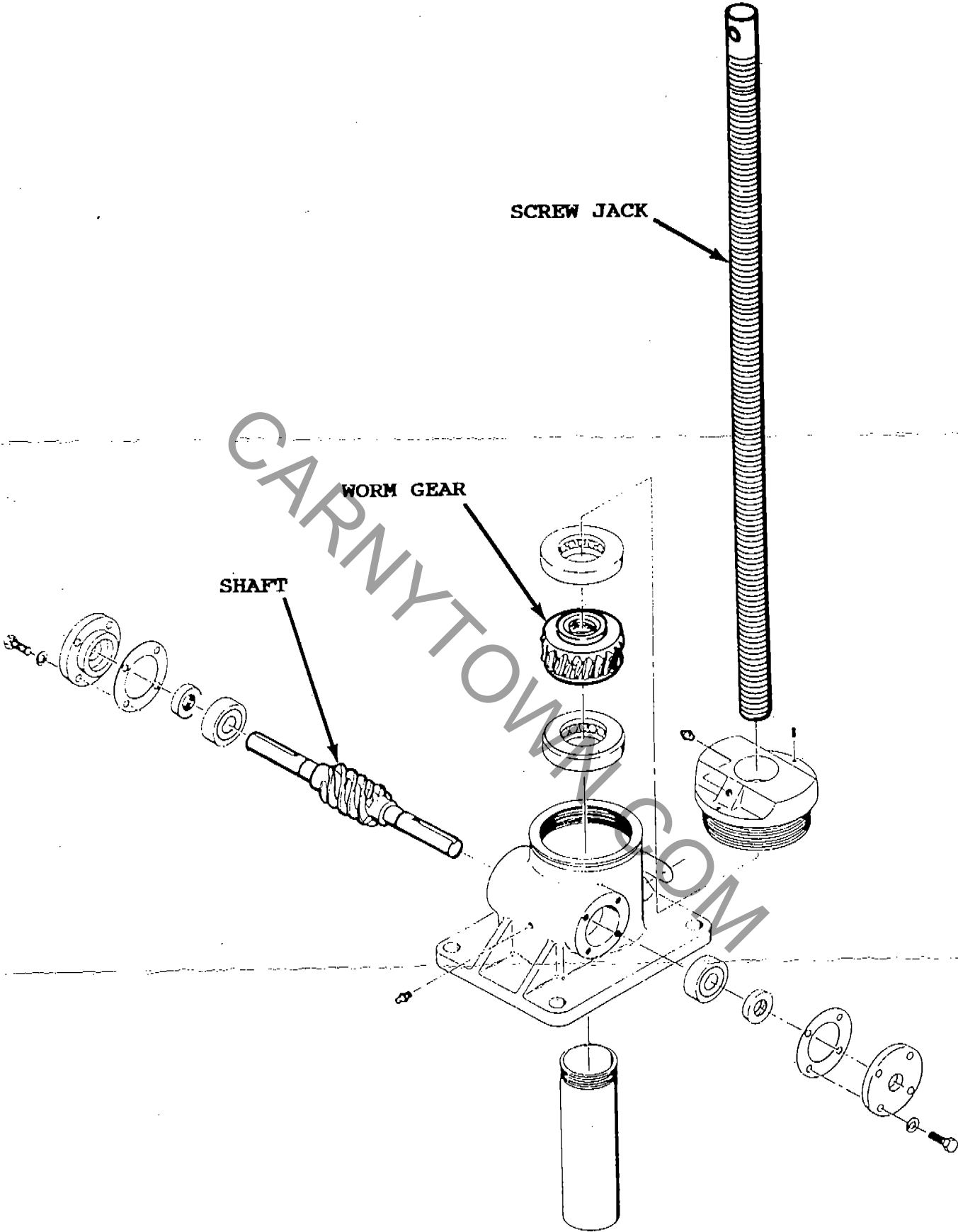



Florida Department of
Agriculture & Consumer Services

The Capitol
Tallahassee
32399-0810

BOB CRAWFORD
COMMISSIONER

PLEASE RESPOND TO:
Bureau of Fair Rides Inspection
3125 Conner Blvd., Bldg. 4
Tallahassee, FL 32399-9973
904/488-9790

December 09, 1993

MEMORANDUM

TO: All Inspection Specialist and Supervisors
FROM: Ron Safford, Chief, Bureau of Fair Rides Inspection
SUBJECT: Skywheel

A rim iron came off of the rim iron support assembly on a skywheel, at Pensacola. First the cap screw failed. The rim iron came off the rim iron support assembly and the safety cable failed. The light ballast then fell.

The purpose of the safety cable is to hold the rim iron on the rim iron support assembly in case of failure of the cap screw or retainer plate. It is not to support the rim irons when they come off the rim iron support assembly. Consequently, the length of the safety cable is crucial.

The length of the safety cable is 16 1/4 inches + or - 1/4 inch, measured from the outside edge of the inside of the snap to the same position on the other snap. Measurements longer than this may allow the rim iron to slip off and the cable to fail.

The Chance supplied safety cable is a plastic coated cable folded back on itself with a single barrel swage. The plastic extends through the swage. They do not have a two barreled swage. If you see a two barreled swage, it is not a Chance product. The show should be able to obtain and then provide engineering and quality control tests which demonstrates the pull strength to be the same or superior to that of the Chance product. Also, a snap with a flapper is not a Chance product and should meet the same pull strength. Again engineering and quality control data should be obtainable for the non-Chance product.

CARNYTOWN.COM

December 09, 1993
All Inspection Specialist
and Supervisors
RE: Skywheel
Page Two

In pull tests the Chance supplied safety cable did not fail until 595 pounds.

By the way, the failed safety cable apparently pulled through the non-Chance two barreled swage.

Review your Skywheel manual and bulletins. Enclosed is Service Bulletin 847-0357-00 which contains a good illustration of the safety cable.

RS/lp/rr

Enclosure

CARNYTOWN.COM

CARNYTOWN.COM