

# SPECIFICATION

MFG: CHANCE RIDES, INC.  
NAME: ROTOR

This ride conforms with all applicable ASTM amusement ride standards in effect on the date of

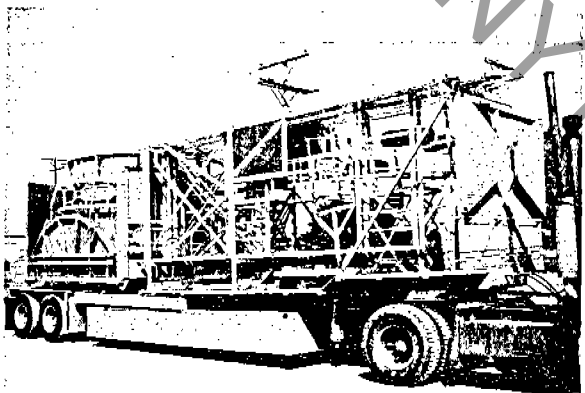
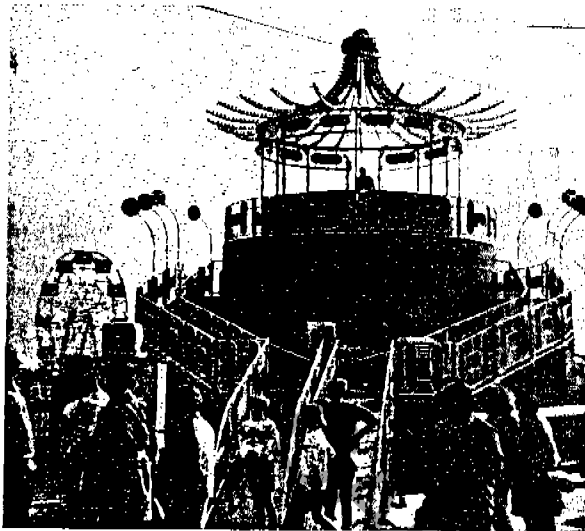

## SEATING

Maximum number  
of passengers ..... 20 adults or 30 children  
Maximum total passenger weight ..... 3,400 lbs.  
Minimum passenger height ..... 42 inches  
(unaccompanied by adult)  
Loading ..... All cars simultaneously  
Maximum unbalance ..... 4 adults (680 lbs.)

## PERFORMANCE

Direction of travel ..... Counter-clockwise  
Ride speed (maximum) ..... 32 rpm  
Ride duration (maximum) ..... 2½ min.  
Ride duration (recommended) ..... 2 min.  
Maximum wind speed (operating) ..... 35 mph  
Maximum wind speed (static) ..... 80 mph

## MAXIMUM RIDE WEIGHT (empty)

Portable model ..... 36,200 lbs.

DRIVE ..... Electro-Hydraulic

## POWER REQUIREMENTS

Total ..... 50 kW  
Motor ..... 15 kW  
Lights ..... 35 kW  
Minimum/Maximum line voltage ..... 208/230

## MOTOR

Type ..... 208 Y/460 volt, 3 phase, 60 Hz  
Horsepower rating ..... 15

LIGHTING ..... 110 volt incandescent

## STANDARD LEAD-IN CABLE (Portable Model)

Size ..... 2/4 type G  
Length ..... 50 ft.

## TRAILERING (Portable Model)

Height ..... 13 ft. 6 in.  
Width ..... 8 ft.  
Length ..... 40 ft.  
Total weight ..... 36,200 lbs.  
Rear axle weight ..... 24,500 lbs.  
Kingpin weight ..... 11,700 lbs.  
Tire size ..... 10:00 x 20 (12-Ply)

# ROTOR

Specifications are effective as of publication date. Because we try to improve every Chance Rides product, these specifications are subject to change without notice.

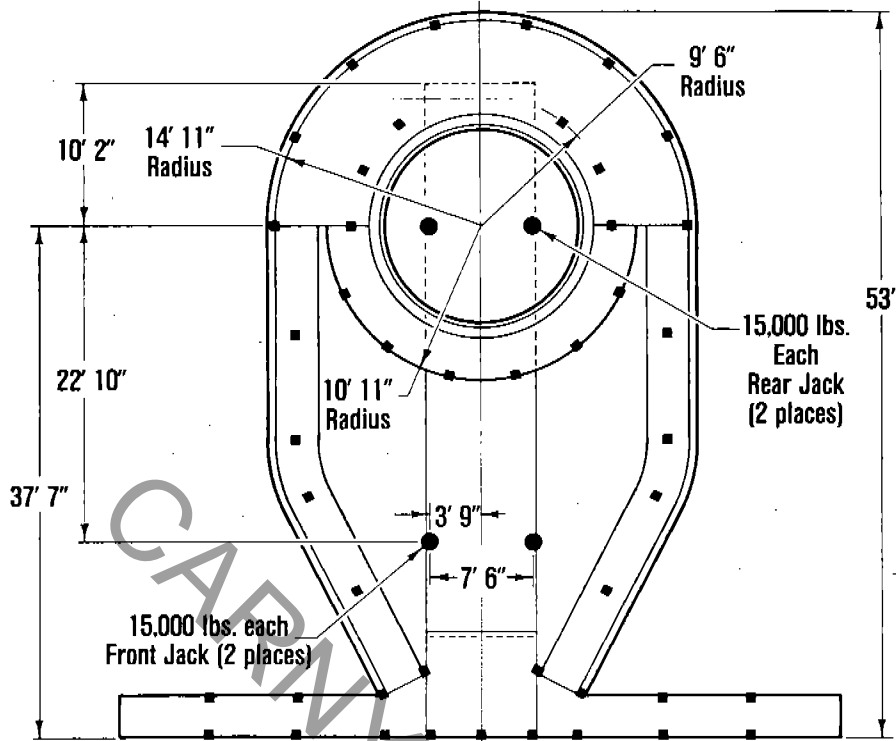

MIDWAY

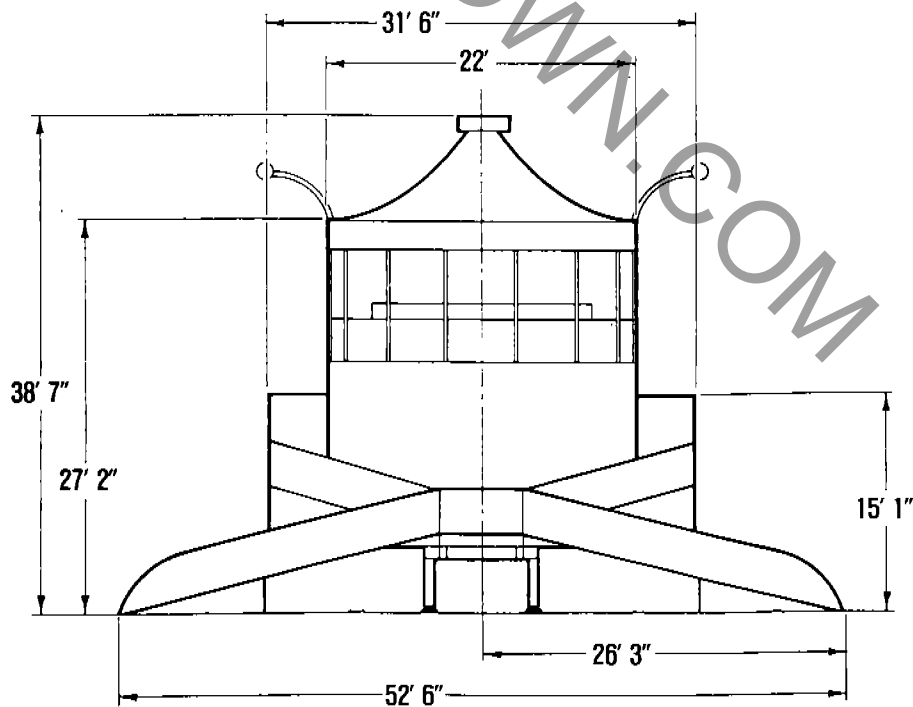

**RIDE CLEARANCE DIMENSIONS**

Ground Width .....	54 ft. frontage
Ground Depth .....	55 ft.
Maximum Height .....	40 ft.

CARNYTOWN.COM

ROTOR

Ride Serial Number \_\_\_\_\_ Owner \_\_\_\_\_ Date \_\_\_\_\_

FIELD INSPECTION POINTS

1. ( ) Inspect blocking and leveling.
2. ( ) Inspect lock nuts on leveling jacks.
3. ( ) Inspect hydraulic valves for leveling jacks.
4. ( ) Inspect cable leads, electrical connections and grounding per local code.
5. ( ) Inspect attach points of all ramps and platforms.
6. ( ) Inspect assembly of all fences.
7. ( ) Inspect barrel doors and locks.
8. ( ) Inspect barrel wall lining.
9. ( ) Inspect the assembly of the barrel, bolts and pins.
10. ( ) Inspect floor travel and stability of floor (Bulletin 100).
11. ( ) Inspect floor-to-barrel wall clearance (Bulletin B04-0219-00).
12. ( ) Inspect adjustment of floor guide rollers on track.
13. ( ) Inspect scissor rollers and pivot pins.
14. ( ) Check the speed of the ride - Maximum 33, minimum 28 (Bulletin B04-0219-00).
15. ( ) Inspect jack stands.
16. ( ) Inspect the ride for excessive vibration.
17. ( ) Inspect the structure for cracks, bad welds, etc.
18. ( ) Inspect electrical circuit for shorts, bad wires, etc.
19. ( ) Inspect for hydraulic leaks.
20. ( ) Inspect overall appearance of ride for cleanliness and general overall upkeep.

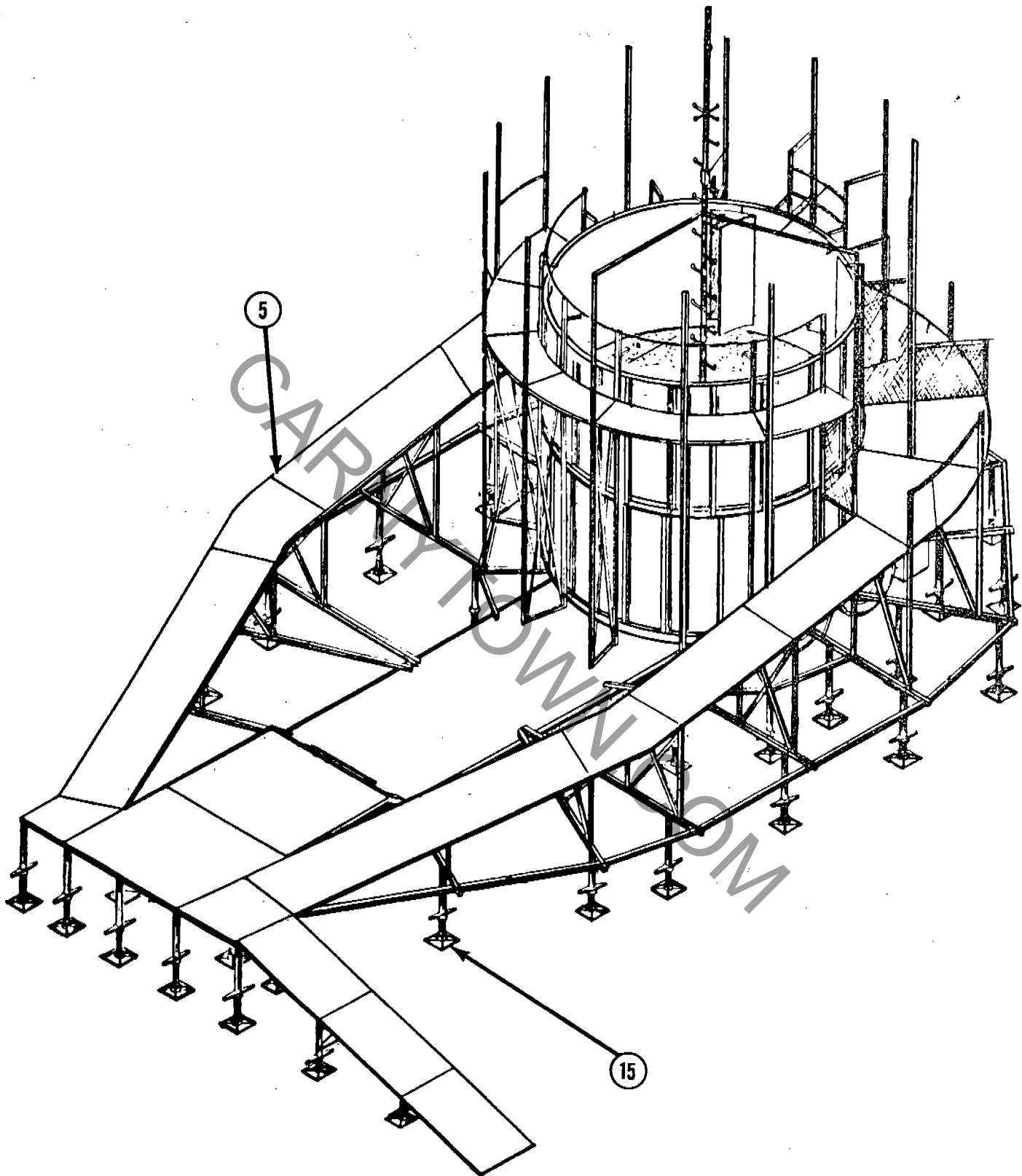

- 5. ( ) Inspect attach points of all ramps and platforms.
- 15. ( ) Inspect jack stands.

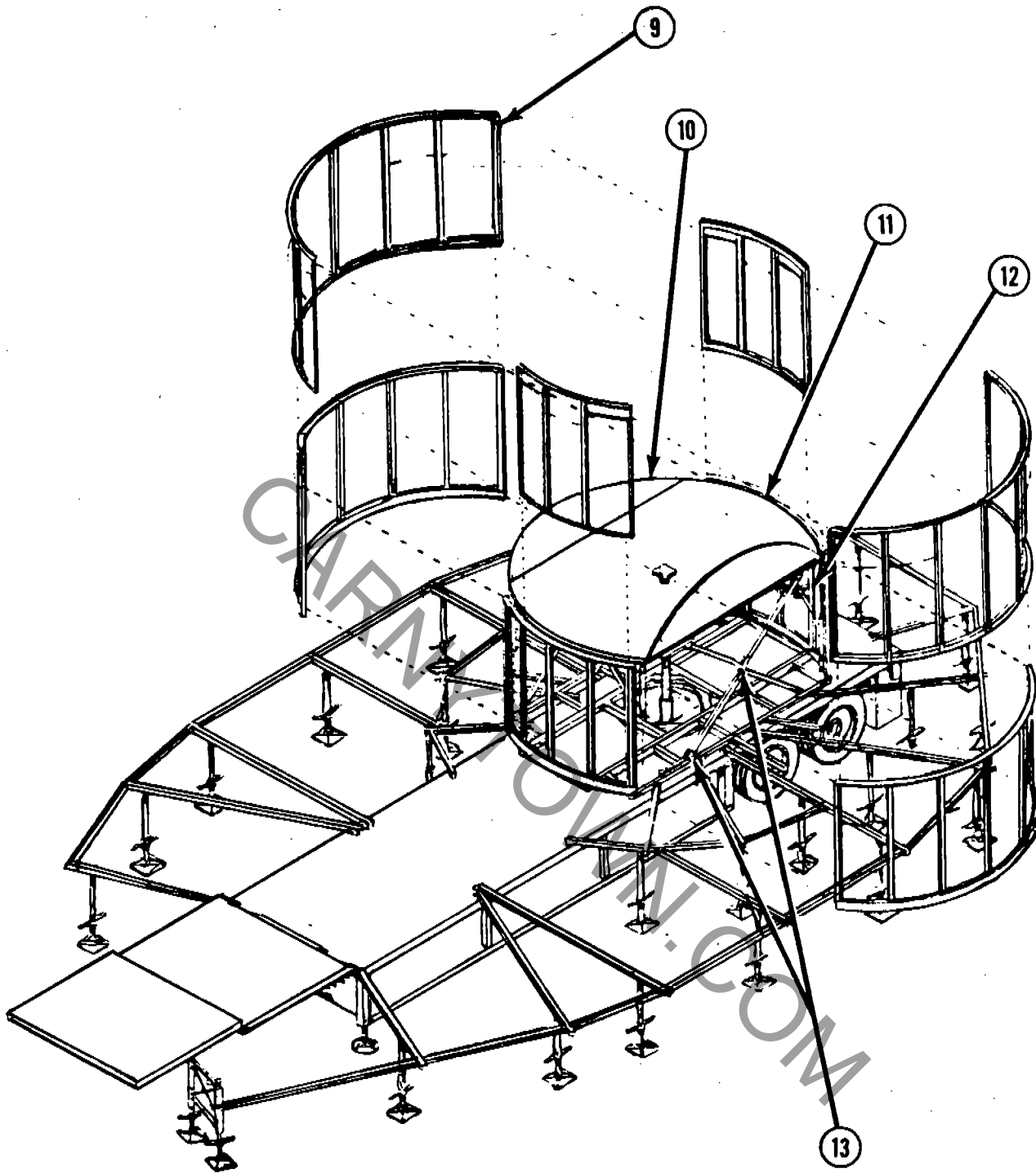

9. ( ) Inspect the assembly of the barrel, bolts and pins.
10. ( ) Inspect floor travel and stability of floor (Bulletin 100).
11. ( ) Inspect floor-to-barrel wall clearance (Bulletin B04-0219-00).
12. ( ) Inspect adjustment of floor guide rollers on track.
13. ( ) Inspect scissor rollers and pivot pins.

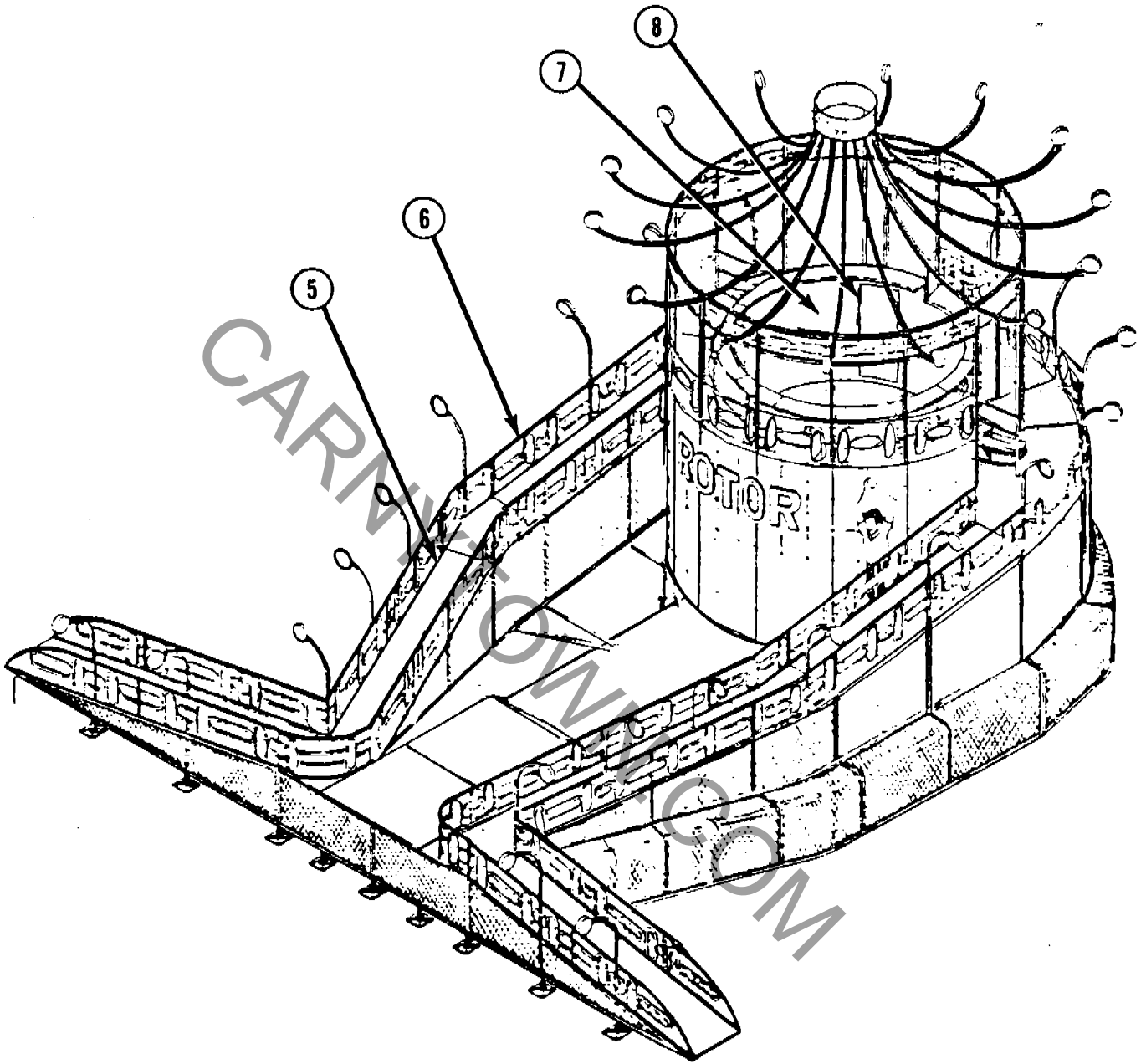

- 5. ( ) Inspect attach points of all ramps and platforms.
- 6. ( ) Inspect assembly of all fences.
- 7. ( ) Inspect barrel doors and locks.
- 8. ( ) Inspect barrel wall lining.
- 14. ( ) Check the speed of the ride - Maximum 33, minimum 28 (Bulletin B04-0219-00).

CARNYTOWN.COM



Number: B04-0219-00

Date: 4-22-81

Supersedes:

*America's Largest Manufacturer of Amusement Rides*

## SERVICE BULLETIN

Effective Serial Numbers: ALL UNITS

Ride: ROTOR

Subject: OPERATIONAL SEQUENCE AND  
GENERAL INSPECTION

This Bulletin is being issued to point out several operating and maintenance practices on the Rotor that are necessary to maintain the Safety of the ride and its passengers.

Inspection of the ride must be performed by competent, qualified mechanics capable of understanding the function of the parts and their proper installation.

### OPERATING PROCEDURE

NOTE: Chance Manufacturing Co., Inc. recommends that the following procedure be followed for the greatest possible safety of passengers.

1. Load passengers, making sure they are evenly distributed around barrel.
2. Start rotation of barrel and let it reach its full operating RPM (28-33 RPM)
3. LOWER FLOOR TO BOTTOM POSITION.
4. Raise floor slowly until it is just below the feet of the lowest person.
5. Slow down rotation of barrel gradually letting passengers slowly slide down to meet the floor until the ride has stopped.
6. When barrel has completely stopped, ask passengers to step to the center of the floor.
7. Slowly raise the floor to door level and exit passengers.

### FLOOR INSPECTION

Because of normal wear in rollers, and floor scissors, the floor of the Rotor may become tilted, leaving a larger space between the floor and the barrel on one side than the other. To prevent this from causing an accident (pinched feet) floor rollers and rollers on floor scissors must be inspected periodically.

Factory and Sales Office: 4219 Irving • P.O. Box 12328 • Wichita, Kansas 67277 • (316) 942-7411

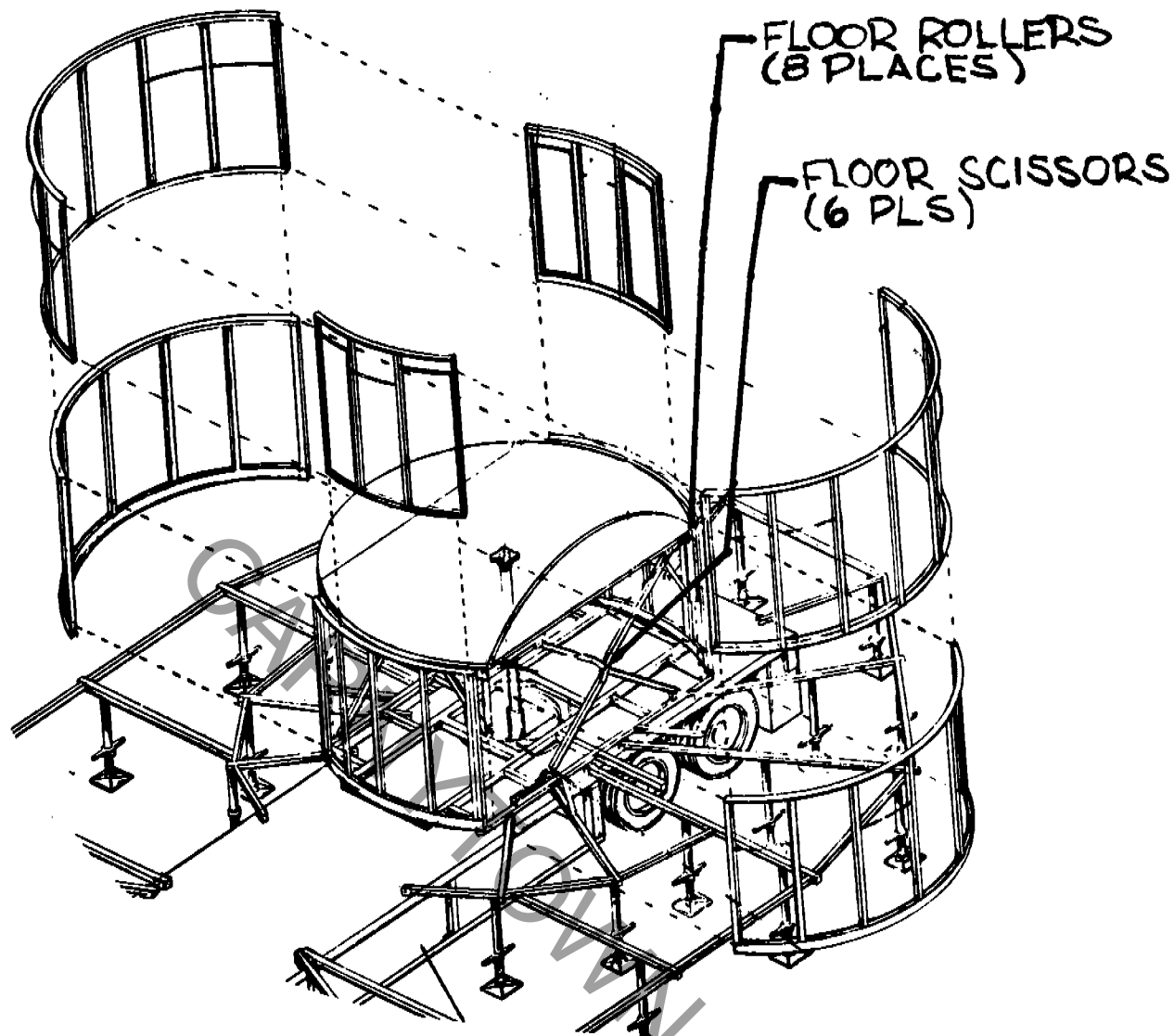

A maximum allowable opening between floor and barrel should be no more than 5/8" to 3/4" on all sides. If more than this amount is found on any side, please contact Chance Manufacturing Co., Inc. for proper replacement, repair or adjustment procedures.

#### BARREL RUBBER INSPECTION

Inspect condition of textured rubber on barrel periodically. Make sure that a sufficient amount of texture is left on rubber (not smooth). Check to see that there are no loose edges and that all attaching hardware (rivets, etc.) are intact and in good repair.



Number: 100

Date: 4-9-75

Supersedes:

America's Largest Manufacturer of Amusement Rides

## SERVICE BULLETIN

Effective Serial Numbers: 67-1607, 69-1612, 72-1619 & ON

Ride: ROTOR

Subject: PLUMBING CORRECTION AND  
BARREL CREEPING

A problem area has recently shown up in the Hydraulic Circuit on the ROTOR.

The problem is in the method of plumbing the Floor Directional Control Valve and is causing the oil to heat up.

An explanation of what is happening, along with corrective action instructions, follows.

The corrective action should be carried out immediately, even if no problems have been experienced with hot oil.

Reducing the temperature of the oil will prolong the life of components in the system.

### EXPLANATION

The existing method of plumbing is not allowing the Directional Control Valves to drain adequately. Thus, when the floor is being lowered, the Floor Control Valve does not shift all the way because of back pressure on it. The valve shifts just enough to allow some flow to pass from port A to T, allowing the floor to lower.

However, since the valve has not shifted fully, the connection between port P & B is incomplete. The Hydraulic Pump is, therefore, forced to pump oil over the Relief Valve which is set at 1000 PSI.

The Hydraulic Oil being forced over relief is causing the oil to get hot.

### PARTS REQUIRED

#### Quantity

1	1/4 NPT Plug
1	290-01383 Adapter
1	1/2-1/4 NPT Bushing
1	372-605-8 Hose Assy.

Factory and Sales Office: 4219 Irving • P.O. Box 12328 • Wichita, Kansas 67277 • (316) 942-7411

## CORRECTIVE ACTION

Looking at the Control Valves from the rear of the trailer, the one on the Left controls the Floor Cylinder, the Right one the Hydraulic Motor.

The ports are identified by Letter Codes, A, B, P, T, X and Y. Coming out of Port B on the Floor Cylinder Valve is a "Tee" with an extra port in the side of it, see Photo 1.

Disconnect the 1/4" hose coming from the "Tee, Port B" and going to the "Tee, Port ".

Install the pipe plug in the "Tee, Port B".

Connect the new hose to the extra tank port as shown in Photo 2.

### NOTE

When installing new hose, have the hose end close to the port so it can be started quickly to avoid losing much oil.

Connect other end of hose to " " Port where the original hose was removed.

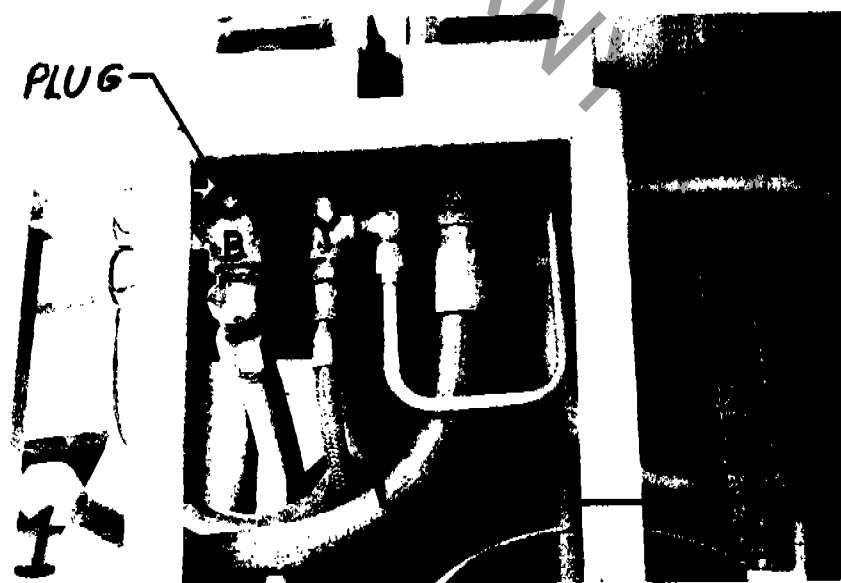

HOSE CAN BE CONNECTED TO THE  
"TEE Y PORT" EITHER POSITION

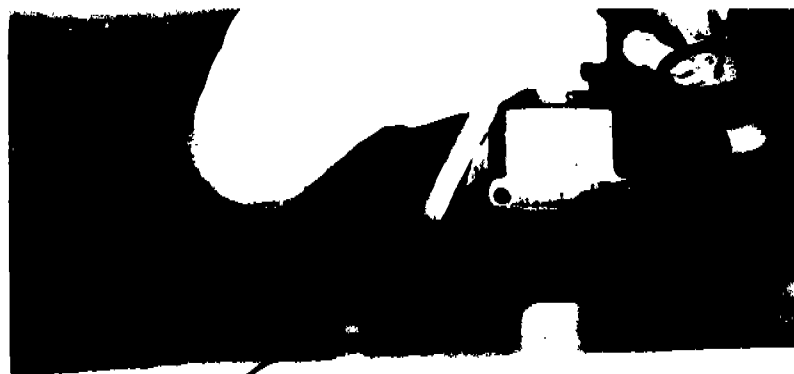

90 DEG PIPE SWIVEL SHOWN BUT  
NOT NECESSARY, SCREW HOSE END  
INTO BUSHING

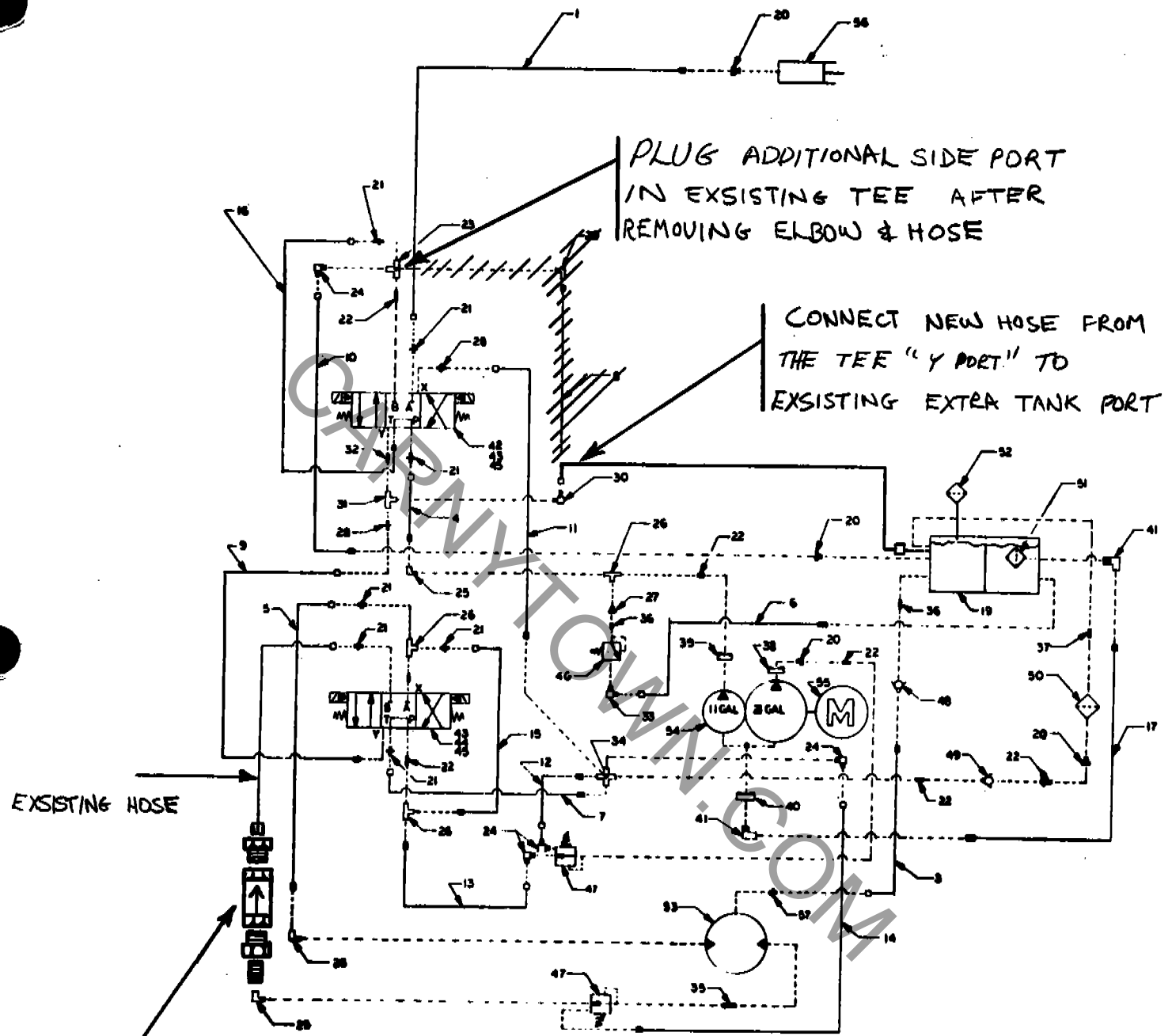

PLUG ADDITIONAL SIDE PORT  
IN EXISTING TEE AFTER  
REMOVING ELBOW & HOSE

CONNECT NEW HOSE FROM  
THE TEE "Y PORT" TO  
EXISTING EXTRA TANK PORT

EXISTING HOSE

ADD NEW CHECK  
VALVE, BUSHINGS &  
CLOSE NIPPLE BETWEEN  
HOSE & ST. ELBOW :

## BARREL CREEPING

With some rides the barrel section tends to creep slightly during the loading sequences. The corrective action taken by this kit may eliminate the problem for some operators, since it will reduce the operating temperature of the Hydraulic Oil.

However, it may not be adequate for rides hauling a large number of passengers or if the Directional Control Valve happens to have a loose fitting spool.

To stop Barrel Creeping, a Check Valve can be added in the return line from the motor. This will equalize pressure on both sides of the motor.

### OPTIONAL PARTS REQUIRED

#### Quantity

2	1 1/4-3/4 NPT Bushing
1	3/4 NPT Close Nipple
1	290-84405 Check Valve

#### Addition of Check Valve

Remove the Drive Tire to facilitate access to bottom side of Hydraulic Motor and Relief Valve.

Remove Hose going from the Relief Valve to B Port of the Directional Valve.

Screw the Check Valve with nipple and bushings into the St. Elbow on the bottom side of the Relief Valve.

#### CAUTION

Be sure Check is installed with Arrow pointing away from Relief Valve.

Re-connect Hose from Check Valve to B Port of the Directional Control Valve.

Test run ride and observe for leaks.

