

SPECIFICATIO

MFG: CHANCE RIDES, INC.
 NAME: MUSIC FEST
 TYPE: NON-KIDDIE

All specifications in accordance with ASTM standards where

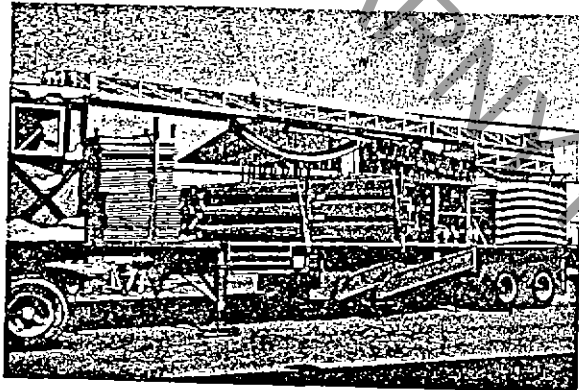
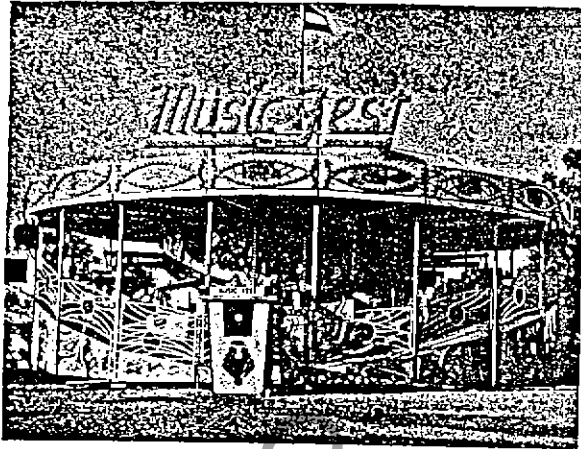

SEATING

Number of cars 18
 Maximum number of passengers
 per car 2 adults or 3 children
 Maximum passenger weight
 per car 340 lb.
 Maximum total number of
 passengers 36 adults or 54 children
 Maximum total passenger weight 6,120 lb.
 Loading All cars simultaneously

PERFORMANCE

Direction of travel .. Clockwise and counter-clockwise
 Ride Speed (maximum) 13 rpm
 Ride duration (maximum) 2½ min.
 Ride duration (recommended) 2 min.

DRIVE Electro-Hydraulic

POWER REQUIREMENTS

Total 50 kW
 Motor 15 kW
 Lights 35 kW
 Minimum/Maximum line voltage 208/230

MOTOR

Type 208 Y/460 volt, 3 phase, 60 Hz
 Horsepower rating 20

LIGHTING 110 volt incandescent

STANDARD LEAD-IN CABLE

Size 2/4 type G
 Length 50 ft.

MUSIC Baptist Model No. BRD 617 TP

TRAILERING

	Main Traller	Auxillary Trailer
Height	13 ft. 6 in.	13 ft. 6 in.
Width	8 ft.	8 ft.
Length	40 ft.	40 ft.
Total weight	49,780 lb.	30,750 lb.
Rear axle weight	31,600 lb.	17,650 lb.
Kingpin weight	18,180 lb.	13,100 lb.
Tire size	9:00 x 20	9:00 x 20

Because we try to improve every Chance product, these specifications are subject to change without notice.

The most complete line of amusement rides for all ages.



4219 Irving
 P.O. Box 12328
 Wichita, KS 67277-2328

Telephone (316) 942-7411

MUSIC FEST

OPERATING DIMENSIONS

(Includes Clearance)

Ground Width.....57 ft. frontage
 Ground Depth.....54 ft.
 Maximum Height.....28 ft.

GROUND AREA REQUIRED FOR MUSIC FEST

(No Clearance Allowances)

GROUND TO HIGH POINT OF RIDE - 28 ft. AT TOP OF TENT POLE

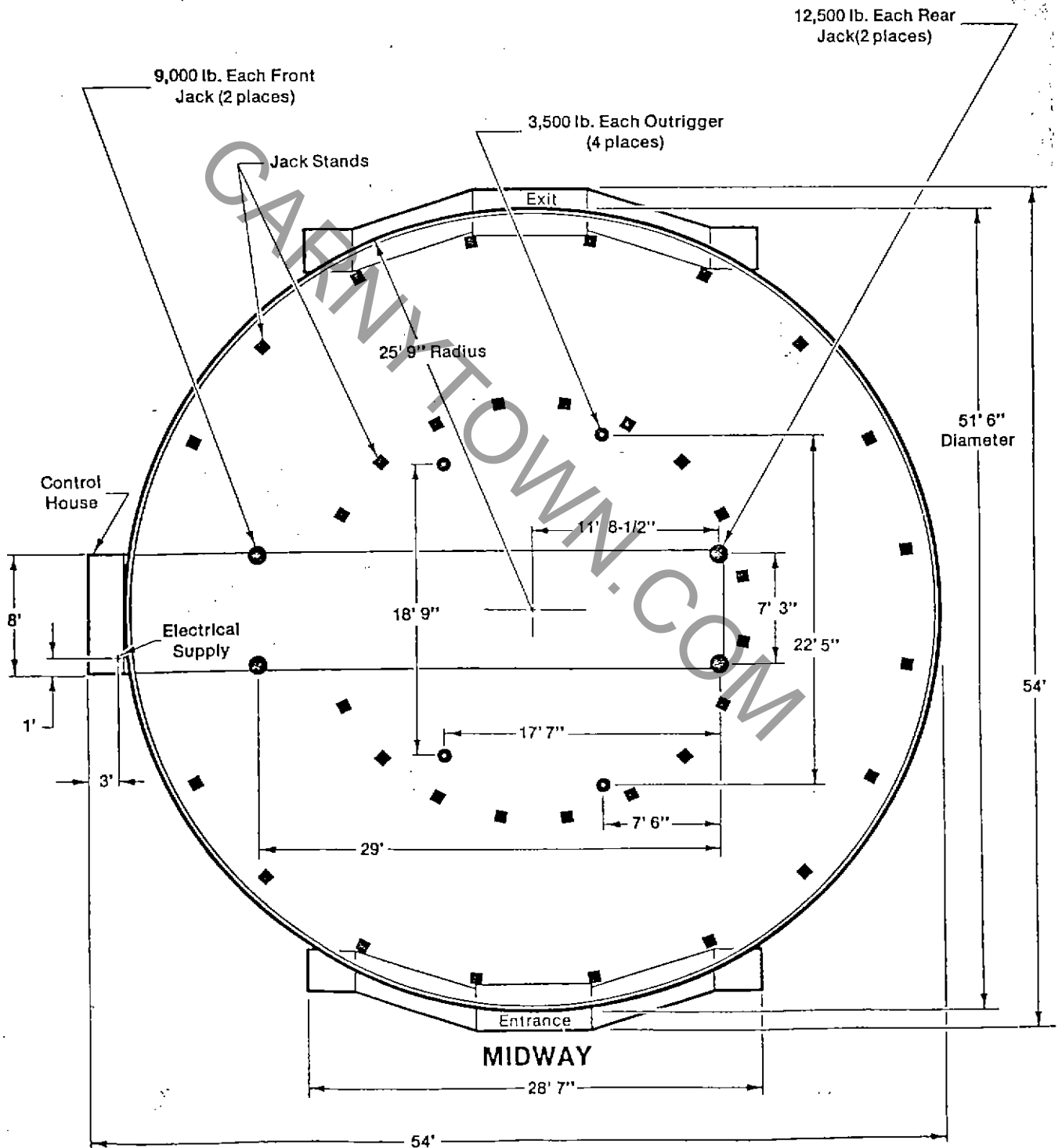

SPECIFICATIONS

All specifications in accordance with ASTM standards where applicable.

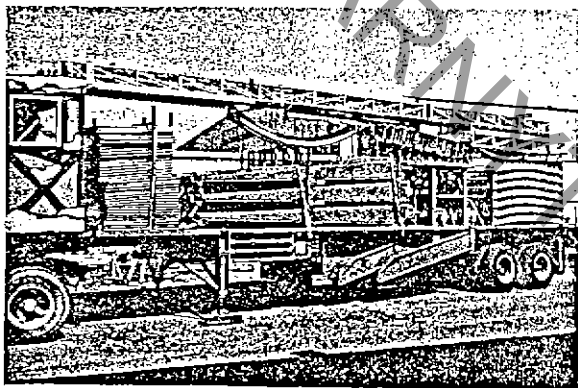
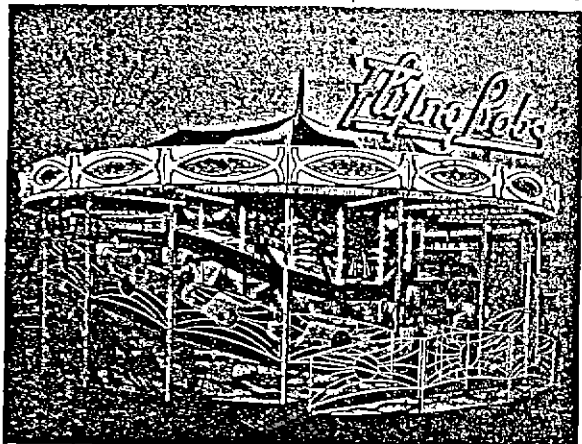

SEATING

Number of cars 18
 Maximum number of passengers
 per car 2 adults or 3 children
 Maximum passenger weight
 per car 340 lb.
 Maximum total number of
 passengers 36 adults or 54 children
 Maximum total passenger weight 6,120 lb.
 Loading All cars simultaneously

PERFORMANCE

Direction of travel .. Clockwise and counter-clockwise
 Ride Speed (maximum) 13 rpm
 Ride duration (maximum) 2½ min.
 Ride duration (recommended) 2 min.

DRIVE Electro-Hydraulic

POWER REQUIREMENTS

Total 50 kW
 Motor 15 kW
 Lights 35 kW
 Minimum/Maximum line voltage 208/230

MOTOR

Type 208 Y/460 volt, 3 phase, 60 Hz
 Horsepower rating 20

LIGHTING 110 volt incandescent

STANDARD LEAD-IN CABLE

Size 2/4 type G
 Length 50 ft.

MUSIC Baptist Model No. BRD 617 TP

Trailering	Main Trailer	Auxiliary Trailer
Height	13 ft. 6 in.	13 ft. 6 in.
Width	8 ft.	8 ft.
Length	40 ft.	40 ft.
Total weight	49,780 lb.	30,750 lb.
Rear axle weight	31,600 lb.	17,650 lb.
Kingpin weight	18,180 lb.	13,100 lb.
Tire size	9:00 x 20	9:00 x 20

Because we try to improve every Chance product, these specifications are subject to change without notice.



The most complete line of amusement rides for all ages.

4219 Irving
 P.O. Box 12328
 Wichita, KS 67277-2328

Telephone (316) 942-7411

FLYING BOOBS

OPERATING DIMENSIONS

(Includes Clearance)

Ground Width.....57 ft. frontage
 Ground Depth.....54 ft.
 Maximum Height.....28 ft.

GROUND AREA REQUIRED FOR FLYING BOB'S

(No Clearance Allowances)

GROUND TO HIGH POINT OF RIDE - 28 ft. AT TOP OF TENT POLE

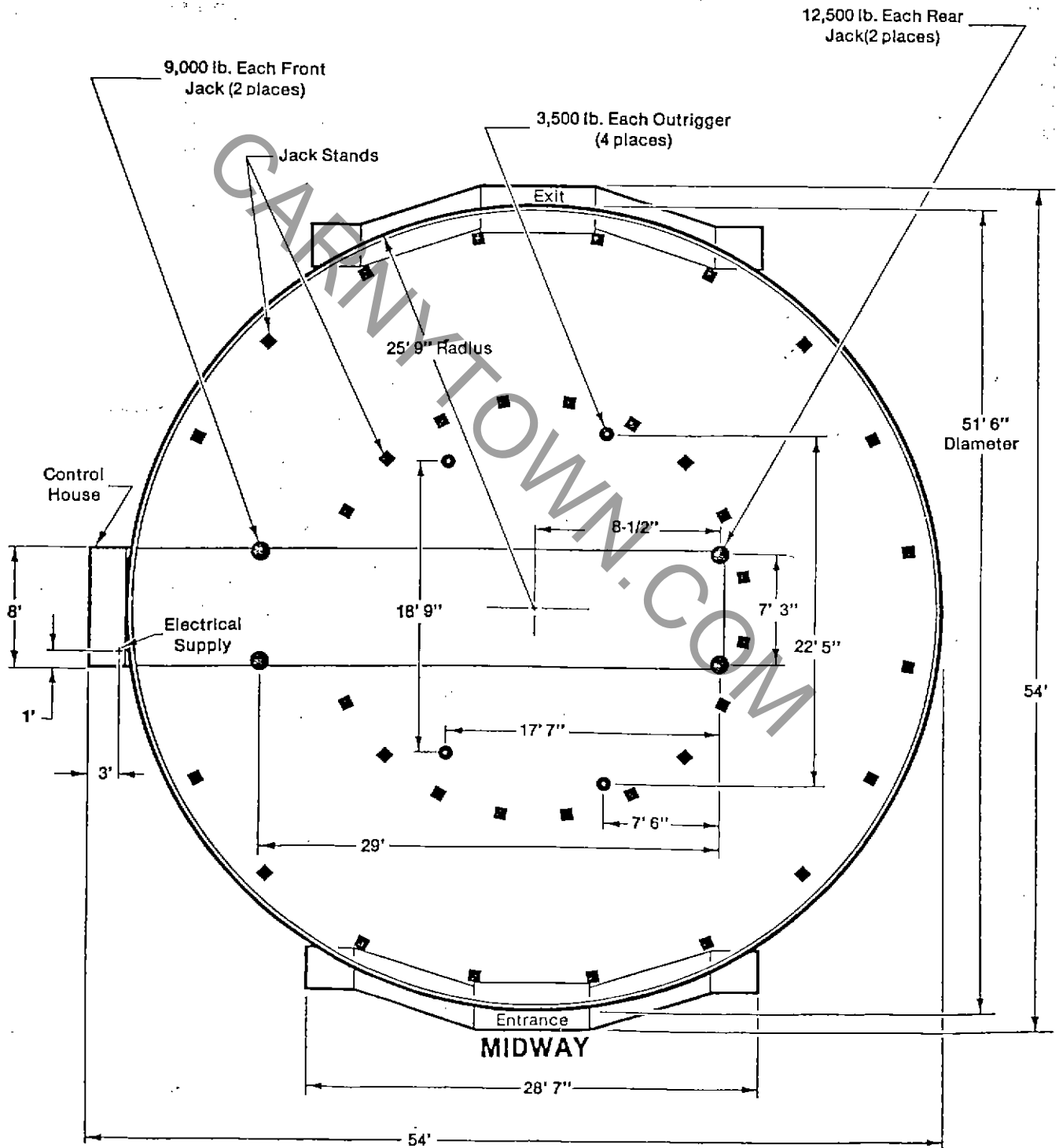

**MUSIC FEST
FLYING BOBS**

CARNYTOWN.COM

FLYING BOBS / MUSIC FEST

Ride Serial Number _____ Owner _____ Date _____

FIELD INSPECTION POINTS

1. () Inspect blocking and leveling.
2. () Inspect lock nuts on leveling jacks.
3. () Inspect hydraulic valves for leveling jacks.
4. () Inspect cable leads, electrical connections and grounding per local code.
5. () Inspect fences and platforms for proper installation and leveling. Check all jack stands.
6. () Inspect center hub bearing capscrews for proper torque and Grade 8 (Bulletins B37-0139-0B and B37-0143-0B).
7. () Inspect all track capscrews for torque and Grade 5.
8. () Check the capscrews in the master sweep bearing caps for size and torque. These capscrews are 7/8-9 Grade 8 (Bulletin B37-0318-00).
9. () Inspect safety wires in the sweep spindle shafts.
10. () Inspect safety wires in the roller shaft capscrews.
11. () Inspect the bearings and capscrews in the roller cradle assemblies.
12. () Inspect the sweep attach points, attaching pins and lynch pins (Bulletin B37-0234-0A).
13. () Inspect the sweep rollers for lubrication and track contact (contact is controlled by spreader bar adjustment).
14. () Inspect the vehicle hanger assemblies (Bulletin 140).
15. () Inspect the complete vehicle assembly, including the seat belt, seat belt sign, and lap bar and lock.
16. () Inspect the seat arm bumpers on the sweeps.
17. () Inspect the shock band assemblies between seats - 5 bands minimum.
18. () Inspect the vehicle frame safety cables.
19. () Inspect the vehicle frames and frame pivots (Bulletins 140 and B37-0337-00).
- 19A. () Inspect the upper inner scenery panels for retainers (Bulletin B37-0294-00).
20. () Inspect spreader bars, attach points, and cross rods (Bulletins B37-0330-00).
21. () Inspect operating controls, including the remote stop/bell switch and foot switch, if equipped. THE RIDE MUST HAVE TWO OPERATORS, one in the control house and one opposite (180°) on the platform.
22. () Inspect jack stands.
23. () Inspect performance of track rollers at low speed.
24. () Check low speed of ride - 6X rpm maximum both directions.
25. () Check high speed of ride - 13 rpm maximum both directions.
26. () Check oscillation of vehicles.
27. () Check ride for excessive vibration.
28. () Inspect the structure for cracks, bad welds, etc.
29. () Inspect electrical wiring for short circuits, bad wires, etc.
30. () Inspect for hydraulic leaks.
31. () Inspect overall appearance of ride for cleanliness and general overall upkeep.
32. () Inspect center hub and spindles (Bulletin A37-0250-00).
33. () Inspect spreader bar adjustment (Bulletin B37-0251-0B).

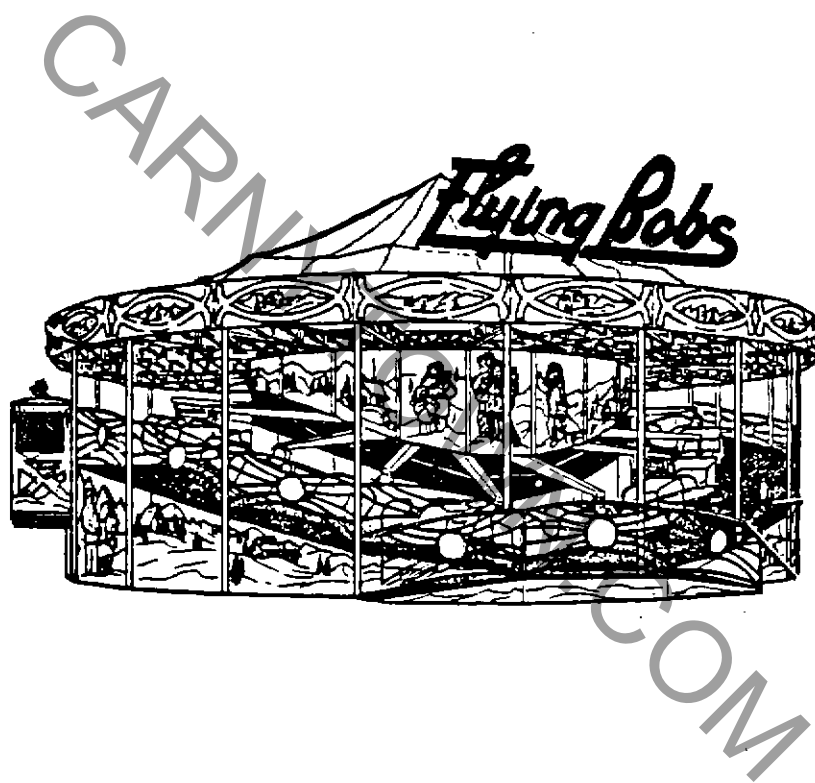

- 24. () Check low speed of ride - 6% rpm maximum both directions.
- 25. () Check high speed of ride - 13 rpm maximum both directions.
- 26. () Check oscillation of vehicles.

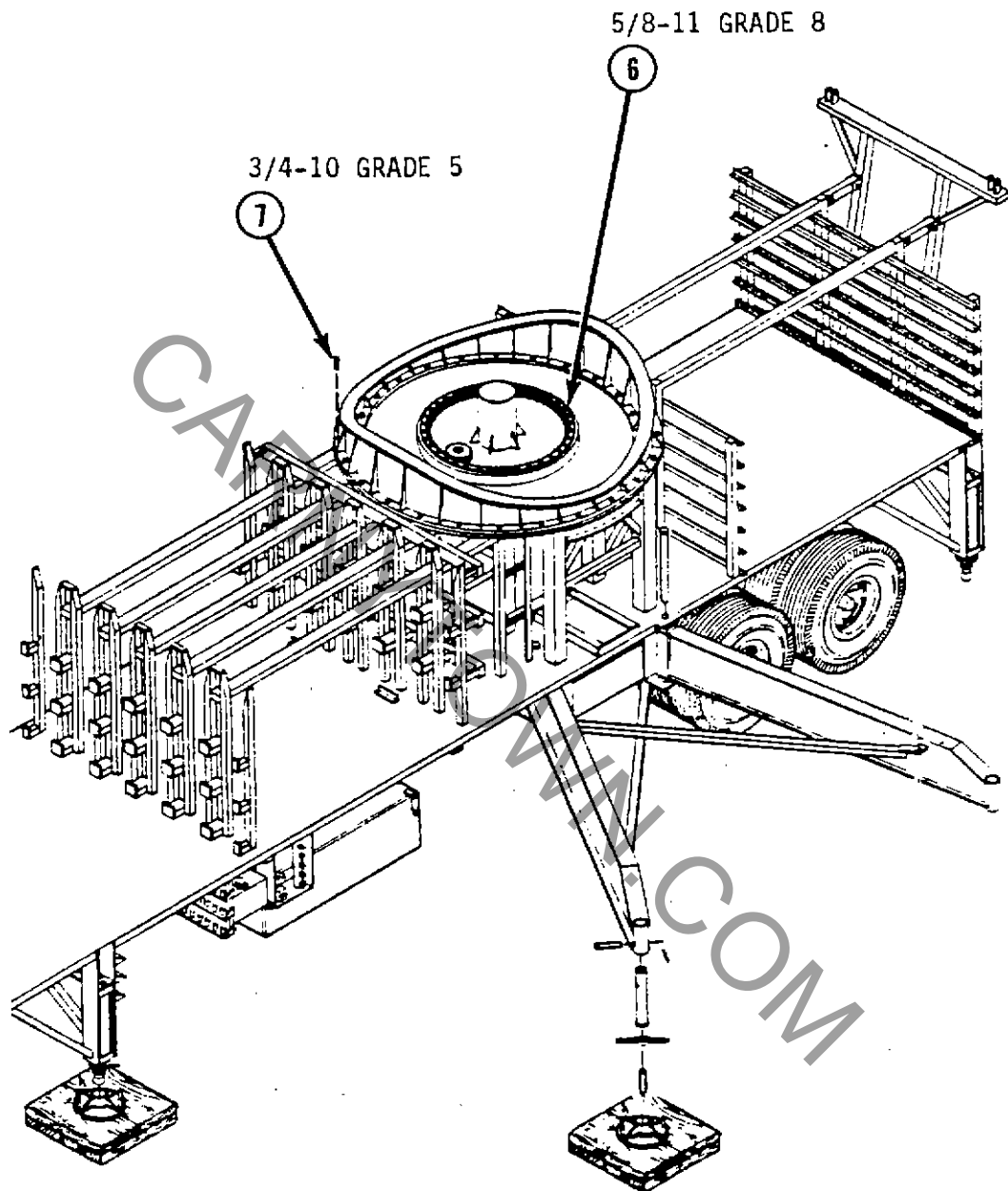

6. () Inspect center hub bearing cap screws for proper torque and Grade 8 (Bulletins B37-0139-08 and B37-0143-08).
7. () Inspect all track cap screws for torque and Grade 5.

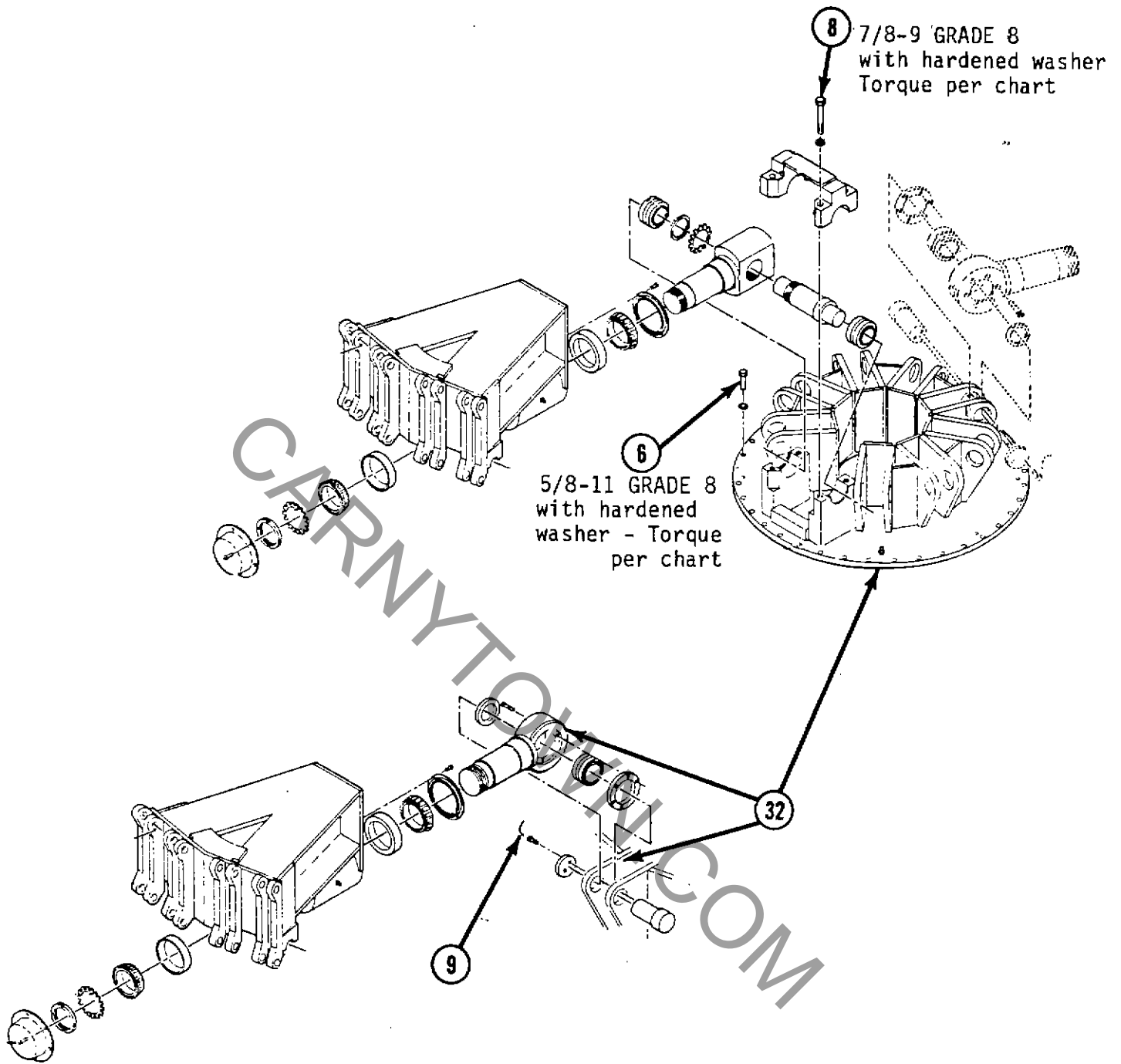

- 6. () Inspect center hub bearing capscrews for proper torque and Grade 8 (Bulletins B37-0139-0B and B37-0143-0B).
- 8. () Check the capscrews in the master sweep bearing caps for size and torque. These capscrews are 7/8-9 Grade 8 (Bulletin B37-0318-00).
- 9. () Inspect safety wires in the sweep spindle shafts.
- 32. () Inspect center hub and spindles (Bulletin A37-0250-00).

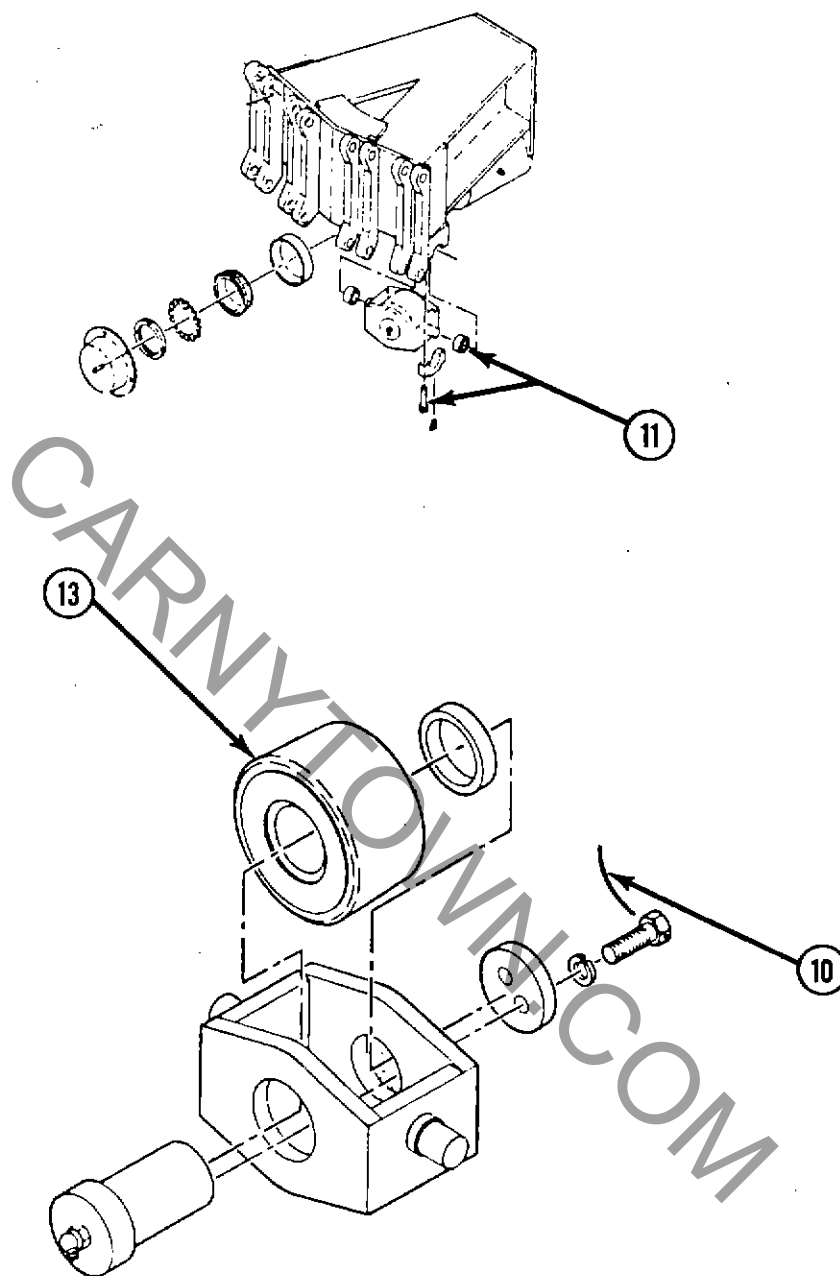

- 10. () Inspect safety wires in the roller shaft capscrews.
- 11. () Inspect the bearings and capscrews in the roller cradle assemblies.
- 13. () Inspect the sweep rollers for lubrication and track contact (contact is controlled by spreader bar adjustment).

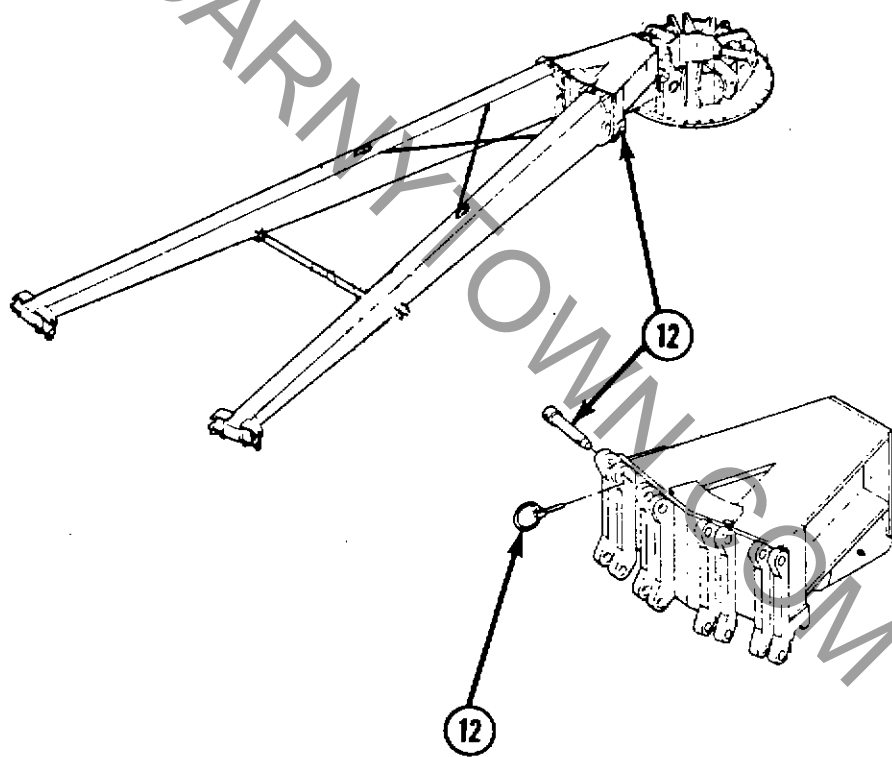

12. () Inspect the sweep attach points, attaching pins and lynch pins (Bulletin 837-0234-00).

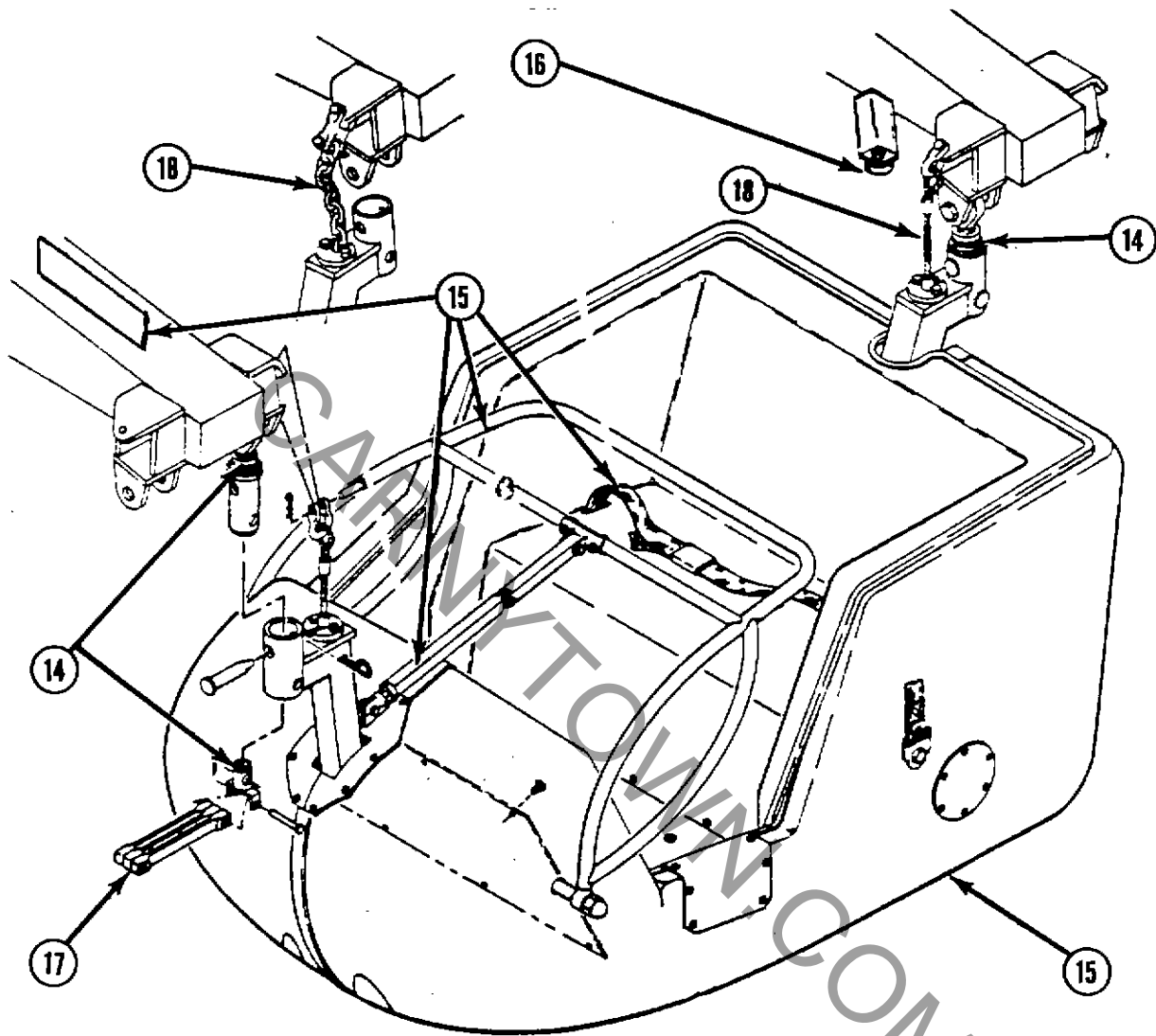

- 14. () Inspect the vehicle hanger assemblies Bulletin 140).
- 15. () Inspect the complete vehicle assembly, including the seat belt, seat belt sign, and lap bar and lock.
- 16. () Inspect the seat arm bumpers on the sweeps.
- 17. () Inspect the shock band assemblies between seats - 5 bands minimum.
- 18. () Inspect the vehicle frame safety cables.

SPECIAL CHANCE BOLT

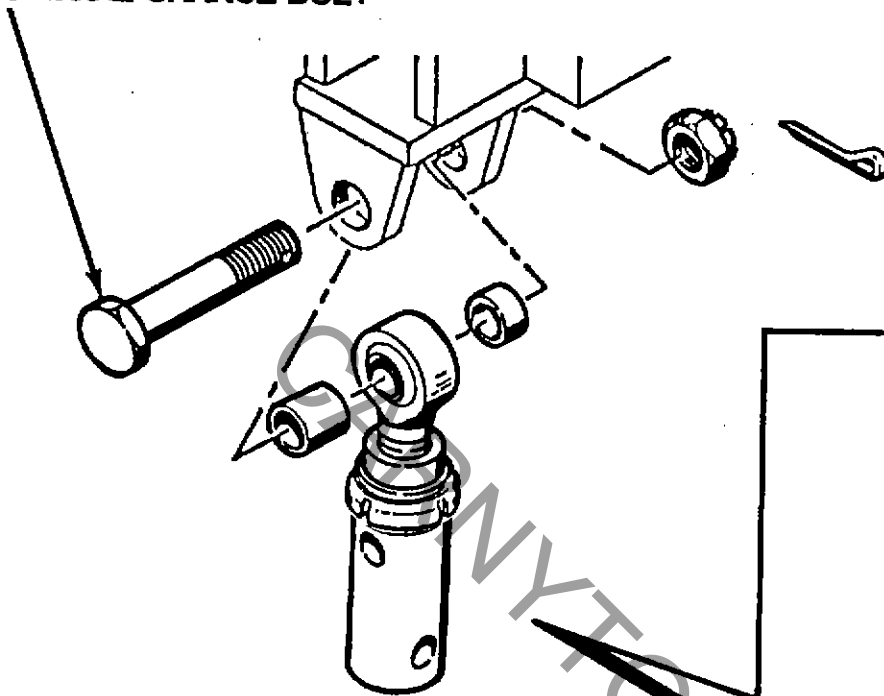

**NEW STYLE
NON-REPAIRABLE
(ONE-PIECE)**

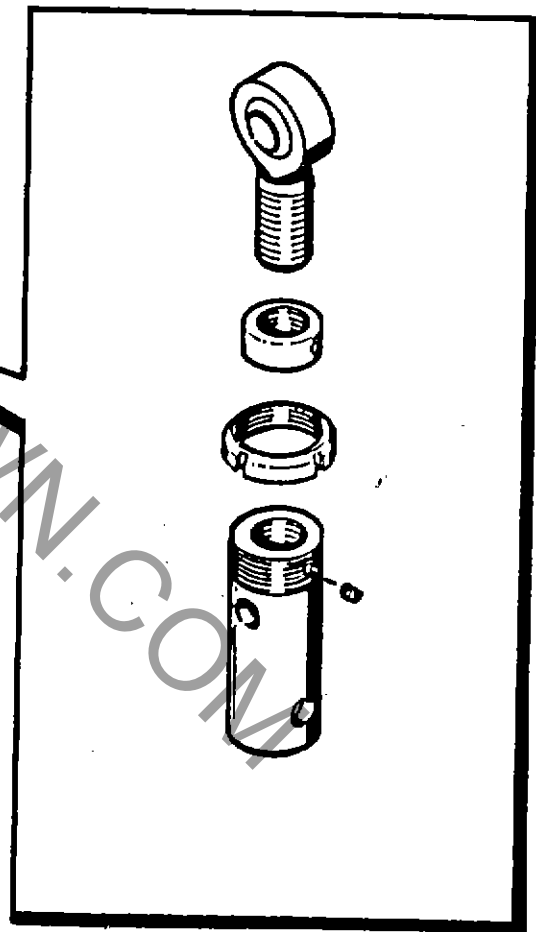

**OLD STYLE
REPLACEABLE ROD ENDS**

14. () Inspect the vehicle hanger assemblies (Bulletin 140).

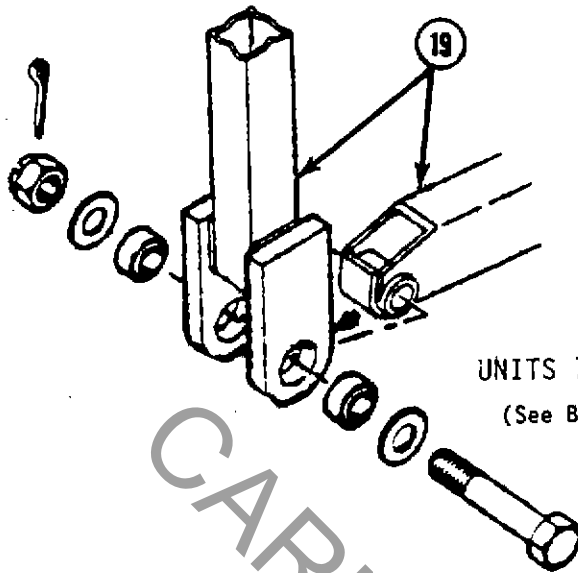

UNITS 71-2701 through 76-2732
 (See Bulletin B37-0337-00)

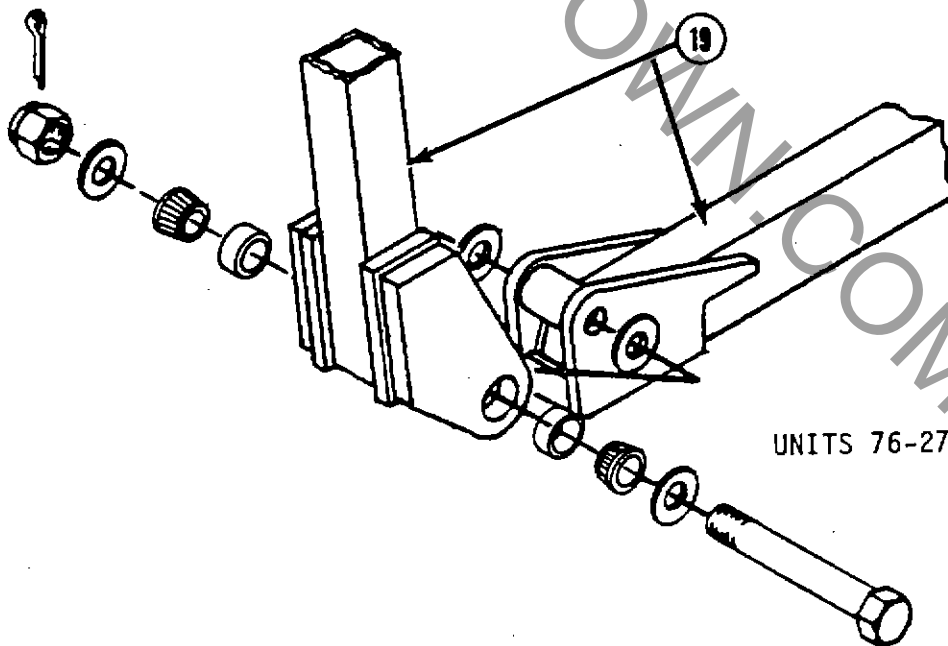

UNITS 76-2733 and on

19. () Inspect the vehicle frames and frame pivots
 (Bulletins 140 and B37-0337-00).

NOTE: Remove vehicle floor to inspect frame
 pivot.

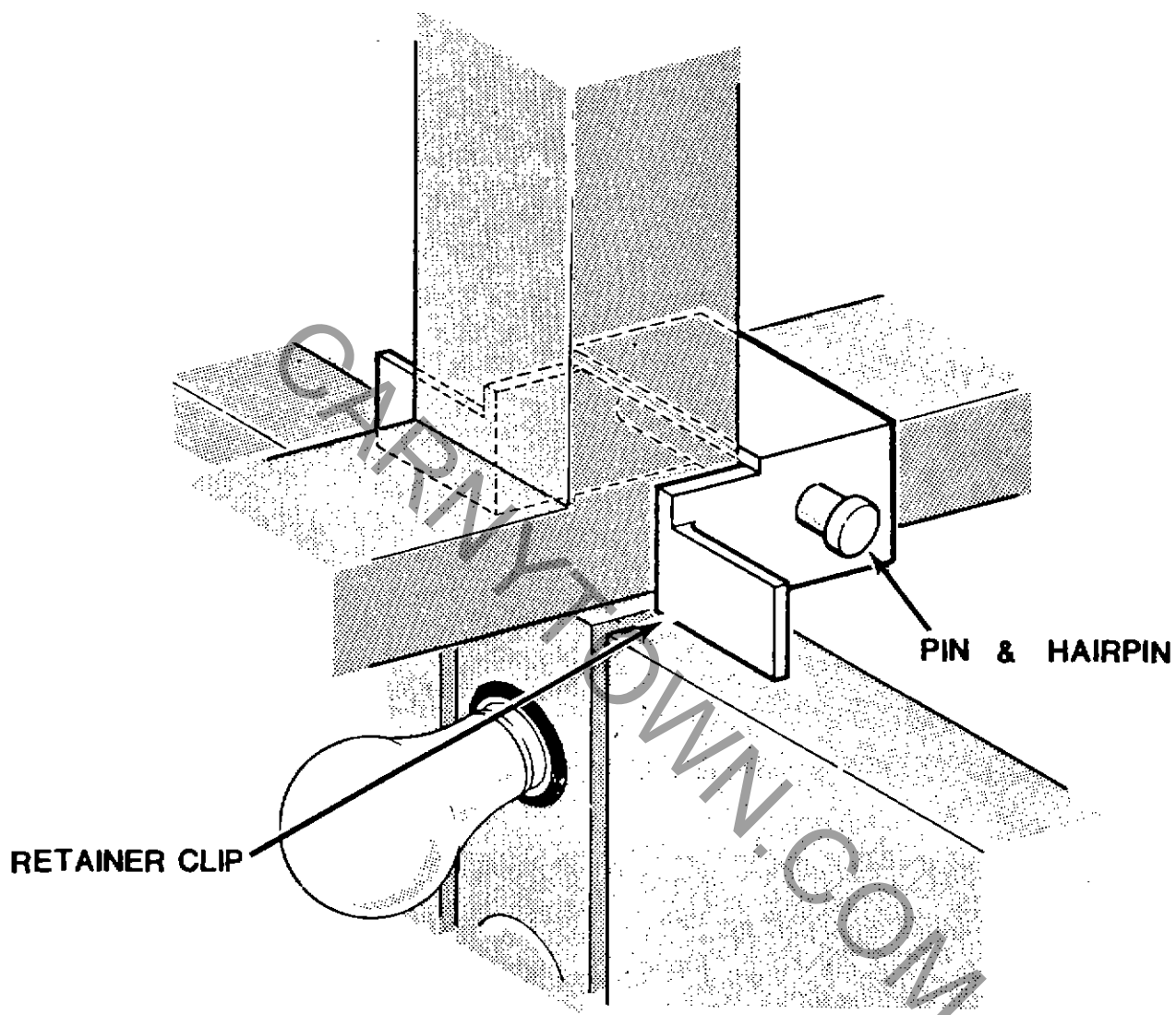

19A.() Inspect the upper inner scenery panels for retainers (Bulletin B37-0294-00).

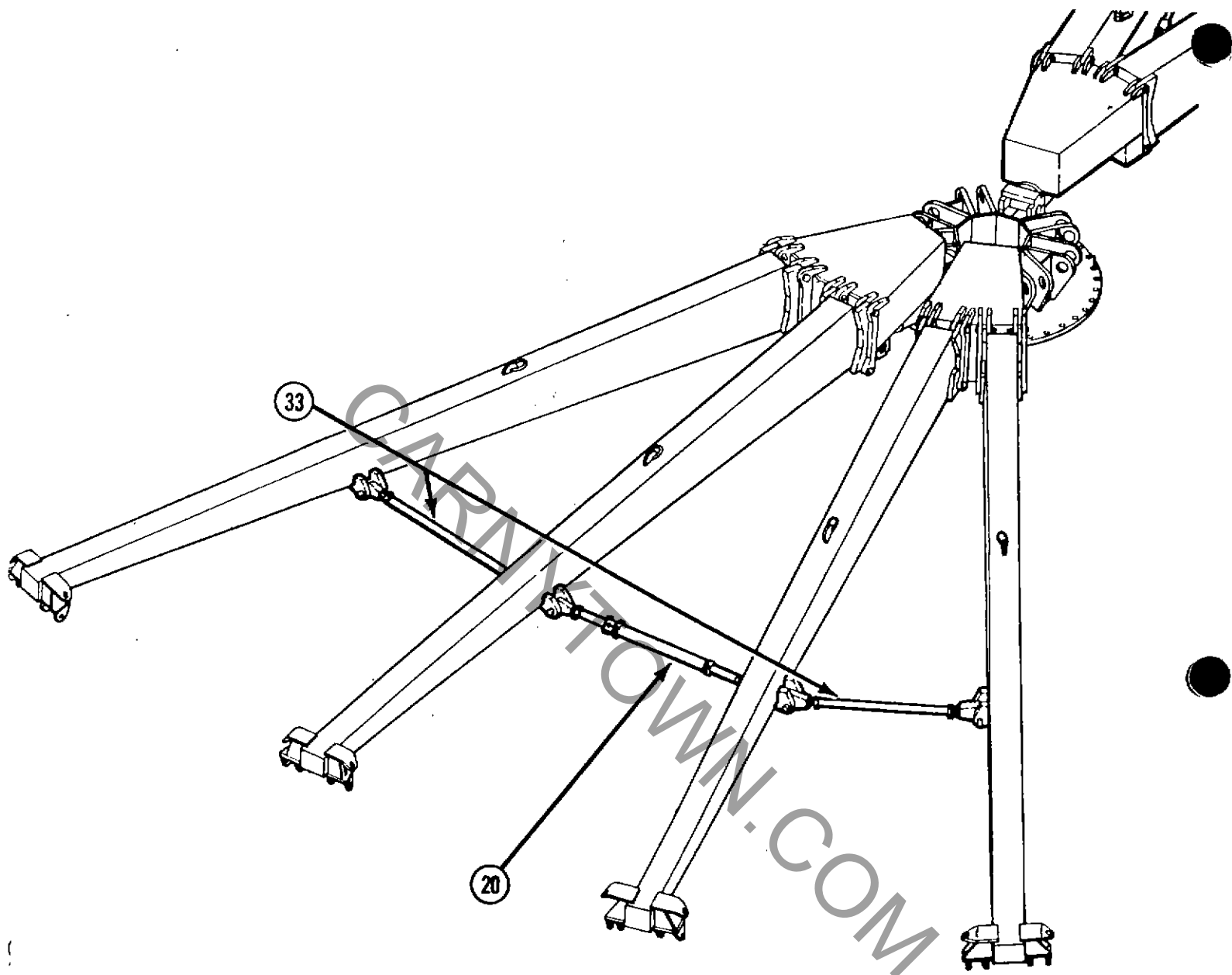

20. () Inspect spreader bars, attach points, and cross rods (Bulletins 837-0330-00).

33. () Inspect spreader bar adjustment (Bulletin 837-0251-0B).

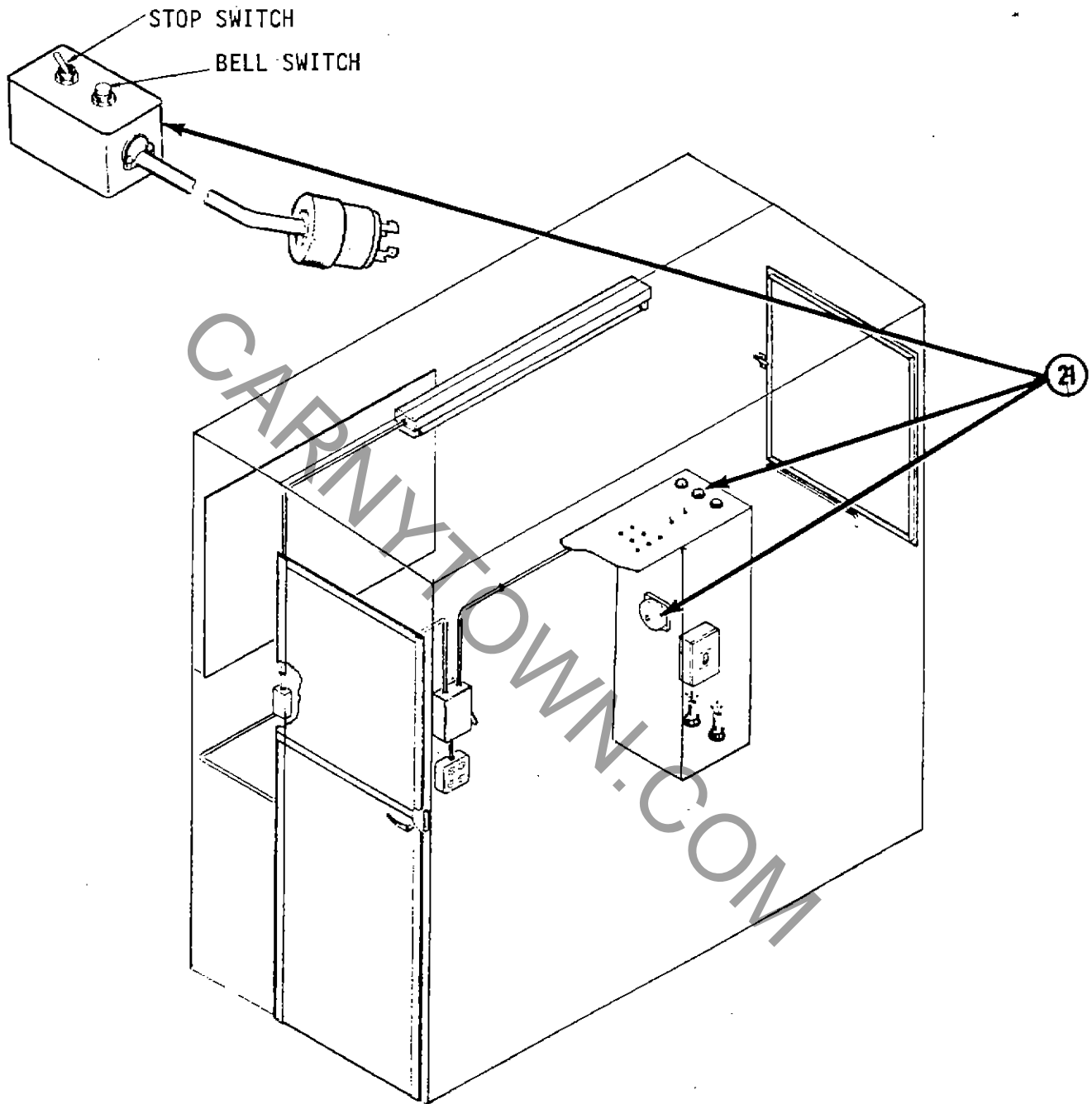

21. () Inspect operating controls, including the remote stop/bell switch and foot switch, if equipped. THE RIDE MUST HAVE TWO OPERATORS, one in the control house and one opposite (180°) on the platform.

CARNYTOWN.COM



NUMBER: B337R1092-0

DATE: FEB. 28, 1991

SUPERSEDES:

America's Largest Manufacturer of Amusement Rides

SERVICE BULLETIN

Effective Serial Number: All Units - Chance Manufacturing Co., Inc.

Chance Rides, Inc. SPECIFICALLY DISCLAIMS ANY LIABILITY for losses associated with rides produced by Chance Manufacturing Company, Inc.

Ride: FLYING BOBS

Subject: Load/Unload Safety Decal

Chance Rides, Inc. has become aware that the vehicles on the FLYING BOBS amusement ride may suddenly swing or shift while passengers are loading or unloading. This swing or shift is due to the passenger's weight on one side of the vehicle, placing the vehicle in an out-of-balance condition. ALL OPERATORS MUST VERBALLY CAUTION PERSONS OF POSSIBLE VEHICLE MOVEMENT AS THEY ENTER AND EXIT FROM THE VEHICLES.

A safety decal has been developed to help alert persons of possible vehicle movement as they enter and exit the vehicle. Chance Rides, Inc. requires all owner/operators of FLYING BOBS rides to order and install one of these safety decals on each of the vehicles. A total of 18 decals are required for one ride. Order part number 22198506 and install as shown on this bulletin.

Complete the attached Certification Of Compliance and return it to Chance Rides, Inc. within fifteen (15) days from the receipt of the decals.

All work must be performed by qualified personnel, capable of understanding the function of the parts and their proper installation.

NOTICE

Use only those components authorized, specified or provided by Chance Rides, Inc.

Chance Rides, Inc. SPECIFICALLY DISCLAIMS ANY LIABILITY for losses associated with any unauthorized alterations and/or modifications or additions and installations of unauthorized components.

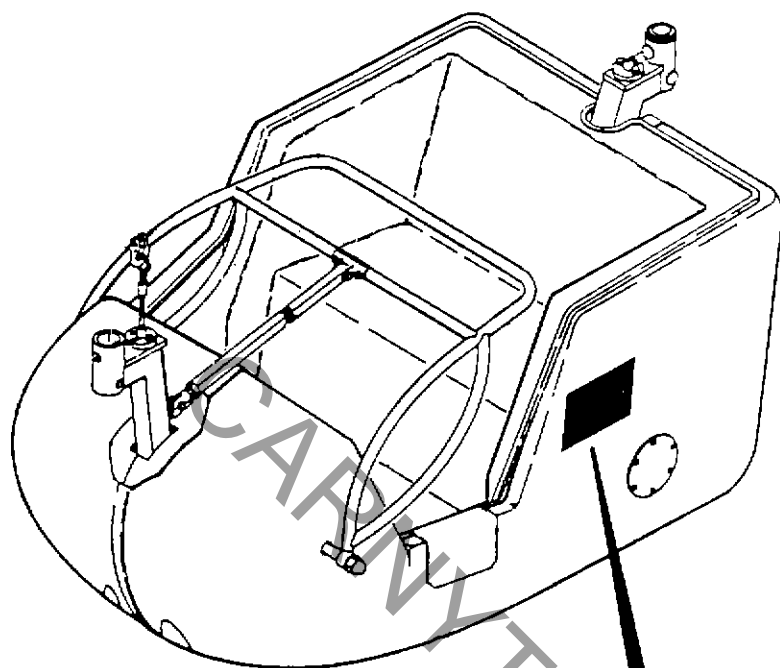

CAUTION

**VEHICLE MAY SWING
WHILE ENTERING
OR EXITING**



NUMBER: B337R1090-0

DATE: DEC. 15, 1990

SUPERSEDES:

America's Largest Manufacturer of Amusement Rides

SERVICE BULLETIN

Effective Serial Number: All Units - Chance Manufacturing Co., Inc.

Chance Rides, Inc. SPECIFICALLY DISCLAIMS ANY LIABILITY for losses associated with rides produced by Chance Manufacturing Company, Inc.

Ride: FLYING BOBS

Subject: Double Sweep Inspection

Chance Rides, Inc. requires all owners of FLYING BOBS amusement rides to inspect the double sweeps for cracks around the bearing housing support plates. Inspection must be done as shown in the illustration on this bulletin. If the plate cracks, failure of the part could occur, resulting in possible injury to passengers.

If any cracks are found, contact the Chance Rides Customer Service Department. DO NOT ATTEMPT TO REPAIR OR WELD. DO NOT OPERATE the ride until the Chance Rides, Inc. approved repair rework kit number K337R1090-0 has been properly installed. If no cracks are found during inspection, the kit is not required.

All work must be performed by qualified personnel, capable of understanding the function of the parts and their proper installation.

NOTICE

Use only those components authorized, specified or provided by Chance Rides, Inc.

Chance Rides, Inc. SPECIFICALLY DISCLAIMS ANY LIABILITY for losses associated with any unauthorized alterations and/or modifications or additions and installations of unauthorized components.

INSPECTION PROCEDURES

1. Thoroughly clean all areas to be inspected. All areas must be free of grease and other foreign materials which could hamper inspection.
2. Visually inspect all areas as indicated on the illustration below.
3. This inspection must be done every 30 days or at each set up, whichever occurs first.

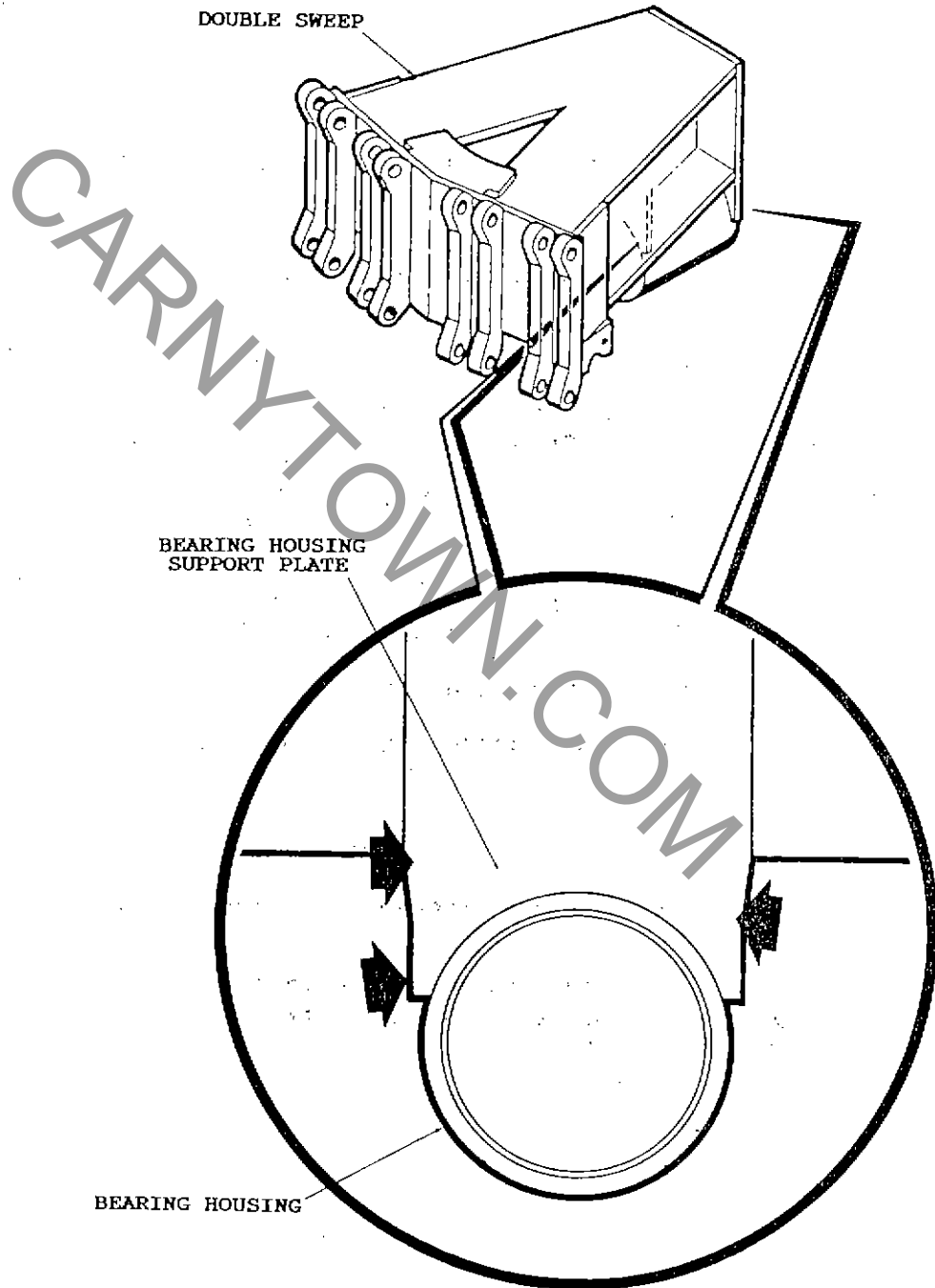



Number: B37-0337-00

Date: March 22, 1989

Supersedes:

America's Largest Manufacturer of Amusement Rides

SERVICE BULLETIN

Effective Serial Numbers: 71-2701 through 76-2732

Ride: FLYING BOBS

Subject: Vehicle Frame Pivot
Inspection and Repair

It has been determined by CHANCE MANUFACTURING CO. INC. that cracks can develop in the vehicle frames on early model FLYING BOBS.

The owner of the above noted FLYING BOBS amusement rides are therefore required to inspect their rides as described in this bulletin. Perform the inspection using the instructions on the reverse side of this bulletin. Return the Certification Of Compliance within 15 days from receipt of the bulletin.

The inspection must be performed by qualified personnel, capable of understanding the function of the parts and their proper installation. If there are any questions regarding the instructions or this inspection, contact the CHANCE CUSTOMER SERVICE DEPARTMENT.

Factory and Sales Office: 4219 Irving • P.O. Box 12328 • Wichita, Kansas 67277 • (316) 942-7411

INSPECTION PROCEDURE

Check the vehicle frame on each vehicle using the following procedure.

1. Remove the floor inspection cover from inside the vehicle.
2. Measure 23" down the centerline of the vehicle from the cover plate around the frame opening.
3. Make two marks, each one 2" to the side of the center as shown.
4. From the underside of the vehicle, cut two 2-1/2 inch diameter holes in the fiberglass, using the marks made in Step 2 as centers.

IMPORTANT: Be careful not to cut into the metal frame beneath the fiberglass.

5. Thoroughly clean the area and use a light to inspect the vehicle frame for cracks as shown. Use a mirror as required to see all sides of all parts. Inspect the top and both sides of the frame from inside the vehicle. Inspect the bottom and both sides of the frame through the holes in the fiberglass.

6. Check the operation of the frame pivot bearings. Look for excessive looseness or other signs of wear or damage to the bearings and/or frame.

7. Move the upper frame from side to side. Look for wear marks near the opening in the vehicle body, or excessive side-to-side movement, which indicates wear or damage to the bearings and/or frame.

THIS INSPECTION MUST BE PERFORMED AT LEAST TWICE EACH OPERATING SEASON.

If cracks or any unusual condition exist on any of the frames, contact the CHANCE CUSTOMER SERVICE DEPARTMENT immediately. DO NOT OPERATE THE RIDE.

CHECK FOR
SIDE-TO-SIDE
MOVEMENT

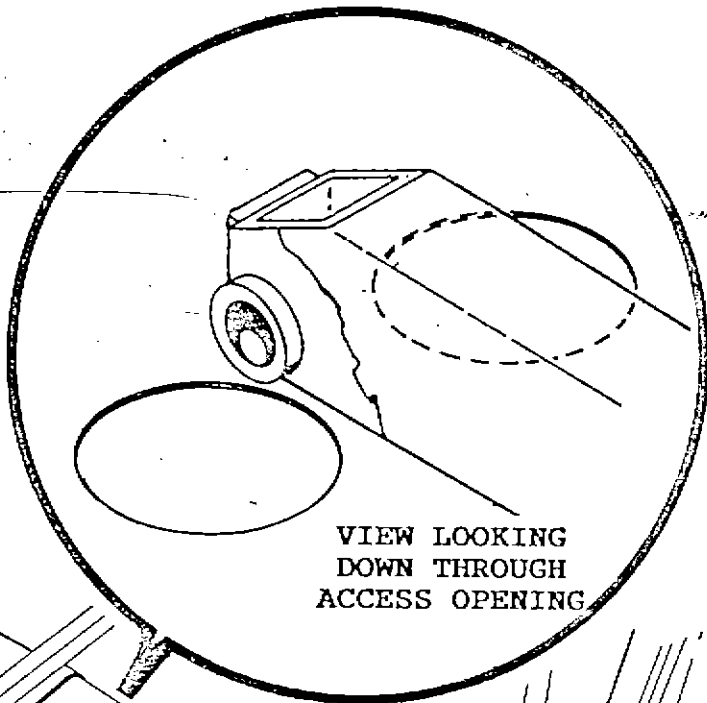

VIEW LOOKING
DOWN THROUGH
ACCESS OPENING

CHECK FOR
WEAR MARKS

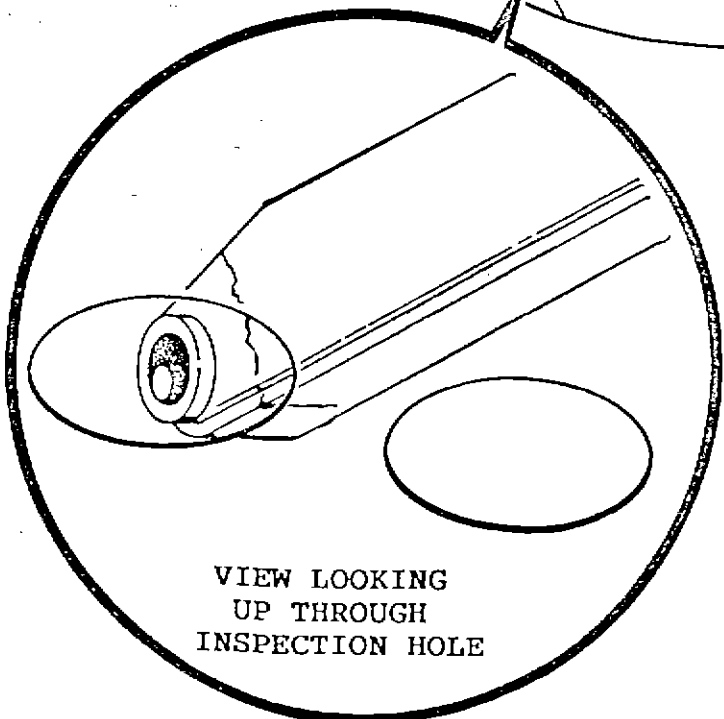
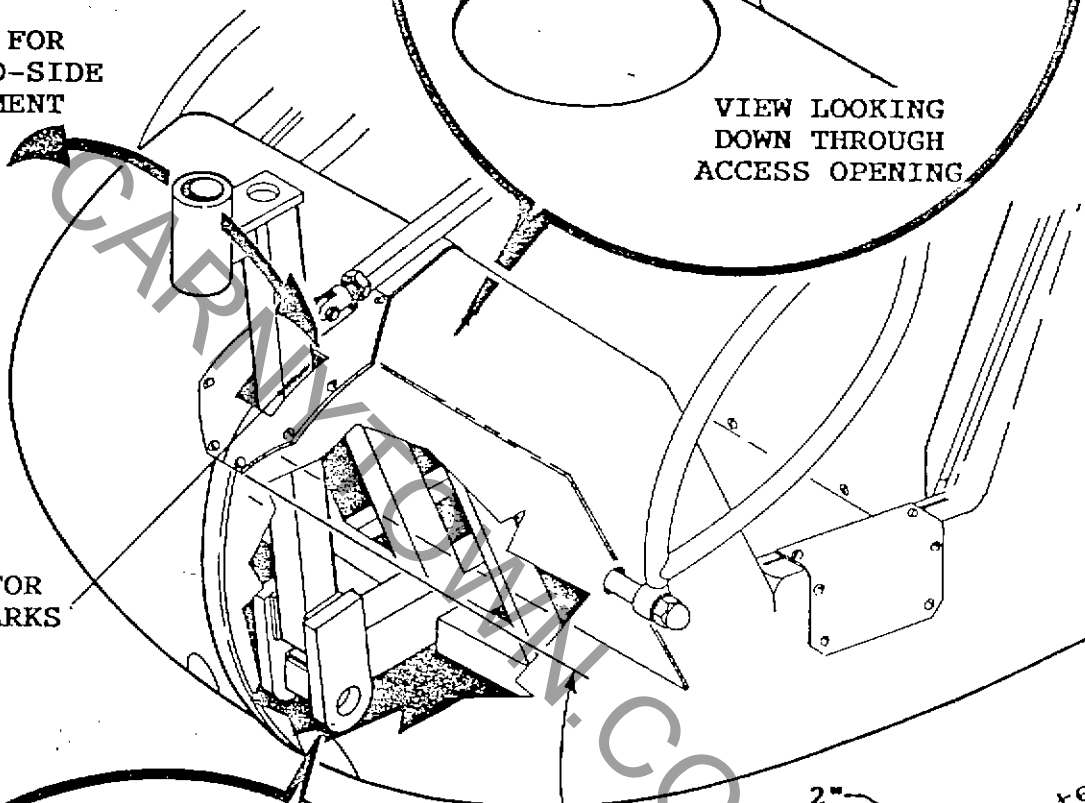

VIEW LOOKING
UP THROUGH
INSPECTION HOLE

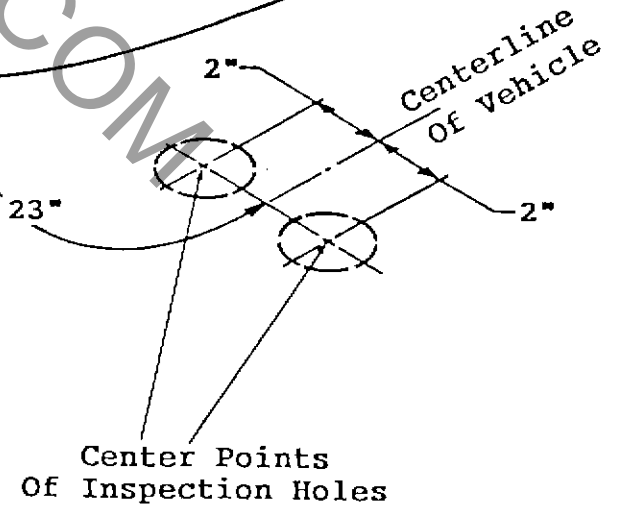

Center Points
Of Inspection Holes

CARNYTOWN.COM



Number: B37-0330-00

Date: Dec. 31, 1988

Supersedes:

America's Largest Manufacturer of Amusement Rides

SERVICE BULLETIN

Effective Serial Numbers: 71-2701 through 85-2766

Ride: FLYING BOBS/MUSIC FEST

Subject: Spreader Bar
Inspection and Rework



WARNING: FAILURE TO COMPLY WITH THIS SERVICE BULLETIN CAN RESULT IN FAILURE OF THE SPREADER BAR SYSTEM AND INJURY TO PASSENGERS.

CHANCE MANUFACTURING CO., INC. has developed a new spreader bar system which provides longer life of the spreader bars, sweeps and center hub, and increased passenger safety.

ALL OWNERS OF THE ABOVE NOTED FLYING BOBS AND/OR MUSIC FEST AMUSEMENT RIDES ARE REQUIRED TO PERFORM THE INSPECTION AND APPROPRIATE REWORK TO UPDATE THEIR SPREADER BARS TO THE NEW DESIGN.

Perform the inspection as described on the following pages of this bulletin to determine the necessary rework required for your ride. Order the appropriate rework kit(s) listed on the following pages of this bulletin, depending upon the configuration of your ride:

Install the kit(s) using the instructions provided with each kit. All work must be performed by competent, qualified mechanics, capable of understanding the function of the parts and their proper installation.

Fill out the attached Certification Of Compliance for the inspection and the rework within fifteen (15) days of receipt of this bulletin. If there are any questions regarding the instructions or this repair, contact the CHANCE CUSTOMER SERVICE DEPARTMENT.

Factory and Sales Office: 4219 Irving • P.O. Box 12328 • Wichita, Kansas 67277 • (316) 942-7411

INSPECTION PROCEDURE

Inspect the spreader bar system on your ride, comparing it to the illustrations on the following pages.

EQUAL LENGTH SPREADER BARS

If your ride has equal length spreader bars and a spring-loaded spreader bar as shown in the illustration on the opposite page, you must replace the spring-loaded spreader bar. Order the following kit:

SPRING-LOADED SPREADER BAR REWORK KIT No. K37-0330-01
(consists of these parts necessary for one complete ride)

PARTS LIST

<u>Item</u>	<u>Part No.</u>	<u>Description</u>	<u>Qty.</u>
1	376-0399700	SPRING SPREADER BAR ASSEMBLY (392-201A005) . . .	1
	376-7189900	..Spring Loaded Spreader Bar (392-210-001) . . .	1
	237-0444200	..Rod End	2
	691-4764600	..Jam Nut (1-1/4-12)	2
2	390-5230000	TAPER PIN - 3/4 x 5-11/16" (CSN10A05-07)	2
3	694-5190200	HAIRPIN - 5/32"	2
4	B37-0251-0B	BULLETIN - Spreader Bar Instructions	1

IMPORTANT: The new rod ends provided with the kit are of a new design and do not require bushings. DO NOT USE THE OLD ROD ENDS WITH THE NEW SPRING-LOADED SPREADER BAR. Discard the old rod ends.

INSPECTION PROCEDURE (continued)

EQUAL LENGTH SPREADER BARS

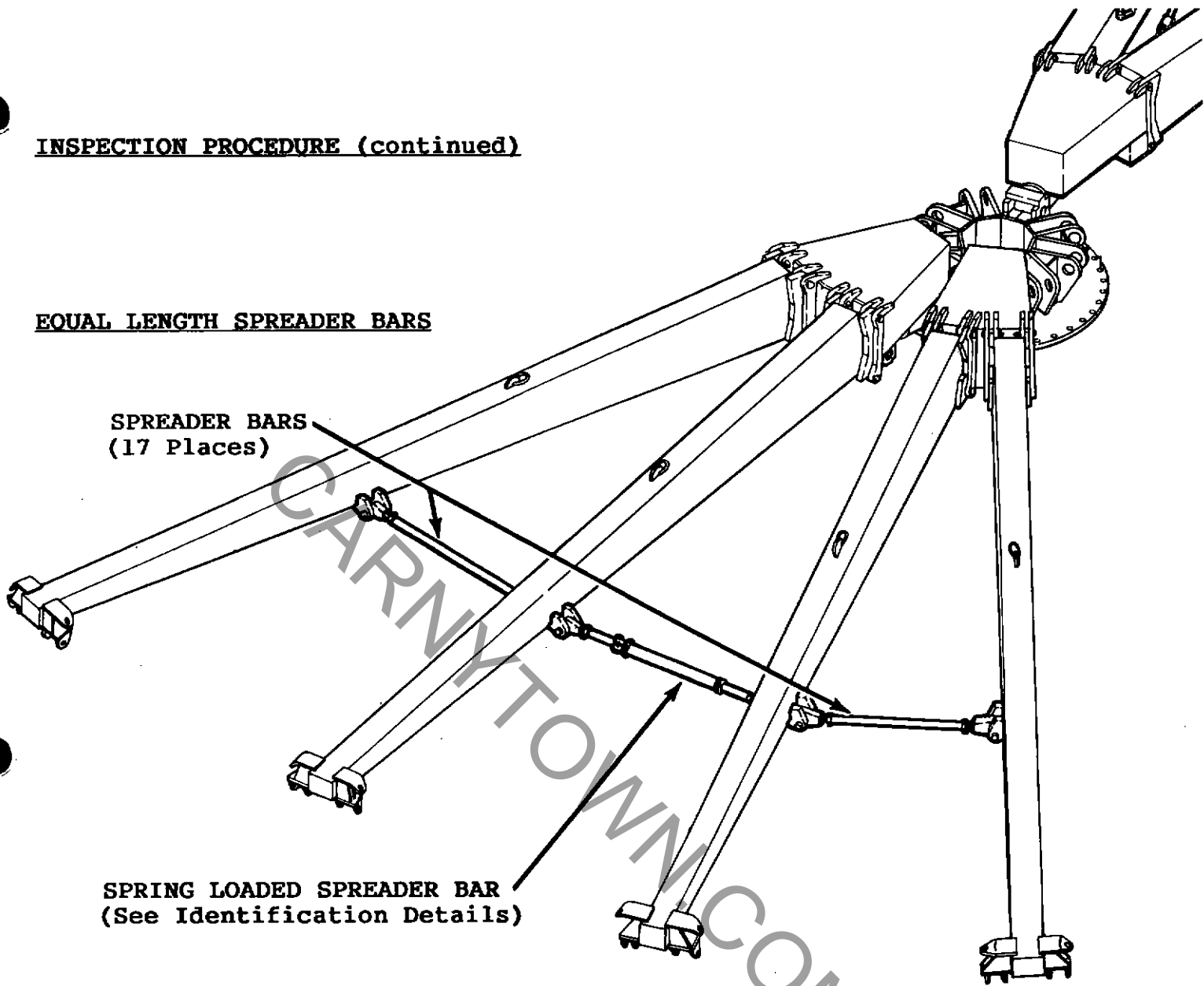

NEW STYLE
SPRING-LOADED SPREADER BAR

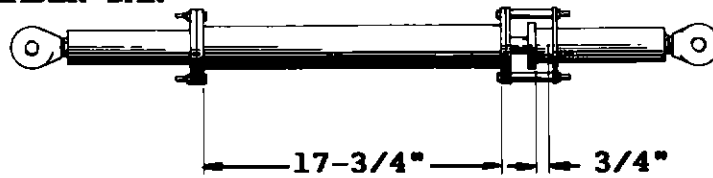

OLD STYLE
SPRING LOADED SPREADER BAR

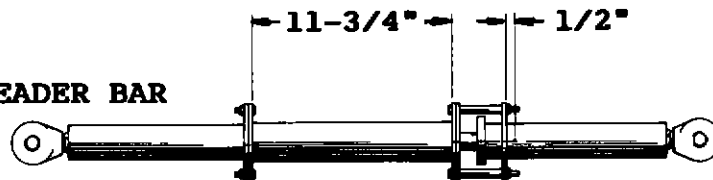

INSPECTION PROCEDURE (continued)

UNEQUAL LENGTH SPREADER BARS

If your ride has unequal length spreader bars as shown in the above illustration, you must replace the entire spreader bar system. Order the following kit:

SPREADER BAR SYSTEM REWORK KIT No. K37-0330-02
(consists of these parts necessary for one complete ride)

PARTS LIST

<u>Item</u>	<u>Part No.</u>	<u>Description</u>	<u>Qty.</u>
1	376-0399600	SOLID SPREADER BAR ASSEMBLY (392-201A004)	17
	337-4162300	..Spreader Bar (337-598-001)	1
	237-0444200	..Rod End	2
	691-4764600	..Jam Nut (1-1/4-12)	2
2	376-0399700	SPRING SPREADER BAR ASSEMBLY (392-201A005)	1
	376-7189900	..Spring Loaded Spreader Bar (392-210-001)	1
	237-0444200	..Rod End	2
	691-4764600	..Jam Nut (1-1/4-12)	2
3	390-5230000	TAPER PIN - 3/4 x 5-11/16" (CSN10A05-07)	2
4	694-5190200	HAIRPIN - 5/32"	2
5	B37-0251-0B	BULLETIN - Spreader Bar Instructions	1

IMPORTANT: The new rod ends provided with the kit are of a new design and do not require bushings. DO NOT USE THE OLD ROD ENDS WITH THE NEW SPREADER BAR. Discard the old rod ends.

INSPECTION PROCEDURE (continued)

UNEQUAL LENGTH SPREADER BARS

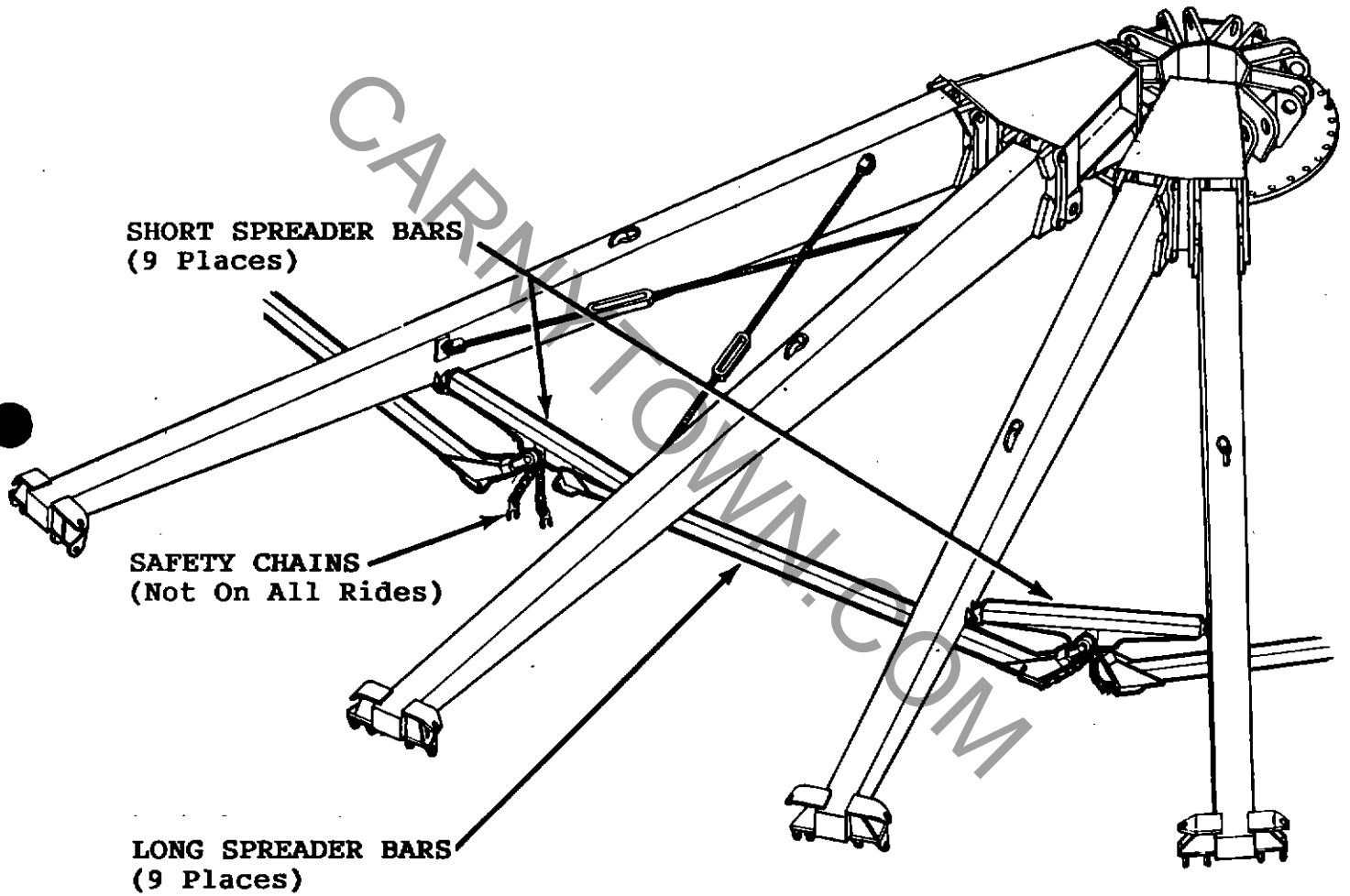

INSPECTION PROCEDURE (continued)

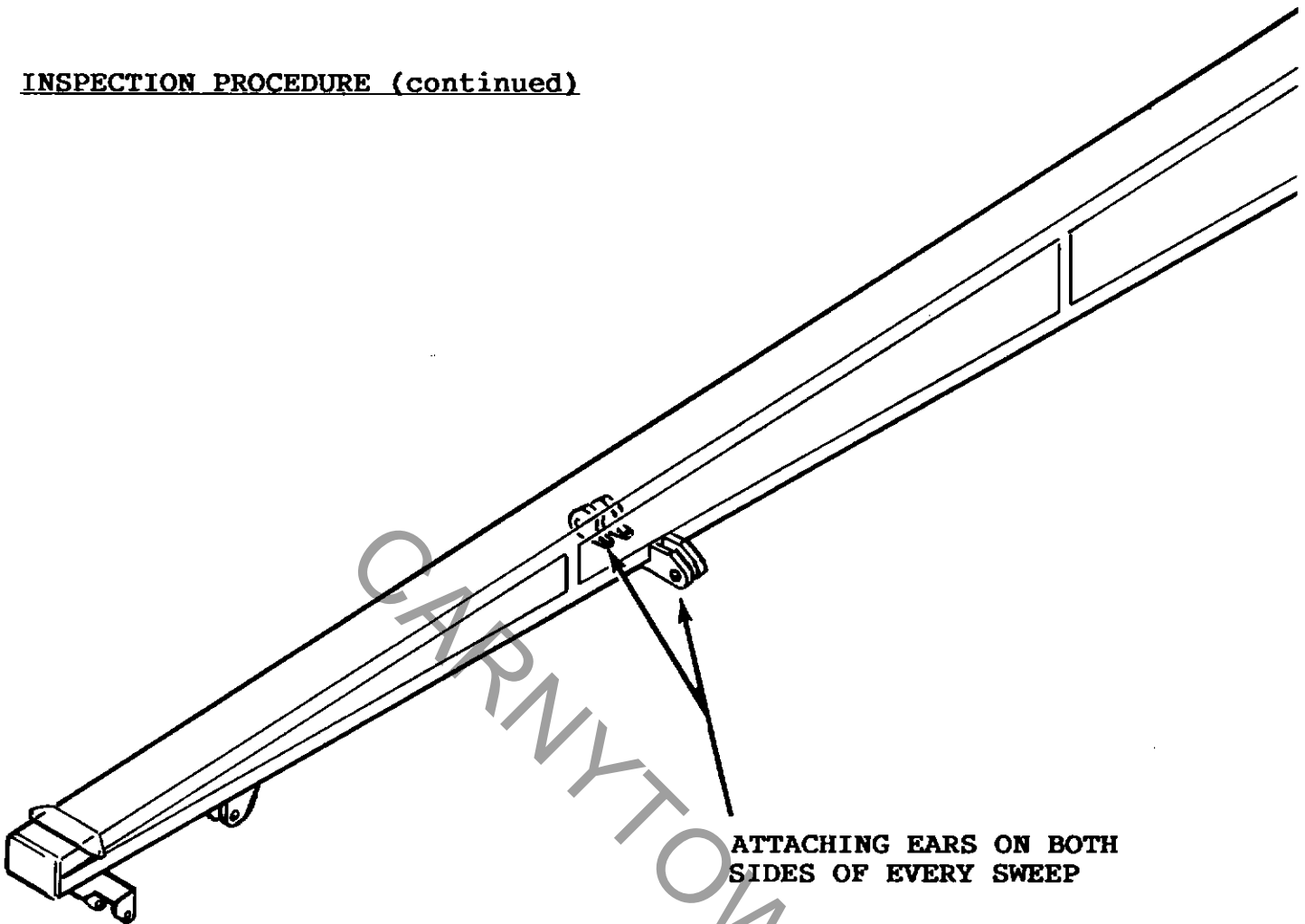

If your ride does not have a spreader bar attaching ear on both sides of every sweep, you must install the remaining ears before replacing the spreader bar system. Order the following kit:

SPREADER BAR ATTACHING EAR KIT No. K37-0333-00
(consists of these parts necessary for one complete ride)

PARTS LIST

<u>Item</u>	<u>Part No.</u>	<u>Description</u>	<u>Qty.</u>
1	376-4237400	EAR AND BUSHING WELDMENT-R.H.(392-565-001) . . .	9
2	376-4237500	EAR AND BUSHING WELDMENT-L.H.(392-565-002) . . .	9
3	376-2737500	TOOL - Alignment (392-566-001)	1
4	---	INSTALLATION INSTRUCTIONS	1



Number: B37-0318-00

Date: March 21, 1988

Supersedes:

America's Largest Manufacturer of Amusement Rides

SERVICE BULLETIN

Effective Serial Numbers: 71-2701 through 85-2766

Ride: FLYING BOBS / MUSIC FEST

Subject: Master Sweep Bearing
Cap Rework (Capscrews)

As a safety precaution, CHANCE MANUFACTURING CO., INC. requires that the owners of FLYING BOBS and MUSIC FEST amusement rides with the above noted serial numbers perform the modification described in this bulletin. This modification will provide improved retention of the master sweep bearings in the center hub.

Order kit number K76-0317-00, which includes all necessary parts and hardware for one complete ride. Install the kit using the instructions provided on the following pages of this bulletin. Fill out the attached Certification Of Compliance for the installation within 15 days of receipt of the kit.

PARTS LIST

Kit Number K76-0317-00 Master Sweep Bearing Cap Rework

<u>Item No.</u>	<u>Quantity</u>	<u>Part Number</u>	<u>Description</u>
1	1	376-31703	Drill Guide (K76-0317-01)
2	4	686-09831	Capscrew - 7/8-9 x 4-1/2" (Grade 8)
3	4	376-85568	Hardened Washer - Special (K76-0317-02)
4	1	---	Tap (7/8-9 Thread)
5	3	686-09512	Bolt - 3/4-10 x 1-1/2"
6	3	686-10226	Bolt - 7/8-9 x 1-1/2"
7	1	---	Drill Bit (49/64" Diameter)
8	1	---	Drill Bit (29/32" Diameter)

Factory and Sales Office: 4219 Irving • P.O. Box 12328 • Wichita, Kansas 67277 • (316) 942-7411

INSTALLATION INSTRUCTIONS

1. Use the chain hoist to remove the two sweeps from the master sweep.
2. Using the hoist to support the weight of the master sweep, remove the four 3/4-10 bolts from the bearing caps. Remove the cap and move the master sweep out of the way.

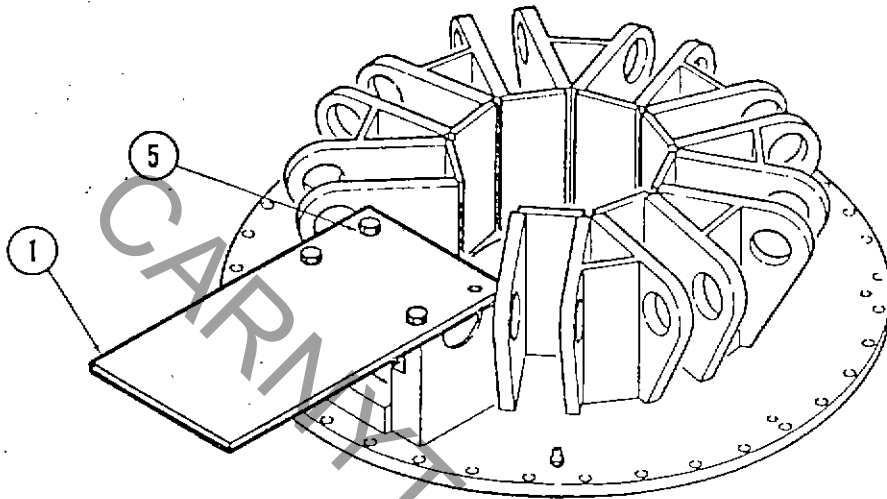

3. Use three 3/4-10 x 1-1/2" bolts (Item #5) to mount the drill guide (Item #1) to the bearing blocks on the center hub as shown.

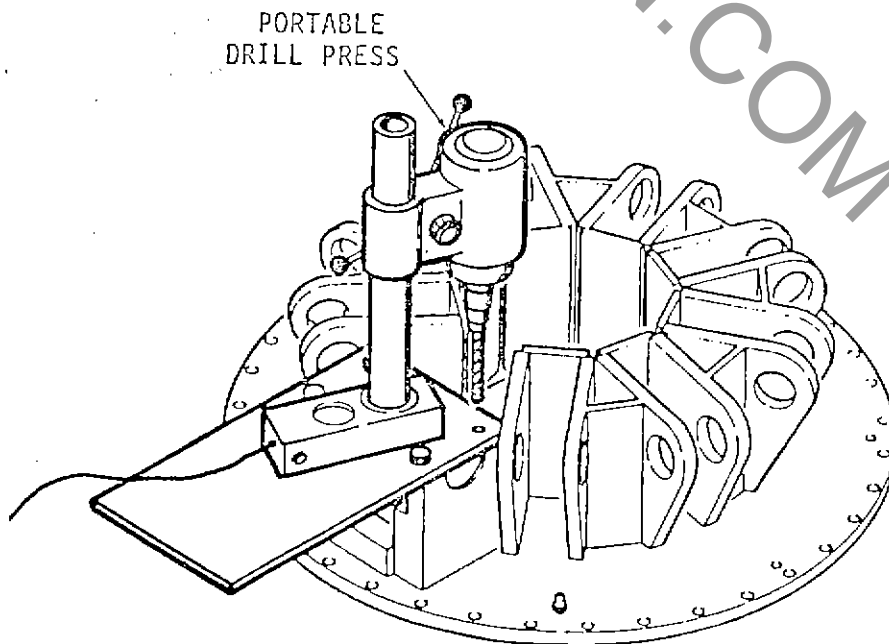

4. Using a 1-1/4" capacity portable drill press with a magnetic base, locate the drill exactly over the existing threaded hole. Drill the hole to 49/64" diameter, 3" deep, using the bit provided (Item #7). DO NOT USE A HAND-HELD DRILL MOTOR.

5. Tap the hole to 7/8-9, 2-1/2" deep using the tap provided (Item #4). Install a 7/8-9 x 1-1/2" bolt. (Item #6).
6. Remove the next 3/4-10 bolt and repeat Steps 4 and 5 on that hole.
7. Repeat Steps 4, 5 and 6 until all four holes have been drilled and tapped to 7/8-9.
8. Remove the capscrews and the drilling guide.
9. Drill the four holes in the bearing cap to 29/32" diameter, using a drill press and the drill bit provided (Item #8). DO NOT USE A HAND HELD DRILL MOTOR.

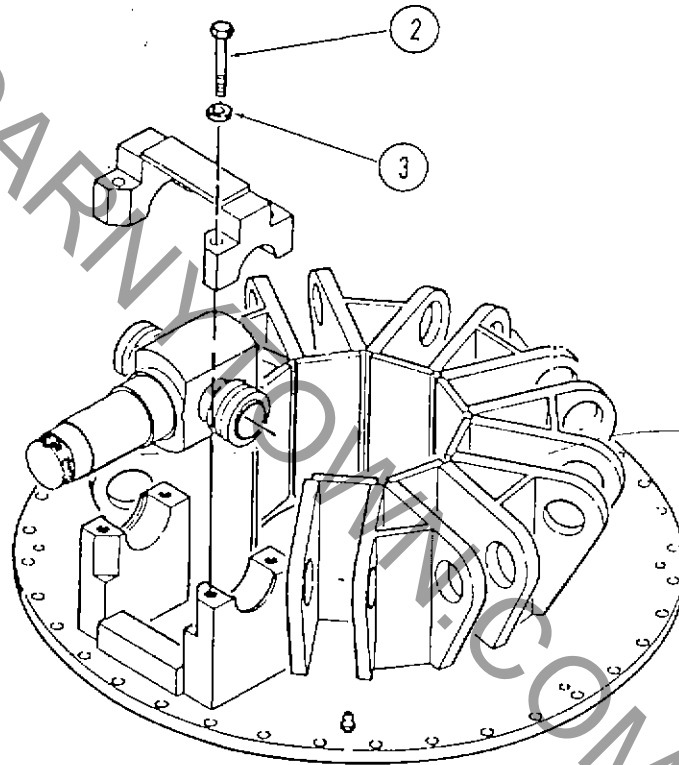

10. Install the master sweep and bearing cap using the 7/8-9 capscrews (Item #2) with the special hardened flatwashers (Item #3) under the heads. Tighten the capscrew to 460 ft-lbs. torque.
11. Reassemble the sweeps to the master sweep.
12. Check the torque of the capscrews at weekly intervals or at every set-up, whichever occurs first.

CARNYTOWN.COM



Number: B37-0294-00

Date: March 25, 1987

Supersedes:

America's Largest Manufacturer of Amusement Rides

SERVICE BULLETIN

Effective Serial Numbers:

All Units

Ride:

FLYING BOBS / MUSIC FEST

Subject:

Retainer For Upper Inner Scenery Panels

As a safety precaution, CHANCE MANUFACTURING CO., INC. requires that all FLYING BOBS and MUSIC FEST amusement rides be equipped with retainers for the upper inner scenery panels. These retainers ensure that the panels stay in place during operation of the ride.

If your ride is not already equipped with these retainers, order the Retainer Kit, part number K37-0294-00 within ninety (90) days of the issue date of this bulletin. The kit includes all necessary parts for one complete ride.

NOTE: The kits will be billed at our manufacturing cost during this ninety day time period.

Install the kit using the instructions on the reverse side of this bulletin. If you have any questions regarding this kit or its installation, contact the CHANCE CUSTOMER SERVICE DEPARTMENT.

PARTS LIST

Kit K37-0294-00 RETAINER KIT consists of the following parts:

<u>Part Number</u>	<u>Description</u>	<u>Quantity</u>
337-74210	RETAINER CLIP (337-975-001)	20
390-52285	PIN - Tapered 3/8x4-3/16 (CSN10A02-02) .	20
694-51897	HAIRPIN - 3/32	20

Factory and Sales Office: 4219 Irving • P.O. Box 12328 • Wichita, Kansas 67277 • (316) 942-7411

1987
1987
1987
1987
1987
1987

Installation Instructions

All work must be performed by competent mechanics, capable of understanding the function of the parts and their proper installation.

Read these instructions thoroughly and make sure you understand them before installing the kit.



WARNING: Do not drill into the truss until ALL POWER TO THE RIDE IS OFF. A serious electrical shock hazard can result.

1. With the light posts and scenery panels in place, locate the retainer clip on the truss as shown.
2. Using the retainer as a drill guide, drill a 25/64" hole through only one side of the truss.

NOTE: TO AVOID DAMAGE TO THE WIRING INSIDE THE TRUSS, STOP THE DRILL AS SOON AS THE BIT IS THROUGH THE TUBING WALL.

3. Without moving the retainer, drill from the other side until the bit is through the tubing wall.
4. Install the pin and hairpin, being careful of any wiring inside the truss.
5. Repeat Steps 1 through 4 on the remaining trusses.

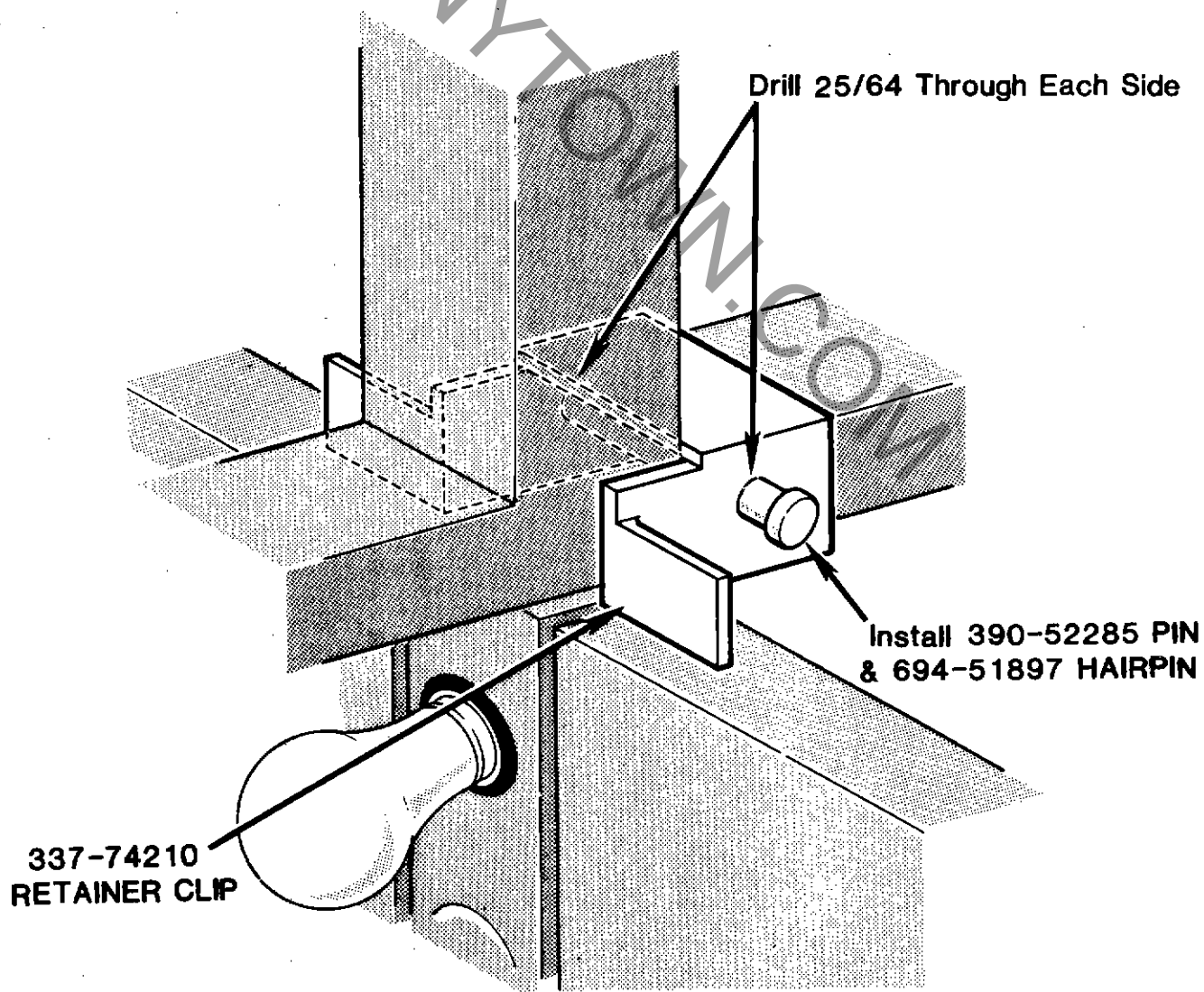



Number: B37-0251-0B

Date: Dec. 31, 1988

Supersedes: B37-0251-00
(2-24-84)
A37-0251-0A
(6-30-86)

America's Largest Manufacturer of Amusement Rides

SERVICE BULLETIN

All Units Which Have Been Reworked To Comply
Effective Serial Numbers: With Service Bulletin B37-0330-00 or B76-0332-00.

Ride: FLYING BOBS/MUSIC FEST/
THUNDERBOLT

Subject: Installation, Inspection And
Adjustment Of Spreader Bars

Service Bulletin Number B37-0251-00 and Safety Alert Bulletin Number A37-0251-0A are superseded by this Service Bulletin. They are no longer in effect and should be destroyed.

CHANCE MANUFACTURING CO., INC. wishes to emphasize the importance of the spreader bars on FLYING BOBS, MUSIC FEST and THUNDERBOLT amusement rides. Worn, damaged or improperly adjusted spreader bars can cause damage to the sweeps, spreader bars and center hub, and cause rough operation, which can result in injury to passengers.

READ THESE INSTRUCTIONS THOROUGHLY AND BECOME FAMILIAR WITH THE ENTIRE PROCEDURE. All work must be performed by competent, qualified mechanics, capable of understanding the function of the parts and their proper installation.

Complete the spreader bar inspection, installation and adjustment procedure using the instructions on the following pages of this bulletin. If you have any questions regarding the instructions or this procedure, contact the CHANCE CUSTOMER SERVICE DEPARTMENT.

Factory and Sales Office: 4219 Irving • P.O. Box 12328 • Wichita, Kansas 67277 • (316) 942-7411

INSPECTION OF SPREADER BARS AND ATTACHING EARS

Before adjusting the spreader bars, inspect all spreader bars and their attaching ears for cracks or bends. Inspect the spreader bar rod ends and the bushings in the attaching ears for wear or damage, and replace if necessary. Check the condition of all pins and hairpins.

DO NOT OPERATE THE RIDE WITH QUESTIONABLE SPREADER BARS.

IMPORTANT: Do not attempt to repair spreader bars in the field. Any spreader bar which has been welded, drilled, or otherwise repaired must be discarded and replaced with a new part.

SPREADER BAR INSTALLATION AND ADJUSTMENT PROCEDURE

1. With all spreader bars removed from the ride, including the spring loaded spreader bar, loosen all jam nuts (two on each spreader bar).

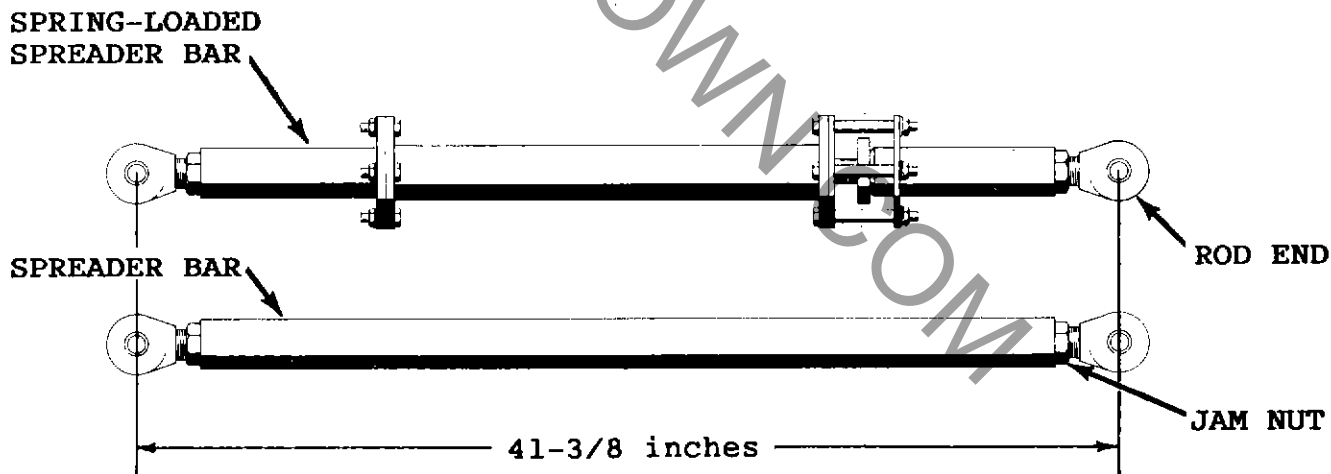

2. Measure the length between the rod ends, center-to-center, on all spreader bars, including the spring-loaded spreader bar. This measurement must be 41-3/8 inches. Adjust the rod ends, but do not tighten the jam nuts at this point. **THIS LENGTH IS USED AS A "BASE-LINE" MEASUREMENT ONLY, AND MUST BE ADJUSTED AS REQUIRED IN THE FOLLOWING STEPS.**

IMPORTANT: Both rod ends must be threaded into the spreader bars an equal number of turns. Always adjust both rod ends equally, within one-half turn.

3. Install the spreader bars on the ride, using the correct pins and hairpins.

NOTE: The spring-loaded spreader bar must be installed 180° from the master sweep (driving sweep).

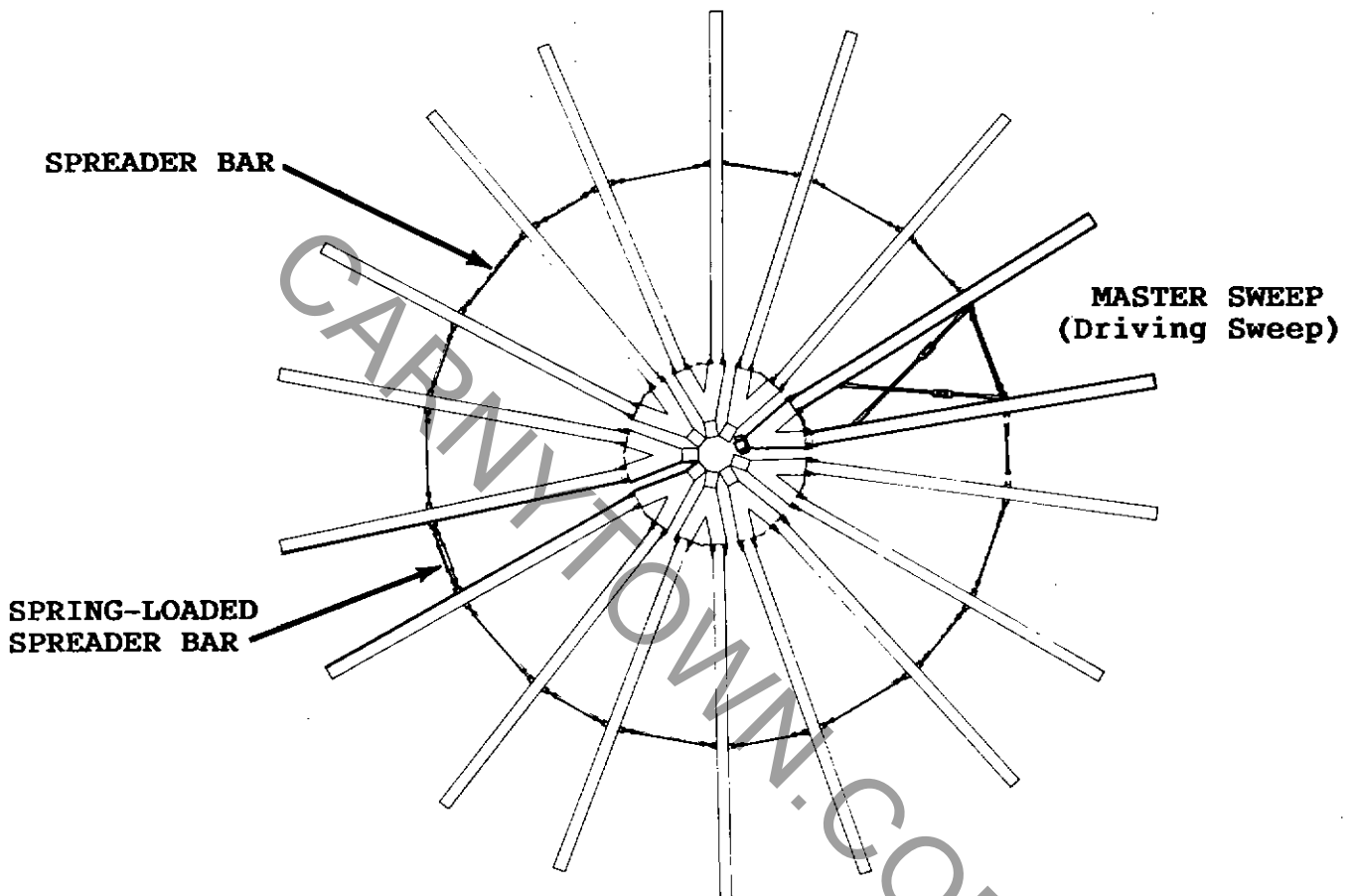

4. The vehicles must be installed to properly adjust the spreader bars. If the vehicles are not on the ride, install them at this time.

5. Rotate the ride counter-clockwise at least one complete revolution by hand, using two or three men.

NOTE: Open the hand valve on the hydraulic motor for ease of turning.

As the ride turns, watch the indicator ring on the spring-loaded spreader bar, as the spreader bar extends and retracts. The indicator ring must travel the same distance from "neutral" in both directions.

NEUTRAL POSITION

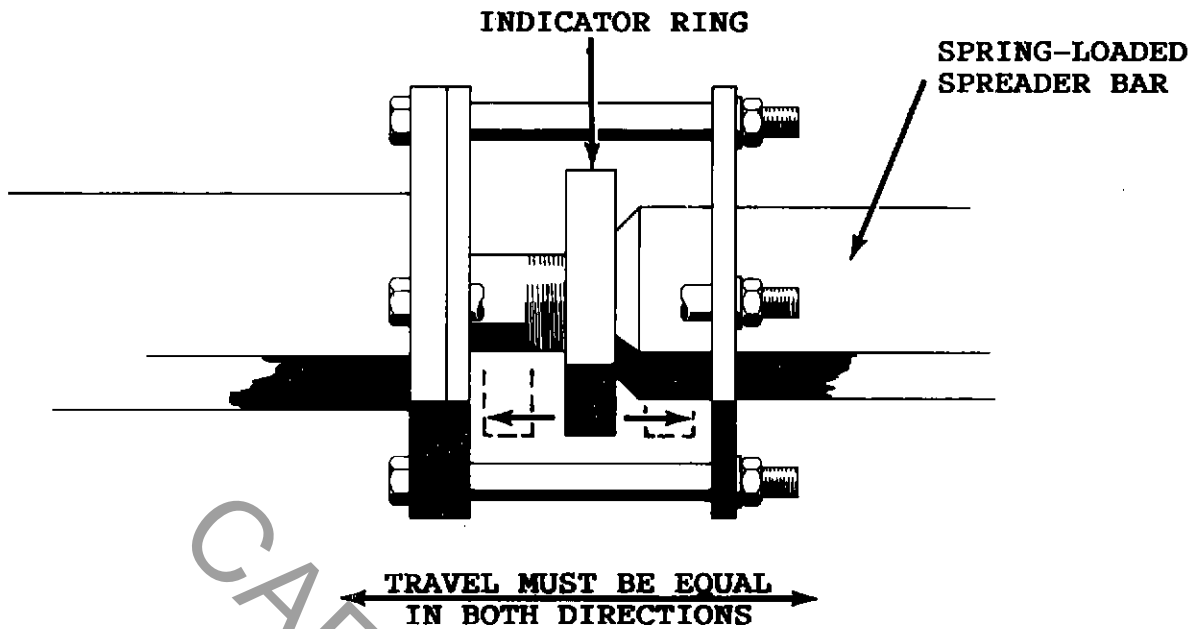

6. If the travel is equal in both directions, tighten the jam nuts on all spreader bars.

If the travel is not equal in both directions, adjust the length of each spreader bar (either longer or shorter) by turning the rod ends. **ALL SPREADER BARS, INCLUDING THE SPRING-LOADED SPREADER BAR, MUST BE THE SAME LENGTH.** If one spreader bar is adjusted to a longer length, **ALL** spreader bars must be lengthened by the same amount.

Repeat Steps 5 and 6 until the travel is equal.

7. As a final check, get into the vehicle closest to the spring-loaded spreader bar. Observe the action of the spring-loaded spreader bar during normal ride operation, at both low and high speeds. If the indicator ring travel is equal in both directions, the adjustment is satisfactory.

8. Permanently mark all sweeps so that they can be installed in the same location every time the ride is set up.

9. Check the spreader bar adjustment monthly, or at every set-up, using the observation procedure in Step 7.



Number:A37-0250-00

Date:2-25-84

Supersedes:

America's Largest Manufacturer of Amusement Rides

SAFETY ALERT

Effective Serial Numbers: All Units

Ride: FLYING BOBS / MUSIC FEST

Subject: Center Hub, Spindle and Spreader
Bar Inspection

CHANCE MANUFACTURING CO., INC. has recently become aware of a condition on one Flying Bobs ride which could have resulted in an accident. If operation of the ride had been continued, the sweeps could have lowered, causing the cars to contact the floor sections.

A crack developed in the center hub base plate near the point at which the spindle ears are welded. This condition was the result of one or more of the following:

- Incorrect replacement parts being installed
- Incorrect assembly during normal maintenance of the center hub
- Incorrect adjustment of the spreader bars

All owners of FLYING BOBS or MUSIC FEST rides are required to inspect the areas described in this Safety Alert bulletin and report any unusual conditions to CHANCE MANUFACTURING immediately. The attached Certification of Compliance must be completed and returned to CHANCE MANUFACTURING within seven (7) days of receipt of this Safety Alert bulletin.

INSPECTION PROCEDURE

The following inspection procedure is divided into five areas: Sweep Spindles, Spindle Ears, Center Hub Base Plate, Center Hub Bolts and Spreader Bars. Follow these instructions and repeat each step of the procedure for each sweep.

All work must be done by a competent, qualified mechanic capable of understanding the function of the parts and their correct installation.

1. SWEEP SPINDLES

- a. Inspect the six capscrews in each spindle for correct length. If the capscrews are too long, grind them flush with the surface of the clamp ring. (See Figure 1)

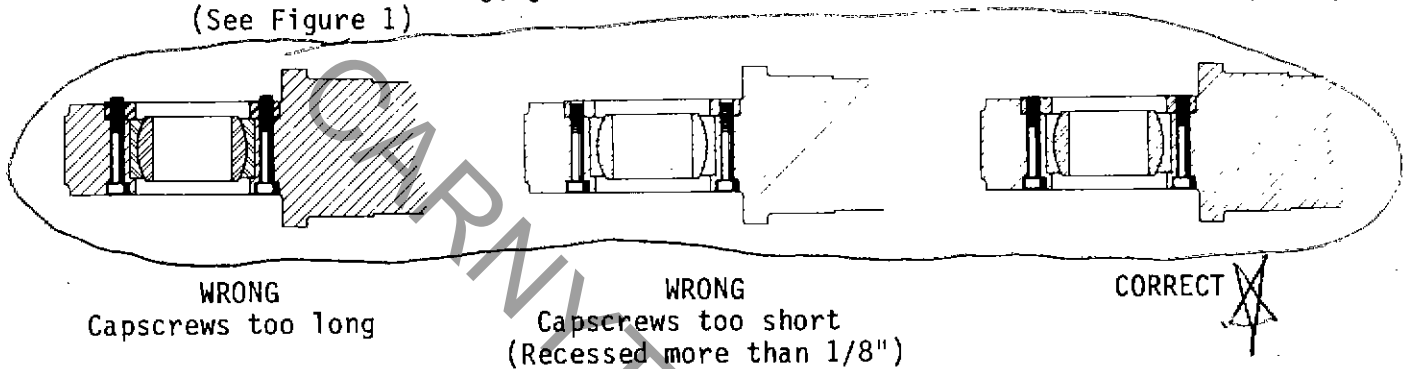

FIGURE 1

- b. Check the location of the spacer. The spacer must be installed on the side of the spindle opposite the large end of the retainer shaft as shown in Figure 2.

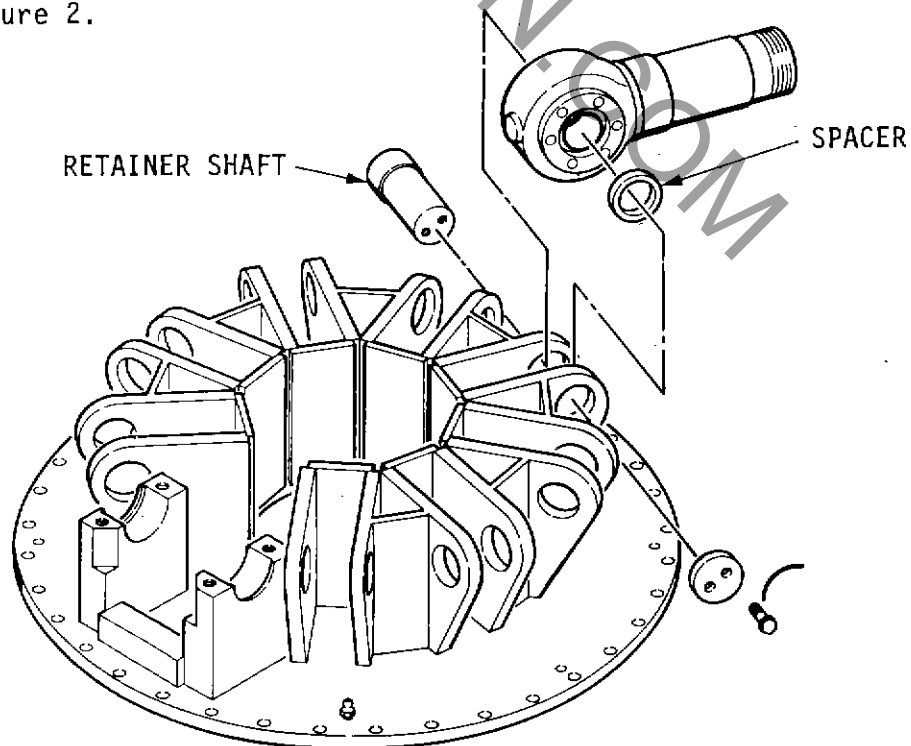

FIGURE 2

2. SPINDLE EARS - Inspect the inside surfaces of all spindle ears for circular gouges as shown in Figure 3.

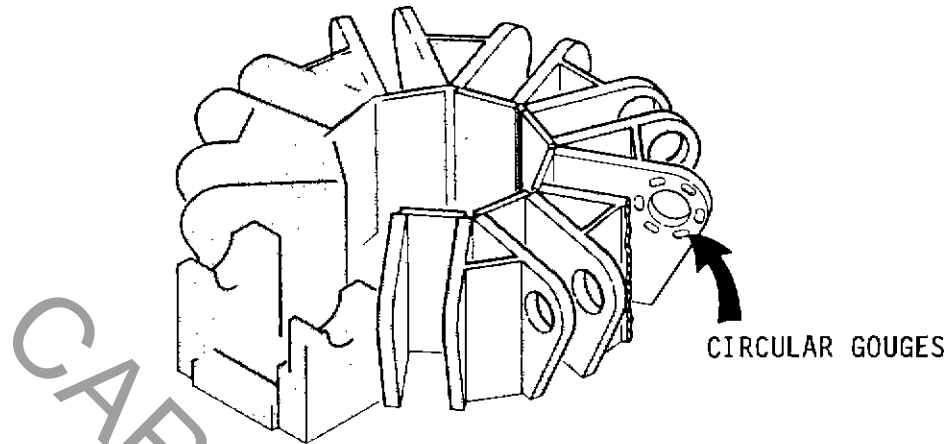

FIGURE 3

3. CENTER HUB BASE PLATE - Inspect the center hub base plate for cracks near the point at which the spindle ears are welded (See Figure 4).

IMPORTANT: Do not attempt to repair the center hub. If the center hub has been welded, drilled or otherwise repaired, contact CHANCE MANUFACTURING for further instructions

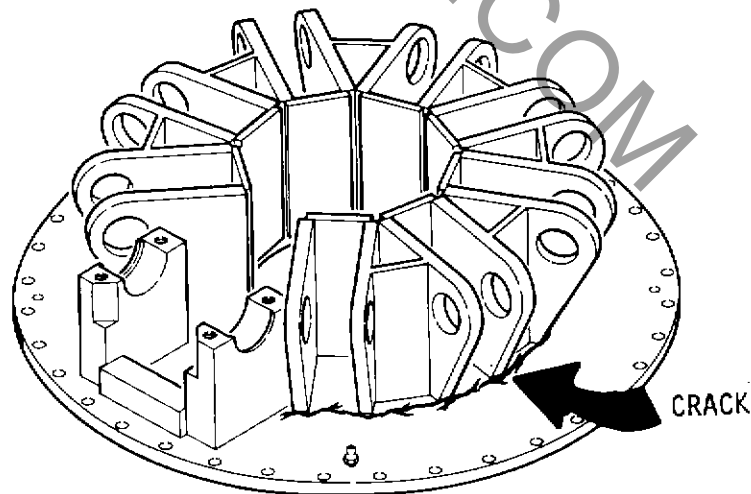
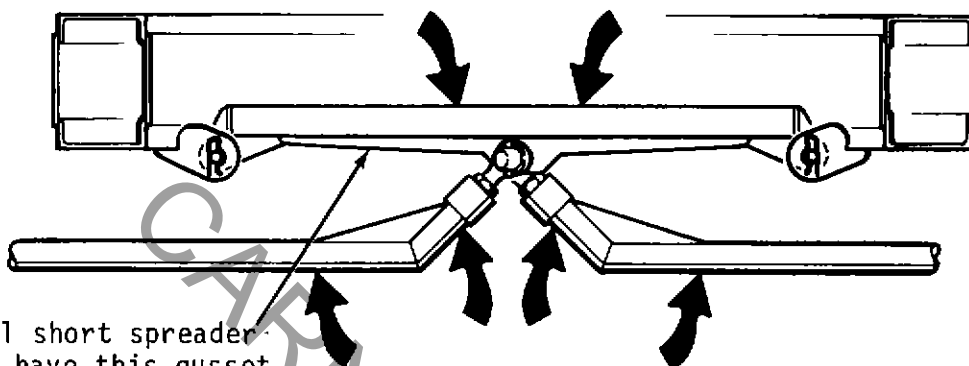

FIGURE 4

4. CENTER HUB BOLTS - Check the grade, condition and torque of the bolts which attach the center hub to the main hub bearing (Refer to Service Bulletin B37-0143-0B).

5. SPREADER BARS

- a. Inspect the spreader bars for cracks or bends. On rides with unequal length spreader bars, inspect for cracks in the areas shown in Figure 5. Also check spreader bar attaching points for worn bushings and pins



NOTE: All short spreader bars must have this gusset

FIGURE 5

IMPORTANT: Do not attempt to repair spreader bars in the field. ANY spreader bar which has been welded, drilled or otherwise repaired must be discarded and replaced with a new part.

- b. Check the adjustment of all spreader bars (Refer to Service Bulletin B37-0251-00)



Number: 140

Date: 8-8-77

Supersedes: #68/3-22-74

#126/6-29-76

America's Largest Manufacturer of Amusement Rides

SERVICE BULLETIN

Effective Serial Numbers:

Ride: FLYING BOBS

Subject: CAR MOUNT INSPECTION

This bulletin deals with the inspection of car hangers, car frames and spreader bars. All owners are to perform the checks listed in this bulletin at the intervals prescribed. Any abnormal conditions must be reported to Chance Manufacturing Company immediately.

CAR HANGERS

Remove the cars and disassemble all car hangers.

FIGURE A

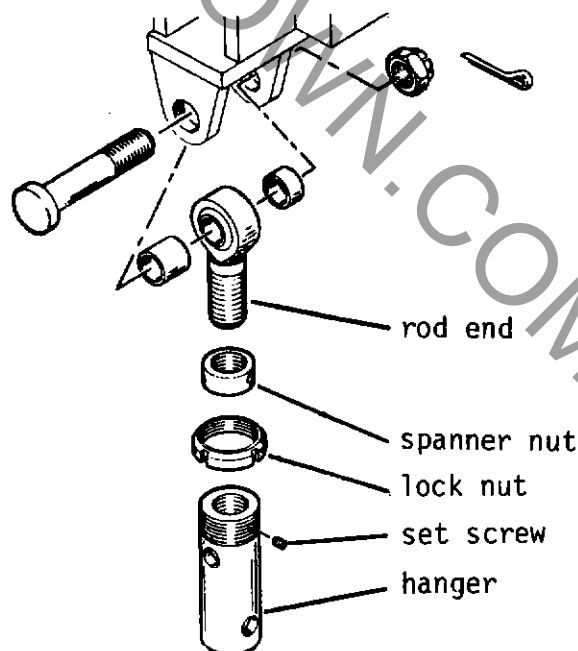

Inspect all parts for signs of wear, bending, cracking, distorted threads (internal and external) or any other physical damage. When checking the car hanger rod ends, look for tack welds with saw cuts. If any saw cuts are found, replace the rod ends.

Thread the rod ends into the car hangers. The rod ends must fit securely. If there is any looseness present, replace both parts.

Factory and Sales Office: 4219 Irving • P.O. Box 12328 • Wichita, Kansas 67277 • (316) 942-7411

Reassemble the car hangers. Tighten the spanner nuts (or jam nuts if so equipped) and set screws in such a manner that the rod ends are held securely in the hangers. When the cars are installed, tighten the lock nuts against the car frames.

This inspection is to be performed monthly. Spanner nuts, jam nuts, set screws and lock nuts should also be checked weekly or whenever the ride is set up, whichever occurs more frequently.

CABLES AND CHAINS

Inspect the cables or chains that go through each car (See FIGURE B & C).

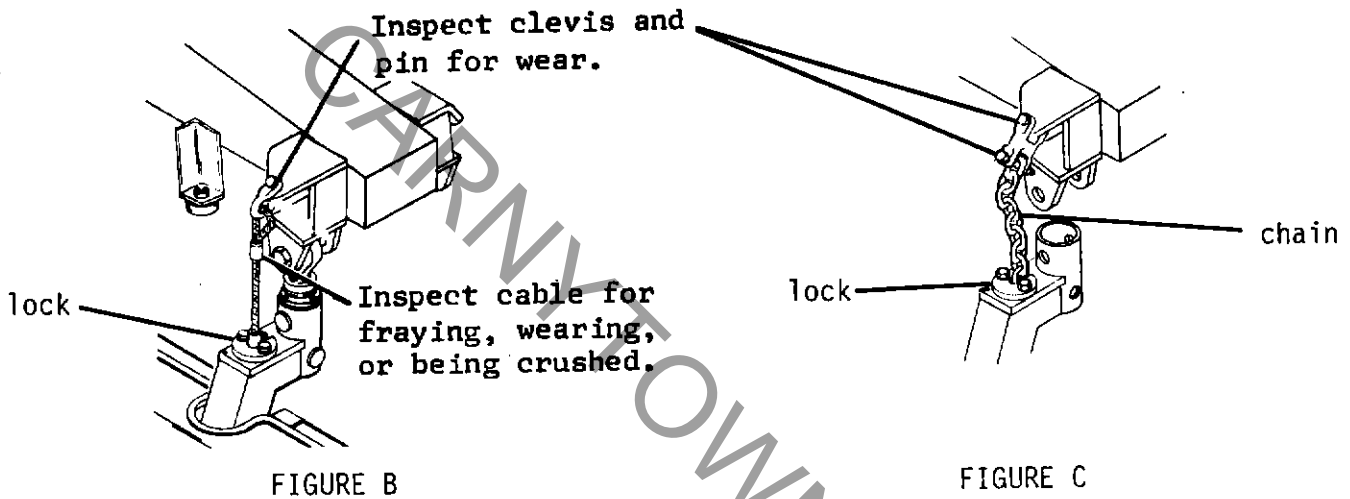

Check the cables for any signs of fraying or crimping. If any cable is damaged, replace it with Chance part number 337-837.

Inspect the chains for signs of wear or stress. If any chain is damaged, replace it with Chance part number 337-603-18, or 3/8" high tensile alloy chain. The chain must be 10' 6-5/8" long and have a working load of 6,600 lbs.

CAUTION: DO NOT USE PROOF COIL HARDWARE STORE CHAIN. DO NOT SPLICE ANY CHAIN.

Locks must be attached to chains or cables to hold them securely in position. Replace any shock band assemblies which are broken or damaged.

Check the condition of chains, cables, and attaching parts (including locks) daily.

CAR FRAMES

Remove the floor inspection covers and inspect the car frames.

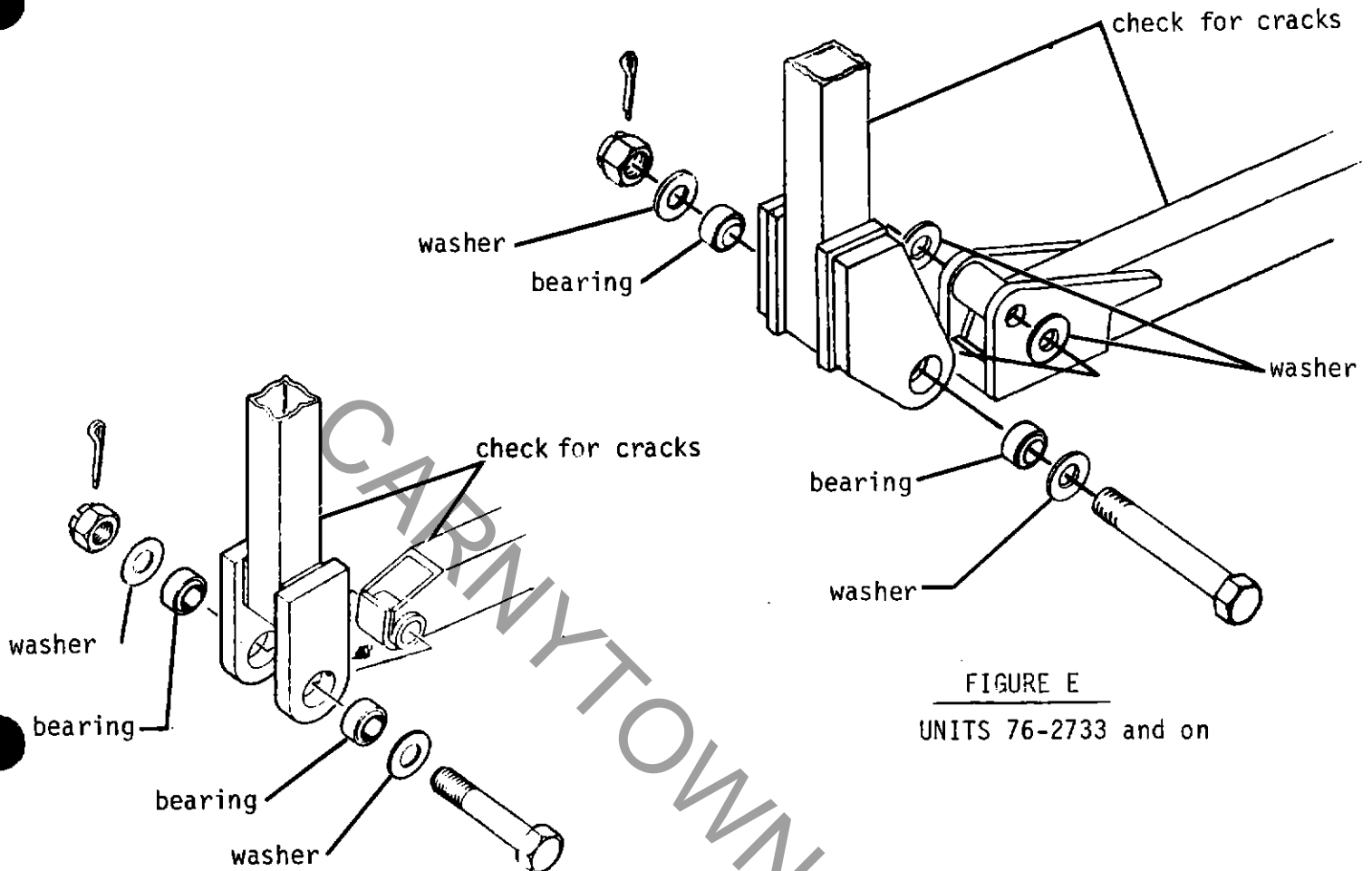

FIGURE D
UNITS 71-2701 through 76-2732

FIGURE E
UNITS 76-2733 and on

Check each frame structure for cracks, bends or "egged" holes. See FIGURE D & E. The bearings must turn easily. They should be lubricated when the frame joints are reassembled. Tighten the bolts to remove any play between the two arms. It may be necessary to replace the bearings and washers to remove all of the play.

Inspect the cables or chains in this area of the cars for fraying or wearing. This inspection should be performed monthly.

SPREADER BARS

Remove the rod ends from the spreader bars one at a time. Inspect the rod ends for tack welds with saw cuts. If any saw cuts are found, replace the rod ends. Check the attachment points for worn bushings and pins. Thread the rod ends into the spreaders to check the fit. If there is any looseness, replace both parts.

Return the spreader bars to their original adjustments and tighten the jam nuts.

NOTE: DO NOT CHANGE THE ADJUSTMENT OF THE SPREADER BARS.

Perform this inspection annually.

All spreader bars should be visually checked at least once a week for cracks or bends. Attachment points should be checked for worn bushings and pins. Rides with unequal length spreader bars should also be inspected for cracks at points marked A. If cracks have developed, do not attempt to weld them, but replace the bar with new ones available from the factory.

Some spreader bars have broken due to slop in the spreader bar connections at points marked B. This is the result of crossrods not being installed or not being properly tightened, creating a shock load. Worn pins and bushings should be replaced with new ones available from the factory.

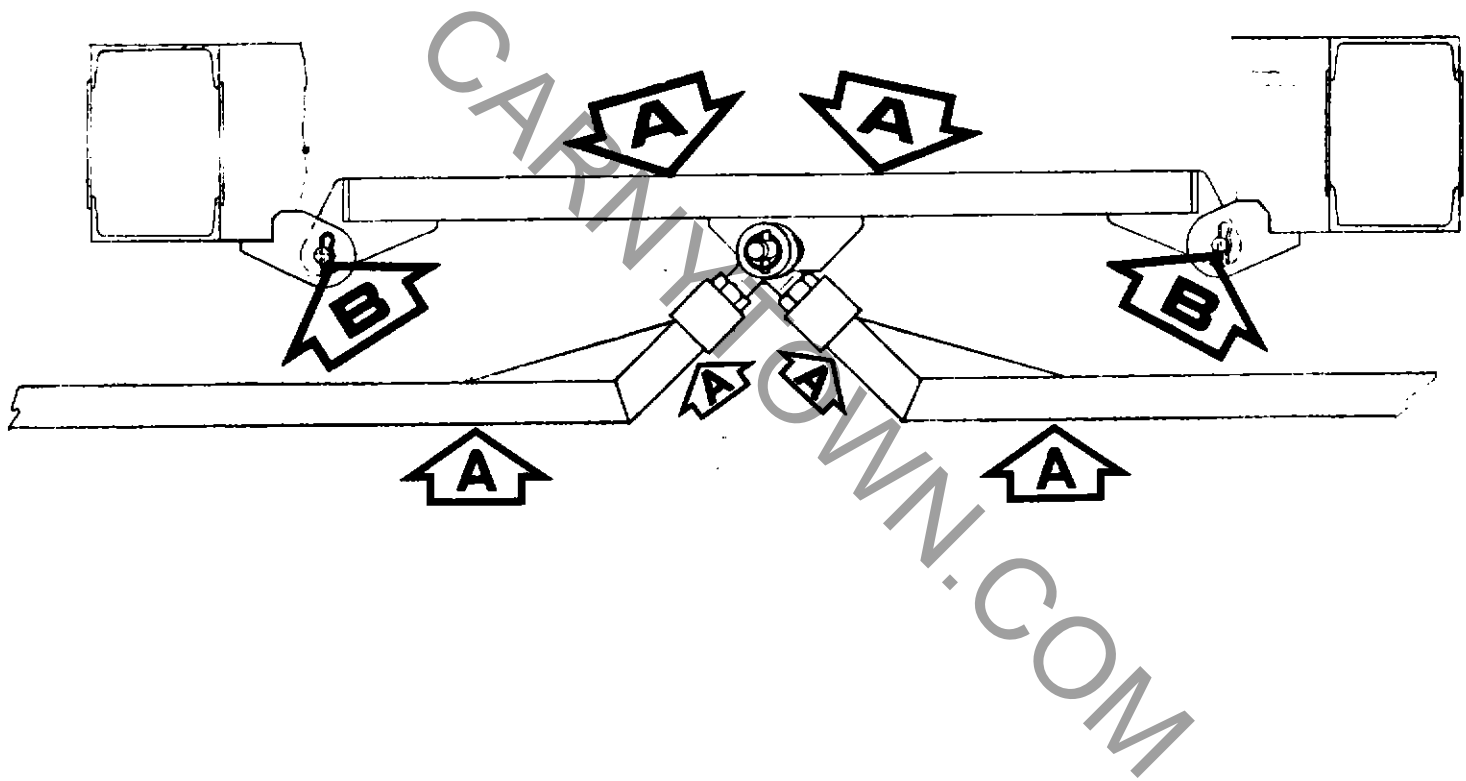



Number: B37-0139-0B

Date: 2-24-84

Supersedes: 139
37-139A

America's Largest Manufacturer of Amusement Rides

SERVICE BULLETIN

Effective Serial Numbers: ALL UNITS

Ride: FLYING BOBS / MUSIC FEST Subject: MAIN HUB BEARING AND
MASTER SWEEP BOLT CHECK

Service Information Bulletin number 37-139A has been superseded by this bulletin. It is no longer in effect and should be destroyed.

This bulletin is concerned with the problem of sheared bolt heads in two critical areas: the MAIN HUB BEARING and the MASTER SWEEP.

All owners are to check the bolts as described in the following procedures and report any abnormal conditions to Chance Manufacturing immediately.

MAIN HUB BEARING

There have been a few cases reported of the center hub bearing bolts working loose. If enough bolts do come loose, the center section will work up and down from the action of the sweeps as they revolve. This, in turn, will cause the plate to shear the bolt heads off.

Inspect all the bolts that go into the center bearing. This includes the bolts that go into the bottom side as well as the ones on top.

If any bolts less than Grade 8 are found, they must be replaced with Grade 8 bolts immediately. (See description under SHEARED BOLTS for correct length.)

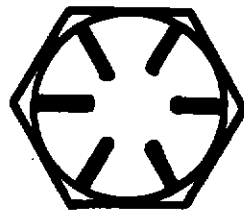

A Grade 8 bolt has six raised marks on the head. A lesser number of marks indicates a lower grade of bolt.

FIGURE 1

All bolts should be checked for tightness once a week.

The top bolts are not very accessible since they are under the sweep hubs. A large box-end wrench, 15/16, seems to work well. When using the box-end, the bolts must be tightened as much as possible since it is hard to obtain any leverage.

The bottom bolts are readily accessible, and a torque wrench or impact wrench can be used. Torque values for both top and bottom bolts are 160ft/lb dry, and 130 ft/lb if lubricated.

After checking all bolts, visually inspect edge of center hub plate to make sure it is drawn down tightly against the bearing.

SHEARED BOLTS

In the event any of the heads of the top bolts have been sheared off, center punch the sheared bolt. Drill the bolt to accept an "Easy Out" and remove the bolt shank.

Install new bolt 5/8-11 x 2 1/4 Grade 8 and hard washer. Torque as specified.

If the heads of any of the lower bolts have been sheared off, center punch the sheared bolt. Drill the bolt to accept an "Easy Out" and remove the bolt shank.

On Rides Serial Numbers 71-2703 through 76-2734, 427247 and 427257, install new 5/8-11 x 4 Grade 8 bolts and hard washers. Torque as specified.

Rides Serial Numbers 77-2736 and on, install 5/8-11 x 2 1/4 Grade 8 bolts and hard washers. Torque as specified.

IMPORTANT: ALL RIDES MUST HAVE GRADE 8 HARDWARE, REGARDLESS OF BOLT LENGTH.

Top bolts are accessible by reaching in between and under sweep hubs

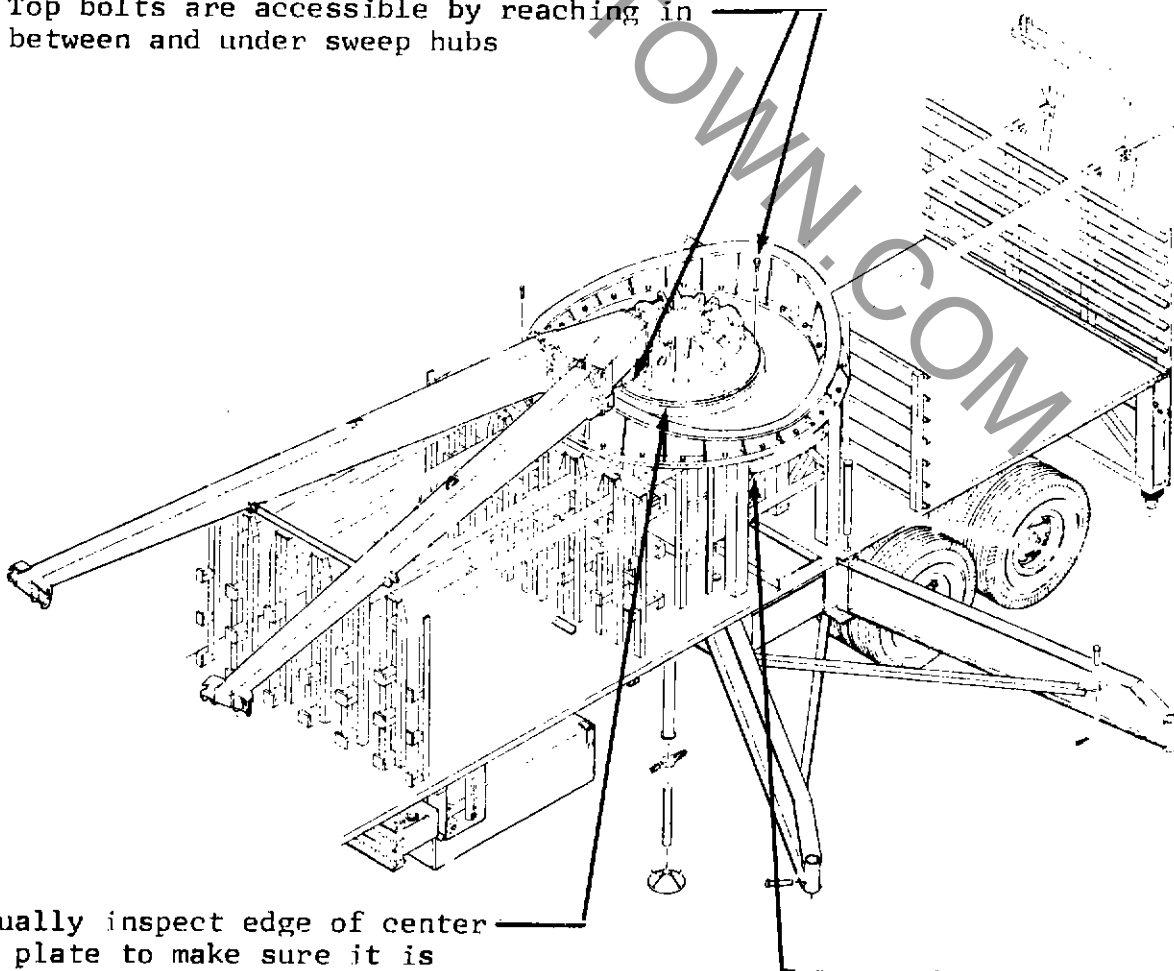

Visually inspect edge of center hub plate to make sure it is being pulled down tightly against top of bearing

Bottom bolts are accessible from bottom side of track

FIGURE 2

MASTER SWEEP HUB BOLTS

If the bolts that attach the master sweep bearing cap to the main hub become loose enough, the hub will start to work back and forth, which will cause the bolts to be sheared in two. Should this happen, the sweep will drop down, tearing into the inner panels.

All owners are to check the bolts as described in the following procedures and report any abnormal conditions to Chance Manufacturing immediately.

1. First, check the bolts to determine if they are Grade 8. This is done by identifying the marking on the bolt head. If any bolts less than Grade 8 are found, they must be replaced with 3/4-10 x 4-1/2 Grade 8 bolts immediately (See FIGURE 1).

2. Check tightness of bolts using torque wrench. Torque values are 280 ft/lbs dry and 230 ft/lbs if lubricated.

If the bolts are found to be loose when they are inspected, perform the following.

3. Using the chain hoist, raise the sweep just enough to take the weight off the hub hinge point.

4. Remove the bolts (A) and inspect the holes in the bearing cap (B) for an egging condition.

5. Check the threaded holes in the base (C) by hand-screwing a bolt into it. The bolt should not have any wobble or play as it is screwed in.

6. Inspect the sweep ear holes (D) immediately on either side of the master sweep for egging.

If any of the conditions discussed in Paragraphs 4, 5 or 6 exist, consult Chance Manufacturing Company for instructions.

DO NOT OPERATE RIDE

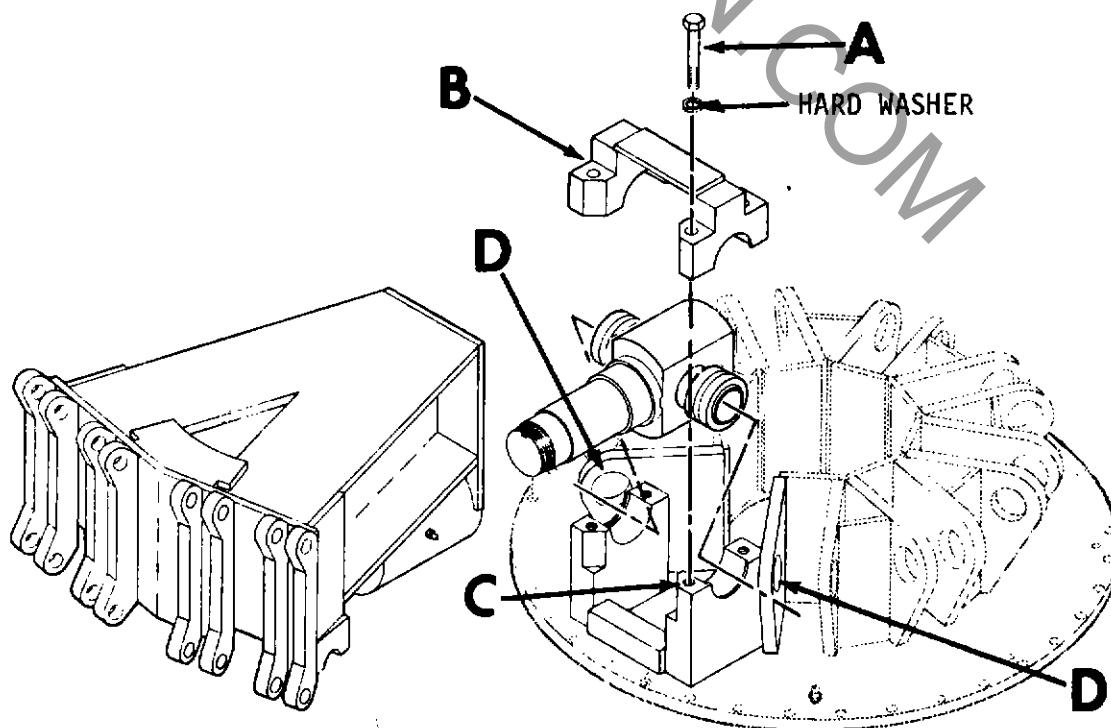

FIGURE 3

If all items in Paragraphs 4, 5 or 6 are in good condition, proceed with the following.

7. After removing bolts (A) clean the bolt threads and the hole threads with a non-oil base solvent to make sure there is no oil or grease present.

8. Apply "Green" Loctite to bolt and hole and tighten to specified torque as stated in Step 2.

9. After corrections have been made, test run the ride and observe the master sweep hub to make sure it is not working back and forth. If it is working, consult the factory.

CHECK THE BOLTS (A) ONCE A WEEK FOR SPECIFIED TORQUE

CARNYTOWN.COM



Number: 59

Date: 7/25/73

Supersedes:

America's Largest Manufacturer of Amusement Rides

SERVICE BULLETIN

Effective Serial Numbers:

Ride: FLYING BOBS
VARIABLE SPEED ONLY

Subject: DECAL INSTALLATION

Enclosed with this sheet is a self-stick decal. Attach decal to control panel in the control house. Position decal by the steering wheel so that it is easy to read.

Clean surface with a non-oil base solvent such as alcohol or paint thinner so decal will stick better.

POSITION DECAL SO IT IS
EASY TO READ

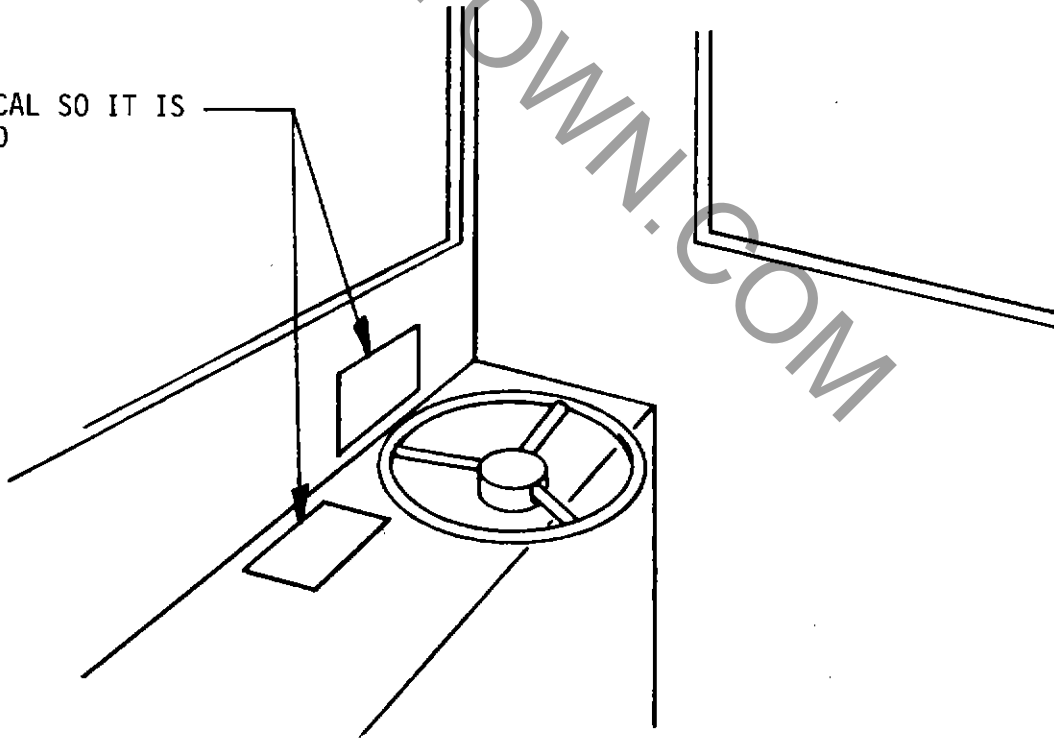

CARNYTOWN.COM



ALLAN HERSCHELL

CHANCE
MANUFACTURING CO., INC.

Number: 23

Date: 12-6-72

Superceeds:

Number:

Date: April 1969

Service Information

Ride:

FLYING BOBS

Subject:

ERECTION

PORTABLE

REFERENCE:

Prints -

337-147 Drive Assembly	337-308 General Arrangement
337-348 Car Hanger Bearing	337-179 Center Column Assembly
337-231 Car Assembly	337-290 Stub Column Assy.
337-359 Control Room Wiring	337-259 Speaker Mounting
337-245 Center Column Wiring	337-146 Drive "A" Frame
337-243 Cornice Wiring	337-261 Sign Support Arrangement

1. Using the transit provided with the ride, check the level of the ground to determine the amount of blocking to be placed under #1 trailer wheels.
2. Refer to General Arrangement drawing 337-308. Set two stakes in ground back from the midway 23 ft. 3 inches and left of area where ride is to be placed. Now, pace off 43 ft. down the midway and place the second stake 29 ft. 9 inches back, as shown on General Arrangement drawing 337-308. Spot trailer #1 with driver side facing the midway and centered over the two stakes. Now, either pull the trailer up on the blocking under the tires or jack the trailer up to place the blocking.
3. Level #1 trailer using 24 inch level on side level angles and front and rear level points. Use suitable wood blocking under tires and landing gear to adequately distribute the load. NOTE: On very soft ground, four 3 inch x 10 inch x 7 ft. planks should be used under the tires. Gear may be used separately by removing the connecting bolt at center of trailer. The trailer should be leveled approximately 49 inches above the ground.
4. Remove the five 25 ft. main upper trusses from the racks on either side of trailer.
5. Remove columns and outer panels and place around the ride, numbering counter-clockwise from control house.
6. Leaving mast in down position, raise gin pole straight up and pin brace in place.

Factory and General Office, 4219 Irving, Box 2397 Wichita, Kansas 67201

Area Code (316) 942-7411

Sales Office:

103 Ross Ave., Dallas, Texas 75202

Area Code (214) 742-3802

7. Tie off all track except #6 to center column.
8. Attach block and tackle to #6 track from gin pole.
9. Remove bracing from #6 track and lower top of track down with block and tackle.
10. Set #6 track on ground about 8 ft. back of the trailer.
11. Using same procedure, remove next track and place in position on ride, fastening to #1 track. NOTE: Tracks are numbered clockwise. #1 track is permanently welded to front of trailer.
12. All other track is to be removed and placed in position on the ride.
13. Place #6 track in place and pin to trailer.
14. Attach block and tackle from gin pole to rear of trailer and pull tent pole up in place and pin.
15. Remove outrigger stabilizer and attach to both sides of the trailer.
16. Install all square bracing from center to track.
17. Use transit and level all track using good blocking at each upright of track. CAUTION: Track blocking must be large enough to equally distribute load of the ride.
18. Remove all platform supports and place in pockets on outside of track. NOTE: 13/16" \emptyset must be at track end as this hole is for the inside scenery.
19. Raise corresponding column and place other end of platform support. (Place cable and hoist on #4 and #6 columns before raising column.) REFERENCE: Drawing 337-261.
20. Use transit again to level columns and properly block. Use lower angle support for leveling.
21. Place outside panels between columns.
22. Remove cornice panels from under control house and place in position at top of columns. Lock lower pin of cornice to column with 3/16" hairpins.
23. Do not place stub column or cornice #4 - #5 and #5 - #6 at this time.
24. Raise the main trusses and fasten between column and center pole. Locate on columns #3, #7, #11, #15 and #19. REFERENCE: General Arrangement drawing 337-308.
25. Raise the 5 intermediate trusses and place between main trusses - truss to truss.
26. Raise the 5 upper inner panel supports and place in position on top of intermediate trusses and pin to center with hairpins.

27. Remove all of the platform and install on ride with the exception of #4 - #5 and #5 - #6. These must be left out in order to unload cars and sweeps.
28. #2 trailer should now be brought up parallel to columns #4 and #6 with sign spotted in line with vertical track.
29. Attach, raising hooks to eyes at top of sign frame and take strain on hoist.
30. Remove pins support from sign and raise sign enough to clear sign lower support. REFERENCE: Stub Column Assembly 337-290.
31. Carefully raise sign into position and position the support on column to underside of sign frame.
32. #2 trailer should now be moved out and respotted with rear end in exact center between columns #4 and #6 and facing the center of the ride. A string or wire stretched alongside the trailer can help guide the trailer into place.
33. Remove gantry track extension from sides of trailer and assemble to rear of trailer. REFERENCE: Drawing 337-430.
34. Attach side bracing and sand shoes to extension.
35. Assemble gantry on top of trailer.
36. Remove the first two plain sweeps from the trailer and assemble next to the stabilizer sweep. Number on the sweep end should match the number stamped on sweep rotating head.
37. Remove sweep spacers from #1 trailer possum and pin to sweeps as the sweeps are assembled to ride.
38. **CAUTION:** Use rope blocks to hold back sweep and block under wheels to prevent sweeps from getting out of hand and rolling down hill.
39. Remove drive sweep and matching motors according to color code on sweep and motor.
40. Proceed as above to place the remaining sweeps on the ride.
41. Assemble drive bracing and belts. REFERENCE: Drive Assembly drawing 337-147.
42. Remove upper inside panels from possum and assemble to trusses and pin in place.
43. Remove lower panel supports from racking and tie in lower portion of upper panels to center pole.
44. Hook light cams to pins at top of inner panels and pin lower end to panels using hairpins.
45. Remove lower inside panels and assemble to platform supports. Pin to track with brackets.

46. Remove cars from racks and assemble to ends of sweeps. REFERENCE: Drawing 337-348 for space and bolt arrangement.
47. Connect magnet wires.
48. Remove #2 Trailer from ride.
49. Assemble stub column support. REFERENCE: Drawing 337-290.
50. Place lower stub column and platform at #5.
51. Assemble tent above in trusses.
52. Place icicles in place under cornice.
53. Add double flood light assembly #3, #7, #11, #15 and #19. (May be mounted earlier if electricity is available and lighting is desired for erection).
54. Place speaker mounting in place on columns #1 and #10. REFERENCE: Drawing 337-259.
55. String motor wires out the sweeps and make all the necessary wiring connections at center.
56. String extension cords from lower center to lower columns for floods, sign and cornice. REFERENCE: Drawing 337-476.
57. Make all the necessary wire connections for cornice and flood light of control house.
58. String speaker wires under the ride.
59. Record player to be placed under the ride to avoid vibration.
60. String garlands from columns to center panels around the ride except on columns #10 and #11, and #1 and #20 at hills.
61. Run power supply 120/208 3 phase, 4 wire, to terminals under lower left side of #1 trailer. REFERENCE: Drawing 337-359 and specifications sheet for power requirements. Required 50 KVA @ 120/208, 3 phase, 4 wire or 25 KVA @220 or 230 volt, 3 phase, plus 25 KVA @ 120 volt 1 phase.



Number: B37-0143-0B

Date: 2-24-84

Supersedes: 37-143
37-143A

America's Largest Manufacturer of Amusement Rides

SERVICE BULLETIN

Effective Serial Numbers: 71-2701 thru 76-2735

Ride: FLYING BOBS

Subject: MAIN HUB BEARING INSTALLATION

Service information bulletin number 37-143A has been superseded by this bulletin. It is no longer in effect and should be destroyed.

This kit is to be used only when installing a new 290-04939 Main Hub Bearing in Flying Bobs serial numbers 71-2701 thru 76-2735.

Before installing this kit, read the instructions completely and familiarize yourself with the parts listed below. Make certain all parts have been received. If any parts are missing, notify Chance Manufacturing Co. immediately. Do not substitute an inferior grade of material or part.

All work must be done by competent qualified mechanics capable of understanding the function of the parts and their proper installation.

See Drawing Kit #37-143A for complete information.

If you have any questions concerning the installation of this kit, please notify Chance Manufacturing for assistance.

PARTS INCLUDED IN KIT

<u>QUANTITY</u>	<u>PART NUMBER</u>	<u>DESCRIPTION</u>
69	5/8"	Hard Washer
1	290-04939	Bearing
36	5/8-11 x 1 3/4"	Hex Head Cap Screw - Grade 8
30	5/8-11 x 2"	Hex Head Cap Screw - Grade 8
3	5/8-11 x 3"	Socket Head Cap Screw
3	5/8-11 x 3"	Hex Head Cap Screw - Grade 8
3	5/8"	High-Collar Helical Spring Washer
		Red Loctite - Grade A
	bottles	

Factory and Sales Office: 4219 Irving • P.O. Box 12328 • Wichita, Kansas 67277 • (316) 942-7411

When installing the hub to the upper portion of the bearing, use (36) 5/8-11 x 1 3/4" Grade 8 cap screws.

When installing the lower portion of the bearing, use (30) 5/8-11 x 2" Grade 8 hex head cap screws, (3) 5/8-11 x 3" Grade 8 hex head cap screws, and (3) 5/8-11 x 3" socket head cap screws.

Use hard washers with all hex head cap screws and high collar helical spring washers with all socket head cap screws. Treat threads with locktite and torque to 160 ft/lb. dry and 130 ft/lb. if lubricated.

The length of cap screws required may vary among rides. All cap screws must thread into the bearing a minimum of 5/8". Should your ride require a different length of cap screw than those provided in the kit, notify the factory immediately for exchange.

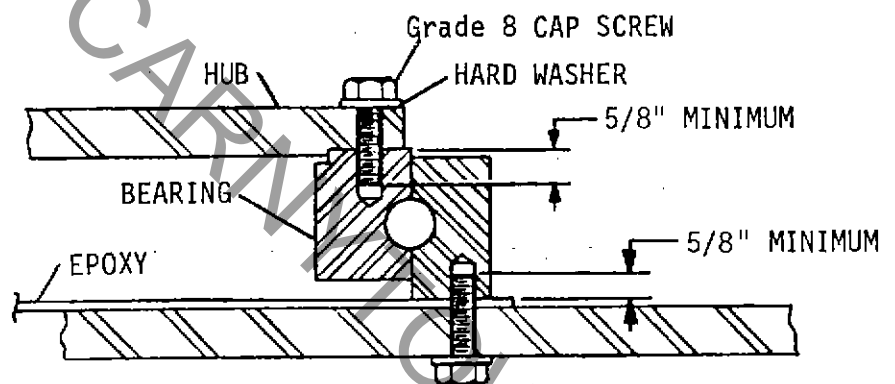

The attached CERTIFICATION OF COMPLIANCE must be completed and returned to Chance Manufacturing, Inc., within seven (7) days of receipt of kit.

CARNYTOWN.COM

CARNYTOWN.COM



Number: B37-0143-0B

Date: 2-24-84

Supersedes: 37-143
37-143A

America's Largest Manufacturer of Amusement Rides

SERVICE BULLETIN

Effective Serial Numbers: 71-2701 thru 76-2735

Ride: FLYING BOBS

Subject: MAIN HUB BEARING INSTALLATION

Service information bulletin number 37-143A has been superseded by this bulletin. It is no longer in effect and should be destroyed.

This kit is to be used only when installing a new 290-04939 Main Hub Bearing in Flying Bobs serial numbers 71-2701 thru 76-2735.

Before installing this kit, read the instructions completely and familiarize yourself with the parts listed below. Make certain all parts have been received. If any parts are missing, notify Chance Manufacturing Co. immediately. Do not substitute an inferior grade of material or part.

All work must be done by competent qualified mechanics capable of understanding the function of the parts and their proper installation.

See Drawing Kit #37-143A for complete information.

If you have any questions concerning the installation of this kit, please notify Chance Manufacturing for assistance.

PARTS INCLUDED IN KIT

<u>QUANTITY</u>	<u>PART NUMBER</u>	<u>DESCRIPTION</u>
69	5/8"	Hard Washer
1	290-04939	Bearing
36	5/8-11 x 1 3/4"	Hex Head Cap Screw - Grade 8
30	5/8-11 x 2"	Hex Head Cap Screw - Grade 8
3	5/8-11 x 3"	Socket Head Cap Screw
3	5/8-11 x 3"	Hex Head Cap Screw - Grade 8
3	5/8"	High-Collar Helical Spring Washer
		Red Loctite - Grade A

bottles

Factory and Sales Office: 4219 Irving • P.O. Box 12328 • Wichita, Kansas 67277 • (316) 942-7411

When installing the hub to the upper portion of the bearing, use (36) 5/8-11 x 1 3/4" Grade 8 cap screws.

When installing the lower portion of the bearing, use (30) 5/8-11 x 2" Grade 8 hex head cap screws, (3) 5/8-11 x 3" Grade 8 hex head cap screws, and (3) 5/8-11 x 3" socket head cap screws.

Use hard washers with all hex head cap screws and high collar helical spring washers with all socket head cap screws. Treat threads with locktite and torque to 160 ft/lb. dry and 130 ft/lb. if lubricated.

The length of cap screws required may vary among rides. All cap screws must thread into the bearing a minimum of 5/8". Should your ride require a different length of cap screw than those provided in the kit, notify the factory immediately for exchange.

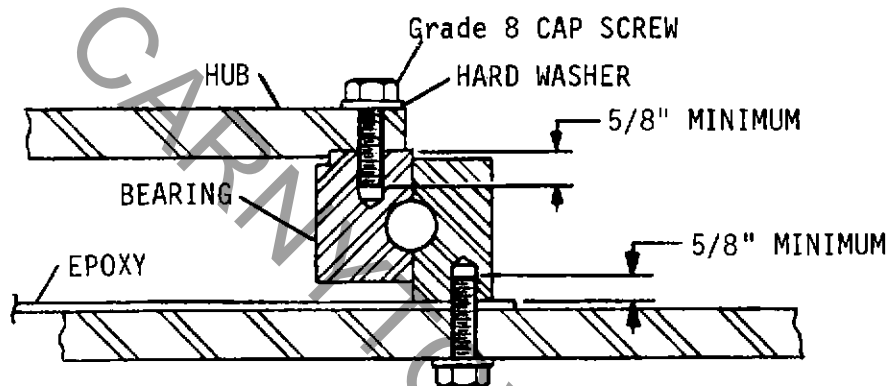

The attached CERTIFICATION OF COMPLIANCE must be completed and returned to Chance Manufacturing, Inc., within seven (7) days of receipt of kit.