

SPECIFICATION

All specifications in accordance with ASTM standards where applicable

MFG: CHANCE RIDES, INC.
NAME: HELICOPTERS
TYPE: KIDDIE

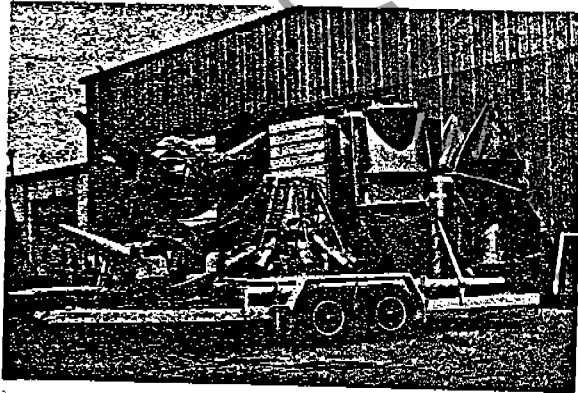
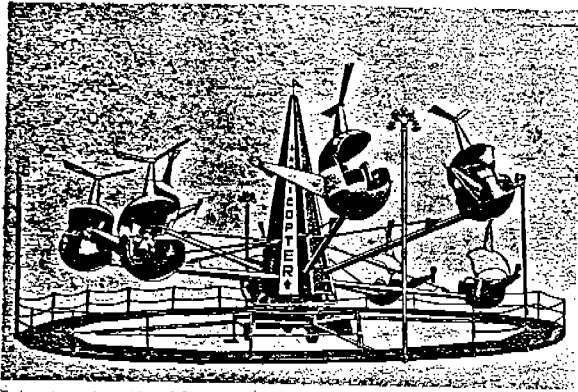

SEATING

Number of cars 8
Maximum number of passengers
per car 2 adults or 3 children
Maximum passenger weight per car 340 lb.
Maximum total number of
passengers 16 adults or 24 children
Maximum total passenger weight 2,720 lb.
Loading All cars simultaneously

PERFORMANCE

Direction of travel Counter-clockwise
Ride speed (maximum) 7 rpm
Ride duration (maximum) 2½ min.
Ride duration (recommended) 2 min.

DRIVE Electro-hydraulic

POWER REQUIREMENTS

Total 15 kW
Motor 10 kW
Lights 5 kW
Minimum/Maximum line voltage 208/230

MOTOR

Type 208 Y/460 volt, 3 phase, 60 Hz
Horsepower rating 10

LIGHTING 110 volt incandescent

STANDARD LEAD-IN CABLE

Size 6/4 type SO
Length 50 ft.

TRAILERING (optional)

Length 324½ in.
Width 8 ft.
Weight (approximate) 11,280 lb.
Brakes Electric
Axles Tandem
Hitch ball diameter 2-5/16 in.

OPTIONS

- Full trailer mounted ride available with or without platform, fence and lighting.
- Center drive mechanism only, with sweeps
- Helicopter vehicles standard (set of 8)
- Star Jet vehicles optional (set of 8)
- Red Baron vehicles optional - manufactured by Bradley & Kaye (set of 8)
- Platforms, fence and outside lighting
- Center lighting

Because we try to improve every Chance product, these specifications are subject to change without notice.

The most complete line of amusement rides for all ages.



4219 Irving
P.O. Box 12328
Wichita, KS 67277-2328

Telephone (316) 942-7411

HELICOPTER

GROUND AREA REQUIRED FOR HELICOPTER (No Clearance Allowances)

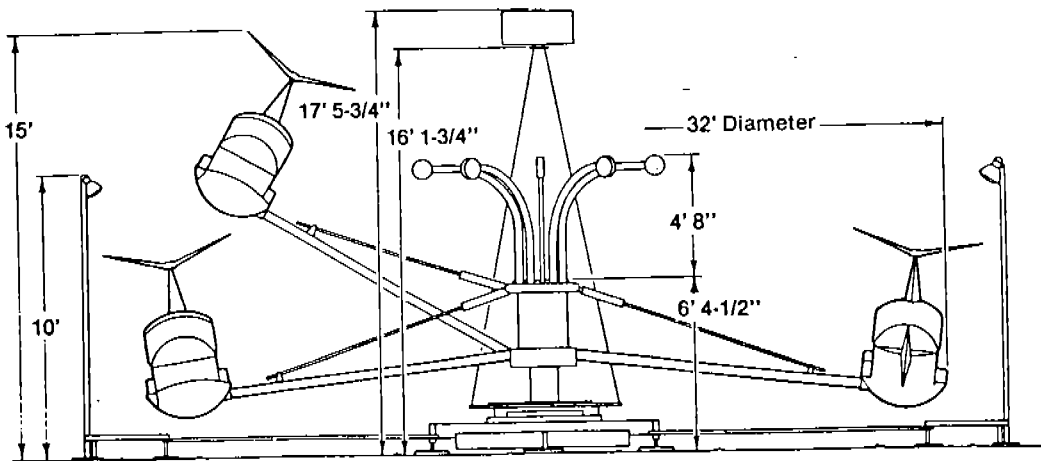
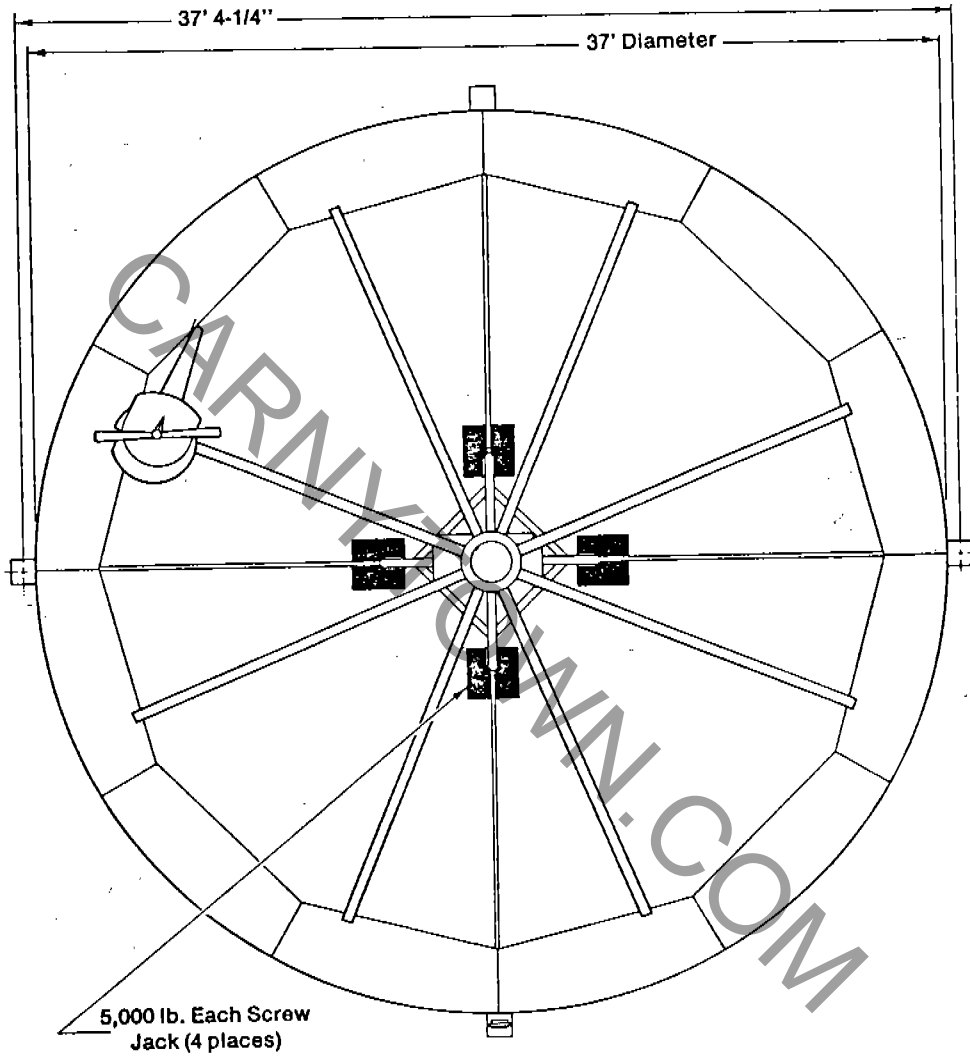

CARNYTOWN.COM

HELICOPTER

Ride Serial Number _____ Owner _____ Date _____

FIELD INSPECTION POINTS

1. () Inspect blocking and leveling.
2. () Inspect jack screws and lock nuts.
3. () Inspect cable leads, electrical connections and grounding per local code.
4. () Inspect pinion and gear for proper mesh with ring gear.
5. () Inspect drive belts for proper tension or deflection (Deflection = belt span in inches / 64).
6. () Inspect all brushes for tension and wear.
7. () Inspect top bearing for sheared or loose mounting bolts.
8. () Check all electrical connections to the commutator.
9. () Inspect sweep bearings for signs of wear.
10. () Inspect all sweeps for any signs of fatigue or cracking. Check wall thickness and replace 1/8" wall with 3/16" wall.
11. () Inspect all sweep pins and hairpins for wear.
12. () Inspect hydraulic cylinder to be sure both end caps are fully screwed in and locked in place with lockwasher on lower end (rod end) and locknut on upper end (clevis end).
13. () Inspect clevis end of hydraulic cylinder. Locknut must be in place and locked against clevis.
14. () Inspect seat belts and hand control lever.
15. () Check ride speed: Maximum 7 rpm.
16. () Check ride for excessive vibration.
17. () Inspect structure for cracks, bad welds, etc. (Bulletin 194).
18. () Inspect the electrical circuit for shorts, bad wires, etc.
19. () Inspect for hydraulic leaks (Bulletin 16).
20. () Inspect overall appearance of ride for cleanliness and general overall upkeep.

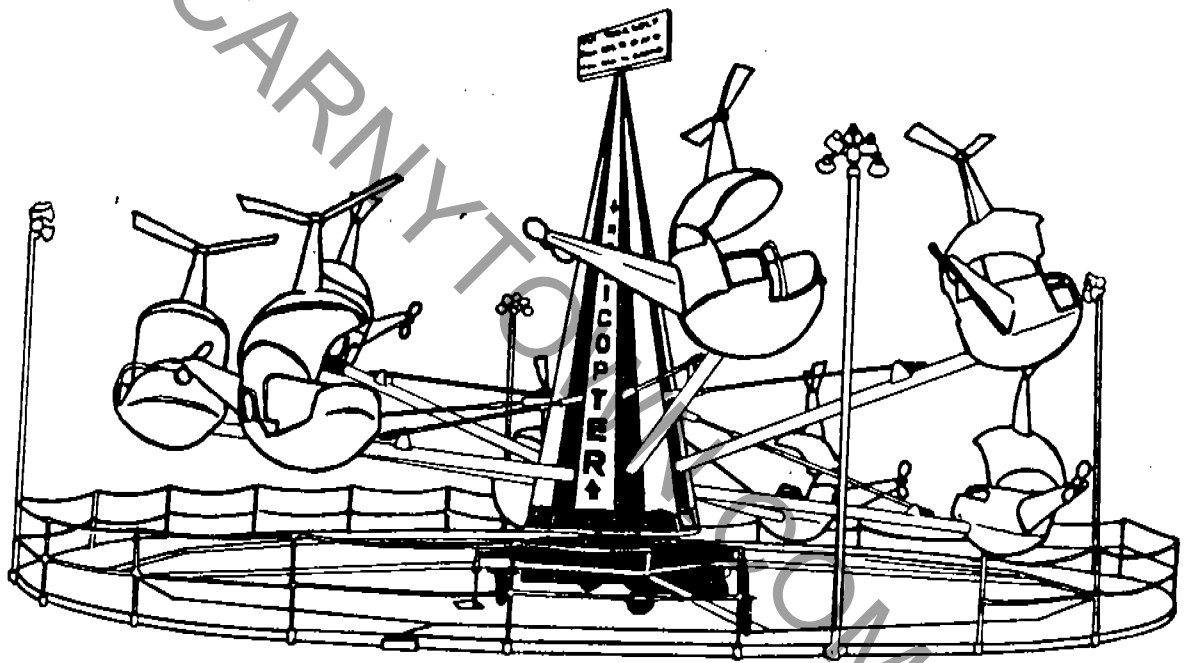

15. () Check ride speed: Maximum 7 rpm.

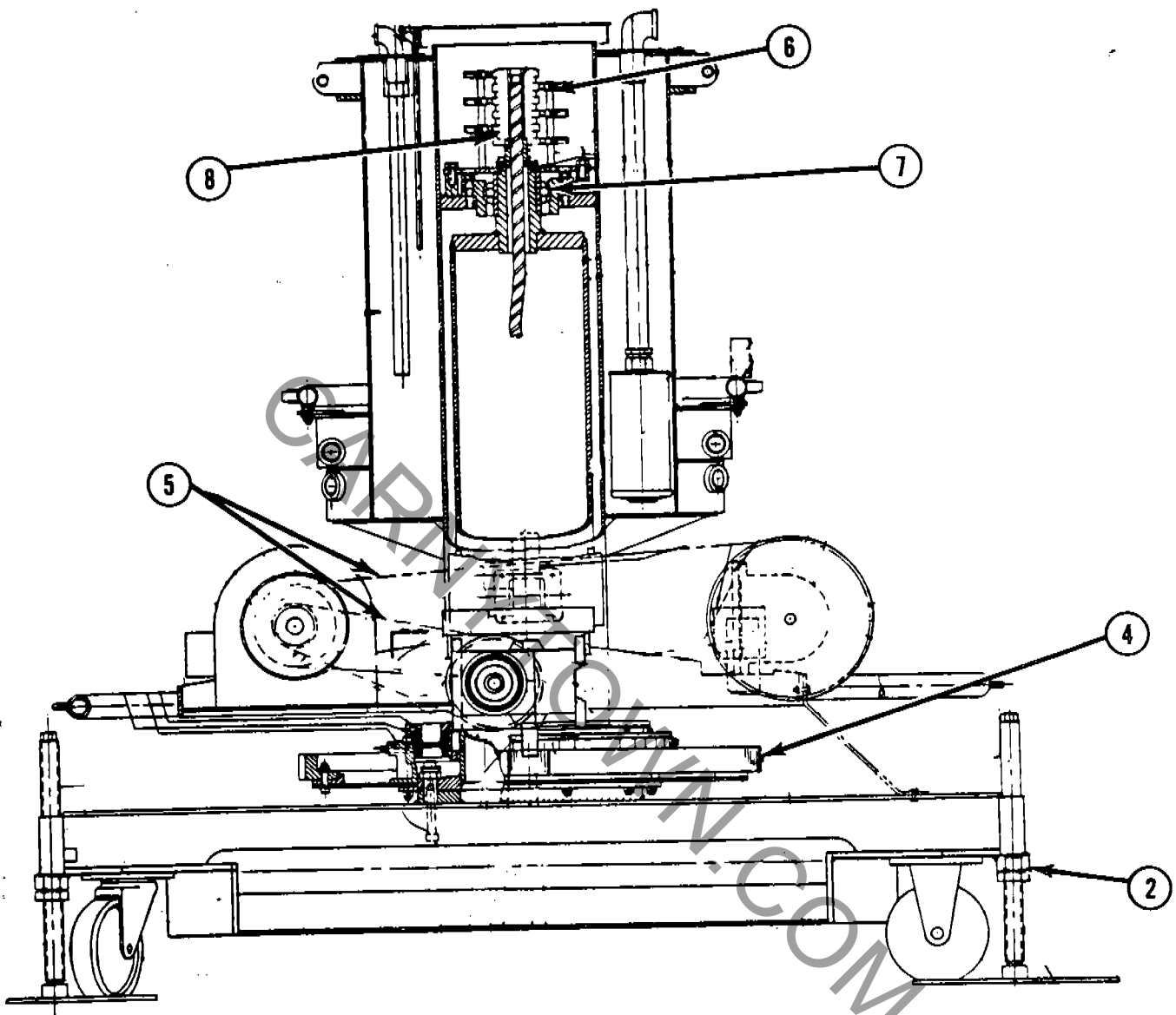

4. () Inspect pinion and gear for proper mesh with ring gear.
5. () Inspect drive belts for proper tension or deflection (Deflection = belt span in inches / 64).
6. () Inspect all brushes for tension and wear.
7. () Inspect top bearing for sheared or loose mounting bolts.
8. () Check all electrical connections to the commutator.

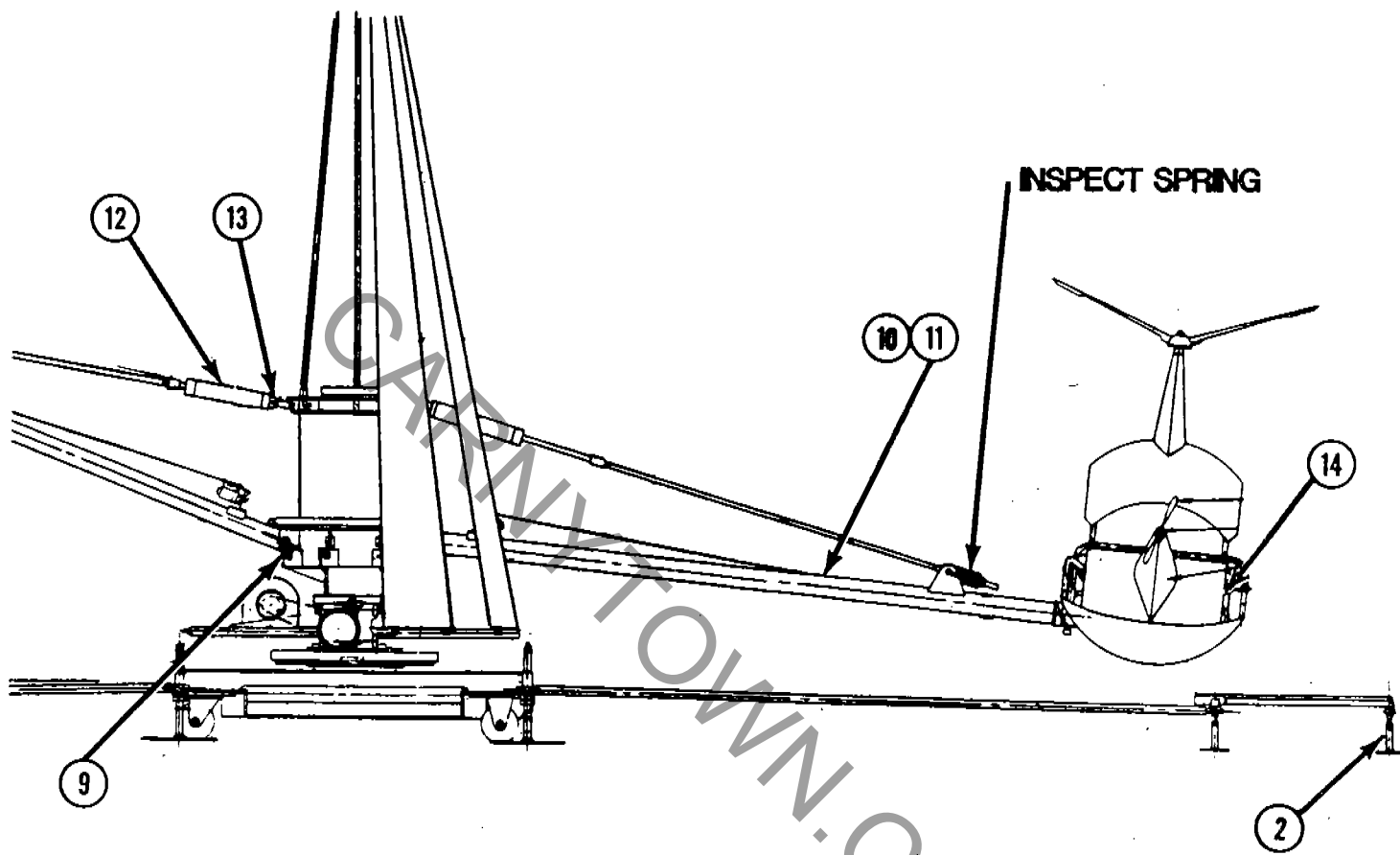

- 2. () Inspect jack screws and lock nuts.
- 9. () Inspect sweep bearings for signs of wear.
- 10. () Inspect all sweeps for any signs of fatigue or cracking. Check wall thickness and replace 1/8" wall with 3/16" wall.
- 11. () Inspect all sweep pins and hairpins for wear.
- 12. () Inspect hydraulic cylinder to be sure both end caps are fully screwed in and locked in place with lockwasher on lower end (rod end) and locknut on upper end (clevis end).
- 13. () Inspect clevis end of hydraulic cylinder. Locknut must be in place and locked against clevis.
- 14. () Inspect seat belts and hand control lever.

NOTE:....The threads on the end caps and barrel can be damaged during disassembly and assembly. If the threads on either part become damaged, discard the part.

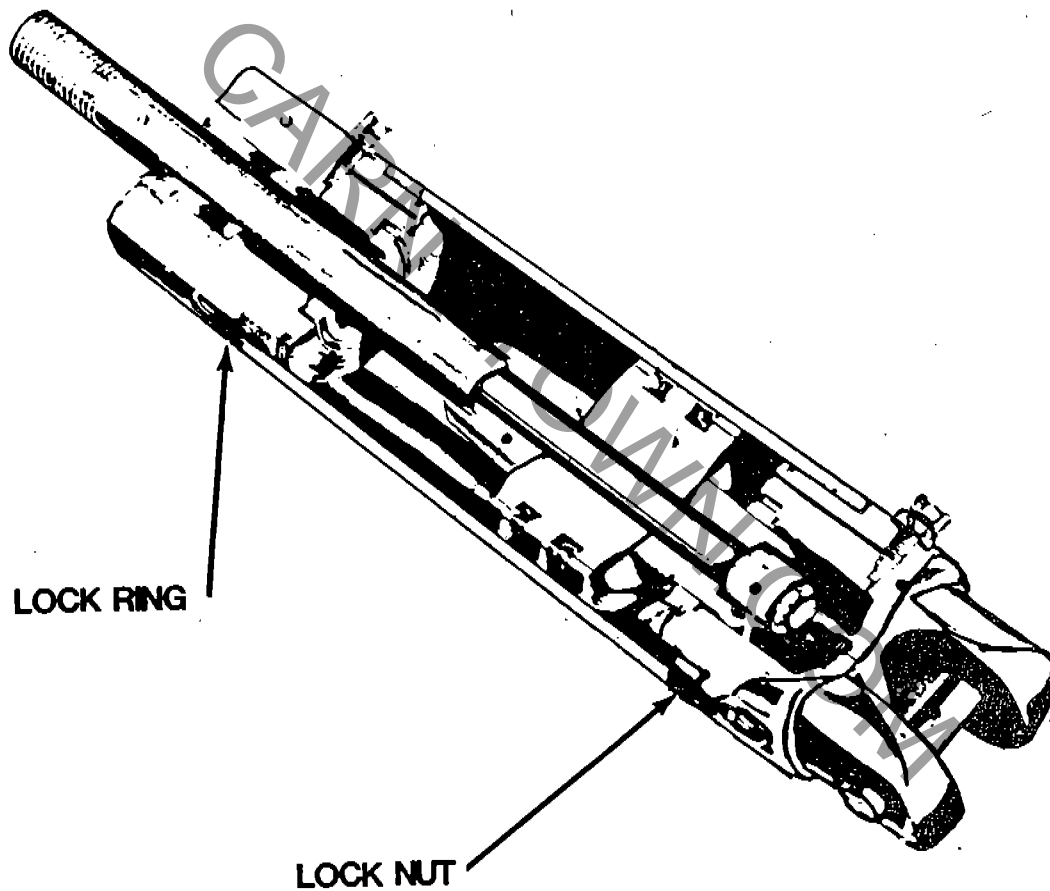

12. () Inspect hydraulic cylinder to be sure both end caps are fully screwed in and locked in place with lockwasher on lower end (rod end) and locknut on upper end (clevis end).



Number: 16

Date: 7-14-72

Supersedes: 2

America's Largest Manufacturer of Amusement Rides

SERVICE BULLETIN

Effective Serial Numbers:

Ride: Helicopter

Subject: Winter Storage

It has been brought to our attention that in storing the Helicopter, rust is forming on vital parts. These are the lift rods and control valve plungers of which there are eight of each on a ride.

Clean thoroughly the polished area of the lift rod as shown by the arrows marked "A" on sketch and the polished plunger shown by arrow "B".

After these points are clean, coat them completely using a protective product which will not run off or permit moisture to get under it such as Mobil Kote 302. This product is obtainable from any Mobil Dealer or distributor or can be ordered from Chance Manufacturing Company.

PROTECTION OF THESE PARTS WILL HELP TO INCREASE THE LIFE OF THE SEALS AND PREVENT LEAKS IN THE HYDRAULIC SYSTEM.

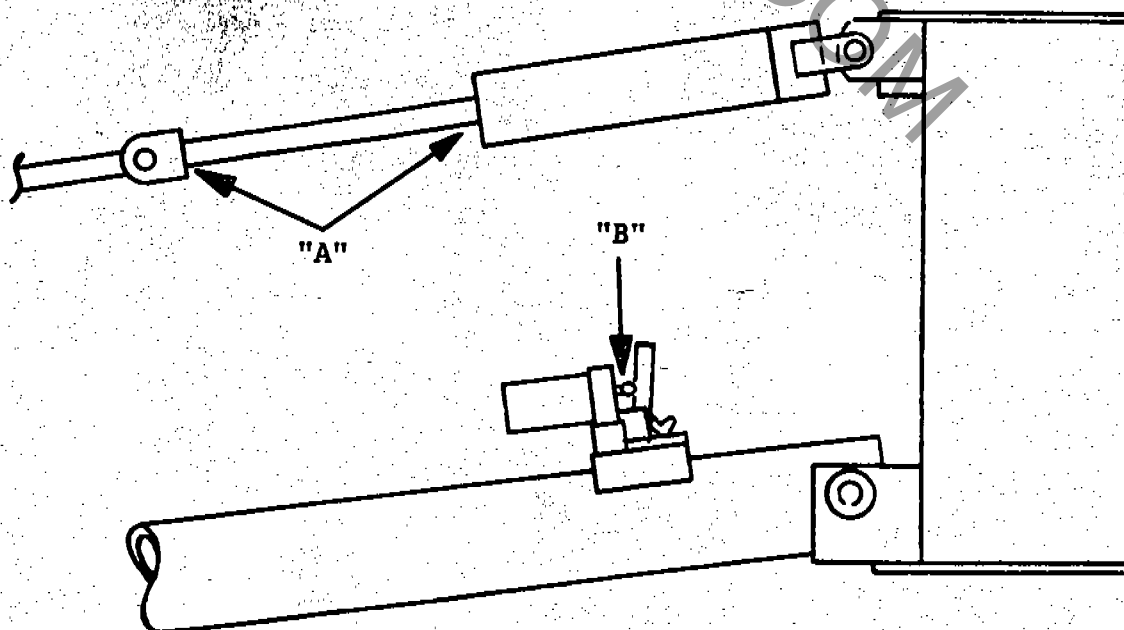

Factory and Sales Office: 4219 Irving • P.O. Box 12328 • Wichita, Kansas 67277 • (316) 942-7411

CARNYTOWN.COM



Number: B17-0194-00

Date: 9-17-79

Supersedes:

America's Largest Manufacturer of Amusement Rides

SERVICE BULLETIN

Effective Serial Numbers: ALL RIDES

Ride: HELICOPTER

Subject: ORIFICE KIT

If you no longer own this ride, please notify Chance Manufacturing Co. of new owners name and address and serial number of ride.

Chance Manufacturing Co. is recommending that all Helicopter ride center bases be inspected for structural cracks as shown in Figure A below. Specifically, the weld area where the center bearing base is welded to the I-beam base should be visually inspected. Bouncing the ride vehicle on the sweep during a visual inspection should open any cracks so they can be seen with the naked eye.

If any cracks are found, Chance Manufacturing Co. should be contacted and the ride should not operate until proper repairs are made.

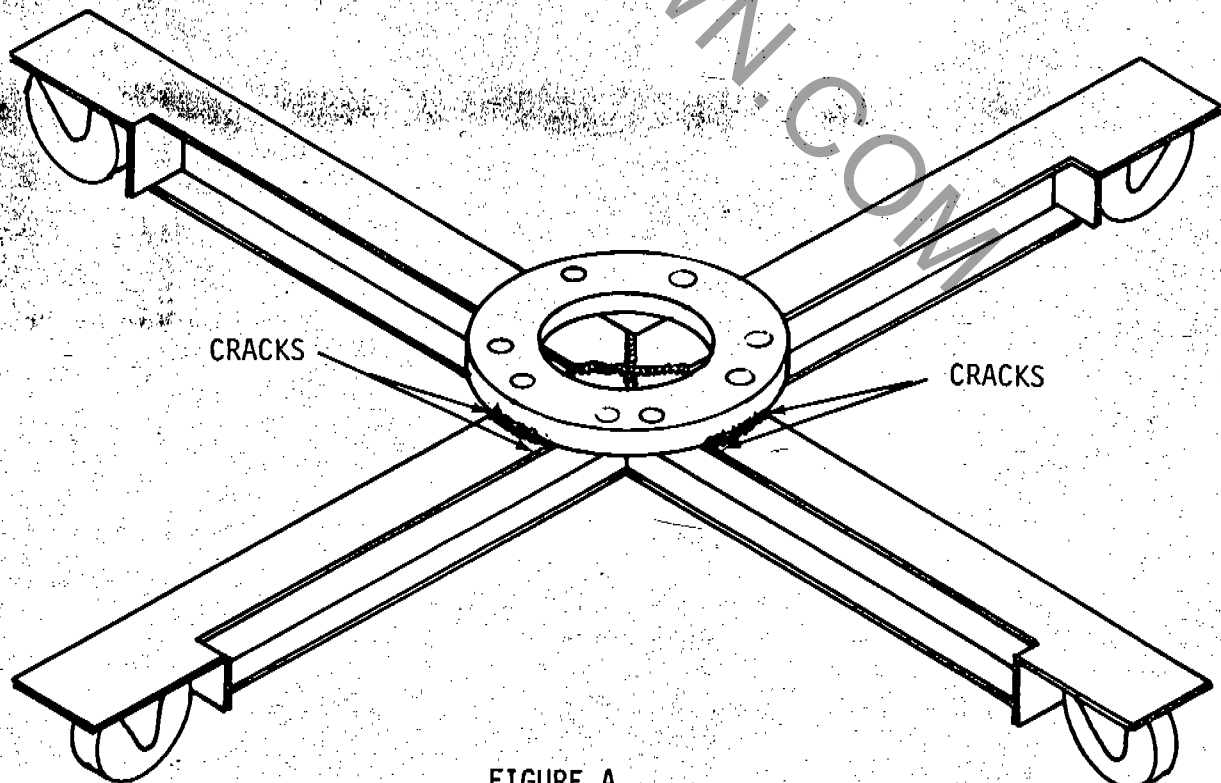

FIGURE A

Factory and Sales Office: 4219 Irving • P.O. Box 12328 • Wichita, Kansas 67277 • (316) 942-7411

Before installing this kit, read the instructions completely and familiarize yourself with the parts listed. Make certain all parts have been received. If any parts are missing, notify Chance Manufacturing Co. immediately. Do not substitute an inferior grade of material or part.

If you have any questions concerning this installation bulletin, please contact Chance Manufacturing for assistance.

ADDITION OF ORIFICE KIT

In order to reduce shock loads to the ride structure, Chance Manufacturing Co. recommends that each Helicopter ride be equipped with a sweep valve orifice, (Kit No. K17-0194-01) as shown in Figure B. This kit will dampen the shock load caused by passengers jerking the lap bar back and forth in rapid succession and will provide a smoother ride to your customers. The kit is easily installed in the field and is available at our bare manufacturing cost for a period of 90 days.

Order from our parts department as follows:

KIT NUMBER K17-0194-01 CONSISTING OF:

QTY.	DESCRIPTION	PART NUMBER
1	BULLETIN NUMBER B17-0194-00	
1	CERTIFICATION OF COMPLIANCE	
8	1/4" CLOSE NIPPLE	688-27658
8	SWEEP VALVE ORIFICE	317-48711

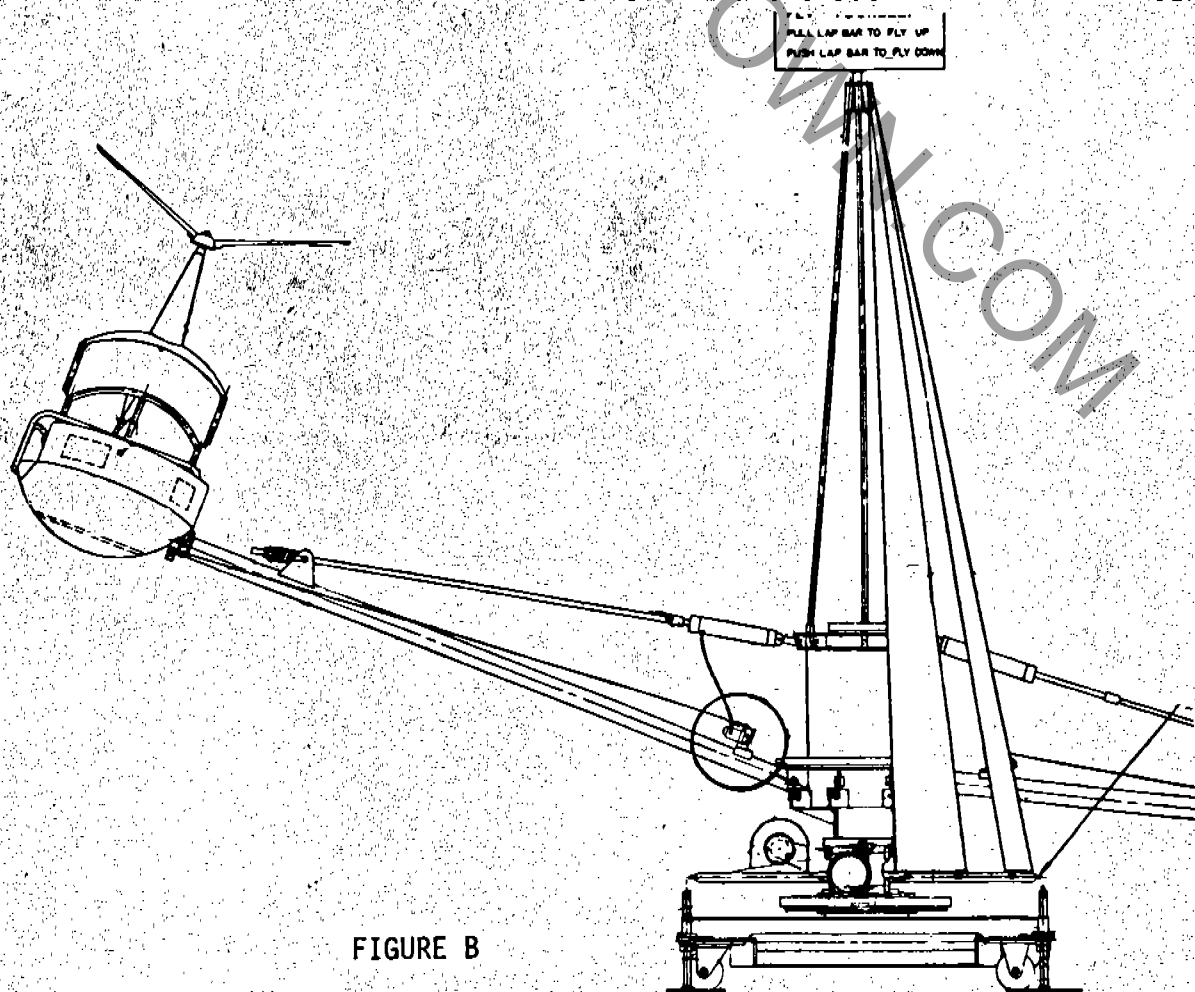

FIGURE B

INSTALLATION OF ORIFICE KIT

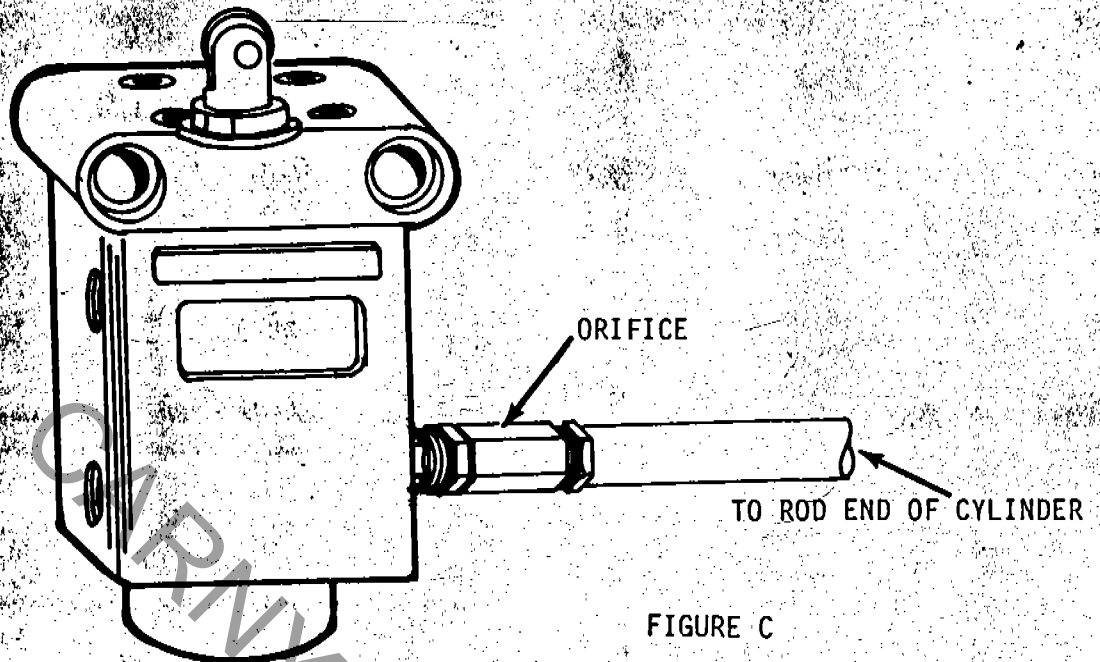

FIGURE C

Install the orifice kit as per Figure C and the following steps:

1. Disconnect hose coming from bottom of cylinder to valve (Vickers C-572) mounted on sweep.
2. Insert close nipple.
3. Insert orifice on close nipple.
4. Re-connect hose.

All work must be performed by competent, qualified mechanics capable of understanding the function of the parts and their proper installation.

CARNYTOWN.COM

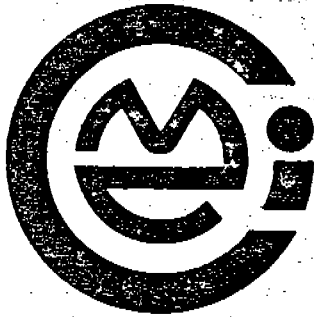

ALLAN HERSCHELL

CHANCE
MANUFACTURING CO., INC.

Number: 32
Date: 12-7-72

Superceeds:
Number: June 1969
Date:

Service Information

Ride: HELICOPTER RIDE

Subject: ERECTION AND CARE

REFERENCES:

Blueprints:

HCC-101 Assembly Dwg.
HC-100P Parts Numbers Dwg.
HC-153 Hydraulic Circuit Dwg.
KT-101 Foundation Drawing
HC-169 Wiring Diagram
HC-215 Oil Cylinder
Waterman Valve Print
Link Belt Parts List
Cutler Hammer Brake Information

Pamphlets: Keeping Hydraulic Systems Clean
Installation of Wesche Collector ring
Electric Circuit Diagram
Electrical Spec. Sheet
Packing List

Service Bulletins: Winter Storage
Lift Cylinders.

ERECTION AND CARE OF MODEL "C" HELICOPTER RIDE

1. Refer to print HCC-101 for general arrangement of parts and to print HC-100P for part number identification and lubrication instructions.
2. Select a spot that is reasonably level - especially for the center of the ride and the platform assembly. **NOTE:** Regrade, if necessary.
3. Place the center drive assembly into position so the motor extension cords will run in the direction of the switch box to suit the operator's convenience.
4. Level the center drive assembly by placing the level which is in the tool box, on top of the beams and using the four adjusting screws and ground plates. Tighten the lock nuts.
5. Attach the four platform tie rods to center base with bolts and lock numbers. The numbers on the tie rods should match the numbers on the center base.

Factory and General Office, 4219 Irving, Box 2397 Wichita, Kansas 67201

Area Code (316) 942-7411

Sales Office:

103 Ross Ave., Dallas, Texas 75202

Area Code (214) 742-3802

6. Assemble the 8 sweeps to the center with shafts and safety pins. The numbers on the sweeps must match the numbers on the center base.
7. Attach the 8 pull rods to hydraulic cylinders with tapered pins and safety pins. Hook the spring end of the pull rods into the ears on the sweeps with the grease fittings facing upwards.
8. Assemble the loading platform using taper pins and safety pins to lock in place. Add screw jacks at platform splices. The platforms are numbered.
9. Assemble Helicopter bodies to the sweeps with vehicle pins and safety pins. Use 3 "C" washers to fasten rotor post to top of the car - and the top of the car to the car body. Complete the vehicle assembly by adding tail post, tail fan and top rotor. The numbers on the vehicles must match the numbers of the sweeps. Adjust the nut on the pull rods to obtain a 6 inch clearance between the bottom of the car and the platform.
10. Attach the cables from the cars to the levers on the hydraulic cylinders after transferring the valves from their shipping mounts to the mounting brackets on top of the sweeps.
11. Assemble the "FLY YOURSELF" sign and the 8 banners to the top of the tripod. Lift the banners, sign and tripod to the top of the center drive unit and fasten with bolts and self-locking nuts. Attach the bottom of banners to circular pipe with "S" hooks.
12. Attach 4 light poles by driving tapered pins into pipe locks. Assemble the switch box to the light pole, matching numbers on the light poles to the numbers on the platforms.
13. Connect twist lock jumper cords from motor, light poles and magnetic valve.
14. Erect chain fence with the numbers on the fence posts matching the numbers on the platform. Outlet and inlet to the ride can be located in any of four places.
15. Check to see that all safety pins are in place and that all set screws are tight.
16. Lubricate the entire machine, with the exception of the reducer. Use SOCONY PD-1020A or SHELL RETINAX "A" (which are in the tool box) on the gear drive. When located near salt water, use FISKE BROS. LUBRIPLATE 630AA.

Lubrication - (continued)

A. Grease the lower bearings daily (6 fittings).
NOTE: Also see page 5.

B. Lubricate the top ball bearing with grease once a year. This requires removal of the top aluminum rain cover for access.

C. Oil and grease the sweep pins and tension rod sleeve weekly. NOTE: Check dwg. HC-100P for further and more detailed lubrication instructions.

D. Use MOBIL MP GREASE or KING GRAPHITE PRODUCT KGP-24.

NOTE: It is important that the commutator rings (under the rain cover) be kept clean. Brushes should be kept clean and free to slide in brush holder under spring pressure. Replace when worn or it will not operate.

17. At the Allan Herschell factory, the fluid drive sheave is given the proper amount of a premium grade of SAE 10-W oil. A change of oil is necessary every 5 years unless excessive slippage indicates that an earlier change is necessary. Check the oil level yearly. A slippage of 85 R.P.M. between the R.P.M. of motor and the R.P.M. of the hydrosheave is considered standard. The hydrosheave bearings are lubricated for life. The fluid drive sheave has the correct quantity of oil when it is positioned with its 2½ marking at the top center position which places the plug opening off center. Fill with proper fluid until the oil tends to run out the plug opening. Then, replace the pipe plug. Use gasket compound on plug threads.

18. VERTICAL SHAFT WORM REDUCER WV-35 (ceiling mounted).

A. Follow the instructions on the nameplate, using 600W in warm weather and 1/2 of SAE-40 and 1/2 of 600-W in cold weather. Maintain proper level.

B. Drain and refill after first 150 hours of operation.

C. Keep breather fitting clean and open.

NOTE: In locations where 600W is not available have your local supplier recommend a substitute.

During cold weather testing of these rides, the 600-W is too heavy, which throws an overload on the motor for starting after the machine has set idle for some time. In case this happens, start the ride, giving it a little help to get it up to speed and run it for 15 minutes. After this it will be free to run normally.

19. Check the V-belts on the drive for proper tension. When new, adjustments should be made frequently until the initial stretch has been taken up.

NOTE: These are not to be too tight and need very little attention during the season. CAUTION: Any adjustment of the belt drive should be done with the motor. Do not change the position of the gear reducer except to remove excessive backlash between the pinion and ring gear. Slide the pump base only to remove looseness in V-belts between the pump and motor.

20. CURRENT SUPPLY AND WIRING

Rides are wired as follows: See wiring diagram HC-169 Rev. 2.

1. When customer orders 1-phase, 3-wire, 115/230 volt supply, wiring is completed by us within the switch box for a single current supply by the customer.
2. When customer orders 3-phase, 4-wire, 208/120 supply, wiring is completed within the switch-box for a single current supply by the customer.
3. When customer orders 3-phase, 3-wire, 220 volt motor supply, a separate lighting supply must be provided of 115/230 volt, 3-wire, single phase. Wiring is completed within the switch box for these two separate current supplies by the customer.

ADEQUATE VOLTAGE MUST BE MAINTAINED
WITHIN 10% AT ALL TIMES.

21. OPERATING INSTRUCTIONS

- A. Move safety switch to "CN" position. This is normally left set at the "ON" position during the day's operation. (For quick stopping of the ride in case of an emergency, move to the "OFF" position.
- B. Move the main dump valve switch to "ON" position. This is a black handled switch located about 3 inches below the timer switch and permits the ride operator to lower the cars during rotation of the ride. Normally, it is left set at the "ON" position at all times.
- C. Move the timer to "ON" position, causing the ride to rotate only.

D. After 10 seconds PRESS the push button of the dump valve switch to "ON". (This push button switch is located to the right of the jog switch). This will make oil pressure available to the cylinders. The riders may then pull the lap bars to go up or push the lap bars to go down.

E. If the ride doesn't start - check the fuses.

F. Always use the timer delay type of fuses.

Cable adjustments may become necessary if the riders cannot rise after pulling on the lap bar. Eyebolts with long threaded shanks and jam nuts are provided for adjustment when necessary. Turning the eyebolts farther into the levers and tightening the jam nuts should overcome the difficulty.

MAINTENANCE OF HYDRAULIC SYSTEM

In the tool box is an extra coil for the solenoid of the dump valve. If the ride won't come down at the operator's demand, the cause is most likely to be a burned out coil due to low voltage, or a sticky valve and dirty oil. We suggest immediate replacement of the coil. Also, check the power supply line for low voltage and the condition of the oil.

The pressure gauge and pressure relief valve are furnished so that excessively high working pressures will not be imposed upon the motor and other parts of the hydraulic system. If the oil pressure in the system is too low, the vehicles will not rise. A gauge setting of 650 pounds is recommended as sufficient for even the heaviest loads. To check system pressure, open petcock at gauge. If necessary, the system pressure can be changed by operating the relief valve handle. Always turn off petcock after reading to prevent damage to gauge.

The intake oil filter and the air filter should be inspected and cleaned frequently, depending upon local conditions.

If the oil in the 50 gallon tank has become dirty, we suggest replacing it with 45 gallons of Socony DTE light oil, maintaining oil level between high and low marks on the dipstick. If oil has become excessively dirty, drain it, remove the two access doors on side of tank and clean all inside surfaces of the tank with kerosene. Apply Permatex #2 Formgasket compound to tank gasket, access doors and threads of capscrews before re-assembling.

MAINTENANCE OF HYDRAULIC SYSTEM (continued)

If it should ever become necessary to replace or repair any part of the hydraulic plumbing system, disconnect the large suction and return hoses at the top of the oil tank. This will eliminate a syphon effect and prevent all the oil in the tank from draining out on the ground.

Keep gauge valve closed except when reading gauge pressure. This will prolong the life of the pressure gauge.

MAINTENANCE OF LOWER CENTER BEARING

Once a year, grease should be softened by adding automotive flushing oil through fan opening and draining entire bearing through the bottom plug. Then, regrease weekly at the six grease fittings with Mobil MP Grease or King Graphite Product KGP-24. If this is not done, the old grease will oxidize, stiffen and separate and corrosion will follow.

WWW.TOWN.COM

S-4 217-0919-1-1
Sore
to force

INSTRUCTION SHEET For Bulletin 511 Type "S" 4" A-c Brake

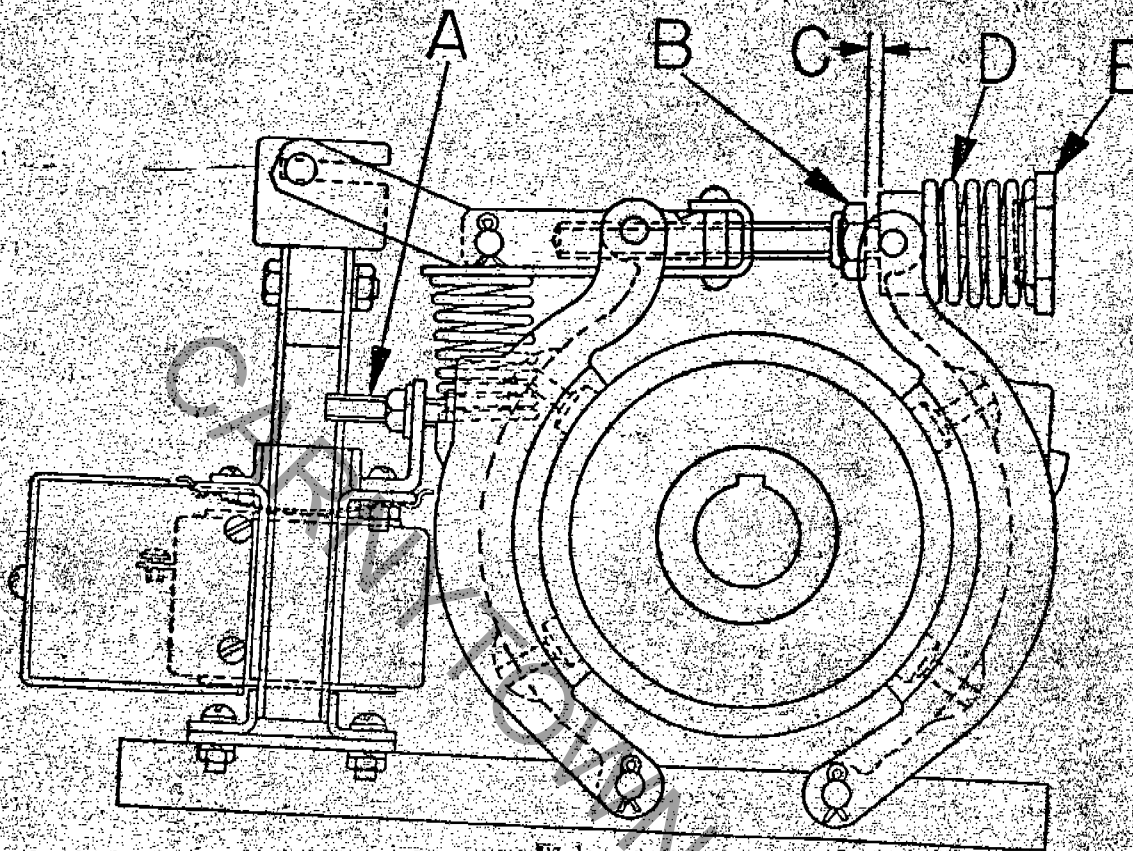

Fig. 1

INSTRUCTIONS (See Fig. 1)

1--MOUNTING: Clamp the brake on the wheel by compressing torque spring "D" by tightening the adjusting nut "E". Insert shims between the mounting stand and the base of the brake until the brake is setting solid on base.

2--ADJUSTMENT: a. Compress the torque spring "D" until the desired torque is obtained. The approximate compressed length of this spring, to obtain rated torque, is 1-1/16 inch. Further minor adjustment may be necessary.

While making this adjustment maintain a clearance

of 1/64" at "C" when the brake is applied. When the desired torque is obtained be sure that the clearance "C" is 1/64". The lock nut "B" will secure itself in this position.

b. Equalize the clearance between the shoes and wheel when the brake is released by setting screw "A".

3--RE-ADJUSTMENT: When the lining wears, the clearance "C" decreases. Never permit this clearance to become zero since complete loss of braking torque will result. When the clearance "C" becomes low, again adjust to 1/64" by turning screw "E". No change in torque will result from this adjustment if nut "B" is not changed.

Torque Rating	Compressed Length of Spring "D"
10 Lbs. Ft.	1-1/16"

CARNYTOWN.COM



Bulletin No. _____
December 1965
Date _____

ALLAN HERSCHELL COMPANY

Division of Lisk-Savory Corp.

1165 CLINTON STREET

BOX 465

BUFFALO, NEW YORK 14240

AREA CODE 716 825-8300



Service Bulletin

Ride ~~HELICOPTER RIDE~~

Subject ~~LIFT CYLINDERS~~

File _____

Refer to print HC-215 showing cylinder parts.

In time, through normal wear, it will become necessary to replace the packing washers (No. 5070-20) in the hydraulic lift cylinders of your Helicopter Ride.

The packing washers should be replaced whenever excessive oil leakage is noted around the piston rod.

NOTE: There should be a sufficient amount of oil by-passing the packing washers for normal lubrication of the piston rod.

The tools and parts necessary to do this job are available from Allan Herschell Company.

NEOPRENE PACKING
WASHERS: - 3 required per cylinder.

TOOLS: - 1 protector sleeve
1 driving tool
1 spanner wrench

The following is a step by step procedure for the installation of the packing washers. Use this procedure, referring to print HC-215 for the correct identification of the parts and for the order that they are to be assembled.

1. Disconnect tension rod at clevis pin.
Remove the clevis and piston rod nut.
2. Disconnect supply line cylinder. (To prevent loss of oil, keep end of line above oil level in tank).

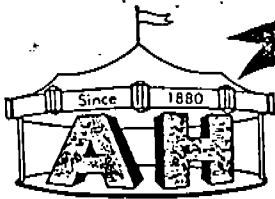

ALLAN HERSCHELL COMPANY INC.

BOX 465 • 1165 CLINTON STREET • BUFFALO 5, NEW YORK

AREA CODE 716 -- TA 5-8300

Service Bulletin

Ride Helicopter

Subject Replacing lower bearings
of Helicopter

File _____

Re: Blueprint HC-190 Revision E
Conversion Lower Bearing
Blueprint HC-100FC
Parts Numbers & Lubrication

INSTRUCTIONS FOR REPLACING LOWER BEARINGS OF HELICOPTER

1. Disconnect main power supply at switch box. This is important for safety since internal electrical connections will be worked on.
2. Remove all vehicles, sweep rods and tension rods from center section. The hydraulic lift cylinders and fittings should be left in place.
3. Remove banners and banner supports.
4. Remove large aluminum rain cover (HC-128) from top of center section by removing 3 round head machine screws and lifting cover.
5. The top of electrical commutator is now exposed inside the top of center section. It is important to make a written diagram showing the color and size of the electrical wires and their position to the numbered connections on the commutator. This will be used when the wires are replaced on the commutator. Disconnect wires and tie with a 20' length of heavy string or wire so the BX cable may be retrieved if it drops into the center section.
6. Leave the wires connected to the brush finger stand and remove entire brush assembly by removing the 2-5/8" bolts in the base and lifting assembly.
7. Loosen the 2 Allen set screws on the commutator ring (feel with finger between brass grooves) and lift commutator to remove.
8. Loosen the single set screw in commutator shaft to free the BX cable harness inside. Make certain the 20' string or wire is secured to top of wire harness and tied to the top of center section to prevent cable from dropping down into the bottom of the tank.
9. Remove the 4 1/4" Allen screws holding the commutator shaft and lift out shaft. Make certain the BX cable does not drop into the center section tank unless secured by wire or string.
10. Using two screw drivers expand and remove the snap ring now visible.

b. The "H" cross section meehanite bearing (HC-191) is raised into position from below with the six bolts projecting through the six holes drilled in the casting. It may be necessary to slightly rotate or "jockey" the bearing until all six bolts project through their proper holes. Apply the six Flex-lock nuts on the bottom of the bolts. With an end wrench very securely tighten the spacer nuts above the bearing since these six bolts support the entire assembly. Now tighten the six Flex-lock nuts with a socket wrench. The oil tank part of the new bearing assembly is now complete.

c. On the sub-base unit which was not moved the 10 bolts supporting the old meehanite bearing must be removed and thrown away since they must not be used again. Lift or force up old bearing and discard.

d. VERY THOROUGHLY AND COMPLETELY CLEAN ENTIRE BEARING AREA OF ALL DIRT, GRIT AND OLD GREASE.

e. Install the new meehanite bearing (HC-194) and bronze sleeve bearing (HC-204) with the groove on top using the 10 new Allen head cap screws 5" long and Flex-lock nuts furnished. Insert the 6 grease fittings and 2 pipe plugs in the new outer bearing if not already assembled. With a grease gun force Socony MP automotive chassis type grease into the six fittings until grease flows over bronze sleeve bearing and fills all bearing channels. Pack about three gallons of this same grease into bearing well until it fills space to the level of the grease gun fitting openings in the bronze sleeve bearing. This completes the replacement of the old style (HC-123) #1 type bearing to the new #3 type bearing assembly.

f. Replacement of #2 type bearing with the new #3 type assembly. This is a simple operation since the six motor base mounting bolts are not removed and they require only new Flex-lock nuts. The #2 type of bearing is similar in appearance to the new #3 (HC-194-1), but must not be interchanged or old parts of the bearing used again.

a. Remove the six Flex-lock nuts from the underside of the old "H" cross section meehanite bearing and remove the bearing which must not be used again. Raise the new bearing into the same position and secure with six new Flex-lock nuts.

b. Remove the old outer steel casting shell and replace with the new meehanite bearing (HC-194-1). The same 10 bolts may be used but new Flex-lock nuts must be secured. Place the bronze sleeve bearing (HC-204) in position with groove up.

c. VERY THOROUGHLY AND COMPLETELY CLEAN ENTIRE BEARING AREA OF ALL DIRT, GRIT AND OLD GREASE.

d. Insert the 6 grease fittings and 2 pipe plugs in the new outer bearing if not already assembled. With a grease gun force Socony MP automotive chassis type grease into the six fittings until grease flows over bronze sleeve bearing and fills all bearing channels. Pack of this same grease into bearing well until it fills space to the level of the grease gun fitting openings in the bronze sleeve bearing. This completes the replacement of the old style (HC-194-1) #2 type bearing to the new #3 type bearing assembly.

SELECTION TABLE — AGMA. LUBRICANT NUMBERS

DRIVE TYPE	AMBIENT TEMPERATURE			OIL CHANGES	
	0° TO 40°F. USE AGMA NO.	41° TO 100°F. USE AGMA NO.	101° TO 150°F. USE AGMA NO.	IN HOURS	
				INITIAL	PERIODIC
ROLLER CHAIN	2	3	5	500	2500
SILENT CHAIN					
P.I.V. VARIABLE SPEED ▲	3	7■	8■	150	2500
V.R.D. VARIABLE SPEED	1	3	5	150	2500

DRIVE TYPE	AMBIENT TEMPERATURE		OIL CHANGES	
	15° TO 60°F. USE AGMA NO.	50° TO 125°F. USE AGMA NO.	IN HOURS	
			INITIAL	PERIODIC
IN-LINE MOTOGEAR GEARMOTOR ELECTROFLUID MOTOGEAR	2	4	150	2500

PARALLEL SHAFT UP TO 1800 RPM					
H-41 TO HD-36 TO HT-41 TO	H-81 HD-61 HT-61				
		2	3	150	2500
H-101 TO	H-180				
		2	4	150	2500
HD-70 TO HT-70 TO S-200 TO D-150 TO	H-130 HT-130 S-330 D-250				
		3	4	150	2500
T-150 TO	T-250				
		4	5	150	2500
1800 TO 3600 R.P.M. ALL SIZES ABOVE		2	3	150	2500
OVER 3600 R.P.M. ALL SIZES ABOVE		1	2	150	2500

WORM GEAR					
UP TO 6" CTRS.					
* WORM SPEED UP TO 700 R.P.M.		7 COMP.	8 COMP.		
* WORM SPEED OVER 700 R.P.M.		7 COMP.	8 COMP.	150	2500
OVER 6" CTRS. TO 12" CTRS.					
* WORM SPEED UP TO 450 R.P.M.		7 COMP.	8 COMP.	150	2500
* WORM SPEED OVER 450 R.P.M.		7 COMP.	7 COMP.		
OVER 12" CTRS. TO 18" CTRS.					
* WORM SPEED UP TO 300 R.P.M.		7 COMP.	8 COMP.	150	2500
* WORM SPEED OVER 300 R.P.M.		7 COMP.	7 COMP.		
SPIRAL BEVEL GEAR		3	5	150	2500

■ NQ.7 TO BE STRAIGHT MINERAL OIL OF SAME VISCOSITY AS NO.7 COMP.
 NQ.8 TO BE STRAIGHT MINERAL OIL OF SAME VISCOSITY AS NO.8 COMP.

* WORM SPEED IS THE R.P.M. OF THE INPUT SHAFT ON SINGLE REDUCTION DRIVES AND THE R.P.M. OF THE SECONDARY WORM SHAFT ON DOUBLE REDUCTION DRIVES.

AGMA LUBRICANT NUMBERS SHOWN IN THE ABOVE TABLE APPEAR ON INDIVIDUAL NAMEPLATES ATTACHED TO POWER TRANSMISSION DRIVES OR CASINGS. REFER TO DWG 342Y171 FOR LISTING OF NAMEPLATES.

POUR POINT OF LUBRICANT MUST BE LESS THAN THE AMBIENT TEMPERATURE —
 SEE DATA SHEET 342Z151

▲ SEE DATA SHEET 342Y170, FOR TYPICAL MANUFACTURER'S OILS.

Book No.

DATE	REV.	3-4-57	9-5-57	LINK-BELT COMPANY	342Y152
1-25-57					