

*Perates Cave*

*D4073  
03147*

*03147*

Can-Am Go Kart Inc.

Go-Kart

Non-Kiddie

*TAC*

# Can-am Go-Kart, Inc.

## Go-Kart Manual

234 Clements Rd. West, Unit #1  
Ajax, Ontario, Canada  
L1S 3K5

Parts (only) : 800-295-3707

Fax : 905-683-9828

Karts : 800-355-5278

Service : 905-683-9700

**!!!!!!!!!!!!!!!!!!!!**

**IT IS THE  
RESPONSIBILITY OF  
EACH AND EVERY TRACK  
OWNER TO OBTAIN ALL  
OPERATING LICENSES  
AND PERMITS AS  
SPECIFIED AND  
REQUIRED BY LOCAL,  
STATE / PROVINCIAL AND  
FEDERAL LAWS !**

**!!!!!!!!!!!!!!!!!!!!**

**\* \* \* WARNING \* \* \***

**READ**

**HONDA OWNER MANUAL**

**AND**

**THIS MANUAL**

**CAREFULLY**

**BEFORE OPERATION  
OF ANY  
EQUIPMENT**

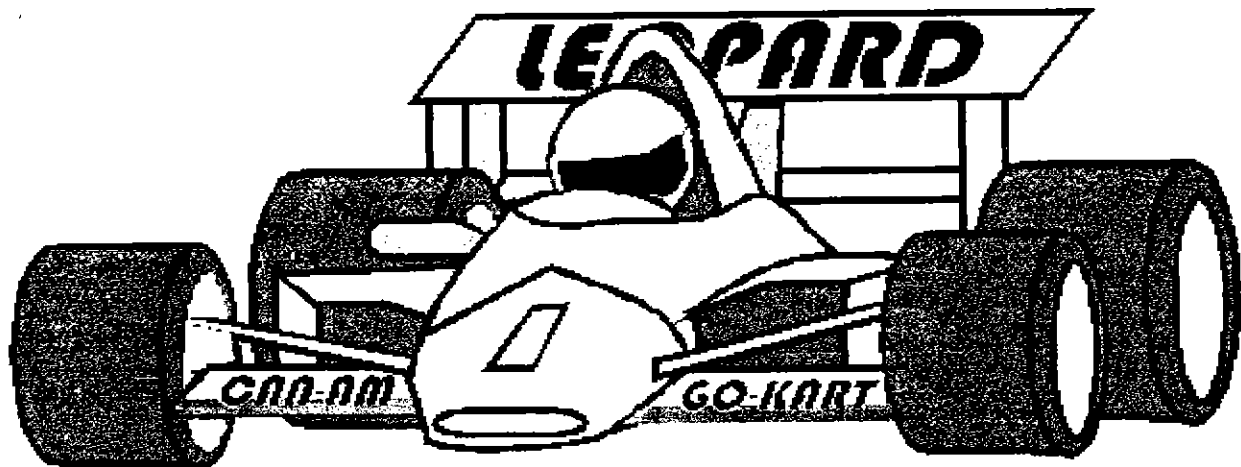

**Dear Kart Owner:**

**There are a few things you should do before you start running your kart.**

- \* Add oil and gas. Remember there are two spots for oil (in the R.D. gear box and in the engine block).**
- \* Hand check all nuts and bolts to ensure nothing is loose.**
- \* Attach the steering wheel and wings as shown in picture.**
- \* Apply all decals. DO NOT apply Armorial until after decals are in place.**
- \* We recommend (like a new car) that you do the first oil change within the first week.**
- \* After initial break in (one week) you should fleet check your karts to ensure belt tension is correct (1/4" play in belt) and all nuts and bolts are secure.**
- \* We recommend that you start a REGULAR maintenace schedule on all your vehicles to ensure years of revenue making.**

## **CAN-AM CONCESSION KARTS**

<b>MODEL #95</b>	<b>LYNX</b>
<b>MODEL #32</b>	<b>WILDCAT</b>
<b>MODEL #75</b>	<b>TIGERCAT</b>
<b>MODEL #48</b>	<b>COUGAR</b>
<b>MODEL #55</b>	<b>CHEETAH</b>
<b>MODEL #77</b>	<b>JAGUAR</b>
<b>MODEL #74</b>	<b>LEOPARD</b>

This service manual has been prepared as a guide for the mechanic servicing the above models.

All information in this publication is based on the latest product information available at the time of publication. We reserve the right to make changes at any time without prior notice.

The concession model go-karts are designed to withstand the wear and tear required by a concession kart, but like all good equipment, they require a scheduled maintenance program. Following the guide lines of this manual will not only insure the safe, efficient operation of the kart, it will also enable the mechanic to recognize potential problems before they happen, thereby insuring that your kart will operate at its potential during your money-making hours of operation.

## DAILY MAINTENANCE CHECK

1. Tire check - ensure tires are not showing cord.
2. Crankcase oil. (40 weight oil)
3. Ensure brakes are operating properly. **Do not use automotive brake fluid in brakes!**
4. Ensure accelerator operates properly - make sure it does not stick!
5. Test steering to ensure kart turns properly each way.
6. Body bolts - check to make sure they are secure.
7. Wipe down bodies.

## WEEKLY MAINTENANCE CHECK

### FRONT ENDS

1. King pins and spindles.
2. Tires - wear, air pressure and wheel bolts.
3. Wheel alignment.
4. Grease and oil all moving parts.

### REAR ENDS

1. Belt tension.
2. Axle bearings.
3. Brakes.
4. Air filter.
5. Spark plugs.
6. Tires - wear, air pressure and wheel bolts.
7. Veri hub.
8. Drive gear and washer.
9. Throttle linkages.
10. Oil levels - crankcase (and RD case).
11. Motor mount bolts.

## THE BODY

The body of the concession go-kart is constructed of a special polyethylene. To maintain the cosmetic appearance of the body, we suggest an "Armor All" type protectant. (We have tried various different brands of this type of product and have found products made by ZEP INDUSTRIES and EAGLE 1 or ARMOR ALL to be the most economical). By simply filling a 12oz. bottle and spraying it onto the bodies, then using a clean rag to wipe all the exposed portion of the body, you will restore a shine to the surface.

## BODY FASTENING

The body of the kart is bolted to the frame of the kart in three or four places. Two located at the rear of the kart and one or two located at the front. To remove the body, simply remove the body nuts.

## SURFACE PREPARATION - DECAL APPLICATION

Before applying the decals to the polyethylene kart body, the following procedures should be followed:

1. Remove all surface dust and dirt, using soap and water; dry with a clean cloth.
2. Saturate a clean cloth with LACQUER-THINNER\* or NAPHTHA\* (**DO NOT USE OTHER SOLVENTS!**) and wipe the area where decal is to be applied. Dry the surface before the solvent evaporates.
3. Using a propane torch, and exercising care and caution, pass a flame lightly over the surface. Ensure that the flame does not dwell on any location to damage or melt the plastic.
4. Test the treated area by applying some water. If properly prepared, the water will "sheet" rather than form beads.
5. Ensure the surface is clean and dry and **COOL!** then carefully apply decal.

\*Additional care must be taken with painted bodies. Do not allow solvents to touch the painted surfaces and use propane torch only on unpainted areas.

## TIRES AND TUBES

The tires should become part of a daily maintenance check. Each morning before operating your karts you should conduct a visual inspection of the front and rear tires. Should the cords of the tire be showing, replace the tire. This will eliminate tube consumption and down time during busy periods due to a flat tire.

<b>RECOMMENDED TIRE PRESSURES</b>	340 OR 410 x 5 FRONT	20-28 lb.
	11 x 600 x 5 REAR	24-32 lb.
	16 x 650 x 8	16-24 lb.
	18 x 950 x 8	16-24 lb.

(NOTE: LOWER PRESSURE IN COOL TEMPERATURE, i.e. 50°F,  
INCREASE PRESSURE WHEN HOT, i.e. 80°F OR MORE)

### OIL CHECK/CRANKCASE (40 weight oil)

Fill the crankcase with oil through the gray plug at the bottom of the side cover. To ensure that your engine does not run dry of oil you should check the oil each and every running day. The oil should be filled until oil is visible on the bottom of the threads on the sidecover. Refer to HONDA Engine Owner Manual.

### OIL CHECK RD BOX

Check the oil level in your weekly maintenance schedule. See HONDA Owner Manual. (40 weight oil)

## SPARK PLUG

During your weekly maintenance check, it is a good idea to remove the spark plug and clean it, or if necessary, replace it. At the same time, ensure that the plug cap is 0.02-0.03 in. The gap of the plug is pre-set on NGK plugs but upon occasion does require adjustment.

## AIR CLEANER

Cleaning the air filter element during your weekly check is also a good idea. You should wash the element in a detergent and then dry. If you have access to an air compressor it is often adequate to simply blow the element from the inside and re-install. (Refer to HONDA Engine Owner Manual).

### **DRIVE GEAR (Belt Drive Only)**

The drive gear located on the crankshaft requires little maintenance. During your weekly maintenance check, you should ensure the drive gear is fastened securely and the washer is tightly fastened as well. Should the washer not be in place, the belt will shift resulting in either the belt coming off the gear or shredding the belt. The gear should also be tightly secured or it may shift resulting in the belt slipping or tearing.

### **BELT**

Maintain no more than 1/2" movement. Preferably as tight as you can. **IMPORTANT:** You will be required to adjust belts with the first two hours of operation. If an adjustment becomes necessary, for what ever reason, then you will be required to loosen the motor mount bolts and slide the whole engine in the appropriate direction. These bolt are located on the four corner of you motor mount and are easily loosened with a 1/2" wrench. A loose belt will quickly destroy the belt in a few hours.

### **VERI HUB : REDUCTION DRIVE BELT**

If your concession kart is equipped with a reduction drive, with a belt, then your veri hub will have a large gear on it which the belt rides. It is important to make sure that the belt is running on the entire width of the gear to increase the longevity in the life your belt. The position of this gear depends upon where your veri hub is positioned on the axle. To move the veri hub, loosen the Allen bolts and tap it with a hammer in the necessary direction and secure it.

### **CARBURETOR**

In the event of carburetor problems, either because of dirt or water, it will become necessary to disassemble the carburetor. The float chamber then should be thoroughly cleaned and the main jet removed. This is done by inserting a small screw driver in the body of the carb, then flipping the carb upright and tapping the body until the main jet falls out. This can be cleaned by blowing air through it. The float is held in place by a small pin which can be removed by simply pushing it out. During re-assembly finger push to check for free movement of the float.  
**FOR ALL OTHER ENGINE REPAIRS PLEASE CHECK YOUR HONDA SHOP MANUAL. (AVAILABLE THROUGH A HONDA DEALER)**

### AXLE BEARINGS

All concession karts run a live axle (4 bearing) or split axle (6 bearing) drive system. It is very important to ensure these bearings remain tightly fastened to both the axle and the frame. This can be done by ensuring that all bolts are secured and that the set screws located on the bearing are tightly secured as well.

This maintenance procedure should be included in the weekly maintenance check. Should you fail in doing so, the axle bearing will eventually begin to spin on the axle. This often results in the axle heating up at the point and it may eventually break. In the event of this happening, you are faced with replacing not only the broken or bent axle but the bearing as well. This job (replacing the axle) is both expensive and time consuming as it requires removing all parts from the axle and placing them back on the new axle.

### BRAKE ADJUSTMENT (MECHANICAL 1991 & OLDER) COUGAR, WILDCAT AND TIGERCAT

The kart is outfitted with a disc brake system. This type of system requires some maintenance after use. The brake pucks do wear out, much the same as on any car, and need adjustment from time to time. To do this adjustment, loosen the jam nut located on the brake casing - turn the bolt in until a slight resistance can be felt when the axle is turned by hand. Retighten jam nut.

Periodic inspection should be made of the pucks also the prevent possible damage to the brake disc. (See sketch Fig. 2:1)

### HYDRAULIC BRAKES

#### DO NOT USE AUTOMOTIVE BRAKE FLUID!

Owners of karts purchased after August 1991 (All Leopards) are equipped with a hydraulic disc brake system. Use only a mineral oil brake fluid, NOT AUTOMOTIVE FLUID! Recommended fluid is available through the parts desk.

Puck Gap - Use 1/3" Allen wrench to turn adjuster bodied evenly for desired pad gap.

Puck Removal - Remove caliper from disc, use 3/16" Allen wrench to remove and replace puck. (See Fig. 3:2)

#### USE ONLY MINERAL BASED BRAKE FLUID!

**WARNING !! DO NOT USE AUTOMOTIVE BRAKE FLUID**

# MECHANICAL BRAKE SYSTEM

FIG. 2:1

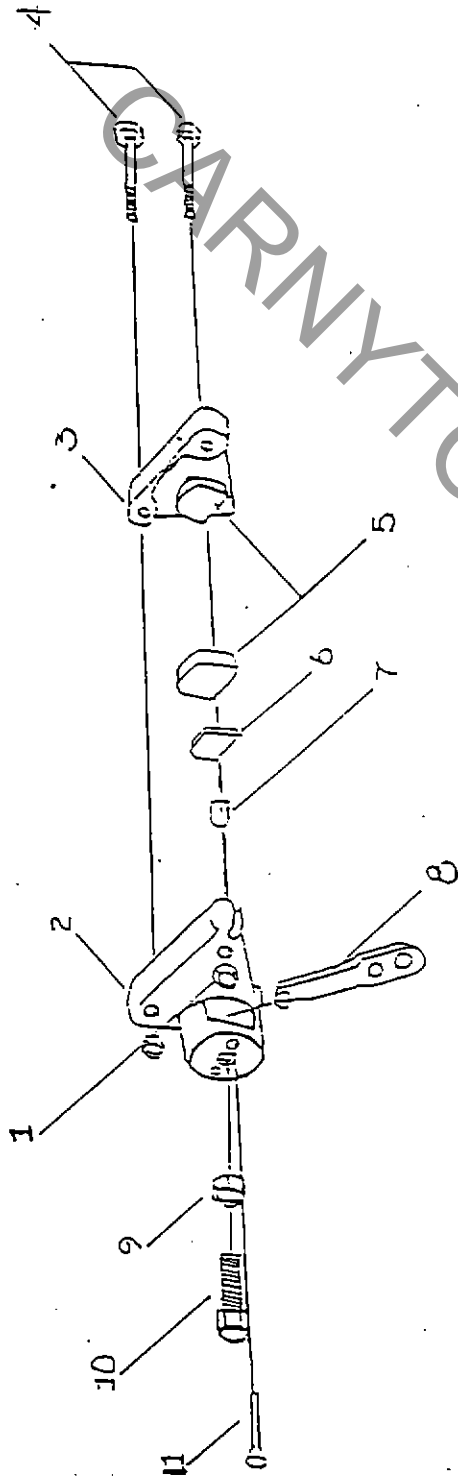

- MECHANICAL BRAKE CALIPER ASSEMBLY
1. NUT
  2. BRAKE OUTER
  3. BRAKE INNER
  4. HEX HEAD BOLT
  5. BRAKE PUCS
  6. BACKING PLATE
  7. PUSH PIN
  8. BRAKE LEVER
  9. JAM NUT
  10. ADJUST. BOLT
  11. GROOVE PIN

FIG 2:2

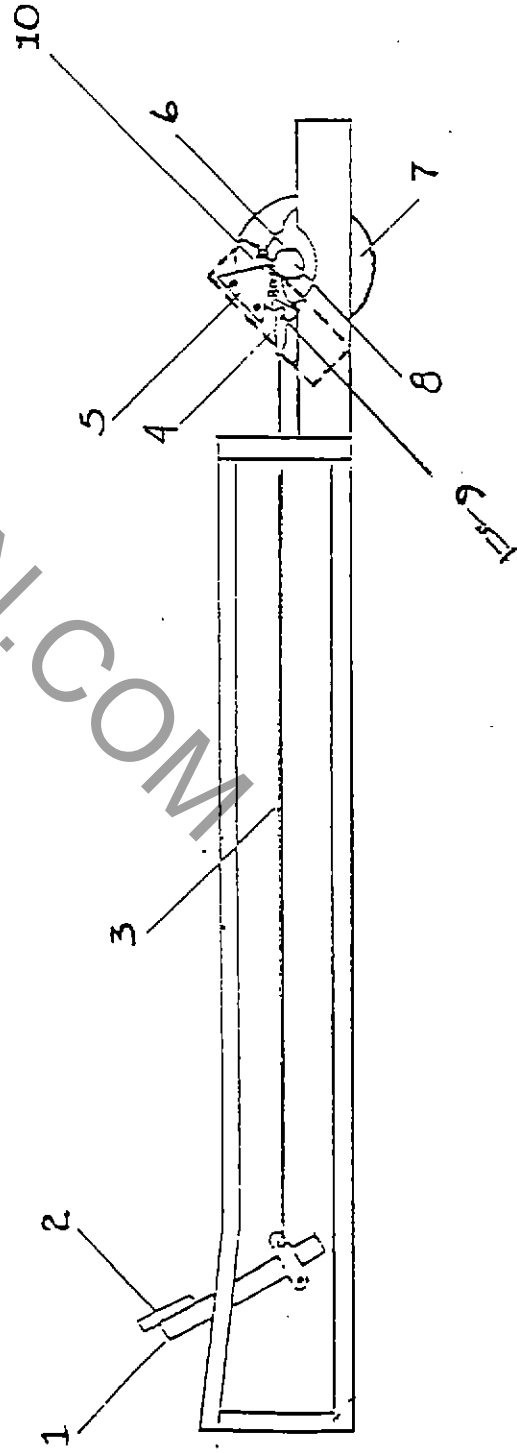

- MECHANICAL BRAKE SYSTEM
1. BRAKE PEDAL
  2. BRAKE PEDAL PLATE
  3. BRAKE ROD
  4. BRAKE CLEVIS
  5. COMP. BRAKE CALIPER
  6. PILLOW BLOCK BEARING
  7. BRAKE DISC
  8. AXLE
  9. CLEVIS PIN
  10. BRAKE RETURN SPRING

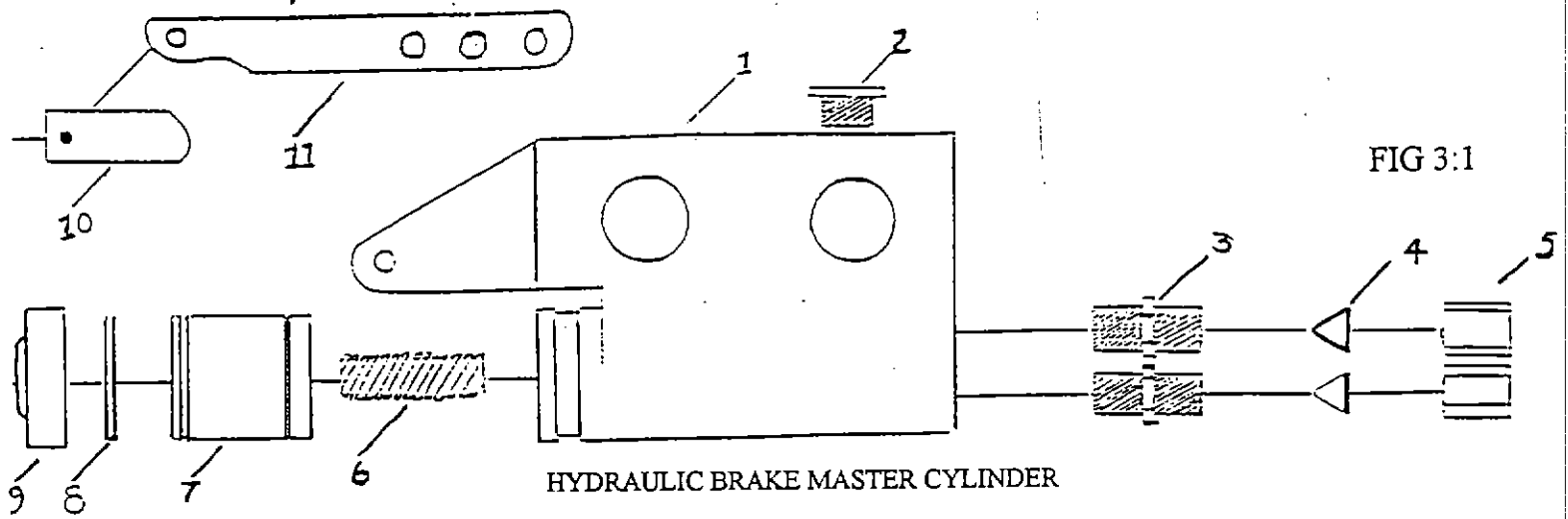

FIG 3:1

HYDRAULIC BRAKE MASTER CYLINDER

- |                         |                      |
|-------------------------|----------------------|
| 1. MASTER CYLINDER BODY | 7. PISTON            |
| 2. FILL CAP             | 8. PISTON SEAL       |
| 3. CABLE FITTING        | 9. RUBBER OUTER SEAL |
| 4. CABLE FITTING        | 10. ACTUATOR PIN     |
| 5. FITTING CAP          | 11. ACTUATOR ARM     |
| 6. RETURN SPRING        |                      |

**WARNING : DO NOT USE AUTOMOTIVE BRAKE FLUID**

FIG 3:2      FIG 3:3

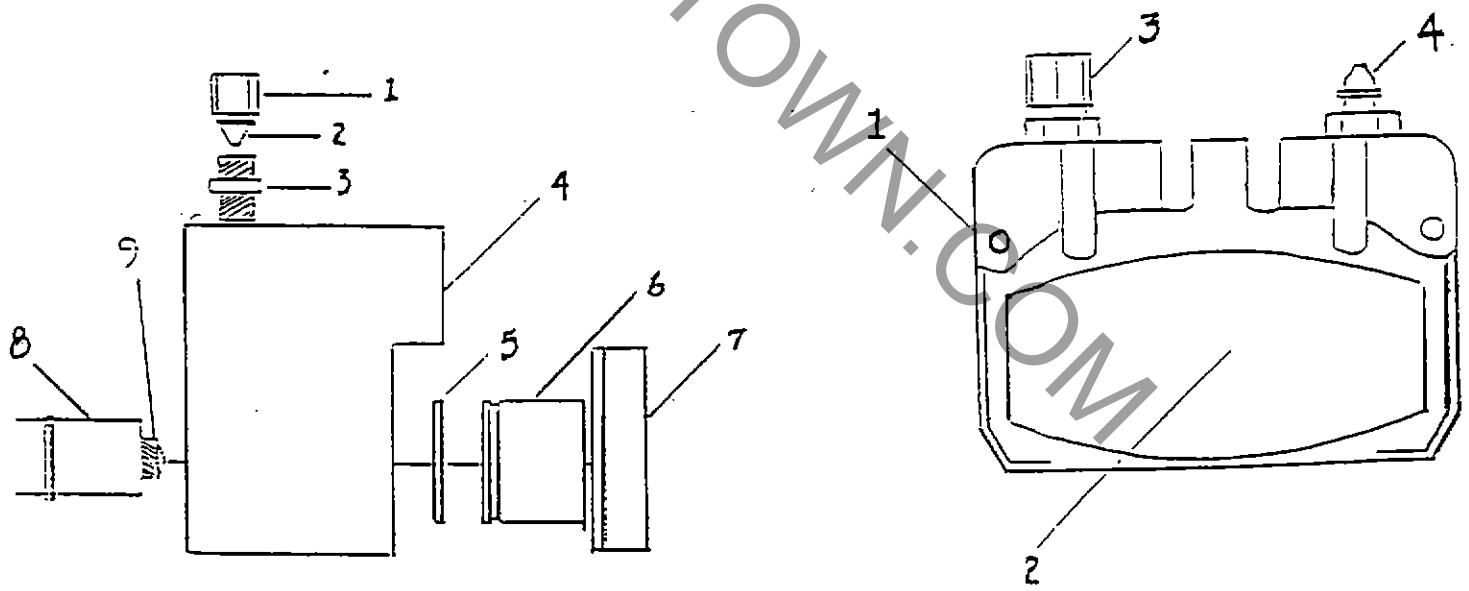

HYDRAULIC BRAKE CALIPER (SIDE VIEW)

- |                        |                    |
|------------------------|--------------------|
| 1. FITTING CAP         | 6. CALIPER PISTON  |
| 2. FITTING FERRULE     | 7. BRAKE PUC       |
| 3. CABLE FITTING       | 8. ADJUSTMENT BODY |
| 4. CALIPER BODY        | 9. BRAKE PUC SCREW |
| 5. CALIPER PISTON SEAL |                    |

HYDRAULIC BRAKE CALIPER (FRONT VIEW)

- |                        |
|------------------------|
| 1. CALIPER BODY        |
| 2. BRAKE PUC           |
| 3. COMP. CABLE FITTING |
| 4. BLEEDER VALVE       |

**WARNING!!! DO NOT USE AUTOMOTIVE BRAKE FLUID!**

## FRONT END ALIGNMENT

Place the steering to the center position. Then mark a chalk line on the center of the tires.

Next, measure the distance from the center of one tire to the center of the other tire (hereafter known as measurement "1"). Then rotate the tires 180° and measure (from the back of tires) the center on one tire to the center of other tire. (Hereafter known as measurement "2"). Should the distance between measurement "1" and measurement "2" vary by more than 1/4" then you will be required to make an adjustment. This can be done by unbolting the tie rod ends from the spindles and winding the tie rod end in or out depending on your situation. Should measurement "1" be a shorter distance than measurement "2" then turn the tie rod ends out on the tie rods. It is important, however, that you split the distance between the two sides.

NOTE: EACH FULL (360 DEGREE) TURN OF THE TIE ROD END ON THE TIE ROD IS EQUAL TO APPROXIMATELY 1/8" DIFFERENCE IN THE TOE-IN OF THE TIRE.

EXAMPLE:            MEASUREMENT "1"    =    34"  
                         MEASUREMENT "2"    =    36"

Therefore, you must bring both wheels out by 1". Half an inch on the left side and half an inch on the right side. Unfasten the tie rod ends located on the spindles and turn them out four turns and re-secure them to the spindle.

Should measurement "2" be smaller than measurement "1" then you must do exactly the opposite.

EXAMPLE:            MEASUREMENT "1"    =    36"  
                         MEASUREMENT "2"    =    34"

You must therefore turn the tie rod ends in on the tie rods four turns on each side to correct the problem.

Ensure camber on front wheels are correct by using a square. If you have to adjust, simply remove spindle yoke bolt, adding a flat washer to each of the upper or lower bolts between the frame and the spindle yoke to insure wheel and tire are 90° from ground.

To ensure optimum steering ease and handling, the spindles are mounted to spindle plates on the frame with the use of four (4) bolts. The bolts can be loosened to allow a quick height adjustment, and then re-tightened when the desired setting is reached. This procedure should be done if you notice a kart "pulling" to one side.

## ACCELERATOR SYSTEM - ADJUSTMENT

There are two procedures which may be used to adjust speed on your kart.

1. By moving cable locks , Fig. 1:1 #6  
i.e. moving front cable lock forward will slow kart,  
moving back will increase speed.

OR

2. Moving accelerator adjustment pin, Fig. 1:1 #3  
i.e. moving pin in (toward cable swivel) will slow kart,  
moving back will increase speed.

### NOTE

Both operations may be required to adjust speed and idle properly. If any problems occur, do not hesitate to contact the Service Department.

### STEERING

The complete steering system should be checked weekly for wear and damaged parts. Lubricate tie rod ends and steering shaft bushings weekly to ensure the system does not bind or premature wear does not occur.

**IT IS VERY IMPORTANT TO ENSURE THAT THE STEERING WHEEL LOCK NUT IS SECURELY TIGHTENED. AS PART OF YOUR NORMAL MAINTENANCE PROGRAM, THIS SHOULD BE CHECKED AT REGULAR INTERVALS!**

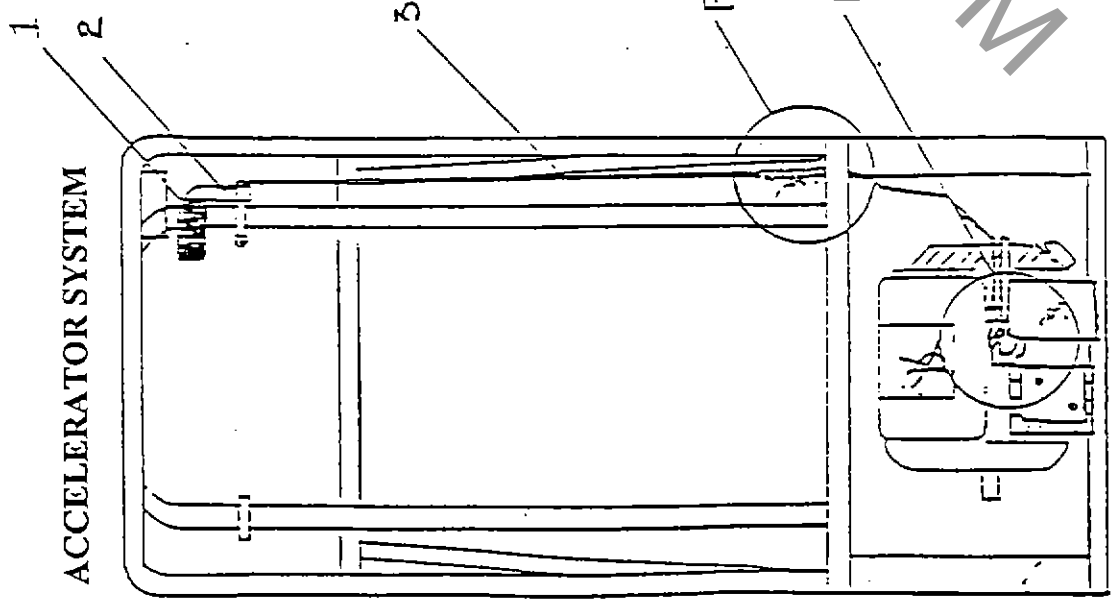
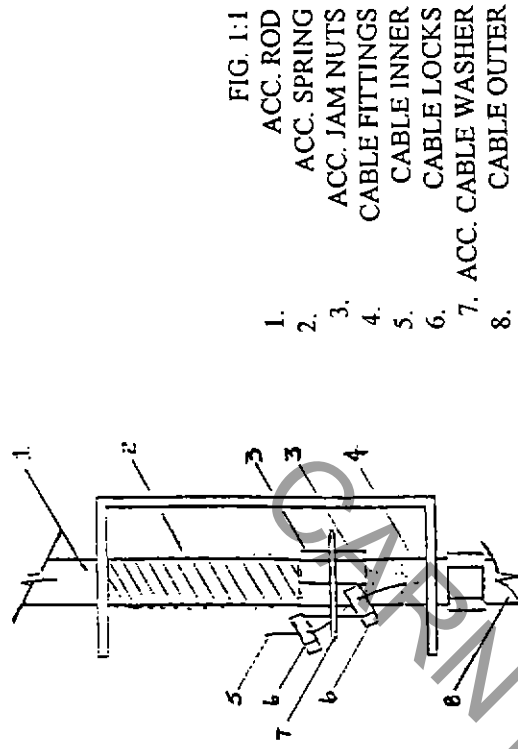

FIG. 1:1



- FIG. 1:1
- 1. ACC. ROD
  - 2. ACC. SPRING
  - 3. ACC. JAM NUTS
  - 4. CABLE FITTINGS
  - 5. CABLE INNER
  - 6. CABLE LOCKS
  - 7. ACC. CABLE WASHER
  - 8. CABLE OUTER

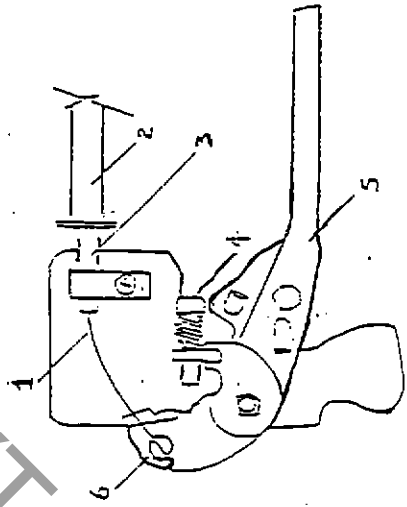

FIG. 1:2

- 1. CABLE INNER
- 2. CABLE OUTER
- 3. ADJUSTMENT PIN
- 4. THROTTLE ADJUST. SCREW
- 5. THROTTLE ARM
- 6. CABLE SWIVEL

- ACCELERATOR SYSTEM
- 1. ACC. PEDAL PLATE
  - 2. ACC. PEDAL
  - 3. ACC. ROD

**REMEMBER**

**THE ACCELERATOR SYSTEM, THE BRAKING SYSTEMS  
AND THE STEERING SYSTEM ARE THE MOST IMPORTANT  
AREAS FOR FOR YOU TO SERVICE AND ENSURE YOUR  
CUSTOMER'S SAFETY.**

**THESE NEED TO BE CHECKED REGULARLY!**

**GENERAL OPERATION SAFETY**

**DO NOT - REFUEL KART WHILE ENGINE IS RUNNING!**

**DO NOT - REFUEL KART WHILE CUSTOMER IS SEATED  
IN KART!**

**ALSO MAKE SURE FIRE EXTINGUISHERS ARE ON HAND**

**IF YOU HAVE ANY PROBLEMS OR QUESTIONS ABOUT ANY  
PRODUCTS, PLEASE CONTACT OUR SERVICE  
DEPARTMENT.**

## ENVIRONMENTAL NOISE ANALYSIS

LOCATION	DISTANCE CORRECTION DROP IN SOUND OVER DISTANCE FROM SOURCE	TRACK EFFECT ALLOWANCE FOR SOURCE NOT BEING IN CONSTANT SPOT	GROUND ATTENUATION FACTOR, SOUND ABSORBED BY GRASS, TREES, ETC OVER DISTANCE TO LOCATION	LEQ (dB FOR INDICATED #				
				1	10	15	30	50
A) 300' from noise source	-16Db	-8	No ground attn. Gr attn. factor - 2	46	56	58	61	63
B) 750' from noise source	-24Db	-5	No ground attn. Gr. attn. factor - 8	41	51	53	56	58
C) 1000' from noise source	-26Db	-4	No ground attn. Gr. attn. factor - 10	30	40	42	45	47
D) 1250' from noise source	-28Db	-3	No ground attn. Gr attn. factor - 12	27	37	39	42	44
E) 1350' from noise source	-29Db	-2	No ground attn. Gr. attn. factor - 14	26	36	38	41	43

**A) LOCATION**

Measuring devices were placed the indicated number of feet from edge of track.

**B) DISTANCE CORRECTION**

This is the normal drop in LEQ (Db) over these various distances. This is without any effect from surroundings.

**C) TRACK EFFECT**

As the source of sound (karts) are traveling around a track, this is the factor for correcting to the average sound from any single spot on the track.

**D) GROUND ATTEN.**

The amount of sound which is absorbed by grass and small trees (less than 6') while traveling over the various distances.

**E) LEQ(Db) FOR INDICATED NUMBER OF KARTS**

The actual sound level at the various locations with various numbers of karts on the track.

## COMMERCIAL TRACK SPECIFICATIONS

**TRACK CONSTRUCTION:** Concrete or asphalt, can be used as your track surface. If asphalt is used, make sure it is a good grade to ensure a smooth surface finish (such as tennis court mix). Asphalt should be a minimum 2" thick. If concrete is used, the finish should be fairly smooth, but not glossy. Surface finish is important, because if the surface is too rough, tires will wear excessively; If surface is too smooth, a little moisture will make karts difficult to control.

**TRACK LENGTH:** Varying with layout design, a typical (average) track should accommodate one kart per 75' of length e.g. 18 karts on 1/4 mile (1320') track.

**TRACK WIDTH:** Should be a minimum of 20' and maximum of 25'. We recommend that the track be 5' wider on turns than on straight-aways. Contact your licensing and inspection office for track width minimums.

**BANKING:** On turns will help reduce tire wears, and will make the ride more interesting. Maximum banking is 1" per foot of track width. Straight-aways must be flat except for 2 degrees allowed for drainage.

**TRACK GRADE:** Recommended 5% maximum.

**GUARDRAIL:** We recommend the use of "Driscopipe" polyethylene guardrail. A 6" diameter size should be used in a double stacked format. The wall size of the pipe, or code is SDR26, which is readily available from Phillips 66 and their distributor. Please review spec sheets on following pages for complete installation instruction and distributor listing. Note: The steel band/tire guardrail system is also compatible with Can-Am karts. It is important, however, to advise the sales department if you will be using this system, to ensure that the wheelguard pipe of the karts will match correctly with the steel band.

**LOADING ZONE:** Should have separate entrance and exit lanes. A marked deceleration lane will improve the safety in operation of your track.

**FENCING:** Height should be 4' minimum. Posts should be 10' on centers. We recommend that fencing be on the inside of posts. Try to use chain link or 2" solid board, or cement block, as long as karts are not in dire contact. Gates should be supervised by an attendant when track is open and locked when track is closed.

## COMMERCIAL TRACK SPECIFICATIONS (cont'd)

- ◆ **SPECTATOR AREA:** Should be separated from the track and pits by a fence. Bleachers or grandstands should be constructed with back and side rails.
- ◆ **PARKING AREAS:** Should be level, graded, clearly identified, and of adequate size.
- ◆ **WIRING:** Should be installed in compliance with the requirements of the appropriate authorities.
- ◆ **FIRE EXTINGUISHERS:** Should be installed in sufficient quantity to provide adequate protection.
- ◆ **MAXIMUM SPEED:** Recommended is 18-24 MPH. A well designed, exciting track doesn't require karts to go any faster.
- ◆ **RIDER HEIGHT REQUIREMENT:** Minimum of 54" is recommended.
- ◆ **SAFETY SIGNS:** Should be displayed prominently at various locations. We will supply you with our suggestions for signs, if you wish.
- ◆ **SUPERVISORY STAFF:** Must be cordial, neat in appearance, and well-versed in safety regulations. At least one person should be trained in first-aid treatment.
- ◆ **RULES:** Should be verbally instructed to each group of riders before boarding karts and displayed prominently where riders may read them.

## DRIVE BELT MAINTENANCE

### LEOPARD AND JAGUAR

**TO DISASSEMBLE:** (See Figure 5.2)

1. Remove drive side wheel.
2. Loosen engine and push forward on motor mount (engine removal not necessary).
3. Remove two (2) bolts holding motor mount to frame. **\*\*CAUTION** is needed because engine will tilt back on frame several inches.
4. Remove caliper (brake line disconnection is not necessary)
5. Slide brake disc away from caliper mount.
6. Remove two (2) 1/2" bolts from outside pillow block on drive side axle.
7. Tilting of axle, motor mount and engine is now possible to slide new belt under pillow block.

**TO RE-ASSEMBLE:**

Reverse disassembly instructions.

- \*\*** Be sure, when tightening outside pillow block, that brake disc is aligned with brake pad on caliper mount.
- \*\*** Be sure, when tightening engine that engine is square to motor mount and belt is tight.
- \*\*** Loosen axle gear locking bolts and realign axle gear with engine drive gear and re-tighten.

## DRIVE BELT MAINTENANCE (cont'd)

### RENTALS

#### **DISASSEMBLY:** (See Figure 5.1)

1. Lay board across frame (large enough to hold engine).
2. Unbolt engine and set on board (throttle disconnect not necessary).
3. Remove motor mount and set aside.
4. Remove caliper (brake line disconnect not necessary).
5. Remove two (2) 1/2" bolts holding inside pillow block on drive side axle.
6. Tilting of the axle is now possible to remove old belt if necessary and install new belt.

#### **RE-ASSEMBLY**

Reverse Disassembly instructions.

- \*\* Make sure, when tightening inside pillow block, that axle is properly aligned with floating side axle.
- \*\* Make sure, when tightening engine, that engine is square to motor mount and belt is tight.
- \*\* Loosen veri-hub locking bolts (axle gear) and realign with top gear.

# GENERAL SPECIFICATIONS

## DRIVE SYSTEM

Belt driven  
5.5hp -6.5hp Honda engine  
9.0 hp Honda engine

## HEADREST & FACEPADS

Water Blown integral-Skinned poly Foam  
2" thick on Headrest  
6" thick on Facepad

## AXLES & BEARINGS

Precision Ground Supreme Shaft 15" to 34"  
1 1/4" Pillow Block bearing unit

## ROLLBARS

1 1/2" x .125 wall cold rolled electric weld  
tubing (Chromed)

## BODIES

Cross-linked High Density Polyethylene

## SEATBELTS

Lap & Shoulder Harness

## STEERING

Grant 10" and 12" Steering Wheels  
5/8" Steering shaft  
cold rolled (SAE C1018)

## WHEEL GUARDS & BUMPERS

UHMW 3/4" or 5/8" x 4" Formed  
4" or 6" Docking Rubber  
Cross-linked Polyethylene

## FASTENERS

All Nuts & Bolts are GRADE 8 or better

## BRAKING SYSTEM

Dual Hydraulic brakes

## WELDS

All welds are 1/4" Fillet welds using .035 wire  
with Tri-Mix Shielding Gas

## TIRES & RIMS

All rims are 1 or 2pc Steel  
Tires are 4ply slick or recap

## FRAME SPECIFICATIONS

1" X 1" X .125 Wall Steel Tube HSS (50W)  
1.5" X 1.5" X .125 Wall Steel Tube HSS (50W)  
3/16" Steel plate (Formed) A53/A120  
1 1/4" SCM 80 Pip  
2" X 2" X 1/4" Ankle Steel HSS (50W)  
C5 X 6.5" Channel Steel (44W)

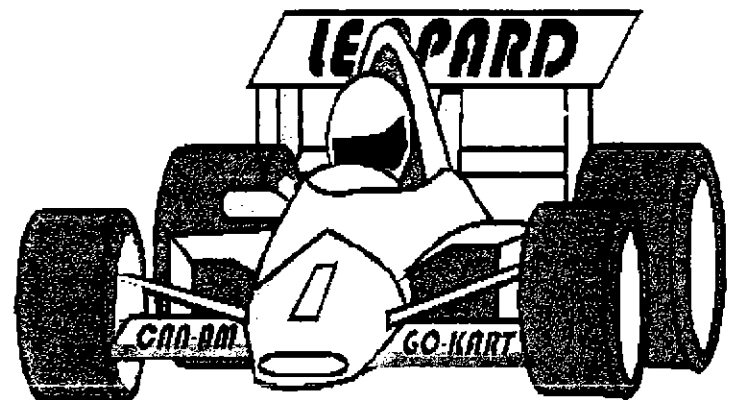

# DRIVE BELT ASSEMBLY

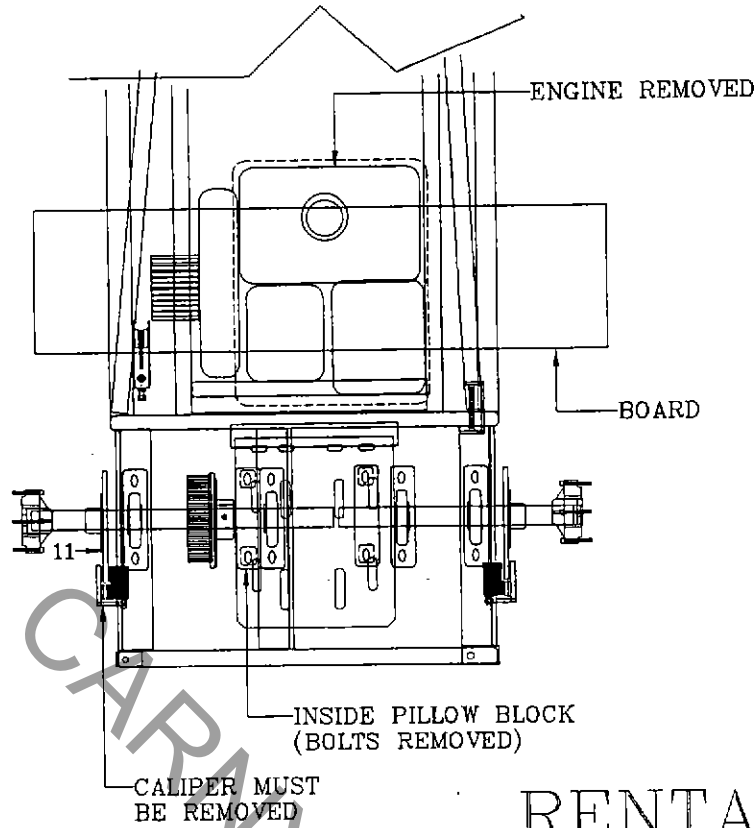
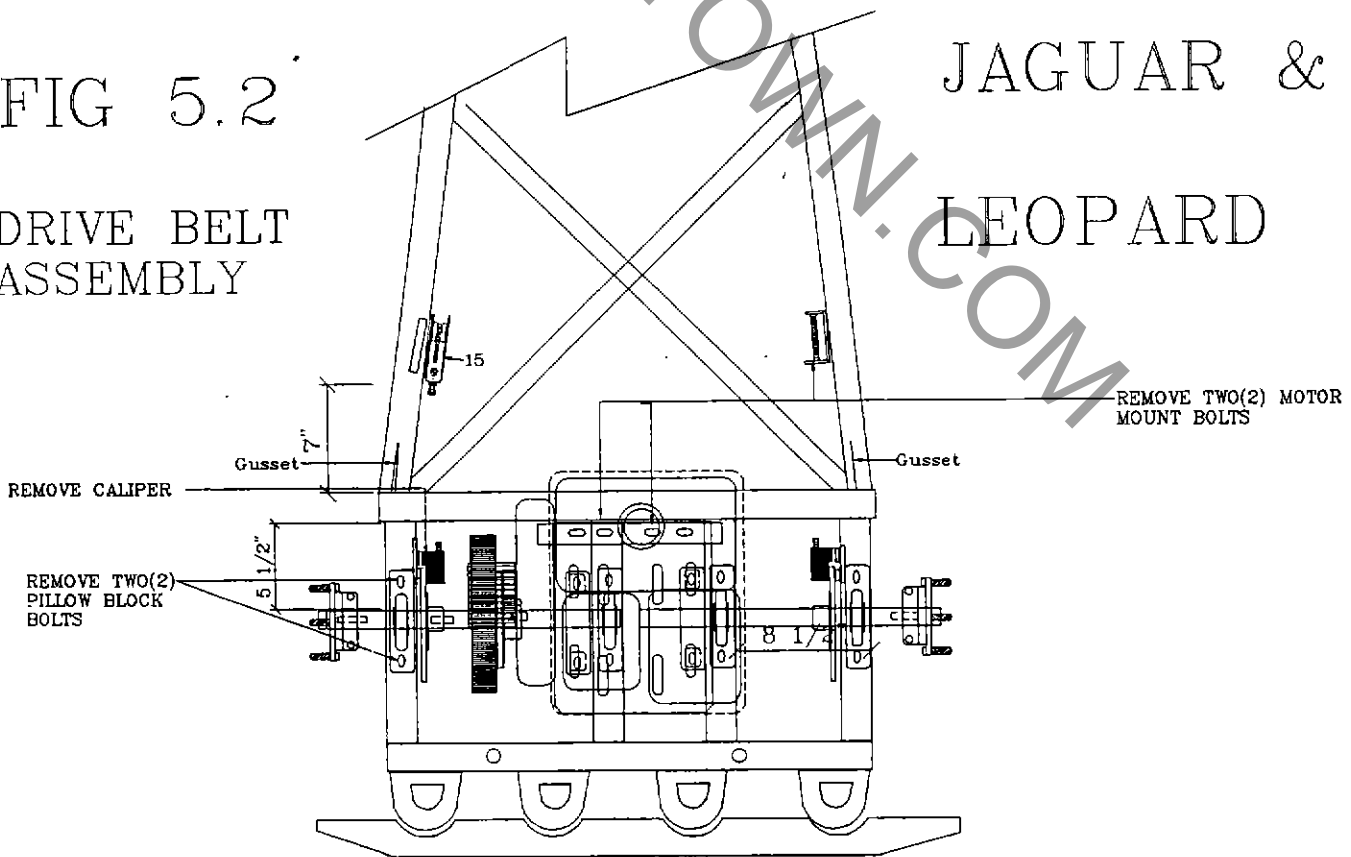

FIG 5.1

RENTALS

FIG 5.2

# DRIVE BELT ASSEMBLY



JAGUAR &

LEOPARD

# RENTALS

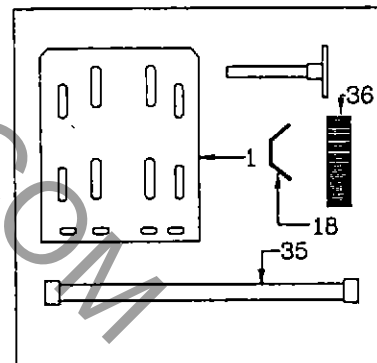
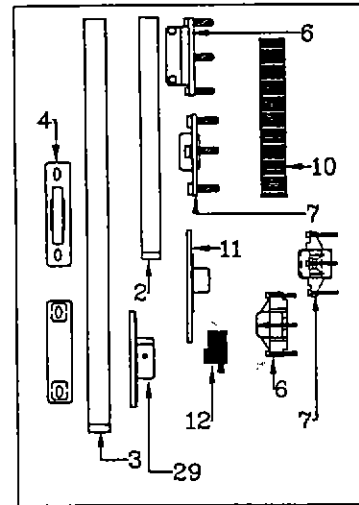
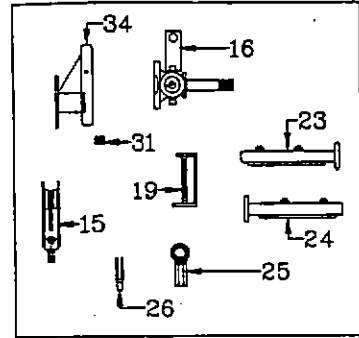
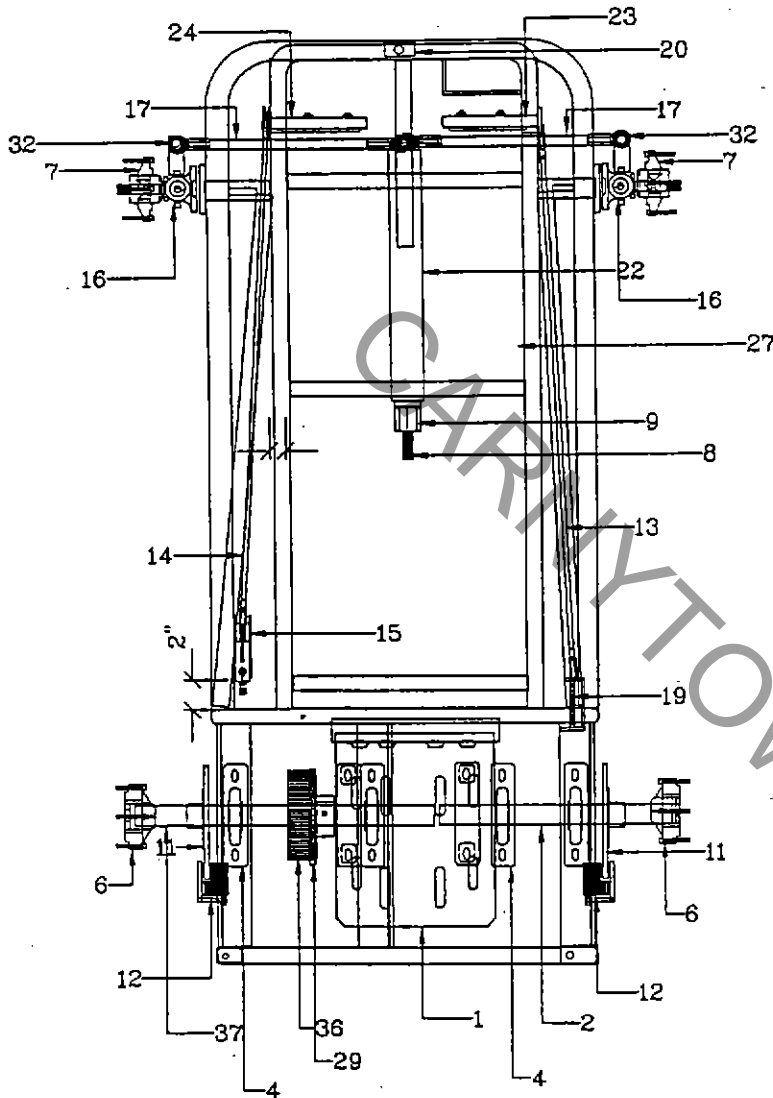

- (1) MOTOR MOUNT
- (2) 15" AXLE
- (3) 26" AXLE
- (4) PILLOW BLOCK
- (6) REAR HUB (RENTAL)
- (7) FRONT HUB (RENTAL)
- (8) STEERING SHAFT
- (9) STEERING SHAFT NUT
- (10) 100 TOOTH GEAR
- (11) BRAKE DISK
- (12) BRAKE CALPER
- (13) GAS ROD
- (14) BRAKE ROD
- (15) MASTER CYLINDER
- (16) FRONT SPINDLE
- (17) TIE ROD (1/2")
- (18) SUSPENSION TOWER
- (19) GAS RETURN SPRING
- (20) FRONT BODY MOUNT TABS

- (21) REAR BODY TABS
- (22) STEERING COLUMN
- (23) GAS PEDAL & GAS PEDAL MOUNT
- (24) BRAKE PEDAL & PEDAL MOUNT
- (25) TIE ROD END
- (28) CLEVIS & PIN
- (27) FLOOR PAN
- (28) LPD NOSE MOUNT
- (29) VERI HUB
- (30) KEY WAY
- (31) SUSPENSION SPRING
- (32) TIE ROD END
- (33) BODY MOUNT TABS
- (34) LPD SUSPENSION ARM
- (35) LPD SUSPENSION MOUNT
- (36) 64 TOOTH SPROCKET
- (37) 19" AXLE

# LEOPARD

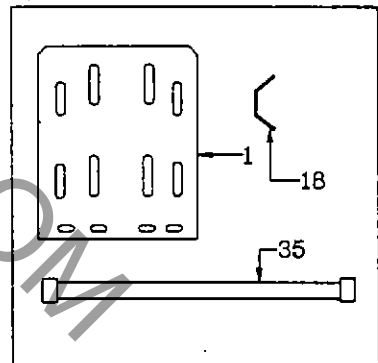
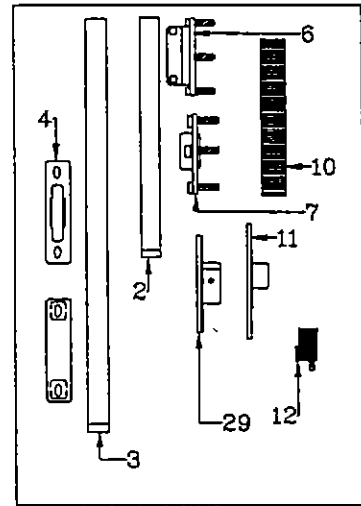
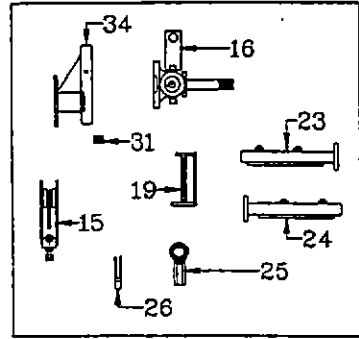
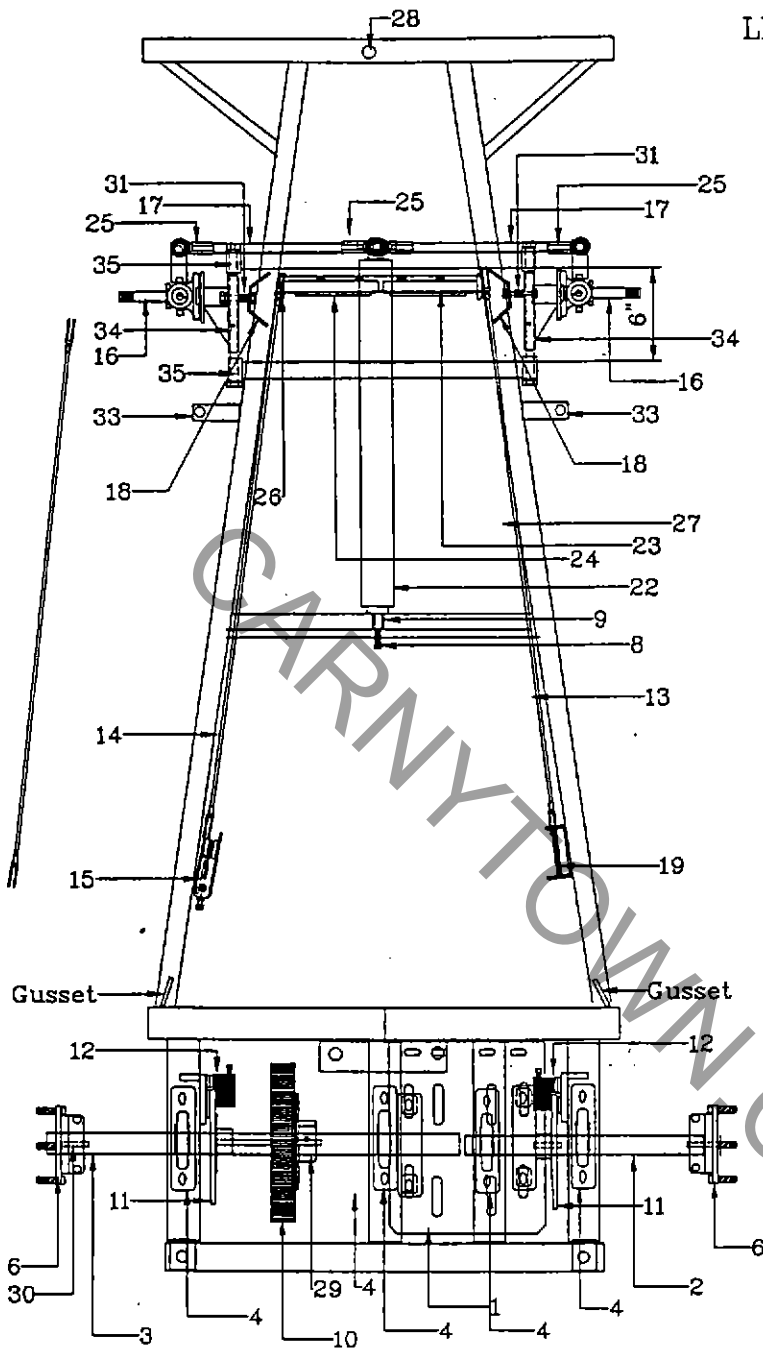

- (1) MOTOR MOUNT
- (2) 15" AXLE
- (3) 26" AXLE
- (4) PILLOW BLOCK
- (6) REAR HUB (1 1/4")
- (7) FRONT HUB
- (8) STEERING SHAFT
- (9) STEERING SHAFT NUT
- (10) 100 TOOTH GEAR
- (11) BRAKE DISK
- (12) BRAKE CALPER
- (13) GAS ROD
- (14) BRAKE ROD
- (15) MASTER CYLINDER
- (16) FRONT SPINDLE
- (17) TIE ROD (1/2")
- (18) SUSPENSION TOWER
- (19) GAS RETURN SPRING
- (20) FRONT BODY MOUNT TABS

- (21) REAR BODY TABS
- (22) STEERING COLUMN
- (23) GAS PEDAL & GAS PEDAL MOUNT
- (24) BRAKE PEDAL & PEDAL MOUNT
- (25) TIE ROD END
- (26) CLEVIS & PIN
- (27) FLOOR PAN
- (28) LPD NOSE MOUNT
- (29) VERI HUB
- (30) KEY WAY
- (31) SUSPENSION SPRING
- (32) TIE ROD END
- (33) BODY MOUNT TABS
- (34) LPD SUSPENSION ARM
- (35) LPD SUSPENSION MOUNT

# CHEETAH

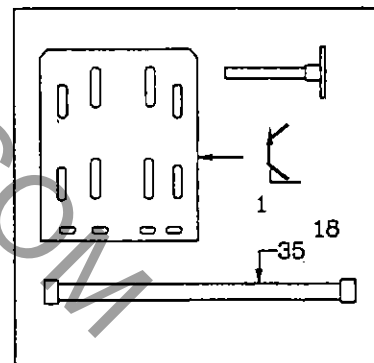
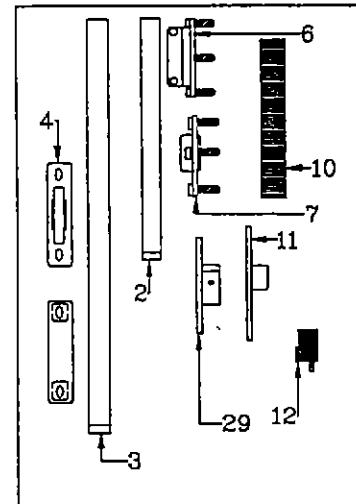
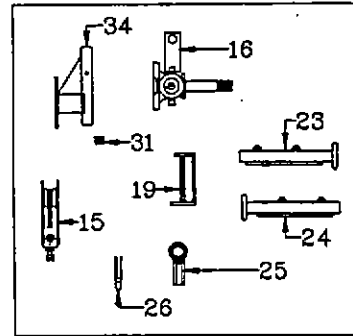
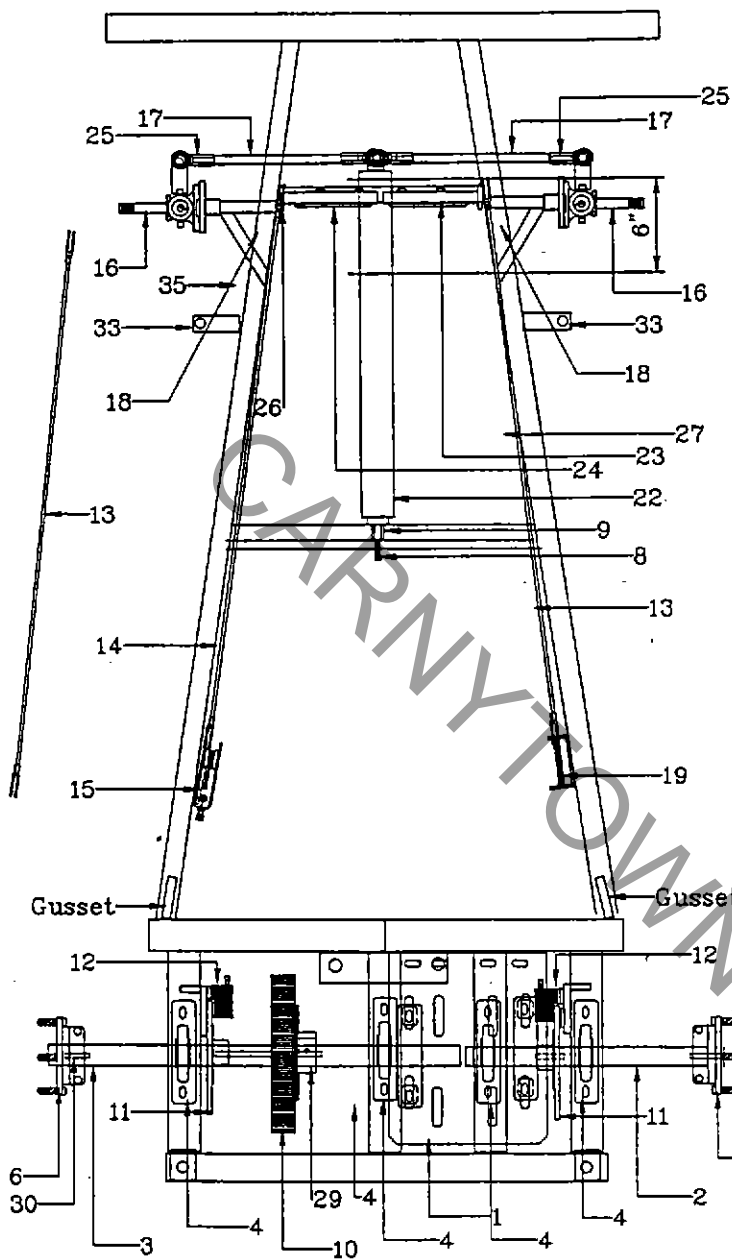

- (1) MOTOR MOUNT
- (2) 15" AXLE
- (3) 26" AXLE
- (4) PILLOW BLOCK
- (6) REAR HUB (1 1/4")
- (7) FRONT HUB
- (8) STEERING SHAFT
- (9) STEERING SHAFT NUT
- (10) 100 TOOTH GEAR
- (11) BRAKE DISK
- (12) BRAKE CALPER
- (13) GAS ROD
- (14) BRAKE ROD
- (15) MASTER CYLINDER
- (16) FRONT SPINDLE
- (17) TIE ROD (1/2")
- (18) SUSPENSION TOWER
- (19) GAS RETURN SPRING
- (20) FRONT BODY MOUNT TABS

- (21) REAR BODY TABS
- (22) STEERING COLUMN
- (23) GAS PEDAL & GAS PEDAL MOUNT
- (24) BRAKE PEDAL & PEDAL MOUNT
- (25) TIE ROD END
- (26) CLEVIS & PIN
- (27) FLOOR PAN
- (28) LPD NOSE MOUNT
- (29) VERI HUB
- (30) KEY WAY
- (31) SUSPENSION SPRING
- (32) TIE ROD END
- (33) BODY MOUNT TABS
- (34) LPD SUSPENSION ARM
- (35) LPD SUSPENSION MOUNT

# JAGUAR

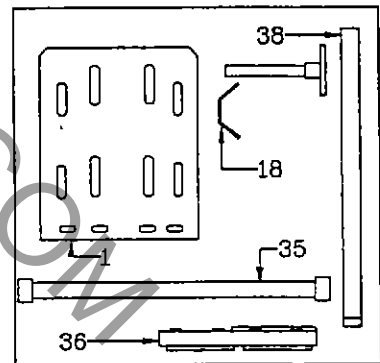
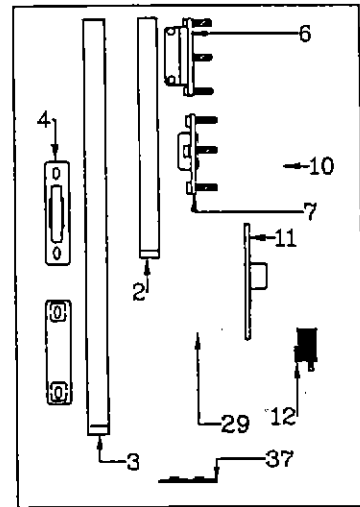
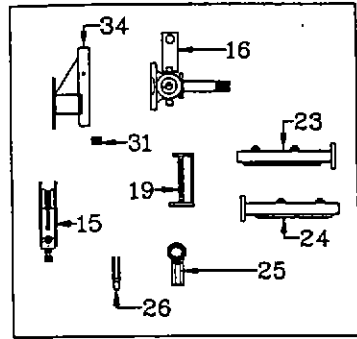
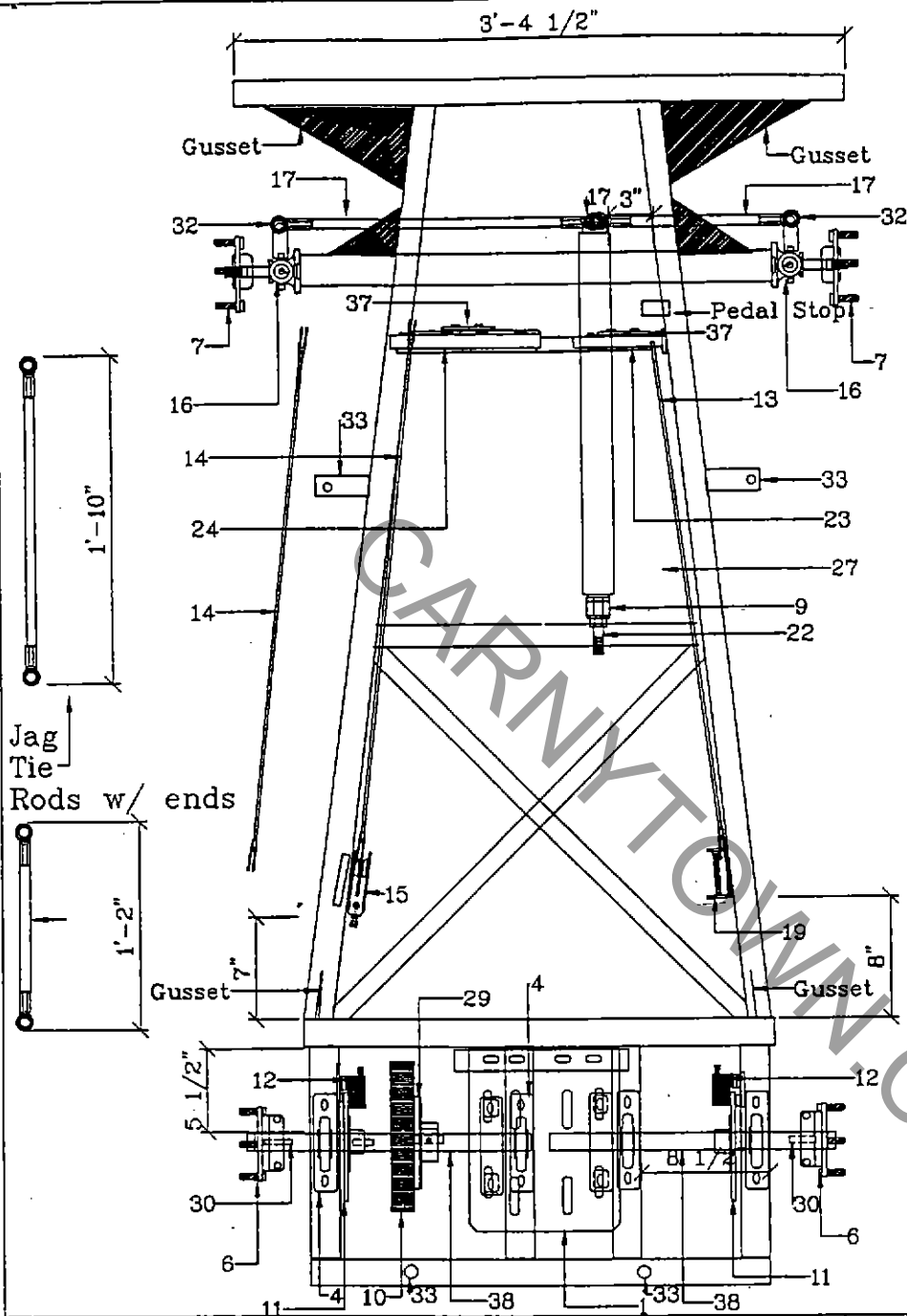

- (1) MOTOR MOUNT
- (2) 15" AXLE
- (3) 26" AXLE
- (4) PILLOW BLOCK
- (6) REAR HUB (1 1/4")
- (7) FRONT HUB
- (8) STEERING SHAFT
- (9) STEERING SHAFT NUT
- (10) 100 TOOTH GEAR
- (11) BRAKE DISK
- (12) BRAKE CALPER
- (13) GAS ROD
- (14) BRAKE ROD
- (15) MASTER CYLINDER
- (16) FRONT SPINDLE
- (17) TIE ROD (1/2")
- (18) SUSPENSION TOWER
- (19) GAS RETURN SPRING
- (20) FRONT BODY MOUNT TABS

- (21) REAR BODY TABS
- (22) STEERING COLUMN
- (23) GAS PEDAL & GAS PEDAL MOUNT
- (24) BRAKE PEDAL & PEDAL MOUNT
- (25) TIE ROD END
- (26) CLEVIS & PIN
- (27) FLOOR PAN
- (28) LPD NOSE MOUNT
- (29) VERI HUB
- (30) KEY WAY
- (31) SUSPENSION SPRING
- (32) TIE ROD END
- (33) BODY MOUNT TABS
- (34) LPD SUSPENSION ARM
- (35) LPD SUSPENSION MOUNT
- (36) JAG BRAKE PEDAL
- (37) PEDAL MOUNT BRACKET
- (38) 19" AXLE (JAGUAR)

# LYNX

## MODEL #88

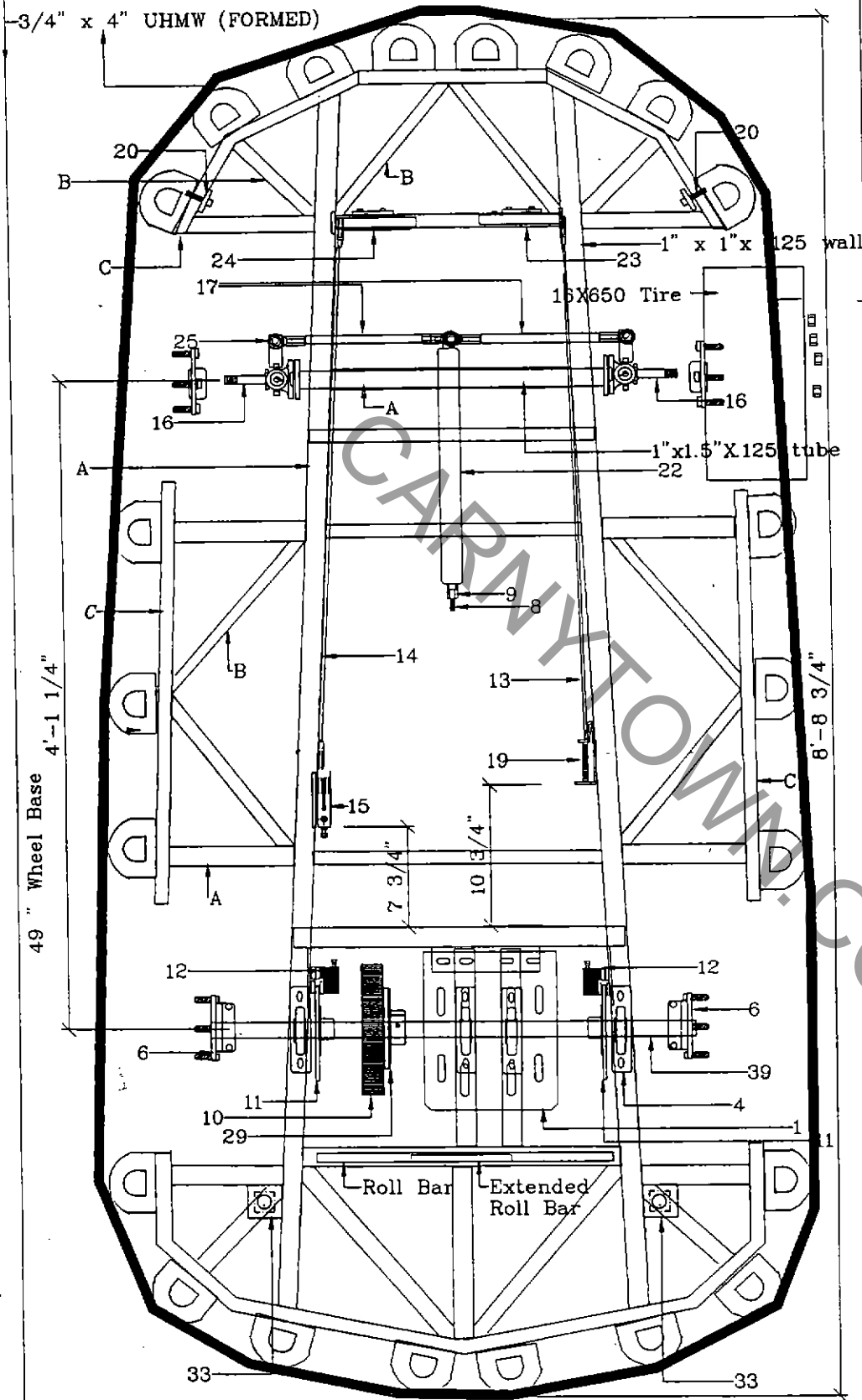

- (1) MOTOR MOUNT
  - (2) 15" AXLE
  - (3) 26" AXLE
  - (4) PILLOW BLOCK
  - (6) REAR HUB (1 1/4")
  - (7) FRONT HUB
  - (8) STEERING SHAFT
  - (9) STEERING SHAFT NUT
  - (10) 100 TOOTH GEAR
  - (11) BRAKE DISK
  - (12) BRAKE CALPER
  - (13) GAS ROD
  - (14) BRAKE ROD
  - (15) MASTER CYLINDER
  - (16) FRONT SPINDLE
  - (17) TIE ROD (1/2")
  - (18) SUSPENSION TOWER
  - (19) GAS RETURN SPRING
  - (20) FRONT BODY MOUNT TABS
  - (21) REAR BODY TABS
  - (22) STEERING COLUMN
  - (23) GAS PEDAL & GAS PEDAL MOUNT
  - (24) BRAKE PEDAL & PEDAL MOUNT
  - (25) TIE ROD END
  - (26) CLEVIS & PIN
  - (27) FLOOR PAN
  - (28) LPD NOSE MOUNT
  - (29) VERI HUB
  - (30) KEY WAY
  - (31) SUSPENSION SPRING
  - (32) TIE ROD END
  - (33) BODY MOUNT TABS
  - (34) LPD SUSPENSION ARM
  - (35) LPD SUSPENSION MOUNT
  - (36) JAG BRAKE PEDAL
  - (37) PEDAL MOUNT BRACKET
  - (38) 19" AXLE (JAGUAR)
  - (39) 36" AXLE
  - (40) 4" D STOCK
- A ) 1" x 1.5" x .125 WALL TUBE  
 B ) 1" x 1" x .125 WALL TUBE  
 C ) 3/16" FORMED CHANNEL

\*\*\*\* ALL BOLTS & NUTS ARE  
 \*\*\*\* GRADE 8 OR BETTER

MODEL NAME: Naskart  
 DATE: May 30th/94

SCALE 1' = 14"

**DO NOT USE AUTOMOTIVE BRAKE FLUID!**

Hydraulic brakes periodically may require bleeding (removal of air from system).

To do so simply remove master cylinder fill cap (Fig. 3:2 #2) loosen bleeder valve on caliper (Fig. 3:3 #4) and with puc hose (2 feet) over end of bleeder screw, draw brake fluid through system using mouth\* and clean fuel line. Take caution not to empty master cylinder of hydraulic fluid.

\*NOTE: Take caution not to bring fluid into mouth, a vacuum pump may also be used.

This operation may require 2 people, i.e.: one to add fluid to master cylinder and one is drawing fluid from caliper. When air bubbles stop coming from bleeder valve, tighten valve before drawing from the puc hose. Systems which are equipped with two caliper assemblies (Fig 1:1) "A" caliper must be bled before "B" caliper.

**DO NOT USE AUTOMOTIVE BRAKE FLUID!**

FIG 1:1

HYDRAULIC BRAKE SYSTEM

- 1. BRAKE PEDAL PLATE
- 2. BRAKE PEDAL
- 3. BRAKE ROD
- 4. MASTER CYLINDER
- 5. BRAKE LINE
- 6. BRAKE DISC.
- 7. AXLE
- 8. BRAKE CALIPER HALF

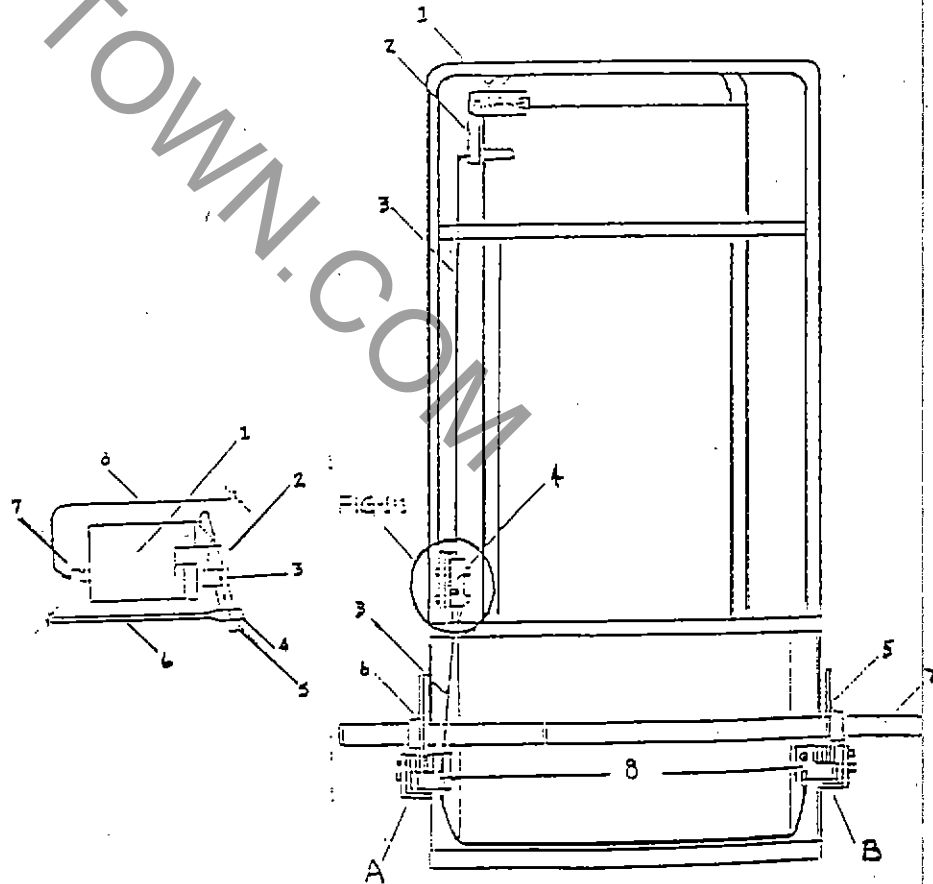

FIG 1:1

- 1. CYLINDER BODY
- 2. ACTUATING ARM
- 3. ACTUATING PIN
- 4. BRAKE CLEVIS
- 5. CLEVIS PIN
- 6. BRAKE ROD
- 7. COMP. CABLE FITTING
- 8. BRAKE LINE

**DO NOT USE AUTOMOTIVE BRAKE FLUID!!**