

MFB. BERTAZZON.3B
S.R.L.
Ride: Himalaya/Music Fest

Musik Fest

(Super Himalaya)

CARNYK
OWN.COM

Bertazzon

FRONT LEVELLING JACKS OF TRAILER OPERATION INSTRUCTIONS

- 1) - OPEN THE COCK HANDLES <A> OF EACH FRONT JACKS;
- 2) - TIGHTEN THE PRESSURE SCREW OF THE PUMP <E>;
- 3) - INSERT THE PUMP HANDLE INTO THE PROPER HOUSING AND LOCK IT WITH APPOSITE SREW;
- 4) - PLACE THE BEARING PLATES UNDER THE JACKS POSITION;

HOISTING THE TRAILER:

- 1) - PULL THE CONTROL LEVERS <C> AND <D> OF THE FRONT PISTONS ;
- 2) - MOVE THE PUMP HANDLE <F> UP AND DOWN ;
- IN ORDERTO MODIFY THE LEVEL OF THE TRAILER, PLEASE MOVE THE BOTH CONTROL LEVERS <C> AND <D> TO THE CENTRAL POSITION AND OPERATE THE LEVER CORRSPONDING TO THE JACK YOU WANT TO MOVE;
- 3) - SET BOTH CONTROL LEVERS <C> AND <D> TO THE CENTRAL POSITION;
- 4) - **CLOSE BOTH COCK HANDLES <A> WHEN LEAVING THE TRAILER STANDING ON FRONT JACKS (PARKING).**

LOWERING THE TRAILER:

CAUTION ! : - IN ORDER TO PROCEED FOR THE LOWERING PROCEDURE, PLEASE OPERATE ONLY ONE JACK AT A TIME AND LET IT RIDE FOR NO MORE THEN 10 CM (4').

- 1) - PUSH THE CONTROL LEVER <C> OR <D> OF THE FRONT PISTONS;
- 2) - MOVE UP AND DOWN THE PUNP LEVER <F>;

CAUTION ! : - PLEASE CONSIDER BOTH JACKS NORMALLY MOVES FOR 5-10 CM. (2'-4') AFTER STOPPING PUMPING.
- IN ORDER TO STOP THE JACK MOTION PLEASE SET THE CONTROL LEVER ON CENTRAL POSITION.

- 3) CLOSE THE COCK HANDLES <A> OF THE PISTONS.

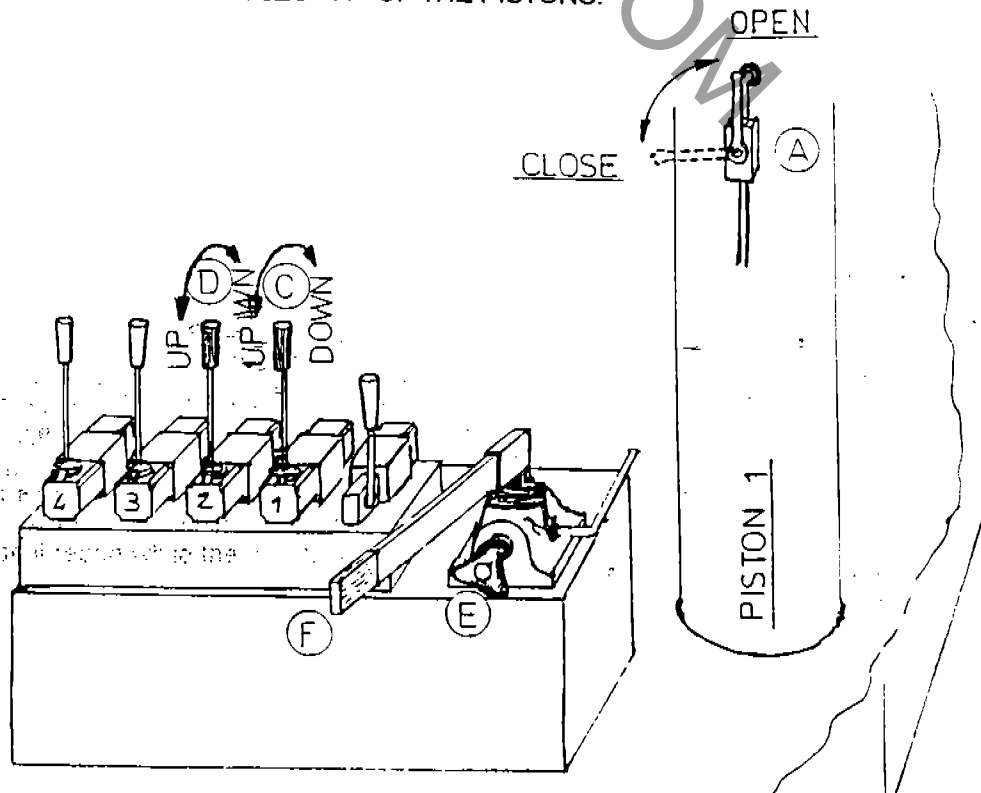

PARKING THE SEMITRAILER

A) HAND BRAKE LEVER

The hand brake lever is located inside the lower body on the right side of trailer, just in front of the front wheel.

B) AIR BRAKE RELEASE VALVE

The air brake control button is placed in front of the big case of the trailer, on the right side.

C) HYDRAULIC PUMP FOR JACKS

The hydraulic pump is located inside the lower body on the front right side of the semitrailer.

D) AIR SPRINGS CONTROL VALVE

The air springs control lever is located just behind the rear wheel on the right side of semitrailer.

E) ANCHOR CLAMPS

There have been arranged four anchor clamps on front and rear side of trailer, to be used for securing it during sea transport.

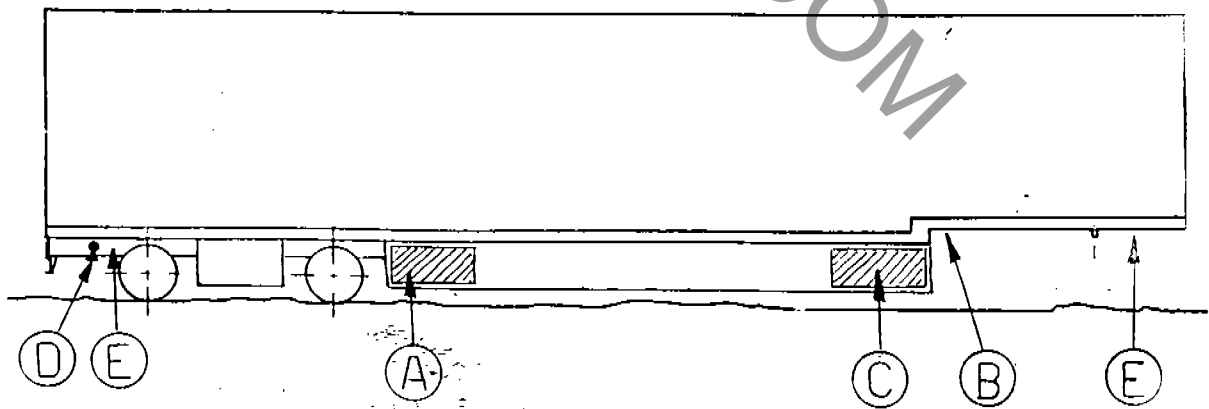

A)



ZORZI

Officine ZORZI S.p.A.

...dal 1918 i veicoli che si distinguono

Capitale Sociale L. 1.300.000.000 int. vers.

31100 TREVISO - Via Seitz 4 - C.P. 148 - ☎ (0422) 57237 - 5 linee r.a. - Telefax (0422) 547927 - Telex n. 410630
Reg. Soc. Trib. TV 14903 - C.C.I.A.A. Treviso 40559 - POS. EXPORT 880216 - P. IVA 01239580267 - C. F. 00186030014

Treviso, il _____

Ns. rif. _____

OGGETTO _____

SEMITRAILER - TECHNICAL DESCRIPTION

Brand: ZORZI

Type: 30S150/19P

Kind: SEMITRAILER

Total weight: 30 ton.

Name and adress of the manufacturer: ZORZI s.p.a. via POSTUMIA,23 31100 -T.

I - GENERAL FEATURES OF THE VEHICLE

N° of the axles: 2

N° of the wheels: 4

Axles type: BPW KHZ FD 10010-15

Tyres size: 245/70 R19,5

The semitrailer is built with a carryng structure with a plate on the fron part in which is fitted the king pin; on the rear part there are the suspensions.

The carryng structure is made as it follows:

A frame built-up with two longitudinal members made in pressed steel profile, or in bented steel plate, or in steel structure electro welded.

The profile have "I" section.

The two longitudinal members are connected with cross members build-up in the same way as above.

The carryng structure is assembled with electrowelding.

II - DIMENSIONS AND WEIGHTS

Wheelbase (distance between king pin and ax of tandem):	11,385 m
Distance between two axles cosecutive:	2,49 m
Tread:	1,880 m
Lenght of the frame (without body):	15,2 m
Width of the frame (without body):	2,42 m
Front overhang (without body):	1,2 m
Rear overhang (without body):	1,37 m
Over all lenght (with body):	==== m
Over all width (with body):	==== m
Front overhang (with body):	==== m
Rear hoverhang (with body):	==== m
Height from ground (min.):	0,160 m
Tara weight:	4000 Kg
Dead weight on the king pin:	960 Kg
Dead weight on the axles:	3040 Kg
Total weight:	30000 Kg
Total weight on the king pin:	12350 Kg
Total weight on the axles:	17650 Kg

III - SUSPENSION

The suspensbn system is made with parabolic springs and air balls

IV - STEERAGE

The steerage is guaranted by the king pin.

V - BRAKING

Braking system at compressed air, direct and automatic; In case of brakedows of coupling is assured the braking by an emmergency relais valve. Each wheel has a drum and the brake is able to work both in front and in rear running.

When the driver sets on the brake pedal of the tractor will work both the brakes of the tractor and the brakes of the semitrailer.

The brake circuit fulfils at the EEC regulations 85/647 and 88/194.

MAIN DEVICES

The brake device is the type drum and expansion shoe with a "S" came set-up by a lever.

The control of the brake system is on all the axles. For each axle there is two cylinders that operate against the levers of the brake camshaft.

Utilizing pressure: 7,5 bar

Air bottle capacity: 75 lt

Air main made in plastic tubes with diameter mm 8 or mm 12.

BRAKES FEATURES

Drum made in special steel nickel-chrome cast iron, fixed at the hub of the wheel with two brake-shoes expandible with a came.

GENERAL FEATURES

Model of brake: BPW SN 3620

Diameter of the drum: mm 360

Width of the brake shoes: mm 200

Lenght of the levers: mm 150

Diameter of the cylinder: 13,46 (VASE 24")

Brake : verbal N°: TDB 0205

Brake capacity: Kg 11550

Tyres set up: 245/70 R19.5

Park brake, lenght of the lever: mm 200

On the brake control circuit is fitted a braking calibrator that automatically increase or decrease the braking pression as a function of the weight on axles.

PARKING BRAKE

It is made by a hand lever that transmits, throught a steel rope, the stress to the levers of the brake camshaft.

AUTOMATING BRAKING IN CASE OF BROKEDOWN OF COUPLING

It is assured by the air distributor valve that let operate a relè emmergency valve.

VI - BODY

The semitrailer (model: 30 S 150/19P) has left our factory with the following body:

In case the vehicle would be fitted with a different body, in the future, the manufacturer of the body will have to submit a certificate in three copies in which he declares that the frame has not been modified and that it is conforme at the type described.

VII - LIGHTS AND SIGNALS

All the devices fulfil at the regulations in force.

VIII - SUNDRIES

All our vehicles are fitted with:

- N° 1 rear bumper that fulfils at ECC regulation 79/490 and 81/333.
- N° 1 plate of the manufacturer
- N° 1 plate of the calibrator.

The numeration of the model serie starts with the n°: 0158

CONFORMITY CERTIFICATE

Mr. Franco Zorzi, Chairman of the ZORZI s.p.a. - 31100 TREVISO -
Italy - manufacturer; hereby certify:

A) That the vehicle:

- 1 - Kind: Semitrailer
- 2 - Brand: ZORZI
- 3 - TYPE: 30 S 150/19P - Version: framed with cross members and side rails
- 4 - Chassis Number: ZAX30S15019000158
- 5 - Body type: framed with cross members and side rails
- 6 - Dimensions: .Width : mm 2420
.Length : mm 15200
.Surface: mtq 36.8
- 7 - Total weight: Kg 30000
- 8 - Tara weight : Kg 4000
- 9 - Pay load admitted: Kg 26000

Is fully comply with the description as above.

B) That this vehicle has left our factory on dateto be delivered to:

.....

Treviso date: 24/08/93

INDEX

INDEX.....	2	3.3. Manual Operation.....	22
INTRODUCTION.....	3	3.4. Automatic Operation.....	22
1. DESCRIPTION.....	4	3.5. Loading and Unloading Procedure.....	23
2. INSTALLATION.....	5	3.6. Emergency.....	24
2.1. Hydraulic Circuit.....	5	3.7. Power Blackout.....	25
2.1.1. hydraulic gearcase.....	6	3.8. Lighting.....	25
2.1.2. electric pump.....	7	4. SERVICE.....	26
2.1.3. manual pump.....	7	4.1. Central Rotor.....	26
2.1.4. leveling jacks.....	7	4.1.1. fifth wheel.....	26
2.1.5. axle cylinders.....	7	4.1.2. electric contacts.....	26
2.1.6. first stage column cylinders.....	7	4.1.3. pneumatic rotating joint.....	26
2.1.7. roof cylinders.....	8	4.2. Rotating Structure.....	27
2.1.8. adjustments.....	9	4.2.1. arms.....	27
2.2. Setting-Up.....	9	4.2.2. cars.....	27
2.2.1. the trailer.....	9	4.3. Hydraulic Circuit.....	27
2.2.2. the roof.....	10	4.4. Pneumatic Circuit.....	26
2.2.3. the base.....	13	4.5. Stationary Structure.....	29
2.2.4. rotating arms.....	15	4.6. Periodic Check-List.....	29
2.2.5. cars.....	16	4.7. Periodic Lubrication.....	31
2.2.6. miscellaneous.....	17	5. WARNINGS.....	33
2.2.7. useful electric controls.....	17	6. TECHNICAL DATA.....	34
2.3. Disassembly Procedure.....	18	6.1. General Features.....	34
2.4. Transportation.....	19	6.2. Operational Limitations.....	34
2.5. Electric Connect. and First Starting.....	19	6.3. Electrical Power Requirement.....	35
3. OPERATION OF THE RIDE.....	20	6.4. Principal Operational Dimensions.....	35
3.1. The Control Panel.....	20	7. ADDITIONAL INFORMATION.....	36
3.2. Ignition.....	21		

INTRODUCTION

This manual describes the procedures of installation, operation and maintenance of the ride "SUPER HIMALAYA SR-T2".

It is addressed to skilled and qualified persons with full knowledge of the methods of intervention according to the different cases.

When the word:

⚠ CAUTION: *comes out, it means that special procedures shall be carried out in order to avoid damages to things and persons.*

References to illustrations consist of the number of the picture and the number of the point inside the picture, i.e. (3/14) means picture No 3 Point No 14.

The use of original spare parts is a guarantee for the good working condition and the long life of your equipment.

1. DESCRIPTION

Dimensions of the ride plan: 18,0 m x 17,4 m.

The ride consists of a rail with circular development and three dunes. Twenty cars run along the rail. These cars are connected to the central rotor by the same number of arms in reinforced steel round pipe.

The rail is supported by a horse structure in galvanized steel square section. The footboards approaching the cars are in aluminium treadplate supported by a steel framework structure connecting the horses which are also connected to the central body through tie rods and longerons in tubular square section.

The central body of the ride is composed of the semitrailer. All equipment of the hydraulic, pneumatic and electric circuit is located here. During the setting-up, the semitrailer is laid on the ground through reticular frames in tubular steel placed all around its perimeter.

The ride is provided with an hydraulic circuit for the assembly and disassembly procedures.

The ride is covered by a reticular metallic structure in galvanized tubular steel supported by two load-bearing columns and by perimeter struts in structural tubular steel.

The supporting structures are covered by ornamental and decorative panels coated with aluminium sheet on which most of the lighting is fixed.

Canvas is in fireproof material and panelling of the cars is in polyester resin.

The cars move by means of 5 selfbraking electric motors which are fixed on the ends of the radial arms.

The electric system is provided with an emergency push button acting on the braking system and the lighting of the cars has a voltage of 24 V DC.

The ride is fed by a three-phase current. The voltage however changes according to the delivery country (see chap.6.3 "Power Requirements").

2. INSTALLATION

The ride must be set up in accordance with the following instructions and with the numeration order of the different parts in order to guarantee its good operation.

Consider that some parts are not numbered because they are equal to one another and therefore interchangeable. However you shall place first all numbered parts in the proper position and then go on with the ones without numeration.

Take note that the numeration is anticlockwise and the space between two numbers refers to the lower number (i.e. the space between the long bar no 1 and the long bar no 2 belong to the long bar no. 1) and that each pin or pivot shall be secured with the proper split pins.

2.1. HYDRAULIC CIRCUIT

The ride is equipped with an hydraulic circuit which is designed to make the assembly and disassembly procedures easier. Its main components, together with the manual controls, are installed permanently inside the trailer lower body, on the front - right side.

This circuit can work also through a manual pump which is indispensable to the parking operations of the semitrailer when no power is present. The semitrailer doesn't have the front ratchet jacks which are normally used as a support for its front ends when it is not hooked at the tractor. For such operation you shall use the leveling front hydraulic jacks which are hydraulically operated.

2.1.1. hydraulic gearcase

The picture below refers to the hydraulic gearcase explaining the functions of the different controls..

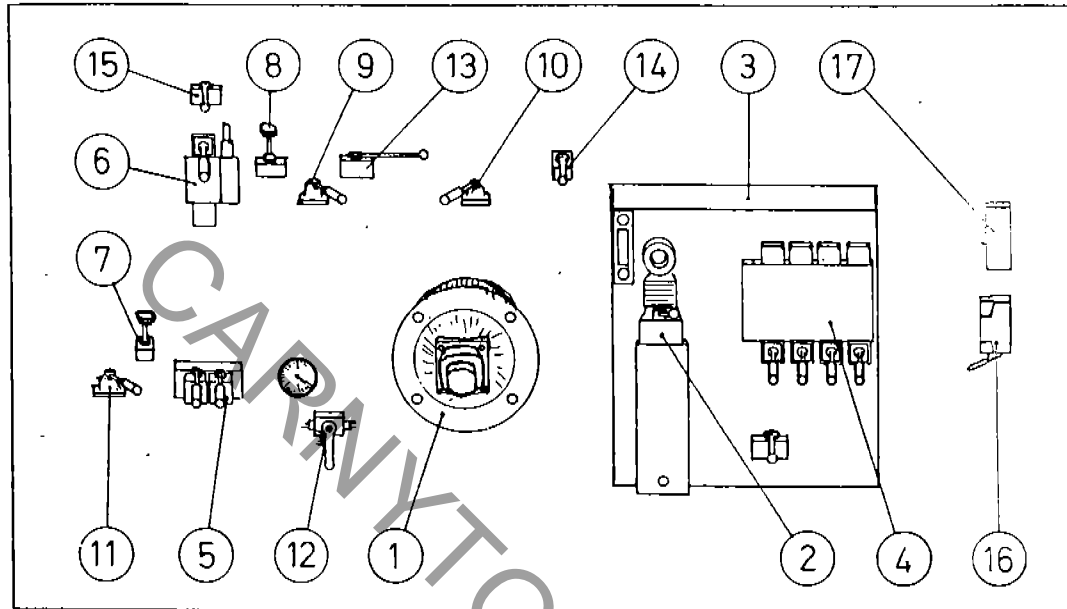

- | | | |
|-----------------------------|------------------------|----------------------|
| 1) ELECTRIC PUMP | 7) MAX. PRESSURE VALVE | 12) VALVE |
| 2) MANUAL PUMP | 8) MAX. PRESSURE VALVE | 13) VALVE |
| 3) OIL TANK | 9) SELECTOR | 14) VALVE |
| 4) TRAILER'S LEVELING PIST. | 10) SELECTOR | 15) VALVE |
| 5) AXLES PINS CYLINDERS | 11) SELECTOR | 16) REVERSING SWITCH |
| 6) 1° COLUMN STAGE CYLINDER | | 17) OVERLOAD CUTOUT |

PICT. 5

2.1.2. electric pump

The electric pump is started by acting on the proper switch on the main panel. At first starting after the electric connection, please check the rotating direction of the pump and verify that the electric motor's fan connected to it turns counterclockwise. If it turns in the opposite direction, you shall reverse the polarities by acting on the proper reverser (1/16), once the pump is disconnected. When the pump is working, after having positioned the proper selector valves correctly, you only need to act on the distributors or on the remote control in order to operate the relative cylinders.

2.1.3. manual pump

The manual pump has been expressly supplied to operate the semitrailer's leveling jacks when the connection to the electric network is not possible. To make it work, you shall turn the pump lever (1/2) to the left.

To pump the oil you shall move alternatively the pump lever vertically and operate the distributor relative to the cylinders you have to control.

2.1.4. leveling jacks

The semitrailer is provided with four hydraulic jacks for the leveling which are separately controlled through the proper distributors (1/4).

To make the above distributor work, you shall turn the lever of the selector valve (1/10) towards the outside of the box-structure (backwards).

When power is missing and you shall operate the jacks, usually to unhook the semitrailer from the tractor, you shall use the manual pump (see chap.2.1.3. Manual pump) and turn the valve (1/9) to the left.

If you want to operate the jacks with the help of the electric pump (see chap.2.1.2. Electric Pump), the lever of the valve (1/9) shall be turned to the right.

2.1.5. axle cylinders

The semitrailer is provided with leaf springs with extractable pins which are operated by hydraulic cylinders and controlled by the proper distributors (1/5).

To make them work manually (see chap.2.1.3. Manual pump), you shall turn on the tap (1/12), usually closed, and position the lever of the valve (1/11) towards the outside of the box-structure (backwards):

On the contrary, to make them work electrically (see chap.2.1.2. Electric pump), the tap (1/12) shall be closed (with the lever turned downwards), while the valve (1/11) shall be positioned with the lever turned towards the inside of the box-structure (forwards).

2.1.6. first stage column cylinders

The first stage of the roof columns (the lowest one) is operated by volumetric cylinders through the distributor (1/6): Therefore their motion is simultaneous and they cannot be controlled separately.

To make the cylinders work, you shall position the valve (1/10) with the lever turned towards the inside of the box-structure (forwards) and you shall verify that the tap (1/13) is turned on (with the lever turned to the right).

For the manual working (see chapt.2.1.3. Manual pump), you shall position the valve (1/9) with the lever turned to the left.

For the electric working (see chap.2.1.2. Electric pump), the valve's lever (1/9) shall be turned to the right.

With the passing of time the oil contained in the closed circuit of these cylinders can flow into the tank, thus leading to a misalignment of the columns. In order to check the alignment, first of all you shall compare the position of the two columns. In doing this, please refer to the numbered marks on them.

In order to correct the misalignment you shall take the cylinders to their max. extension (by raising the columns to the max. height). With the control valve (1/10) positioned as above and after having closed the tap (1/14), you shall turn the tap (1/15) on until the column placed on the back of the semitrailer has reached its max. extension. Once the cylinders are balanced it is very important to reposition the taps (1/14)(1/15) in their original position, i.e. the first turned off and the latter turned on.

2.1.7. roof cylinders

All the remaining cylinders of the roof are controlled through the proper remote push button panel. Therefore they can work only when power is not missing and through the electric pump (see chap.2.1.2. Electric pump).

To make these cylinders work, you shall position the selector valve (1/11) with the lever turned towards the inside of the box-structure (forwards).

Therefore through the remote push button panel it is possible to operate separately the different groups of cylinders divided up as follows:

- Cylinders of the second column stage (controlled separately)
- Cylinders of the front cantilever facade
- Cylinders of the side cantilever facades
- Cylinders of the covering canvas' hoisting rods.

2.1.8. adjustments

The hydraulic system has been tuned up in our works as a guarantee for its good working.

With the passing of time, however, maybe the system will need to be adjusted. For example it could be necessary to raise the oil delivery pressure towards the cylinders. In that case you shall operate the proper pressure regulators (1/7)(controlling all roof cylinders) and (1/8) (controlling of remaining cylinders). These regulators act only on the pressure of the oil coming from the electric pump.

Proper pressure gauges placed along the hydraulic circuit give the pressure variations, usually during the working of an hydraulic control.

⚠ CAUTION: *A too high oil pressure could lead to an abrupt working of the cylinders, thus damaging the structure. It is forbidden to exceed the max. pressure of 250 bar, testing value of the system.*

2.2. SETTING-UP

Part of this ride structure is mounted on a semitrailer which form its central structure . For this reason, in order to set-up the ride, you shall position the semitrailer in the middle of the area assigned for its erection. By doing this please respect the distance from the perimeter of the ride. Don't forget that the orientation of the front side of the ride will depend on the positioning of the semitrailer. (pict.2).

Before starting to erect the structure, it is important to lay down and shim correctly the semitrailer.

⚠ CAUTION: *The consistency of the ground where the ride will be erected is very important as regards the safety and the stability of the ride. Arrange the necessary points of support (having the right dimensions) and shims considering the ground consistency (Pict.2)*

2.2.1. The trailer

The semitrailer shall be lifted off the ground to the extent that it is possible to open the perimetric supporting frames (2/1). Four hydraulic jacks have been provided for such operation. They are positioned in the front and in the back of the semitrailer (see chapt.2.1.4. leveling jacks).

⚠ CAUTION: *The four jacks shall be hoisted in a well-balanced way so that the single jack and the structure connected to it are not over-stressed.*

In order to install the ride, you must consider that the semitrailer shall be positioned at a height from the ground which is lower than the one when the trailer is on the road. Therefore you shall release the rear axles.

First you shall remove the safety R keys from the mobile pins of the leaf spring and then you shall operate the proper hydraulic control to extract the pins from their seats (See chapt.2.1.5. Axle cylinders). In this way the leaf springs are released at one end and so the semitrailer can be laid down up to the height you want.

⚠ CAUTION: *This operation shall be performed exclusively once the semitrailer has been laid down on the four leveling jacks and once it has been lifted off the ground to the extent that the wheels don't touch the pavement. If this doesn't happen, serious damages could affect the axles and the structure of the semitrailer which could run the risk of turning over.*

Before resting the trailer on the ground, you shall assemble the proper spacers connecting the perimetric supporting frames to the trailer.

To verify the correct height of the trailer from the ground, you shall check that it is laid down at the same level of the remaining structure of the base by positioning some base longerons (2/2). Then go on leveling the trailer and assembling the remaining stabilizing brackets (2/3) and arrange the necessary points of support (Pict.2)

⚠ CAUTION: *Special attention shall be paid to the leveling procedure as it plays an important role in the erection, the safety and stability of the whole structure.*

2.2.2. The roof

Now you shall start assembling the roof structure. Open the front cantilever trusses (3/1) by arranging the track's piece (3/2) for the sliding of the traverse beam (3/3). This beam is operated by an electric motor that shall be connected to the feeding panel through the proper extension. This connecting extension is provided with a reverser which allow to select the shifting direction of the beam. During traverse be sure that both beam's ends move in parallel by observing the cross-bars of the cantilever trusses. Once the outside position has been reached, this beam shall be fixed by the pins (3/4) and the brackets (3/5) expressly arranged for this operation and it shall be connected to the central structure through the proper frame (3/6).

Go on by opening the rear cantilever trusses (3/7) which shall be temporarily released.

Now you shall release the panels of the cantilever facade (3/13) by removing the spacers (3/8) placed on its lower end and loosen the locking of the facade panels by moving the safety R keys towards the end of the locking pins (3/9). In this way it is possible to open the cantilever panels (3/13) by using the hydraulic control (See chapt.2.1.7. Roof cylinders). When the cylinders of the

⚠ CAUTION: *Special attention shall be paid to the leveling procedure as it plays an important role in the erection, safety and stability of the whole structure.*

Go on assembling the frames supporting the floor panels (trestles)(5/1) which shall be inserted in their seats over the base side frames. Some of this frames can be made of two pieces that shall be assembled before fixing them to the base.

The frames located in the front part of the ride shall be connected one another at their upper end through some cross bars (5/2).

As you can notice, the frames no.9 and 19 cannot be assembled because they are obstructed by the material loaded on the semitrailer. The first frame will be assembled only when the circular track has been assembled and after all the radial arms of the cars have been positioned. The second frame will be assembled as soon as there is some space left during the floor assembling.

Now you can start assembling the floor panels (5/3) which form the connection of the different radial frames. We advise you to assemble first the rear panels beginning from No.18 and clockwise ending with No.9. Before assembling the front part of the floor, you shall assemble the painted panels to insert perimetrically between the trestles. These panels shall be fixed to the footboards by overlapping them.

Do assemble the diagonal tie bars (5/4) of the rear trestles (5/1) by inserting them in the proper pins and then assemble the perimetrical painted panels relative to the ride rear side.

Go on with the circular track (5/5) starting from the frame No.9 and anticlockwise ending with the frame No.7. However the piece No.7/9 can be assembled only once the radial arms have been positioned. If the insertion of the different pieces in the respective seats turns out to be difficult, you shall try to rise a little bit the base situated below the insertion points of the track.

Every single piece shall be fixed to the structure using the proper screw (two types). First section the screws placed on the upper side at the end of every piece.

⚠ CAUTION: *Special attention shall be paid to the perfect leveling of the joints of the different parts composing the track as every deformation can not only lead to an irregular wear of the wheels but can also cause troublesome vibration to the whole structure. A perfect leveling can be obtained by acting on the structure situated below said joints.*

Now assemble the tie bars (5/6) connecting the central body to the circular structure. In order to avoid troublesome vibrations or unwanted noise, you shall be careful about the tension of the tie bars by acting on their adjustable threaded ends.

At this point the control booth can be positioned over the frames No.19 and 20 and the front (4/11) and rear (4/12) stabilizing columns can be erected.

Acting on the correct controls of the hydraulic circuit, do lift the first stage of the roof to its max. height until the front columns (4/11) can be inserted in their proper seating. If necessary, use also the cylinders of the columns second stage.

All columns shall first be fixed at their upper end to the roof structure. Fix also their lower ends by lowering the roof.

Now it is possible to put the hydraulic columns into their operational position by lowering the 2nd stage until it rests on the 1st one and by lowering the latter until it rests on the proper spacing bars which shall be inserted in the respective seating of the columns

Do position the radial arms on the track.

2.2.4. Rotating arms

The radial arms are the main component of the rotating structure. They shall be radially arranged along the track and connected to the central rotor. The previously assembled hoist will help you.

The radial arms have been loaded inside the semitrailer so that they can be assembled in progressive order. For their correct assembling, please consider that the numeration is anticlockwise. Therefore before the arm No.1 there is the arm No. 20 and all arms shall be spaced out by the proper spacing bars.

The arms shall be assembled following the correct numeration order. You shall start with No.20, go on with No.19, 18 and finish with No.1. Be careful about the perfect fixing of the arms to the central rotor through the proper threaded pins that should be greased when required.

Check also that the respective nuts are secured with the proper R keys.

All motive arms shall be electrically connected to the proper sockets (6/1) placed on the central rotor while the air pipes shall be connected to the proper ring-shape manifold (6/2).

The last two arms (No. 2-1) shall be temporarily arranged respectively at the side of the arms No. 4 and No. 1 as the piece of track on which they should rest is steel lacking. Do leave the necessary space to insert the lacking track.

⚠ CAUTION: *Considering the unsafe position of the arms, we advise you to fix them to the other arms using ropes or belts.*

Only once the remaining frame No.8, the respective perimetric painted panels, the respective footboards and the remaining piece of track No.7-9 have been assembled, you can start to arrange the arms which have been previously put aside.

The motors of the motive arms are equipped with a brake which prevent them from rotating when power is lacking. If it is necessary to manually move an arm along the track, you shall release the brake by turning clockwise the knob of the manual release device.

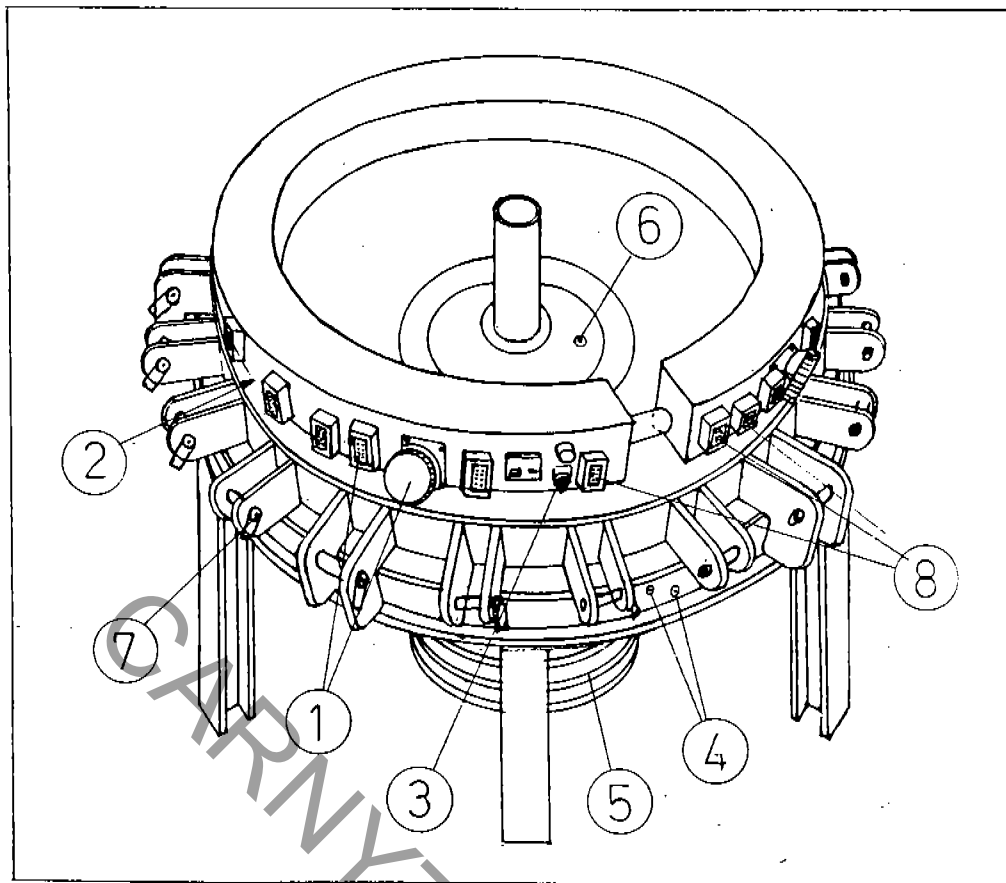

PICT. 6

2.2.5. Cars

The cars of this ride are loaded inside the semitrailer already assembled. You only need to rest them on the proper seating of the radial arms.

Please consider that the normal direction of rotation of the ride is clockwise and that the cars shall be arranged following the numeration order of the arms.

The front hooks of the cars shall be inserted into the most outside seating of the arms while the rear ones shall be inserted in the most inside ones.

While assembling the cars, you shall remove the spacing bars which had been previously placed between the arms. Be careful about the connection to the air pipes.

All cars shall be secured by the proper pins to be inserted in the respective bushing.

Each car is provided with a fan-shaped mechanism which will act as a support for the folding top. It shall be inserted in its seating on the rear side.

2.2.6. miscellaneous

The arm-covering canvas can now be laid down. This canvas shall be laid out so that the seams of the different sectors forming the canvas coincide with the arms below. It shall be fixed in the middle with an elastic rope.

Over the canvas, in proximity of each arm, there are some lighting bars which shall be secured with the proper R keys and electrically connected to the distribution board on the central rotor (6/8). The cables fixed to the other end of the lighting bars shall be connected to the cars

⚠ CAUTION: *The lighting bars also act as electric connection for the cars. They control the lighting and the operation of the safety grips.*

Over the central rotor there is a decorative crown consisting of two pieces that shall be connected to the proper electric socket placed here.

Now you can start assembling the perimetric fences and the rear perimetric canvas. This shall be fastened to the roof structure.

Do assemble the remaining decorative panels of the front and central columns.

2.2.7. Useful electric controls

During the installation of the arms and of the cars, the use of the electric controls could turn out helpful if you want to move the arms along the track. This can be done only after having installed the first 4-5 arms or at least 1 motive arm.

⚠ CAUTION: *This operation is very delicate and at the same time dangerous. The slightest absent mindedness or indecision could lead to serious damages.*

Following the instructions contained in chapt. 4.1 "Control panel" and 4.2 "Ignition", do start the inverter (7/8). At this point you shall adjust the potentiometer (7/40) at 10%, rotate the switch "rapid stop" (7/14) on position "1" and press the start button of the ride. The ride will not start rotating until the switch of rapid stop (7/14) is again on position "0". To stop the ride again, you only need to set again the switch on position "1". In case of emergency it is always possible to press the proper push button (7/13).

On the ring-shaped plug board fixed on the central rotor, in proximity to the electric motors sockets (6/1), some selector switches (6/3) have been arranged. During the normal working of the ride, these selector switches shall remain on position "0". However as soon as the respective electric motor is disconnected, they shall be set on position "1". Actually if the selector switch is left on position "0" and the respective motor is disconnected, the ride cannot be operated.

⚠ CAUTION: *Before acting on the electric controls, make sure that the manual release device of the motors connected to the electric system is disconnected; otherwise the arms could move in an uncontrollable way.*

2.3. DISASSEMBLY PROCEDURE

⚠ CAUTION: *Make sure, with exception of the hydraulic system, that the ride is disconnected from the electric network. Do not proceed with the disassembling operations if power is still present.*

In order to disassemble the ride you shall follow, in the opposite direction, the setting up procedure described above.

Once the pins, screws, pivots etc. have been disconnected, we advise you, where possible, to leave them inserted in their housing. We advise you to gather all the remaining pins, screws, pivots etc. of the same type in separate containers in order to avoid any confusion during the next setting up.

If the ride is not being operated for a long period, before its disassembling, lubricate all parts and let it rotate for a short period so that the grease can spread all over the sliding surface.

3. OPERATION OF THE RIDE

3.1. THE CONTROL PANEL

Through the control panel it is possible to carry out all functions of the ride including the switching off and on of the lights and the disconnection from the electric network.

The picture below illustrates the arrangements of the different switches and pilot lamps as well as their function.

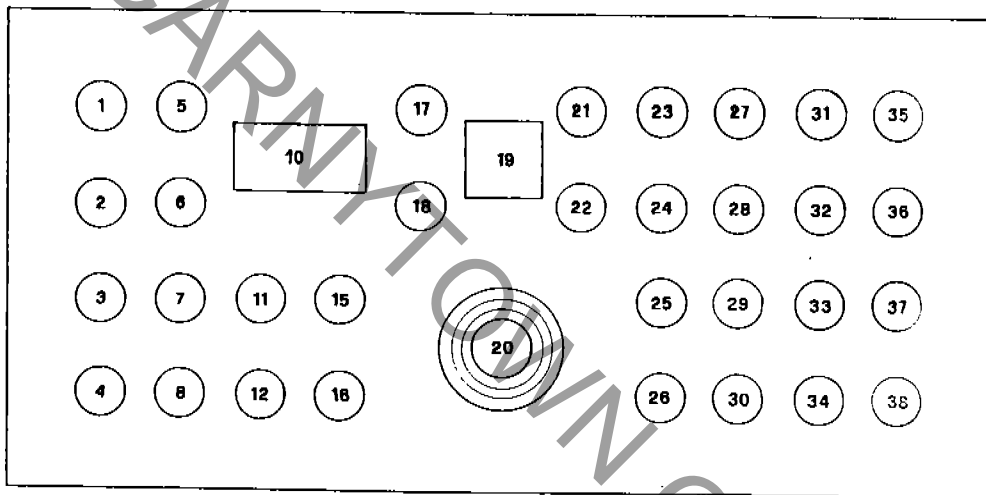

PICT. 7

- | | | |
|------------------------------|-----------------------------|----------------------------|
| 1) C. PANEL MAIN SWITCH | 16) BRAKES "OFF" LAMP | 28) CEILING LIGHTING |
| 2) M. POWER DISCONNECTION | 17) AUTOMATIC OP. MODE L. | 29) AUXILIARY LINE 1 |
| 3) LIGHTING DISCONNECTION | 18) OPERATING MODE BUTT. | 30) AUXILIARY LINE 4 |
| 4) FUSE (10 A) MOT. POWER C. | 19) TIMER (AUTOM. MODE) | 31) INSIDE FACADE LIGHTING |
| 5) EMERGENCY STOP | 20) JOY STICK | 32) ARMS / CENTER LIGHTING |
| 6) F. CONVERTER SWITCH | 21) MANUAL OP. MODE LAMP | 33) UPPER FACADE LIGHTING |
| 7) EMPTY | 22) SIREN BUTTON | 34) LOWER FACADE LIGHTING |
| 8) "RIDE ON ROTATION" LAMP | 23) CARS LIGHTING | 35) RIGHT COLUMN LIGHTING |
| 10) RIDE SPEED DISPLAY | 24) LEFT COLUMNS LIGHTING | 36) CANTILEVERED FACADE L. |
| 11) LOW SPEED ROTATION SW. | 25) UPPER FASCIA LIGHTING | 37) CENTER'S SPOT LIGHTS |
| 12) F. CONVERTER RESET | 26) FUSE (10 A) LIGHTING C. | 38) EMPTY |
| 15) JOYSTICK CUT-OUT | 27) AUXILIARY LINE 3 | |

3.2. IGNITION

Please refer to the picture 7 to locate the different switches.

- Acting on the control panel, turn on the feeding switch (7/2) using the proper key and check the switching on of the pilot lamps of the electric line coming from the network (7/4) and/or from the generating set (7/5) and of the frequency numerical display (7/38).
- Start the compressor by turning the proper selector switch (7/9). Its starting will be confirmed by the switching on of the respective pilot lamp (7/6).
- Start the inverter by turning the switch (7/8). It will be confirmed by the switching on of the respective pilot lamp (7/17). We advise you to check its actual switching on by verifying the working of the inverter cooling fans and the turning on of its display. This equipment has been tuned up by our engineers and no additional adjustments are necessary.

▲ CAUTION: *Do never operate the inverter if at least one of the ride's motors is connected to the feeding circuit.*

When you switch on the inverter, the pilot lamp (7/7) should also turn on indicating its good working. In case the inverter were malfunctioning, the above pilot lamp should turn off and the state of alarm would be signalled by the switching on of the proper red pilot lamp (7/10).

The state of alarm can be annulled by acting on the proper reset push button (7/11). If the state of alarm is presenting again you shall refer to the inverter manual to find out the problem.

- The motors are supplied with a device for the brake manual release. Before operating the ride make sure that all brakes are active (be sure that the proper screw on the motor is loosened). To check their proper working you can make use of the brake electric release control (7/15). The working of the brakes is confirmed by their noise during lock/release operations. The operation of the manual release control is confirmed by the switching on of the respective red pilot lamp (7/20).

The cars of the ride are supplied with canvas folding tops which are pneumatically operated and controlled by the proper red push button (7/27). This canvas wraps the cars up isolating the passengers from the outside world.

▲ CAUTION: *Do never operate the control of the folding tops when the ride is not working and especially during loading and unloading of the passengers or when the same are not properly sitting inside the cars.*

- Select the direction of rotation 0-clockwise or 1-anticlockwise by acting on the selector switch (7/12). The direction of rotation can be changed also during the working of the ride, aside from the selected working mode.

3.3. MANUAL OPERATION

- By turning the proper selector switch (7/16) on the position 1-Manual, you select the modality of manual operation.
- Start operating the ride by acting on the proper push button (7/18). The red pilot lamp of the brakes (7/20) will light on, thus indicating their release, and the ride will begin to rotate slowly increasing progressively its speed until it reaches the operation speed.
- The operation speed of the ride ranges at will from 0 to 14 revolutions per minute by means of the potentiometer (7/40).
- During operation, it is possible to reverse the direction of rotation of the ride by acting on the selector switch (7/12). In this way the ride will automatically reduce its speed until it has stopped and then it will rotate in the opposite direction picking up speed until it will reach its operation speed.

The ride can be stopped acting on the proper push button (7/21).

⚠ CAUTION: *Never use the potentiometer to stop or reverse the direction of rotation of the ride.*

Before re-operating the ride, make sure that the red pilot lamp of the brakes (7/20) is switched off. If this is not the case, do wait its turning off.

3.4. AUTOMATIC OPERATION

The ride can be operated semiautomatically giving you the possibility, during the pre-set time to perform all manoeuvres typical of manual operation.

- By turning the proper selector switch (7/16) on the position 2-Automatic, you select the modality of automatic operation.
- Select the duration of the cycle by acting on the timer (7/42). The selected time is kept until future changes are made.
- Start operating the ride by acting on the proper push button (7/18). The ride begins to rotate slowly increasing progressively its speed until it reaches the operation speed. During the cycle you can perform all manoeuvres typical of the manual operation (stop, reversal, adjustments of the speed) until the pre-set time is over and the ride stops automatically.

3.5. LOADING AND UNLOADING PROCEDURE

The loading and unloading of the public shall take place only when the ride has come to a full stop. For safety reasons the ride has been provided with a sound signal (siren), operated by acting on the control board (7/26). We advise you to use this signal for warning the public of the imminent working of the ride or of the end of the cycle. Therefore the public shall be warned not to get off the cars before the signal -end of cycle- has sounded and get on the cars after the signal -begin of a new cycle- has sounded.

Do arrange the passengers on the ride as uniformly as possible and try to balance the load. Pay attention that the smaller and/or lighter passengers are sitting on the inside of the ride in order to prevent them from being crushed from the other passengers.

Before operating the ride make sure that all passengers are properly sitting inside the cars, that all safety grips are properly locked and that the public has left the approaching footboards. The locking and the release of the safety grips, when they are in the position "closed", is possible by turning completely the proper handle.

To prevent the risk of intentional or accidental opening of the grip during the operation of the ride, a remote locking device has been provided. It is operated by acting on the control board (7/24). Once the grips are locked, it is not possible to open the cars'grips until this control has been disconnected. The actual locking of the grips is confirmed by the switching on of the proper pilot lamp on the proper board (7/23) and by the lighting on of the single pilot lamps present on each car. If this locking is not confirmed, it is possible to find out the grip which is not correctly closed by checking the pilot lamps of the cars. Following the anticlockwise order, do locate the first car having the pilot lamp turned off and check the locking of the grip.

⚠ CAUTION: *The remote release device is pneumatically operated. Therefore you shall operate the compressor to make it work. If it is necessary to move the ride forward during the loading procedures, you shall behave as follows:*

Set the potentiometer (7/40) at value 20% and operate the ride by selecting the manual modality (see chapt.3.3.) Once the position you want has been reached, do stop the rotation by acting on the proper control (7/14). To re-operate the ride also for a successive shifting, you only need to position the selector switch (7/14) in the original position without having to operate the start control (7/18).

Every day, before opening the ride to the public, the equipment shall rotate for some time without passengers and its good operation must be checked.

Make sure that all passengers are correctly sitting during the working of the ride.

3.6. EMERGENCY

In case of emergency, the control board is provided with an emergency push button (7/13). If pressed, it causes the immediate stop of the ride and the operation of the brakes. In order to make the ride rotate again after an emergency stop, you shall turn the emergency button clockwise and go on following the description of the paragraph 3.2. "Ignition".

⚠ CAUTION: *Please consider that the emergency stop of the ride is caused by the disconnection of the electric motors and the respective brakes which work mechanically through springs. Therefore the ride stop depends on the good functioning of all brakes which shall be free to operate (check that the manual release devices are disconnected).*

The emergency control cuts off only the power of the motive electric motors of the ride without acting on the other controls. If necessary, it is possible to cut power off the whole ride by pressing the proper red push button (7/1) which lead to the disconnection of the main switches of the lighting and of the motive power.

3.7. POWER BLACKOUT

When power is missing, the ride stops as in case of emergency.

In order to make it rotate again, when power is present, we advise you to turn off all buttons of the control board and to follow the procedures described on the paragraph 3.2. "Ignition".

3.8. LIGHTING

The lighting of the ride is divided into different lines separately controlled. Some of these lines are connected to electronic gearcases.

The lights of the cars as well as of all their electric components are operated at the voltage of 24 V and are connected to a transformer. To turn on the cars lights you shall act on the proper switch (7/19).

The remaining lighting is divided into: lighting of the rotating arms (7/25), lighting of the central crown (7/22), lighting of the inside facade (7/36), lighting of the roof (7/32), lighting of the lower facade (7/29), lighting of the cantilever facade (7/30), lighting of the upper facade (7/33), lighting of the upper facade (7/35) lighting of the sign (7/28), clear lighting of the sign (7/37) and outside lighting of the booth (7/34).

4. SERVICE

4.1. CENTRAL ROTOR

4.1.1. Fifth wheel

The fifth wheel (6/4) shall be lubricated after 100 hour operation using a proper grease (see table below). Grease, however, shall not contain acids and resin, shall not be hydroscopic and shall not be altered by changes in temperature. Before and after a long period of non-operation, an additional lubrication is strictly required. It is necessary that the grease coming out of the rings forms a collar all around the fifth wheel.

After 12 month please check the tightening torque of the fifth wheel's bolts by using the proper dynamometric wrench and tighten them as indicated in the table according to the diameter of the different screws. An initial test, however, shall be carried out after the first 100 operating hours.

4.1.2. Electric contacts

Every 500 hour operation check the parts easily wearing out (carbons). Replace the carbons when they cannot perfectly adhere to the slip ring (6/5) and take care of the correct electric connection.

4.1.3. Pneumatic rotating joint

This rotating joint enables the compressed air coming from the tank, fixed on the semitrailer, to be sent to the rotating cars. It rests on bearings (6/6) which shall be monthly lubricated.

Inside the rotating joint there are grommets which shall be constantly lubricated by adding oil to the air going through it.

After a long period of non operation or before starting the ride after a long period of non operation, we advise you to increase the oil metering in the air in order to let it flow through the rotating joint. In this way the gaskets will not deteriorate with the passing of time.

4.2. ROTATING STRUCTURE

4.2.1. Arms

Every 100 operating hours lubricate the pivots connecting the arms with the central rotor (6/7) check every day their good condition and make sure that all split pins are properly secured.

Check every day the state of conservation of the wheels by verifying their wearing and the lack of possible cracks or defects of the rotating surface.

Check monthly the wearing of the driving belts connecting the electric motors to the motive wheels and if necessary adjust their tension by acting on the proper tighteners.

Before a long period of non operation of the ride, especially if stationary-installed, we advise you to lift all the arms off the track by fitting some shims in order to avoid a possible ovalization of the wheels.

At intervals check the whole structure in order to make sure that there are no cracks or breaks.

4.2.2. Cars

Please check every day the good condition of the safety grips, the correct working of the closing device and of the respective locking mechanism, and if necessary lubricate them. Check that all pins and pivots connecting the cars to the arms are in their seat and are secured by the proper R keys.

Every week or when the ride is installed at a new location, lightly grease the joints connecting the cars to the radial arms.

Check monthly all pins and screws connecting the different parts of the cars.

4.3. HYDRAULIC CIRCUIT

The hydraulic circuit of the ride has been planned only for the assembly and disassembly procedures. We advise you to replace the hydraulic oil every 24 months. For the replacement of the oil, the cleaning of the hydraulic system and its re-starting do apply to qualified and expert persons. Please refer to the table below to select the correct oil.

4.4. PNEUMATIC CIRCUIT

The pneumatic circuit of the ride is used for the working of the folding tops of the cars and of the locking device of the safety grips.

The compressor feeds the air tank with a pressure of 8 bars that is reduced to 4-5 bars in the brake's feeding circuit.

Outside the tank there is a pressure lubricator/reduction unit that is used for adjustment of the system's pressure (4-5 bars) and for the lubrication of the air. The above pneumatic controls are lubricated by the oil present in the air. We advise you to periodically check the correct pressure value indicated by the proper manometer (8/2) (to be adjusted through the proper knob (8/1)) as well as the oil level in the lubricator (8/3). For a successive topping up do use only oils for pneumatic systems.

⚠ CAUTION: Both the controls on the cars and the pneumatic rotating joint on the central rotor of the ride shall be frequently lubricated by the oil metered in the air. If this is not the case, the gaskets would wear out and the air of the circuit would be reduced.

After the first 100 operating hours, we advise you to replace all the oil in the compressor and to check and tighten all screws, especially the ones on the head. Oil shall always be replaced every 12 operating months.

Furthermore the oil level shall be checked every week through the proper dipstick (8/4).

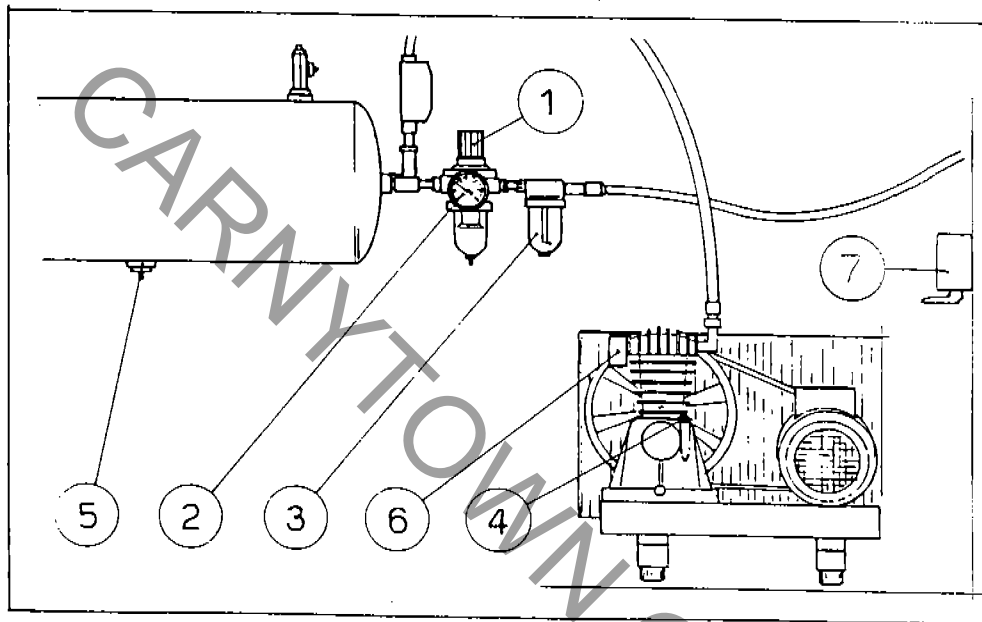

PICT. 8

Usually once a week, it is necessary to drain the water from the air tank by acting on the proper valve (8/5) as the air compression makes some condense deposit on the bottom of the tank.

For the good working of the compressor, we advise you to clean the filter element (8/6) every month and to replace it once a year.

After 2000 operating hours or 2 years you shall clean the suction and delivery valve and control the check valve.

⚠ CAUTION: Before starting the maintenance of the compressor, make sure it is disconnected and that the tank is empty.

4.5. STATIONARY STRUCTURE

During the setting-up of the ride lock all the pivots with the proper nuts and/or split pins.

Check the tightening of all screws by using the proper dynamometric wrench. Please see table of the screws class 8.8 (8G).

Every week make sure that the track is properly secured in its position and if necessary check the leveling of the base.

Every year check the leveling of the base and the condition of the whole structure. All pins shall be secured with the proper split pins and all bolts shall be properly tightened. Also check the state of conservation of the whole structure in order to avoid corrosion. If necessary use a proper paint.

The anchor points of the ropes to the central rotor shall be greased every 100 hours through the proper grease nipples.

4.6. PERIODIC CHECK-LIST

Refer to the chapters regarding the point of intervention in order to obtain more information on the single intervention.

EVERY DAY

Check all pivots and make sure they are secured with their split pins. Pay special attention to the pivots connecting the cars to the arms.

Check the good condition and integrity of the safety grips and make sure that all moving parts are lubricated.

Check the connection of the radial arms to the central rotor and make sure that the pins are secured with the proper split pins.

Check the state of conservation of the wheels of the radial arms and verify their normal wear.

EVERY WEEK

Check the state of conservation of each part of the central rotor and verify that all pins are secured with the proper split pins.

Make sure that the track is properly secured in its position and if necessary check the leveling of the base.

Check the pressure of the pneumatic system as well as the oil level into the lubricator/reduction unit of the compressor.

Drain the condense from the compressor's tank.

EVERY MONTH

Clean the filter element of the compressor.

EVERY 500 HOURS

Check the normal wear of the brushes of the central rotor.

EVERY YEAR

Carry out very carefully all the above-described tests.

Check the whole structure and check the fastening of all bolts, especially the bolts of the central fifth wheel.

Replace the filter element of the compressor.

Before a long period of non-operation of the ride, it is necessary to lift all the arms off the track by fitting some shims in order to avoid the ovalization of the wheels.

SPECIAL INSPECTION

After the first 100 operating hours check the tightening of the screws of the central fifth wheel and of the compressor.

4.7. PERIODIC LUBRICATION

A regular lubrication is important to guarantee the long life and the safe operation of the equipment.

It is important to use only proper lubricators.

Refer to the chapters regarding the point of intervention in order to obtain more information on the single intervention.

DURING SETTING-UP

Grease all pivots connecting the radial arms, the wheel spindles and the central bearing.

Grease the joints connecting the cars to the radial arms.

EVERY 100 HOURS

Grease the pivots connecting the radial arms.

Grease the joints connecting the cars to the radial arms.

Grease the central fifth wheel.

EVERY 12 MONTH

Replace the oil in the compressor.

SPECIAL LUBRICATION

After the first 100 operating hours, replace the oil of the compressor.

Before and after a long period of non-operation, grease all parts of the equipment and let the ride rotate for a short period so that the grease can spread all over the sliding surface.

CARNYTOWN.COM

Tightening torque in Nm for screws class 8.8							
Screw tread	Tightening value	Screw tread	Tightening value	Screw tread	Tightening value	Screw tread	Tightening value
M 2	0,29	M 10	48,05	M 22	539,3	M 39	2991
M 3	1,08	M 12	84,33	M 24	696,2	M 42	3726
M 4	2,50	M 14	132,3	M 27	1029	M 45	4658
M 5	4,91	M 16	205,9	M 30	1421	M 48	5589
M 6	10,78	M 18	284,3	M 33	1765	M 52	7207
M 8	25,49	M 20	402,0	M 36	2304	M 56	8973

TAB. 1

LUBRICANTS LIST						
Application	Lubricant Type	Temp. °C	BP	ESSO	IP SHELL	MOBIL
Hydraulic circuit	oil		ENERGOL HLP 32	NUTO H 32	TELLUS OEL 32	DTE28 Hidr H LPD 32
Bearings	grease	-30 /+120	ENERGREASE LS 2	BEACON 2	ALVANIA R2	MOBILUX 2

TAB. 2

5. ▲ WARNINGS

The owner/operator of the ride must respect the following instructions:

- During the assembling of the ride all pins shall be secured with the proper split pins;
- The employee operating the ride shall be of age and experienced;
- All active and passive safety systems safeguarding the public shall work to perfection whenever the ride begins working and during its operation;
- The max. rotation speed shall not exceed 14 revolutions per minute;
- Admission to the ride shall be permitted to a number of persons that does not exceed 40 / 60 (adults / childs) units;
- The ride shall not be operated until all passengers are sitting into the cars in the proper and correct position and the safety grips are put in the proper position and the public has left the approaching footboards;
- No admittance to persons who are not in full possession of their physical and mental faculties;
- No admittance to children under the age of 12 and shorter than 1.30 m (52") unless they are accompanied and helped by their parents;
- The ride shall be equipped with dry chemical fire extinguishers in compliance with local regulations;
- The ride shall have signs posted at the entrance indicating the age and the physical features that are necessary for the admittance to the ride and signs such as: "No smoking", "Do not lean out of the car", "Do not stand up", "Hold both feet inside the car", "Hold the safety grip tightly", "Do not get in and out the car until the ride has completely stopped", "Do not bring objects, animals or food on board the car".

Every year the ride shall be subjected to extraordinary overhaul and maintenance by skilled technicians. It is strictly forbidden to modify structures and safety systems unless the manufacturing firm gives its written assent. Every modification shall be justified by a certification of static fitness and of prevention given by a qualified technician.

The owner/operator shall install the ride properly, shall inspect it, shall regularly check its state of preservation and control the proper working of the ride before its opening to the public. He is therefore responsible for the fulfilment of the above-mentioned duties.

This manual shall always be handed to new owners/operators.

6. TECHNICAL DATA

6.1. GENERAL FEATURES

Manufacturer:..... BERTAZZON 3B srl - Sarnola - (TV) - ITALY
Ride name:.....SUPER HIMALAYA SR-T2
Serial number:..... ME - 98 - 01 - RS
Date of manufacturing:..... 1998
Ride maximum speed:..... 13,5 RPM
Direction of travel:.....CLOCKWISE - ANTICLOCKWISE
Maximum operating wind:..... 14m/s (30MPH)

Passenger capacity (adults/children) and loading weight per:

car :	No. 2 /3	passengers	1,5 kN	(330 Lbs)
Ride :	No. 60 / 60	passengers	45 kN	(9900 Lbs)

6.2. OPERATIONAL LIMITATIONS

State any other passenger limitations restricting use of the device:

- No admittance to passengers under the age of 12 and shorter than 1,3 m (52"), if not accompanied and helped, or passengers who cannot be properly contained inside the cars;
- Person who are not in full possession of their physical and mental faculties, if not accompanied and helped;

6.3. ELECTRICAL POWER REQUIREMENT

a) Motive Power:	Voltage:	V 210 \pm 5%
	Phase:	L1 - L2 - L3 - N - PE
	Power:	KW 30
b) Lighting:	Voltage:	V 110 \pm 5%
	Phase:	L1 - N - PE
	Power:	KW 35
c) Frequency:		Hz 60

6.4. PRINCIPAL OPERATIONAL DIMENSIONS

a) Maximum Length:	17,6 m (58')
a) Maximum Breadth:	16 m (53')
b) Maximum Height:	8,5 m (28')
c) Weight empty:	400 kN (88000 Lbs)
d) Weight full:	430 kN (95000 Lbs)