



PRODUCT CODE 297013
CODE PRODUCT 353293

ARM
"Ali Baba"
Non-Kiddie

OPERATION AND MAINTENANCE MANUAL

CARNY TOWN.COM

'ALI-BABA'

THIS RIDE IS ALSO KNOWN AS
"1001 NIGHTS", THIS MANUAL CAN
BE USED FOR THE SINGLE Gondola
"HIGH FLYER"

TYPE DESIGNATION

TYPE DESIGNATION:

'ALI BABA'

SERIAL No.:

AB37/04/10/97USA

MONTH OF MANUFACTURE:

OCTOBER

YEAR OF MANUFACTURE:

1997

MANUFACTURER:

A.R.M. (U.K.) LTD.

ADDRESS:

UNIT 1, ENSTONE AIRFIELD
ENSTONE
OXON
ENGLAND

CARNYKTOWN.COM

		mm	ins
Length	Travelling	14,975	589
Width	Travelling	2,590	102
Height	Travelling	4,111	161
Length	Erected	16,385	645
Overall Width	Erected	4,590	181
Height Swept By Car	Erected	16,075	633
Height To Top Of Machine	Erected	9,750	384
Height Of Decking	Erected	1,400	55
Car Depth Front To Back	Erected	1,500	59
Car Length End To End	Erected	6,100	240
Clearance To Any Adjacent Ride	Erected	1,000	39
		kg	Lbs
Weight Gross	Travelling	28,500	62,757
Passenger Weight Per Car	Erected	1,695	3,730
Passenger Weight Total	Erected	1,695	3,730
Loaded Weight Of Machine	Erected	30,195	66,490
Load On Footings (Worst Case)	Erected	9,200	20,250
Direction Of Rotation	Erected	Clock Or	Anticlock
No Of Passengers Per Car	Erected	22-No	
Average Design Speed Of Rotation	Erected	10 rpm	

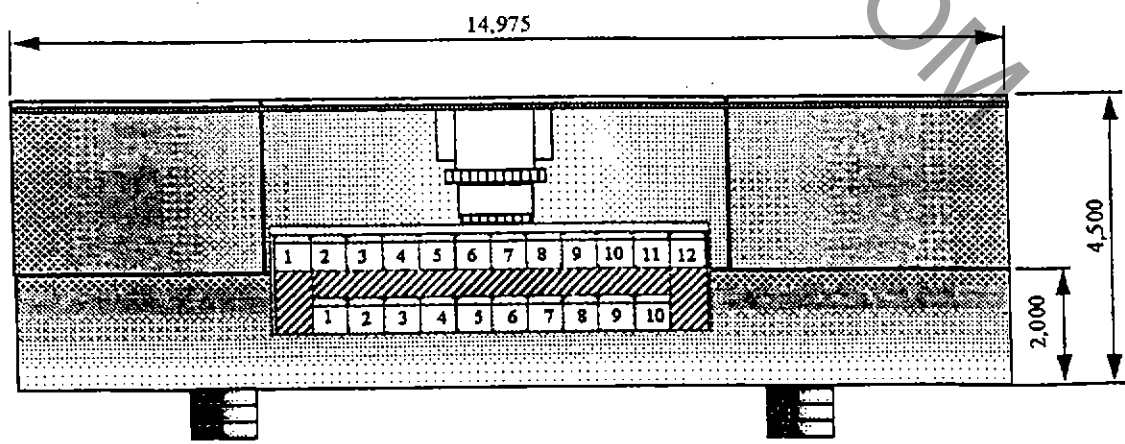
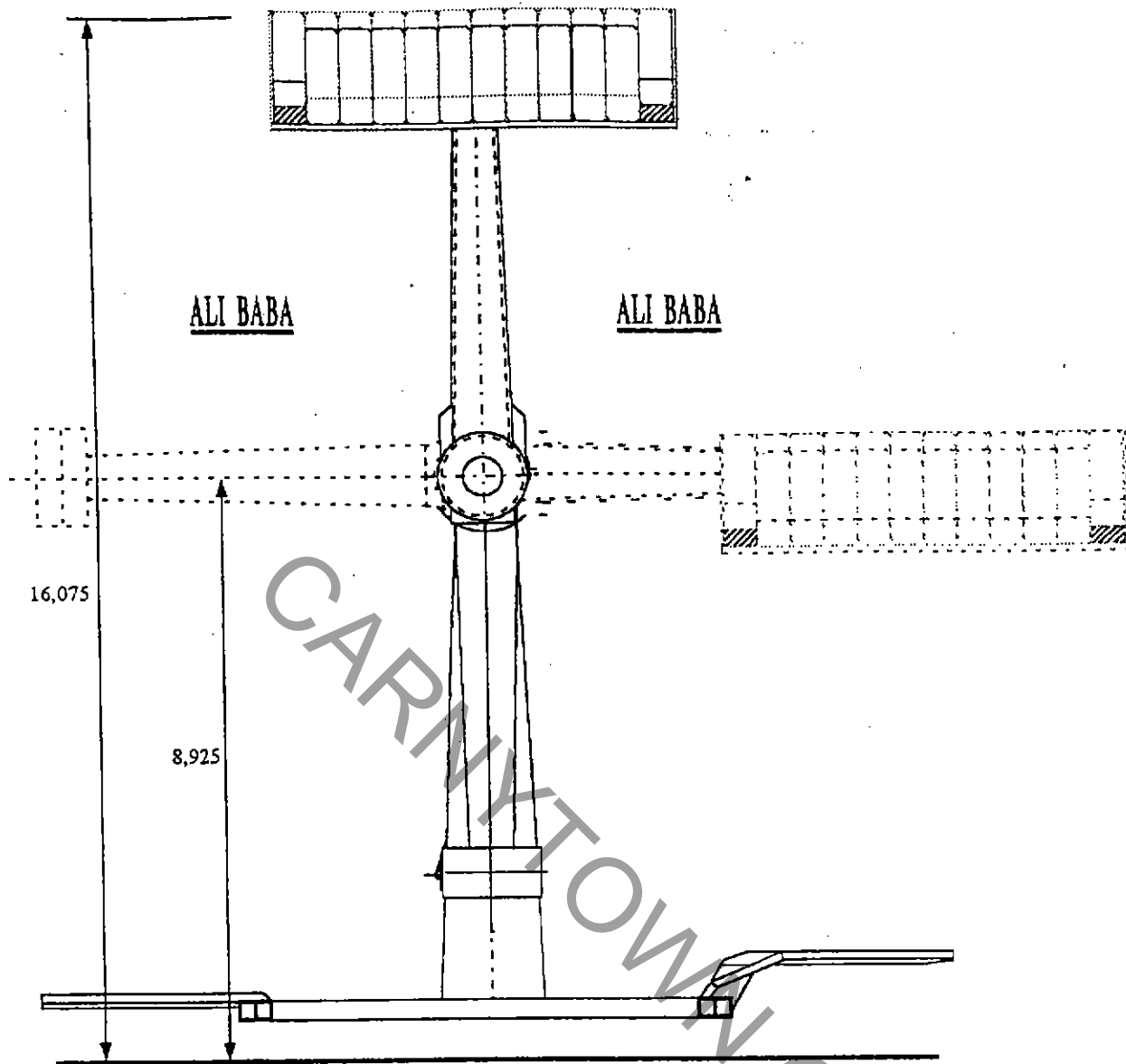

SECTION 2

DESIGN SPECIFICATION

CARNYTOWN.COM

Overview of "Ali - Baba" Amusement Ride.

The Ali - Baba amusement ride is of the fully mobile type all being carried on a single road going trailer comprising of fold out floor, fold out flash panels, lighting etc. and being erected in some 120 minutes.

The ride is capable of one man operation but when busy it is intended to use an assistant to shepherd the passengers and check passenger security, a pay box is situated to the rear of the ride giving maximum visibility and control of the passengers and ride. Steps and queuing rails are provided giving a smooth thro put of passengers with an orderly queuing system thus providing crowd control and safety.

The ride motion is derived from a single rotating arm carrying the passenger car at the extreme outer end. The arm is counterbalanced by a counterweight which counterbalances the unladen weight of the arm and car. The main arm is attached to a slewing ring which is mounted on a horizontal axis and driven by a single electric motor the drive being taken by propshaft to a bevel reduction gearbox and pinion to the slewing ring. Control is provided by a computerised electronic control unit which gives total programmable control over the motor speed and torque output both driving and in the overrun condition and also allows optimum conditions for the initial swinging phase.

To Maintain the horizontal attitude of the car an independent drive system is fixed to either side of the main arm comprising twin bevel gearboxes and propshafts. The gearbox pinions are constrained to rotate about a fixed stationary ring at the inner end and the car slewing ring at the outer end the duplication of this arrangement ensures total safety in the event of a failure by any one system.

The effect of this arrangement is to provide a rotating system so that each passenger is constrained to rotate about a fixed point centered on a horizontal center line drawn through the slewing ring or point of rotation. Passengers are seated in an upright position and constrained from free movement by a fully adjustable lap bar which is pivoted about a point above the passengers head, thus providing full upper body restraint.

The maximum dynamic accelerations at full speed are in the order of 0.75 'g' at the top most position and 2.5 'g' at the lower most position and the resultant forces combined with the circular motion combine to give an exciting and robust ride which has proved to be very popular with the public. All controls are situated in the pay box and grouped in a single control panel giving ease of operation and providing excellent control. The main rotary movement of the ride is controlled by a forward and reverse joystick.

Thro-put in the order of 350 passengers per hour is readily achieved with an experienced operator and loading/unloading is in the order of 30 seconds max. Ride capacity is 22 passengers and ride operating speed is 10 rpm average speed dynamic braking is achieved via the main electronic control system and drive motor while parking is achieved by pneumatic drum brake and mechanical system inertia.

Dismantling the ride is achieved by folding the counterbalance weight, folding flash panels and folding floor, power systems to achieve this are all provided on board. the whole ride when folded has the appearance of a drop sided vehicle.

Design Standards Used.

Standards complied with or exceeded.

Health and Safety Executive Code Of Practise (current draft copy)

Health and Safety Executive Code Of Practise 1984.

ASTM Amusement Rides and Devices 1987.

Structural standard		BS 5400 PT 10
Material specification	Plate	BS 4360 - 43A.
Material specification	Hollow Sections	BS 4360 - 43C
Material specification	Bright Bar	BS 970 - EN8

Minimum Static Safety Standards

Min static F.O.S. on yield of any fully loaded structure	3 : 1
Min Static F.O.S on ultimate shear stress	10 : 1
Min Static F.O.S. on ultimate tensile stress	10 : 1

Minimum Material Specification.

	Yield	U.T.S.
All Plate and Rolled Sections	240 n/mm ² (15 tons/in ²)	430 n/mm ² (28 tons/in ²)
All Hollow Sections	255 n/mm ² (16 tons/in ²)	430 n/mm ² (28 tons/in ²)
All Bright Bar and Fixing Pins	280 n/mm ² (18 tons/in ²)	540 n/mm ² (35 tons/in ²)
All I.S.O. Bolts Grade 8.8	530 n/mm ² (34 tons/in ²)	750 n/mm ² (48 tons/in ²)

I.S.O. (Grade 8.8) Bolt Maximum Torques Based On 85% Proof Stress (Do Not Exceed)
For other specific torque requirements see pages 3.04, 3.08 & 3.10

M 6	11 n.m	(9 lbs.ft)
M 8	28 n.m	(21 lbs.ft)
M10	56 n.m	(41 lbs.ft)
M12	98 n.m	(72 lbs.ft)
M16	244 n.m	(180 lbs.ft)
M20	476 n.m	(351 lbs.ft)
M24	822 n.m	(606 lbs.ft)
M30	1633 n.m	(1204 lbs.ft)
M36	2854 n.m	(2105 lbs.ft)

Note:-

Torques shown are for bolts in the unplated condition with marginal lubrication only and using flat washers under the mild steel nut, torques to be rechecked after running ride empty for three minutes to allow for bedding in of threads and washer etc.

		mm	Ins
Length	Travelling	14,975	589
Width	Travelling	2,590	102
Height	Travelling	4,111	161
Length	Erected	16,385	645
Overall Width	Erected	4,590	181
Height Swept By Car	Erected	16,075	633
Height To Top Of Machine	Erected	9,750	384
Height Of Decking	Erected	1,400	55
Car Depth Front To Back	Erected	1,500	59
Car Length End To End	Erected	6,100	240
Clearance To Any Adjacent Ride	Erected	1,000	39
		kg	Lbs
Weight Gross	Travelling	28,500	62,757
Passenger Weight Per Car	Erected	1,695	3,730
Passenger Weight Total	Erected	1,695	3,730
Loaded Weight Of Machine	Erected	30,195	66,490
Load On Footings (Worst Case)	Erected	9,200	20,250
Direction Of Rotation	Erected	Clock Or	Anticlock
No Of Passengers Per Car	Erected	22-No	
Average Design Speed Of Rotation	Erected	10 rpm	

Max passenger time per ride	3.0	Min
Min passenger height	1220	mm (48 ins)
Force on passengers outwards from centre @ B.D.C	2.5	'g'
Linear velocity of passengers @ max radius	34	kph
Drive motor torque @ max passenger load	280	nm
Motor power @ max passenger load	64	kw
Max imbalance when full	0.0	%
Max deviation from horizontal when erected	2.5	± Deg
Max deviation from vertical when erected	1.5	± Deg

SECTION 4

OPERATION AND CONTROLS

CARNYTOWN.COM

Control Box Manual and Automatic Version

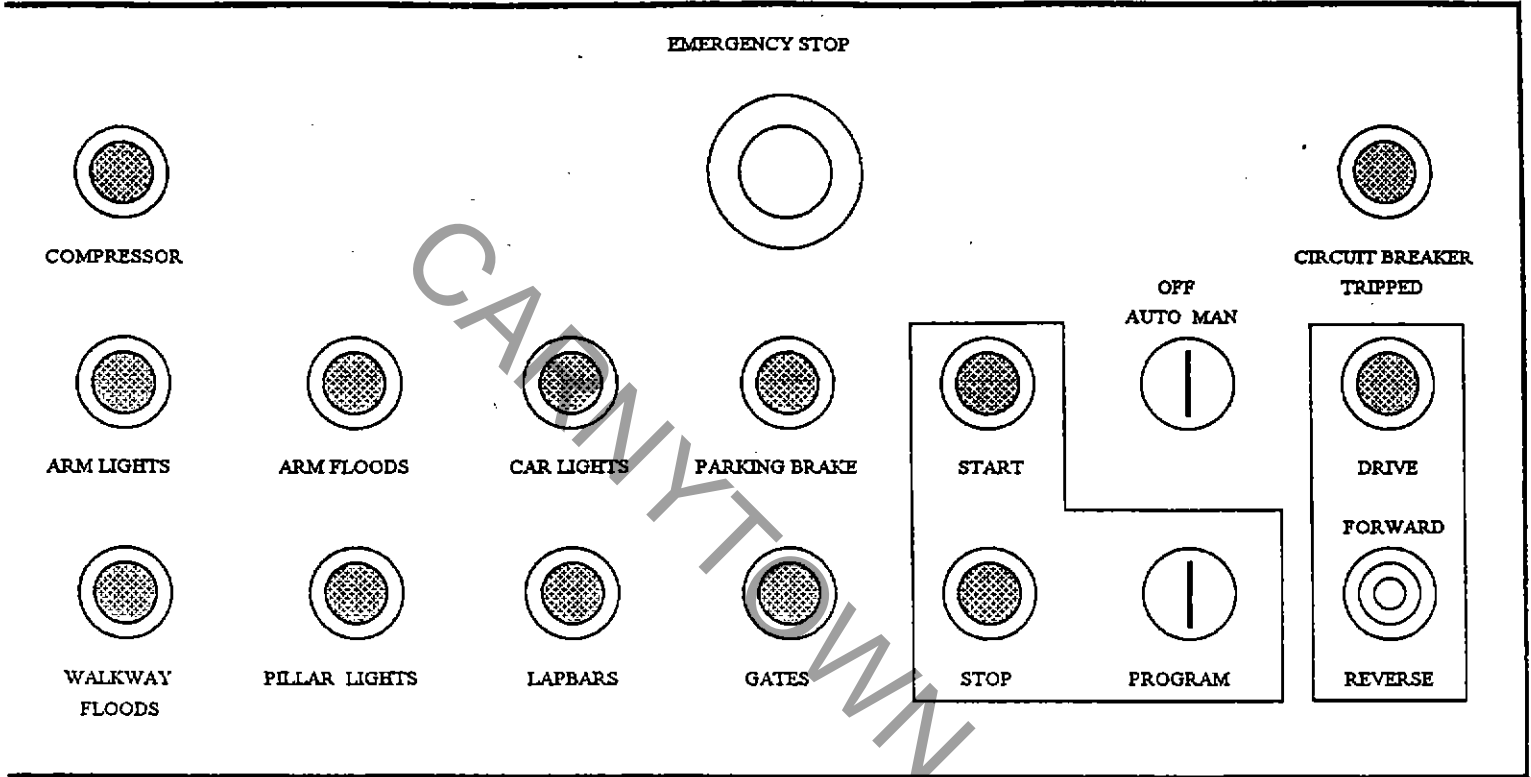

KEY

Push Switch With Light



Key Operated Switch



Joystick Control



Pre-Operational Check List

Before Start Up It Is The Operators Responsibility To Check The Following

- 1) Each passenger to be a **minimum** height of 1220 mm - 4'0".
- 2) Each car must contain a maximum of 22 passengers.
- 3) Each passenger is seated correctly and retained **securely** by lap bar.
- 4) Ensure by **physical check** that lap bars are securely **locked** in position.
- 5) Ensure no limbs are protruding outside the car.
- 6) Ensure there are no personnel in the vicinity of any moving parts of the machine.
- 7) Ensure ride is not operated if wind speed exceeds 65 kph (40 mph).

Note:-

If Wind Speed Exceeds 150 kph (90 mph) Then Depending On Site Conditions The Ride May Need Additional Anchorage To Prevent Sliding. If These Wind Speeds Are Anticipated Then Advice On Anchorage Must Be Sought From A Suitably Qualified Person.

Operation

- 1) Ensure passengers are secured in their seats and lap bars are locked, this must be ascertained by a physical check on each lap bar. Ensure there are no members of the public anywhere on the ride platform and that all warning lights are extinguished, push drive button to initiate the drive system then move joystick in direction of travel.
- 2) Repeat the joystick movement in the opposite direct to commence the initial swinging motion of the car, note that a full laden car will require approximately 10 swings before it goes over the top. Observe all passengers for any signs of acute distress or dangerous behaviour if this is apparent then stop the ride and if the passenger is in distress summon qualified help immediately.
- 3) When the car has gone over the top then hold the joystick in this position to maintain steady rotation. Continue to observe all passengers for distress or dangerous behaviour and stop the ride if necessary.
- 4) To stop the ride put the joystick in its central position which initiates the automatic stopping sequence.
- 5) When the ride is stationary switch off drive, then release the lap bars and gates to allow passengers to disembark. Ensure the passengers leave the ride in an orderly manner.

NORMAL OPERATIONAL SPEED 10 RPM

THIS MUST NOT BE EXCEEDED

Maximum Passenger Time Per Ride - 3 Min.

SECTION 5

INSPECTION AND MAINTENANCE PROCEDURE

CARNYTOWN.COM

Overview Of Inspection And Maintenance Procedure.

Due to the demanding environment suffered by amusement machines and the large number of duty cycles possible in a busy season it is felt prudent to err on the conservative side regarding inspection and maintenance procedure. This approach is felt to be justified in view of the fact that certain safety critical components cannot be duplicated to give a secondary backup system due to the specific type of motion or nature of the machine.

Mindful of the above and bearing public safety in mind an inspection procedure has been devised which accommodates all areas of a safety critical nature while maintaining a direct approach and minimising wasteful duplication.

The procedure relies on the operator for a day to day basic inspection routine he being the person ideally placed to spot any unusual events being intimately familiar with his particular ride and its idiosyncrasies.

It also allows the operator full involvement and the opportunity to carry out his duties under the H.S.E. code of safe practise at fairs.

The procedure is split into daily and weekly checklists which are the responsibility of the operator and his employees to carry out and three other procedures of a specialist nature.

These are a twelve monthly safety critical inspection, a twelve monthly general inspection and a two yearly N.D.T. inspection all carried out by an independent appointed person and carrying certification status.

The twelve monthly safety critical inspection is to incorporate the areas depicted in figures 1 to 6 inclusive which are included for the guidance of the inspecting body. These same areas are also to be included in the two yearly N.D.T. inspection.

Summary of inspection procedure.

- 1) Daily inspection and maintenance checklist. (by operator)
- 2) Weekly inspection and maintenance checklist. (by operator)
- 3) 12 monthly safety critical inspection. (for certification)
- 4) 12 monthly general inspection (for certification)
- 5) 24 monthly N.D.T. inspection (for certification)

On Completion Of Inspection Or Maintenance Procedure

Run The Machine Up To Full Operational Speed

Unladen And Check The Following.

- 1) Check all gauges and warning lights for correct function.
- 2) Check machine does not exceed max design speed.
- 3) Check for unfamiliar noises or vibration.
- 4) Check proper function and smoothness of controls.
- 5) Check proper function of safety devices or interlocks.
- 6) Check for any unusual movements, vibrations or deflections.
- 7) Check for any signs of overheating or smoke.
- 8) Check for any loose panels or covers.
- 9) Check the braking and stopping system at least twice in succession.
- 10) Check for any loose packing at all packing points.
- 11) Check any fire extinguishers are in position and correct type.

**Run the machine for at least 30 seconds in either direction
when carrying out the above checks.**

Daily Checklist.
(General)

- 1) Check platform area for any loose debris or grease/oil. Remove loose debris and cover any oil or grease with suitable absorbent granules.
- 2) Check platform steps for security and replace any missing 'R' clips, bolts etc. or repair if required.
- 3) Check all handrailing for security and replace 'R' clips, bolts etc. or repair if required. .
- 4) Check all perimeter fencing for security and replace any missing 'R' clips, bolts etc. or repair if required.
- 5) Check lap bars and locking mechanisms for security and lubrication, repair or lubricate if required.
- 6) Check counter-weight securing bolts for security and tighten if required.
- 7) Check car mounting securing bolts and tighten if required.
- 8) Check all flash panels are secure and 'R' clips in situ. Replace any missing 'R' clips, bolts etc. or repair if required.

Operational

- 9) Check lap bar operating mechanism and all system interlocks. If faulty, diagnose fault and repair.
- 10) Check ride operation and all system interlocks. If faulty, diagnose fault and repair.
- 11) Check lap bars will not open with ride operating. If faulty, diagnose fault and repair.
- 12) Check Emergency Stop operation. If faulty, diagnose fault and repair.
- 13) Check all braking systems function. If faulty, diagnose fault and repair.
- 14) Check all information and warning lights are operational. If faulty, diagnose fault and repair.

Note:- Do Not Operate Ride Before All Repairs And Adjustments Have Been Carried Out And Tested As Satisfactory.

DAILY

INSPECTION AND MAINTENANCE

CARNYTOWN.COM

Daily Checklist.
(General.)

Maintenance.

- 1) Lubricate car and main slewing ring drive teeth through hatch provided.
(Small amount of open gear lubricant.)
- 2) Lubricate car and main slewing ring at nipples provided.
(Small amount daily of G.P. grease. See lubricants list.)
- 3) Drain compressed air tank of accumulated water.
- 4) Check main electrical drive motor current level while operating and if outside normal operating parameters investigate locate fault and repair before operating ride.
- 5) Check all electrical trips are functioning correctly if not then investigate fault and repair before operating ride.

Note:- Do Not Operate Ride Before All Repairs And Adjustments Have Been Carried Out And Tested As Satisfactory.

Weekly Checklist.
(General)

- 1) Check slewing rings for wear and correct operation in the unloaded condition by rocking the car and main arm. If the movement present at the main arm exceeds the as new movement by 6mm (1/4") consult the ride manufacturer. If the car movement measured at the car ends exceeds the as new movement by 3mm (1/8") consult the ride manufacturer.
- 2) Check car, main slewing ring and fixed gear ring drive teeth for wear and bright spots. Pay particular attention to the tooth flank for any sign of flaking or undercutting. If there is evidence of flaking or undercutting then consult the ride manufacturer immediately.
- 3) Check drive pinion for wear and bright spots especially at the tooth tip, if present check backlash is in the range .22mm to .30mm (0.008") to (0.012") and ensure adequate lubrication at all times.
- 4) Check drive shaft universal joints for wear and cracks. If worn then replace universal joints with a ride manufacturers approved unit.
- 5) Check hydraulic motors for wear and noisy operation. If unserviceable then replace with a ride manufacturers approved unit.
- 6) Check hydraulic motors for leaks, replace any defective seals with overhaul kit or if unserviceable then replace with a ride manufacturers approved unit.
- 7) Deleted.
- 8) Deleted.
- 9) Check lap bar locking teeth for wear and defects. If teeth are badly worn or chipped then replace with a new factory unit.

WEEKLY

CARNYTOWN.COM

INSPECTION AND MAINTENANCE

Weekly Checklist
(General)

- 10) Check all lap bar weldments and bracketry for cracks if in doubt about condition have them inspected by a suitably qualified person and if unserviceable then replace with a new factory unit. If the unit is serviceable then consult the ride manufacture for a suitable repair procedure.
- 11) Check car mounting plate weldments for cracks paying special attention to mounting block weldments repeat this procedure for car mounting blocks positioned at rear of car. All weld cracks are to be reported to the ride manufacture for a suitable repair procedure.
- 12) Check car frame welds for cracks paying particular attention to the diagonal stays positioned at either end of car check weldments at both ends of stay. All weld cracks are to be reported to the ride manufacture for a suitable repair procedure.
- 13) Check car slewing ring mounting plate weldments all weld cracks are to be reported to the ride manufacture for a suitable repair procedure.
- 14) Check all flash panel hinge weldments for cracks, all weld cracks are to be reported to the ride manufacture for a suitable repair procedure.
- 15) Check main slewing ring/tower weldments for cracks, all weld cracks are to be reported to the ride manufacture for a suitable repair procedure.
- 16) Check tower base/chassis weldments for cracks, all weld cracks are to be reported to the ride manufacture for a suitable repair procedure.
- 17) Check stabiliser leg weldments for cracks, all weld cracks are to be reported to the ride manufacture for a suitable repair procedure.

Note:- Do Not Operate Ride Before All Repairs And Adjustments Have Been Carried Out And Tested As Satisfactory.

Weekly Checklist.
(General.)

Maintenance.

- 1) Check hydraulic oil level in main tank and replenish as required with the correct grade of hydraulic fluid.
- 2) Check hydraulic filters have spare capacity by ref to indicator gauge and change as required with the correct oil filter.
- 3) Check all main hydraulic hoses for leakage and fretting and replace as required with the correct grade of hoses or fitting.
- 4) Check all hydraulic operating pressures and correct circuit functions if in doubt about circuit function have checks and repairs carried out by a suitably qualified person.
- 5) Check car and main slewing ring drive gearbox oil level at filler/level plug.
(Top up with EP 90 oil to filler plug as required.)
- 6) Lubricate all driveshaft bearings with grease gun.
(Small amount weekly of G.P. grease. See lubricants list.)
- 7) Lubricate lap bar teeth and pawl by manually smearing teeth with grease.
(Small amount weekly of E.P. grease. See lubricants list.)
- 8) Check oil levels in the compressed air lubrication system visually.
(Top up with air lube oil as required.)
- 9) Check oil levels in the compressor by dipstick.
(Top up with SAE 40 diesel engine oil as required.)
- 10) Oil all panel hinges with SAE 30 oil by oil can or spray as required.
- 11) Oil all lap bar hinge points with SAE 30 oil by oil can or spray as required..
- 12) Oil counter weight hinges with SAE 30 oil by oil can or spray as required..
- 13) Check and maintain all hydraulic oil levels.

Note:- Do Not Operate Ride Before Maintenance And Adjustments Have Been Carried Out And Tested As Satisfactory.

Lubricant List.

<u>Manufacture</u>	<u>Type</u>	<u>Designation</u>	<u>Ambient Temperature</u> ⁰ C
ARAL	G.P.	Aralub HLP 2	-25 To 130
	E.P.	Arulub LFZ 1	-25 To 250
	G.P.	Energrease LS-EP 2	-25 To 130
BP	E.P.	Energol WRL	-0 To 80
	G.P.	Spheerol EPL 2	-20 To 120
Castrol	E.P.	Grippa 33 S	-20 To 80
	G.P.	Epexa 2	-30 To 120
ELF	E.P.	Cardrexa DC 1	-20 To 120
	G.P.	Beacon EP 2	-25 To 130
ESSO	E.P.	Surett Fluid 4K	-20 To 150
	G.P.	Cenoplex 2 EP	-20 To 120
Kluber	E.P.	Grafloscon CA 901	-20 To 150
	G.P.	Mobilux EP 2	-20 To 120
MOBIL	E.P.	Mobiltac 81	-30 To 120
	G.P.	Stabyl LEP 2	-20 To 120
REINER	E.P.	Ceplattyn KG 10	-30 To 250
	G.P.	Calithia EP Fett T 2	-25 To 130
SHELL	E.P.	Cardium Fluid C	-30 To 60
	G.P.	Multifak EP 2	-30 To 130
TEXACO	E.P.	Crater 2 X Fluid	-20 To 120

G.P. = General Purpose Grease i.e. pivot points etc.

E.P. = Extreme Pressure i.e. slewing ring gears etc.

ANNUAL SAFETY CRITICAL INSPECTION

N.D.T. PROCEDURE.

CARNYTTOWN.COM

Structural Examination
(Safety Critical)

- 1) Safety critical areas must be examined periodically by N.D.T .
- 2) The maximum time period between examination of these areas is not to exceed 1 year
- 3) The areas designated safety critical by the manufacturer are depicted on page 5.05
- 4) These safety critical areas are to undergo an N.D.T. inspection of parent metal in the direct vicinity of the joint weldment.

The joint weldment must also be given an N.D.T. inspection.

The inspection to examine the complete length of these joints.
- 5) The manufacture also recommends that bolts in the following areas are discarded at this time to accommodate bolt damage and inadvertent fatigue from incorrect bolt torque etc.

Designated areas requiring new bolts.

Counterweight hinge bolts
Tower base fixing bolts
Car to main arm fixing bolts

Note:-

In countries outside the United Kingdom where legislative requirements may differ and no clear seasonal pattern of operation exists then the annual safety critical inspection may be taken to mean the following.

1500 Site hours.

That is hours where the machine is erected on site and connected to a power supply available to do useful work.

600 Operating hours.

That is hours where the machine is erected on site and connected to a power supply and working to its full passenger capacity

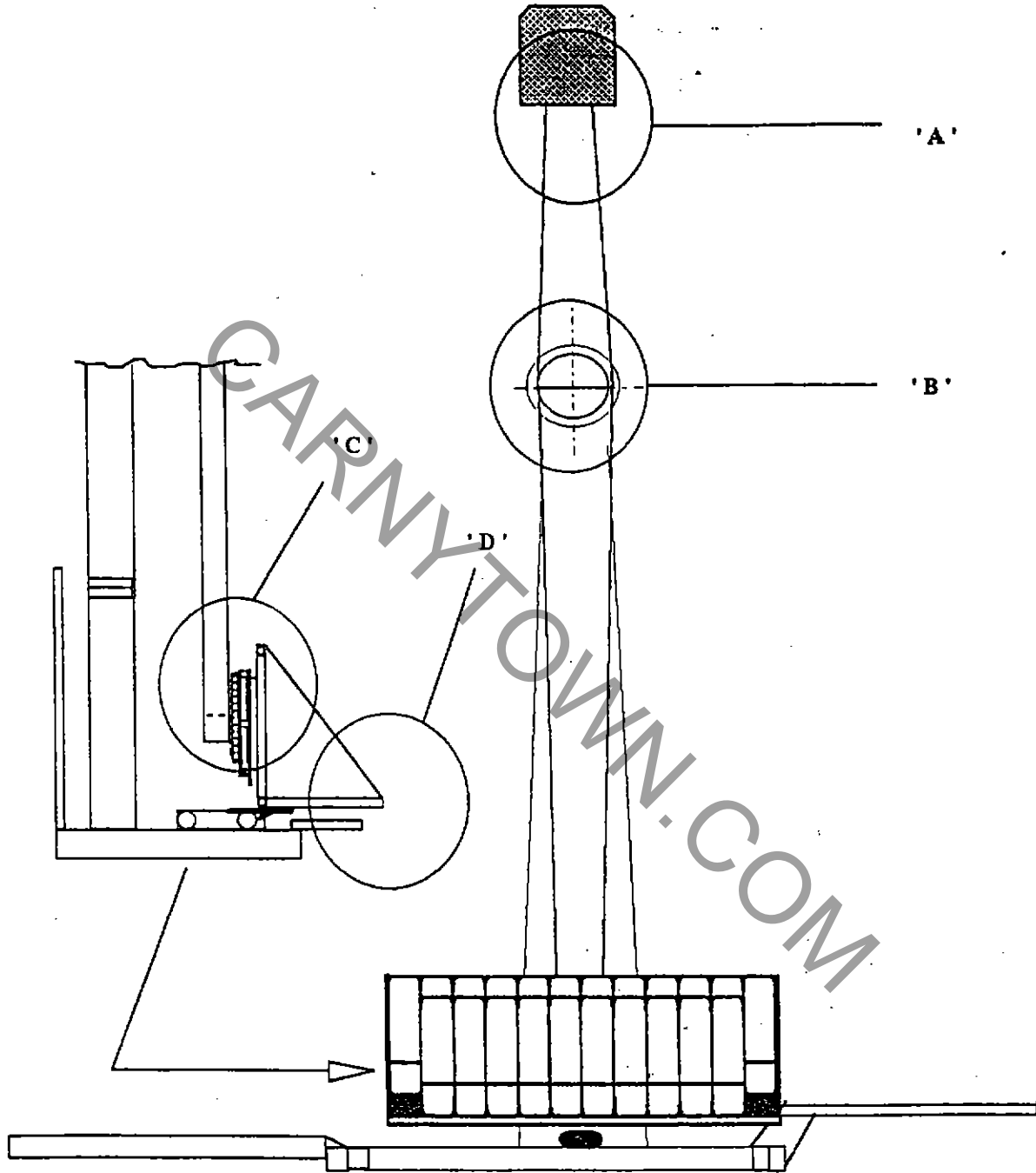

Side Elevation

Safety Critical Areas

- 'A')
 - i Counterweight to arm joint
 - ii Counterweight gussets to arm joint

- 'B')
 - i Counterweight arm to drive centre joint
 - ii Car arm to drive centre joint
 - iii Hinge gussets to drive centre and arm joint
 - iiii Tower top to main tower joint

- 'C'
 - i Slewing ring mounting plate to car lower arm joint
 - ii Car mounting plate assy
 - iii Car mounting bolt blocks joints

- 'D'
 - i Car framework joints
 - ii Car diagonal brace extreme end joints

SECTION SIX

ANNUAL / BI - ANNUAL INSPECTION

CARNYTTOWN.COM

Twelve Monthly Inspection And Maintenance.
(General)

Every twelve months the machine must undergo a thorough examination by an appointed person who is an independent examiner suitably qualified to undertake this task and preferably having experience of non-destructive testing (N.D.T.) on steel fabrications.

To aid this examination, all weldments not visible by virtue of being masked by other structures must be made visible and reasonable access provided by appropriate dismantling, in part, or whole, of the relevant sub-assemblies.

The following are the major areas of the machine to be examined using the appropriate procedure and working to the relevant checklist in a methodical manner.

Structural Examination

Mechanical Examination

Electrical Examination

Hydraulic Examination

Pneumatic Examination

Any defects found, to be noted, and the implications for the structural the machines safe operation to be noted. Any serious structural defects must be communicated to the manufacturer at the earliest opportunity so that suitable rectification methods may be formulated and any necessary design modifications may be incorporated in future machines.

If satisfactory, sign logbook and issue inspection certificate. If not, replace unsatisfactory members and test machine as relevant checklist.

Structural Examination.

- 1) Check all structures for gross deformation and signs of impact.
- 2) Check all connecting pins and bolts for deformation, cracks, surface fretting and correct material grade. If in doubt discard.
- 3) Check slewing ring securing bolts for defects and correct material grade. Must be grade 8.8.
- 4) Check structure for corrosion and cracking of parent metal or weldment especially in highly stressed regions in the vicinity of securing and retaining bolts or pins. If in doubt use N.D.T. such as dye penetrant test to corroborate findings.
- 5) Check deck plates for damage and cracks. If in doubt, discard.
- 6) Check any timber fabric for security and damp rot. If doubt, discard.
- 7) Check any superficial covers for security.
- 8) Check general level of upkeep and comment in writing.
- 9) Check general condition of paint finish and corrosion i.e. superficial or deep corrosion.
- 10) Check for general correctness of assembly, with particular attention to securing pins, i.e. positioned correctly or incorrectly.
- 11) Check bolts for correct torque and grade, i.e. grade 8.8.

Note.

Prior to examination of 1 to 3 inclusive, degrease and clean thoroughly.

Prior to examination of 1 to 4 inclusive, remove any paint or corrosion and clean thoroughly.

Mechanical Examination

- 1) Check slewing ring for roughness in operation, also check for play between races.
- 2) Check slewing rings for adequate greasing and any corrosion.
- 3) Check slewing ring drive gears for pitting, flaking and backlash.
- 4) Check slewing ring bolts for correct grade and torque.
- 5) Check drive motor pinion for lubrication and corrosion.
- 6) Check drive motor pinion for pitting, flaking, corrosion and correct backlash.
- 7) Check all bearings for lubrication and corrosion.
- 8) Check all bearings for pitting and movement between races.
- 9) Check all bolted connections for correct torque and grade.
- 10) Check all friction drives for wear, splits and resident material.
- 11) Check all drive shafts for straightness, cracks and corrosion.
- 12) Check all stabiliser legs for correct operation and security.
- 13) Check all passenger restraint devices for lubrication and corrosion.
- 14) Check all passenger restraint devices for wear and operation.
- 15) Check all passenger restraint devices locking mechanism for security and correct operation. Check any back up systems and interlocks for security and operation.
- 16) Check all 'R' clips or securing pins for correct material specification and damage. If in doubt discard.
- 17) Check all bolts used for erection purposes for correct material grade, thread damage and straightness. If in doubt discard.

Electrical Examination - 240 Volt And 415 Volt A.C.

- 1) Check all generator terminals. Single or three phase are enclosed.
- 2) Check all sockets and connectors are of industrial type L.E. BS.4343.
- 3) Check that all neutral of conductors are connected to the metal enclosure of all the equipment and where possible and are connected to an earth electrode via a protective conductor. The connection to earth should be made at one point i.e. the generator.
- 4) Check no switches are inserted in any protective conductor and no single pole switch inserted in any neutral conductor.
- 5) Check if a rotary inventor is used to produce AC from DC. Earthing requires special consideration.
- 6) Check residual current circuit breakers for max setting of 30 m.a.
- 7) Check residual current circuit breakers are installed in the conductors between earth reference point and the distribution equipment.
- 8) Check all metallic parts of the ride carrying electrical equipment should be bonded and connected to the protective conductors.
- 9) Check where the ride is on hard standing it may not be possible to earth. It is imperative that protective bonding is checked regularly.
- 10) Check all cables are flexible multi-core with correct rating.
- 11) Check any flexible armoring is connected to system protective ductors.
- 12) Check all cable joints and terminations are mechanically protected and provided with the appropriate strain relief.
- 13) Check that any 13 amp domestic fitting is weatherproofed and properly supported.
- 14) Check that all motor starters are provided with overload and short-circuit protection and where restarting after power loss may cause danger ensure the starter is fitted with a device which opens the starter switch on loss of power.

- 15) Check all A.C. motors are fully enclosed.
- 16) Check that where 3 phase supplies are used for lighting the separate phases are at least 2 metres apart and clearly identified.
- 17) Check all fuses and circuit breakers are correctly rated.
- 18) Check all cables, couplers or plugs and sockets are connected so that live pins cannot be exposed.
- 19) Check neon lights are inaccessible and the transformer and cables are out of reach and weatherproofed.
- 20) Check that if A.C. and D.C. lighting is used, plugs and sockets are not to be cable or cross connected.
- 21) Check all parts of the system for earth leakage and remedy faults.
- 22) Check continuity of protective conductors. Max voltage 50 volts max current 25 amps. Check the measured value of resistance low enough to protect the system by removal of the supply in the event of a short circuit to metal parts.
- 23) Check insulation resistance. Max test voltage 500 V D.C. The measured resistance to be not less than 1 megohm. Ensure test voltage is not applied across electronic components that may be damaged.
- 24) Check residual circuit breakers with suitable RCCB instrument. They should trip to the rated current. Also check the test button to ensure tripping mechanism is free.
- 25) Check all electrical enclosures are properly secured to prevent unauthorised access. Check where such enclosures are accessible to the public, they should be fitted with lockable handles so a tool is necessary to gain access.
- 26) Check interlocking control systems with wiring diagram to ensure system integrity is maintained after any modifications. The devices should be examined for mechanical wear and deterioration of insulation resistance between conductors and also checked for correct operation.

Electrical Examination - 110 Volts D.C.

- 1) Check generator output is not connected to earth.
- 2) Check there is a generator isolator switch in each pole.
- 3) Check for correct fuses on output panel, one per pole.
- 4) Check isolators and fuses are not shorted out by wire links.
- 5) Check terminal connectors are brass and not ferrous.
- 6) Check all exposed live points have covers of robust insulating material.
- 7) Check all metal enclosures are connected by low resistance bonding conductors, including the generator frame.
- 8) Check cables are flexible with tough outer cover, not metal armored.
- 9) Check all cables are protected from mechanical damage by conduit etc.
- 10) Check all cables on output panel are restrained to prevent strain on terminations.
- 11) Check if ride is on hardstanding, cables to be clear of main thoroughfare.
- 12) Check all joints to make good electrical contact and to be of adequate mechanical strength and properly insulated. Twisted wire joints are not acceptable.
- 13) Check joints for signs of overheating and high resistance.

- 14) Check all motor starting systems incorporate a no-volt device to ensure that if supply fails it reverts to off position.
- 15) Check the resistance elements enclosure is adequately ventilated and robust.
- 16) Check all cable terminations, starters and motors are shrouded with robust covers.
- 17) Check all terminations under rides are shrouded and enclosed.
- 18) Check fuses are fitted in each pole at the starter to protect from overloads.
- 19) Check lighting circuits are fused against overloads.
- 20) Check flashing light contactor panels are enclosed.
- 21) Check all D.C. conductors and cables for faults to earth are correct.
- 22) Check continuity of bonding conductors. Test volts max 50 current not exceeding 25 amps. Resistance of conductors 0.5 ohms max.
- 23) Check the insulation resistance of equipment. Max test voltage 500 min resistance not less than 0.5 megohms.

Hydraulic Examination.

- 1) Check hydraulic pump for smooth operation with no signs of cavitation, noise or leakage.
- 2) Check shaft drive coupling for wear and security (if not close coupled).
- 3) Check for hoses or fittings leaking and kinked or damaged pipes.
- 4) Check any indicators on oil filters (where provided) for evidence of sludging.
- 5) Check oil filler cap is not sludged and tank is open to atmospheric pressure.
- 6) Check oil is not heavily contaminated, sludged or carburised.
- 7) Check any bundy tubing is not pitted or corroded.
- 8) Check drive motor for jerky running or loss of power (leakage).
- 10) Check settings of any relief or cross over relief valves.
- 11) Listen for squealing noises from valves.
- 12) Check control linkage for smooth consistent operation.

Pneumatic Examination

- 1) Check for leaks in cylinders or pipework.
- 2) Check cylinder stems for pitting or corrosion.
- 3) Check cylinders for retention of fluid.
- 4) Check main filter for sludge and water retention.
- 5) Check cylinders for jerky or intermittent operation.
- 6) Check cylinders for bent rods.
- 7) Check main reservoir for leaks and retention of water.
- 8) Check all valves for function, especially the exhaust section.
- 9) Check pressure is within design specification.

Test Procedure.

- 1) Request all parts found defective are replaced.
- 2) When satisfied that the ride is erected in the correct manner, request that the ride is operated unladen to its maximum design speed.
- 3) Observe ride in unladen operating condition.
- 4) If satisfied, request that the ride be loaded to its maximum design specification .
- 5) Request that the ride be operated to its maximum design speed .
- 6) Observe the ride in fully laden operating condition.
- 7) Request that the ride is unloaded and re-examine as in :-

Structural check list :- 1 - 11

Mechanical Check list :- 1 - 17

Hydraulic check list :- 1 - 12

- 8) If satisfactory, issue certificate and sign logbook.
- 9) If the second examination reveals defects, downrate the ride and repeat examination. The nature of the defects should be communicated to the manufacturer for their dissemination and appraisal .

BI - ANNUAL

GENERAL N.D.T. INSPECTION.

CARNYTOWN.COM

Two Yearly Inspection (N.D.T.)

Every two years the machine should be submitted to non - destructive testing (N.D.T.) of its structural components.

This should be carried out by an appointed person who is an independent examiner (as in the annual inspection) and an N.D.T. technician certified to appropriate in a nationally recognised certification scheme, viz :-

- 1) PCN - (Personal Certification In N.DT.)
- 2) ASNT - (American Society Of N.D.T.)

Appropriate level for evaluation of results is level 2. It is the responsibility of the appointed person to verify the technician is suitably qualified and agree the test method and technique to be used.

The appointed person must distinguish between original manufacturing flaws and ones developed during use. Also he must distinguish between significant and insignificant flaws.

It is advised that the appointed person consults expert opinion as appropriate in the following disciplines :-

- 1) N.D.T.
- 2) Stress Analysis.
- 3) Welding Technology.

See checklist for N.D.T. of machine structure.

N.D.T. Inspection.

Recommended Methods Of N.D.T.

- 1) Dye Penetrant Test DPT For surface cracks.
- 2) Magnetic Particle Test MT For surface cracks.
- 3) Ultrasonic Testing UT For flaws and thickness.

Applications checklist.

- 1) Check for surface cracks in parent metal at weld toes, edges of holes and any flamecut edges, in general terms in the vicinity of any stress raisers.
- 2) Check for cracks in the surface of weldments. These should appear along the throats of weldments.
- 3) Check for cracks in drive shafts in the vicinity of keyways, holes, changes in diameter or any other geometrical discontinuity.
- 4) Check for reduction in wall thickness in hollow sections caused by internal corrosion, also check for serious external corrosion (this is less likely). This is important on thin walled hollow sections in the vicinity of weldments and high stress areas.

Note:-

Use DPT/MT for 1 to 3 after thorough surface preparation and degreasing of structural surface.

Use UT for 1 to 4 . Remove paint and thoroughly clean, coat with grease to give a good acoustic coupling.

On completion of testing, re- paint all surfaces.

Specific Areas To Be Checked

- 1) Check main arm joint weldment (At mid position).
- 2) Check main arm to centre weldment.
- 3) Check car mounting blocks and car frame weldments.
- 4) Check tower bolt blocks weldment.
- 5) Check tower to trailer weldment.
- 6) Check car slewing ring mounting plate to main arm weldment.

Note : These Are All Areas Of Maximum Stress

Other areas to be checked are at the discretion of the appointed person.
Machine to be dismantled as in annual inspection to allow sufficient access for the N.D.T. technician and equipment.

The Following Information Is Required On N.D.T. Report

- 1) Date of examination.
- 2) Technicians name and qualification.
- 3) Details of N.D.T. technique.
- 4) Parts examined and which elements comprised part of sample.
- 5) Parts unavailable for examination, if any.
- 6) Results of examination.

All Reports To Be Kept Available By The Ride Owner

Hydraulic Circuit.

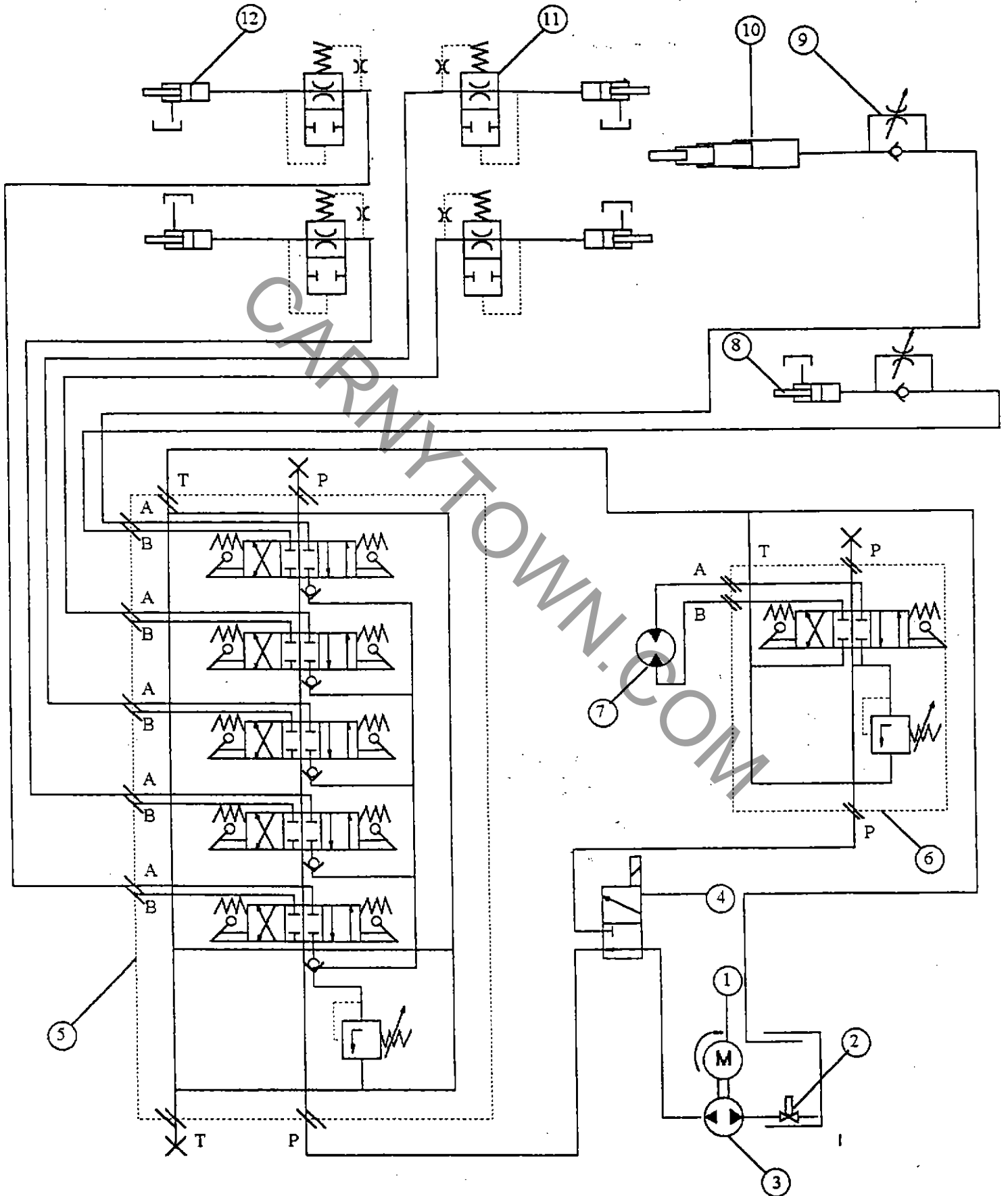

Hydraulic Circuit.

- 1) Three phase motor
- 2) Isolating valve
- 3) External gear pump
- 4) Manual two way valve
- 5) 5 Stack manual spool valve
- 6) Manual spool valve
- 7) Hydraulic motor on winch
- 8) Pusher ram (Tower)
- 9) Flow control valve
- 10) Main lift ram (Tower)
- 11) Velocity fuse
- 12) Levelling rams (Trailer)

ALI BABA FINAL INSPECTION AND CHECKLIST

RIDE NO. AB 37

DATE OF TEST 2/10/97

Pre-Operational Check List

- 1 Check all Outriggers and Support Jacks are correctly positioned
- 2 Check Tower Joint Bolts for security
- 3 Check Counterweight Bolts for security
- 4 Check Car to Main Arm Bolts for security
- 5 Check all Flash Panel are secure
- 6 Check all Steps and Platforms for security
- 7 Check all Perimeter Fencing for security
- 8 Check all Perimeter Fencing for Burrs
- 9 Check Interior and Exterior of Cars for sharp edges/burrs
- 10 Check all Lap Bar operating mechanisms for correct operation and adjustment.

Operation Check List - Ride Unloaded

- 1 Operate ride in Manual mode and check for any adverse vibrations, noises, or unusual conditions.
- 2 Test Emergency stop operation and record duration to standstill.
Time 1 x 41 SEC
- 3 Passenger Evacuation in Event of Power Failure - check manual unlocking operation of Car Gates and Passenger Restraint Bars
- 4 Check that Restraint Bars and Car Gates can not be opened whilst ride is in motion (i.e. with passenger on board swing ride gently and press restraint bar and car gate opening switches).
- 5 Record duration to stop using operational stop button (not emergency stop button).
Time 22 SEC
- 6 Record Maximum speed of ride.
Speed 8 R.P.M.
- 7 Check Automatic Cycles Function correctly.
Cycle 1
Cycle 2
Cycle 3
- 8 Check Controlled stop Function Correctly in each Automatic Cycle.
Cycle 1
Cycle 2
Cycle 3

Operation Check List - Fully Loaded

N/A

- 1 Operate ride in Manual mode and check for any adverse vibrations, noises, or unusual conditions.
- 2 Record Duration to Standstill of Controlled Stop. Time
- 3 Record Duration to Standstill of Emergency Stop. Time
- 4 Record Ride Maximum Speed. Speed R.P.M.

Checklist Completed By:

SIGNED:

[Signature]

NAME:

S. STOKES

DATE:

02/10/97