

MFG: A.R.M. (UK) LTD.
NAME: SKYMASTER
TYPE: NON-KIDDIE

OPERATION AND MAINTENANCE MANUAL

'SKYMASTER'

MANUFACTURER : A.R.M.

I N D E X

SECTION 1	TYPE DESIGNATION
SECTION 2	DESIGN SPECIFICATION
SECTION 3	ERECTION AT SITE
SECTION 4	OPERATIONAL PROCEDURES
SECTION 5	TESTING AND INSPECTION
SECTION 6	MAINTENANCE
SECTION 7	SERVICE BULLETIN

T Y P E D E S I G N A T I O N

T Y P E D E S I G N A T I O N

'SKYMASTER'

S E R I A L N O :

M O N T H O F M A N U F A C T U R E

Y E A R O F M A N U F A C T U R E

M A N U F A C T U R E R

A . R . M . (U K) L I M I T E D

A D D R E S S

E N S T O N E

O X F O R D S H I R E

E N G L A N D .

SECTION 2

DESIGN SPECIFICATION

CARNYTOWN.COM

		<u>MM</u>	<u>INS</u>
Max Length	Travelling	14,630	576
Max Length	Erected	16,385	645
Max Width	Travelling	2,590	102
Max Height	Travelling	4,111	161
Max Overall Width	Erected	7,500	295
Max Height swept by car	Erected	18,300	720
Max Height top of machine	Erected	10,165	400
Max Height of decking	Erected	1,400	55
Max width of seating (internal)	Erected	940	37
Max car length front to back (int)	Erected	7,700	303
Min clearance to any adjacent ride	Erected	1,000	39
Max weight gross	Travelling	29,000 Kg	63,800 Lbs.
Max no. of passengers per car	Erected		16
Max passenger weight per car	Erected	1,235 Kg	2,720 Lbs
Max passenger weight total	Erected	2,470 Kg	5,440 Lbs
Max loaded weight of machine	Erected	31,470 Kg	69,240 Lbs
Max design rotation speed of centre	Erected		12 rpm
Direction of rotation centre	Erected		Clock or Anti-Clock
Max loading on footings	Static/Dynamic	10,000Kg	22,020Lbs

Max force on passengers outwards from centre @ B.D.C.	2.27G
Max linear velocity of passengers @ max radius	30 mph
Max recommended passenger time per ride	3.0 min
Min recommended passenger height	48" - 1220 mm
Max imbalance distribution when half empty	50%
Max overturning moment @ max imbalance Longitudinally	675 Ton Ins
Min restoring moment available	3716 Ton Ins
Max horizontal force @ max imbalance and max load	4032 Lbs
Min coefficient of adhesion required unladen	0.18
Min available on hardstand steel on concrete	0.30
Min factor of safety @ max imbalance and load tipping	5.5:1
Min factor of safety @ max imbalance and load sliding	2:1
Max recommended deviation from horizontal when erected	+/- 2.5°
Max drive motor torque @ max passenger load	210 Lb Ft.
Max mechanical power @ max passenger load	72 H.P.

Min static F.O.S. (on yield) fully loaded of any structure	3:1
Min static F.O.S. (on ultimate shear stress)	10:1

STANDARDS COMPLIED WITH OR EXCEEDED

Structural standards		BS5400-10	
		BS449	
Material Specification -	Plate	Minimum	BS4360-G43A
	Hollow	Minimum	BS4360-G43C
	Bright Bar	Minimum	EN8

Health and Safety Executive Code of Practice (Current draft copy)

Health and Safety Executive Code of Practice 1984

ASTM Amusement Rides and Devices 1987

	<u>YIELD</u>	<u>UTS</u>
All Plate and Rolled Sections	16.0 Ton/In ²	28.0 Ton/In ²
All Hollow Sections	16.0 Ton/In ²	28.0 Ton/In ²
All Bright Bar and Fixing Pins	18.0 Ton/In ²	35.0 Ton/In ²
All Imperial Sized Bolts - UNF	34.0 Ton/In ²	50.0 Ton/In ²
All Metric sized bolts - 150 coarse G.8.8.	34.0 Ton/In ²	50.0 Ton/In ²

MAX BOLT TORQUES @ 80% YIELD

3/8" UNF	4.8 Kg m	35 Lb ft.
1/2" UNF	11.7 Kg m	85 Lb ft.
5/8" UNF	23.5 KG m	170 Lb ft.
3/4" UNF	41.5 Kg m	300 Lb ft.
1" UNF	101.0 Kg m	730 Lb ft.
M10	5.9 Kg m	43 Lb ft.
M12	10.3 Kg m	75 Lb ft.
M16	25.6 Kg m	18.5 Lb ft.
M20	50.1 Kg m	362 Lb ft.
Main Tower Bolt Torque (M30)	65.0 Kg m	450 Lb ft.
Car to Arm Bolt Torque (M39)	50.0 Kg m	350 Lb ft.
Counterweight Bolt Torque (M30)	65.0 Kg m	450 Lb ft.

Bolt, Torques to be re-checked after running ride empty for 3 minutes.

This allows for bedding in of threads and washers etc.

SECTION 3

ERECTION AT SITE

CARNYTOWN.COM

CARNYTOWN.COM

FLOOR

- 1) Check site for flatness.
- 2) Position trailer.
- 3) Connect to power supply.
- 4) Put down 4 levelling jacks and level trailer.
(Do not deflate air suspension at this time).
- 5) Adjust 2 screw jacks on rear of trailer.
- 6) Pull out 4 stabilising outriggers and adjust.
- 7) Deflate air suspension (do not remove rear screw jacks until suspension is inflated).
- 8) Fit winch pulley frame to top of tower base.
- 9) Fit winch hook to bracket on inside of floor (one side only).
- 10) Fold down hinged apron and pin in position (one side only).
- 11) Fold out bowstrings (one side only).
- 12) Remove securing pins and attachments on floor (one side only).
- 13) Lower floor (on winch) and fit adjustable feet.
- 14) Repeat procedure 9 to 13 on other side.
- 15) Unfold front section of floor.
- 16) Unfold rear section of floor.
- 17) Level up with adjustable feet.

NOTE

TO PREVENT POSSIBLE INJURY

DO NOT STAND IN THE VICINITY OF FLOORS BEFORE OR DURING THE LOWERING PROCEDURE

COUNTERWEIGHT ARM

- 1) Remove securing pin.
- 2) Unfold counterweight arm.
- 3) Ensure light panel misses control box while unfolding.
- 4) Fold up hinged light panel and pin in position.
- 5) Repeat on other side.
- 6) Fit arm securing bolts.
- 7) Tighten to 65 Kg m - 450 Lb ft.
- 8) Fit safety shear pin and 'R' clip.
- 9) Fold up light panels on main arm and pin.
- 10) Take light panels from front rack and fit to main arm centre and side.
- 11) Make all electrical connections both sides.
- 12) Fit pillar lights and spot lights around floor area. Take from front stack.
- 13) Fit guard rails all round, take from front rack.
- 14) Make all electrical connections.

CARS

- 1) Ensure safety chain is attached to car and tower.
- 2) Fit hinged doors and gas struts to outer face of car.
- 3) Attach extension roller angles.
- 4) Release car from side of tower (by removing transit bolt and nut) and roll outward to stop on angle runners.
- 5) Lower with hydraulic jack to lever mounting position.
Repeat with second car.

TOWER

- 1) Before elevating tower ensure small hydraulic cylinder is full by operating down lever for 5 seconds.
- 2) Elevate Tower via control lever.
- 3) Position cars accurately under main arm flanges.
- 4) When Tower is vertical fit securing bolts at top of base and tighten to 65 Kg m - 450 Lb. ft.
- 5) Fit bolts to car and main arm flange, tighten to 50 Kg m - 350 Lb. ft.
- 6) Fit tie bars between main arm and car. Fit 'R' clips to tie bar pins.
- 7) Connect air and power supply.
- 8) Remove safety chain from car.
- 9) Fit safety bars on inside face of car.
- 10) Remove roller angle extensions.
- 11) Lift up passenger access ramps in floor and fit front wedges.

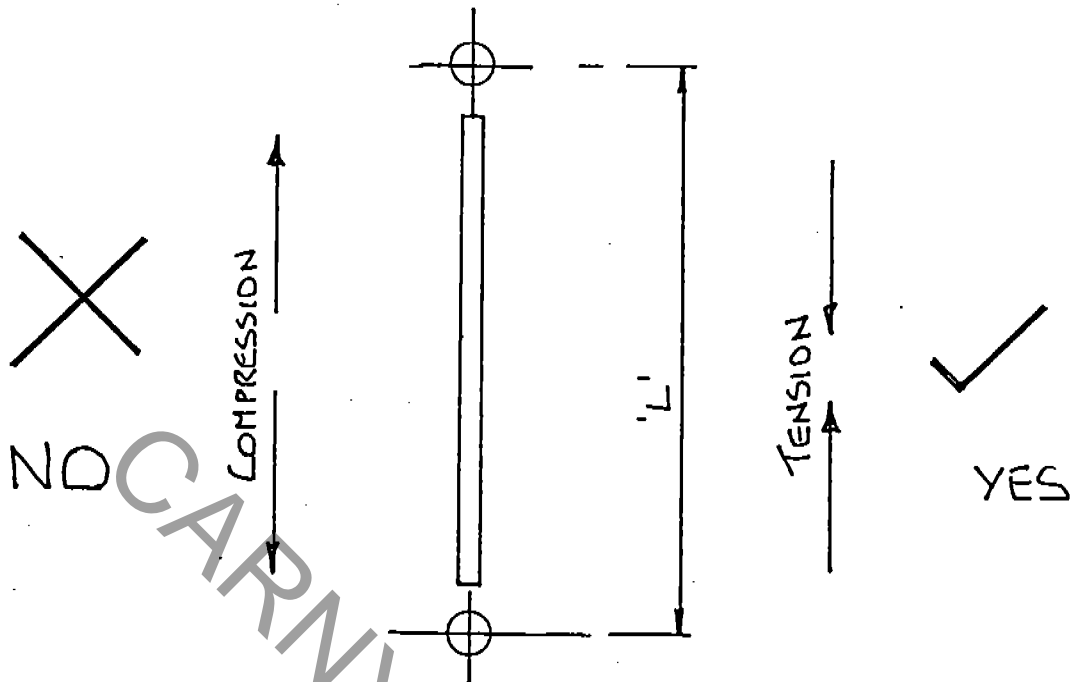

IMPORTANT

- 1) With ride stationary, both cars at bottom dead centre and empty of passengers, adjust tie rods as below.
- 2) Adjust tie bar centres 'L' so that fixing pins may be inserted through tie bar/brackets. Fit 'R' clips.

NOTE : Ends of tie bar have left hand and right hand threads.

- 3) Grasping hand grip bars at base of tie bar rotate bar 10° in the direction that reduces tie bar centres 'L'.

NOTE : Rod must go into tension not compression.

- 4) This must be performed BY HAND ONLY do not use mechanical means.
Maximum force on hand grip 15 Kg - 35 Lbs.

CARNYTOWN.COM

CARNY TOWN.COM

SECTION 4

OPERATION AND CONTROLS

CARNYTOWN.COM

THE CONTROLS OF THE 'SKYMASTER'

COMPRISE THE FOLLOWING

<u>SWITCHES</u>	<u>ON LIGHT</u>	<u>TRIP LIGHT</u>
Compressor		
Floodlights Arm	"	"
Floodlights Walkway	"	"
Lights Arm	"	"
Lights Main Pillar	"	"
Lights Car	"	"
Hydraulic Pump	"	"
Mentor Drive System	"	
Air Brakes	"	
Motor Blowers		"
Main Outlets		"
Zero Speed	Light	
Lap Bar Release/Lock	Open Light	
Car Gates Open/Close	Open Light	
Emergency Stop Button		
Main Control Joystick	Forward/Reverse	

PRE-OPERATIONAL CHECK LIST

BEFORE START UP IT IS THE OPERATORS RESPONSIBILITY TO CHECK THE FOLLOWING:

- 1) Each passenger to be a minimum height of 1220 mm - 4'-0".
- 2) Each car must contain a maximum of 16 passengers.
- 3) Each passenger is seated correctly and retained securely by lap bar.
- 4) Ensure by physical check that lap bars and side gate are securely locked in position.
- 5) Ensure no limbs are protruding outside the car.
- 6) Ensure there are no personnel in the vicinity of any moving parts of the machine.
- 7) Ensure both tie bars are in position and secured.
- 8) Ensure ride is not operated if wind speed exceeds 40 mph - 65 kmh.

N O T E

IF WIND SPEED EXCEEDS 80 MPH - 130 KMH THEN RIDE MAY NEED ADDITIONAL ANCHORAGE TO PREVENT SLIDING

ANCHORAGE REQUIREMENT IS DEPENDANT ON THE TYPE OF STANDING

HARDSTANDING SUCH AS CONCRETE MAY REQUIRE ANCHORAGE

SOFT STANDING SUCH AS GRASS WILL NOT REQUIRE ANCHORAGE

O P E R A T I O N

- 1) To operate machine release air parking brakes and move joystick in direction of travel.
- 2) Repeat in opposite direction to initiate the initial swinging motion of car.
- 3) A fully laden car will require approximately 10 swings before it goes over the top.
- 4) When car has gone over the top then hold joystick in position to maintain steady rotation.
- 5) To stop ride put joystick in central position which initiates automatic stopping sequence.
- 6) When ride is stationary put on air brakes to hold car in position while passengers disembark.

N O R M A L O P E R A T I O N A L S P E E D 1 2 R P M

THIS MUST NOT BE EXCEEDED

MAXIMUM RECOMMENDED PASSENGER TIME PER RIDE 3 MIN

CARNYTOWN.COM

CARNY TOWN.COM

SECTION 5

INSPECTION

CARNYTOWN.COM

TRAILER

1. Check any timber shoring under trailer for security.
2. Check surrounding area for local subsidence.
3. Check machine is true and level.
4. Check any hydraulic jacks, securing pins and fastenings.
5. Check any hydraulic hoses and fittings.

DECKING

1. Check full circumference of perimeter fence for security.
2. Check steps at entrance points for security.
3. Check all deck plates for loose screws and protrusions.
4. Check for any loose debris or grease.
5. Check there are no obstructions in front of control booth door.

CARNYTOWN.COM

DAILY INSPECTION

AND MAINTENANCE

MACHINE

SECURING PINS, 'R' CLIPS AND NUTS AND BOLTS

1. Check car securing bolts and 'R' clips.
2. Check slewing ring/Tower bolts for security.
3. Check all passenger restraining bars for proper function.
4. Check Electrical drive motor bolts for security.
5. Check all drive Gear Boxes securing bolts for security.
6. Check main Tower securing bolts for security.

FABRIC AND WELDMENTS

1. Check all structures for major distortion, bucking etc.
2. Check all cars fabric for cracks or damage.
3. Check all wiring and light fittings for security.
4. Check all structures for cracks in parent metal at critical points.
5. Check all structures for cracks in weldments at critical points.

DRIVE SYSTEM

1. Check drive shafts for cracks and security.
2. Check drive shaft bearings for operation.
3. Check all power cables and contactors for damage and operation.

LUBRICATION

1. Check all hydraulic fluid levels.
2. Check all securing/pivotal pins are greased.
3. Check all bearings for adequate lubrications, (including slewing ring).

RUN MACHINE UP TO FULL OPERATIONAL
SPEED (UNLADEN) AND CHECK

1. All gauges and warnings lights for correct function.
2. Machine does not exceed max operation speed (12 rpm).
3. For unfamiliar noises or vibrations.
4. Proper function and smoothness of controls.
5. Proper function of any safety devices or interlocks.
6. Any unusual movements or deflections of machine.
7. Any signs of overheating or smoke.
8. For any loose cover panels or fittings about to detach from machine.
9. Braking/stopping system of machine at least twice in succession.
10. Any fire extinguishers are in position and correct type.

CARVYTOWN.COM

WEEKLY INSPECTION

AND MAINTENANCE

CARNYTOWN.COM

TRAILER

1. Check main structural members and weldments for cracks.
2. Check any hydraulic jacks for corrosion of chromed stem.
3. Check any hydraulic jacks for seepage of fluid.
4. Check any hydraulic hoses and fittings for seepage or damage.

DECKING

1. Check perimeter fence for damage and security.
2. Check all aluminium chequer plate decking for damage and security.
3. Check for metal/weldment cracks at tower/trailer connection.

MACHINE

SECURING PINS, 'R' CLIPS AND BOLTS

1. Remove tie bar securing pins and check as (4).
2. Remove car retaining pins and check as (4).
3. Remove car/arm retaining bolts and check as (4).
4. From 1 to 4 inclusive, check for any signs of the following - surface indentation, fretting, (bright spots), cracking, deformation and corrosion.

CHECK THE FOLLOWING BOLT TORQUES

WITH A RELIABLE TORQUE WRENCH

5. Slewing ring/tower.
6. Electrical drive motor securing bolts.
7. All drive shaft securing bolts.
8. All drive shaft bearing blocks securing bolts.

FABRIC AND WELDMENTS

1. Examine one complete structure of each type for cracks in the vicinity of weldments and including the actual weldments. The structures to be examined in sequence, i.e. Arm L.H. Week 1. Arm R.H. Week 2. Car L.H. Week 1. Car R.H. Week 2. etc.,
2. Check paint work and make good if required.

DRIVE SYSTEM

1. Check drive shafts for wear, in universal joints and splines.
2. Check drive shaft bearings for wear and tight spots.
3. Check slewing ring for wear by rocking.
4. Check slewing ring for tight spots.

LUBRICATION

1. Check hydraulic fluid for carburisation and contamination.
2. Check hydraulic filters for proper function and silting.
3. Grease slewing ring at grease nipples provided.
4. Grease drive shaft bearings at nipples provided.

LAP BARS

1. Check toothed quadrant for wear and damage
2. Check pawl tip for wear and damage, max tip width not to exceed 1.5mm
3. Lubricate teeth & pawl with general grease
4. Lubricate pivotal points with SAE 30 oil

OPERATE MACHINE AND CHECK AS IN DAILY INSPECTION

TWELVE MONTHLY INSPECTION AND MAINTENANCE

(GENERAL)

Every twelve months the machine must undergo a thorough examination by an appointed person who is an independent examiner suitably qualified to undertake this task and preferably having experience of non-destructive testing (N.D.T) on steel fabrications.

To aid this examination, all weldments not visible by virtue of being masked by other structures must be made visible and reasonable access provided by appropriate dismantling, in part, or whole, of the relevant sub-assemblies.

The following are the major areas of the machine to be examined using the appropriate procedures and working to the relevant checklist in a methodical manner.

Structural Examination Safety Critical

Structural Examination General

Mechanical Examination

Electrical Examination

Hydraulic Examination

Pneumatic Examination

Test Procedure Examination

Any defects found, to be noted, and the implications for the integrity of the machines safe operation to be noted. Any serious structural defects must be communicated to the manufacturer at the earliest opportunity so that suitable rectification methods may be formulated and any necessary design modifications may be incorporated in future machines.

If satisfactory, sign logbook and issue inspection certificate. If not, replace unsatisfactory members and test machine as relevant checklist.

STRUCTURAL EXAMINATION

(GENERAL)

1. Check all structures for gross deformation and signs of impact.
2. Check all connecting pins and bolts for deformation, cracks, surface fretting and correct material grade. If in doubt discard.
3. Check slewing ring securing bolts for defects and correct material grade. Must be Grade 8.8.
4. Check structures for corrosion and cracking of parent metal or weldment especially in highly stressed regions in the vicinity of securing and retaining pins or bolts. If in doubt use N.D.T. such as dye penetrant test to corroborate findings.
5. Check deck plates for damage and cracks. If in doubt, discard.
6. Check any timber fabric for security and damp rot. If in doubt discard.
7. Check any superficial covers for security.
8. Check general level of upkeep and comment in writing.
9. Check general condition of paint finish and corrosion, i.e. superficial or deep corrosion.
10. For general correctness of assembly, with particular attention to securing pins, i.e. positioned correctly or incorrectly.
11. Check bolts for correct torque and grade, i.e. 8.8

NOTE Prior to examination of 1 to 3 inclusive, degrease and clean thoroughly.

Prior to examination of 1 to 4, remove any paint or corrosion and clean thoroughly.

STRUCTURAL EXAMINATION

(SAFETY CRITICAL)

1. Safety critical areas must be examined periodically by N.D.T.
2. The maximum time period between examination of these areas is not to exceed 9 months.
3. The areas designated safety critical are depicted on page -5.09- and numbered 1 to 5.
4. These safety critical areas are to undergo an N.D.T. inspection of parent metal in the direct vicinity of joint weldment.

The joint weldment must also be given an N.D.T. inspection.

The inspection to examine the complete length of these joints.

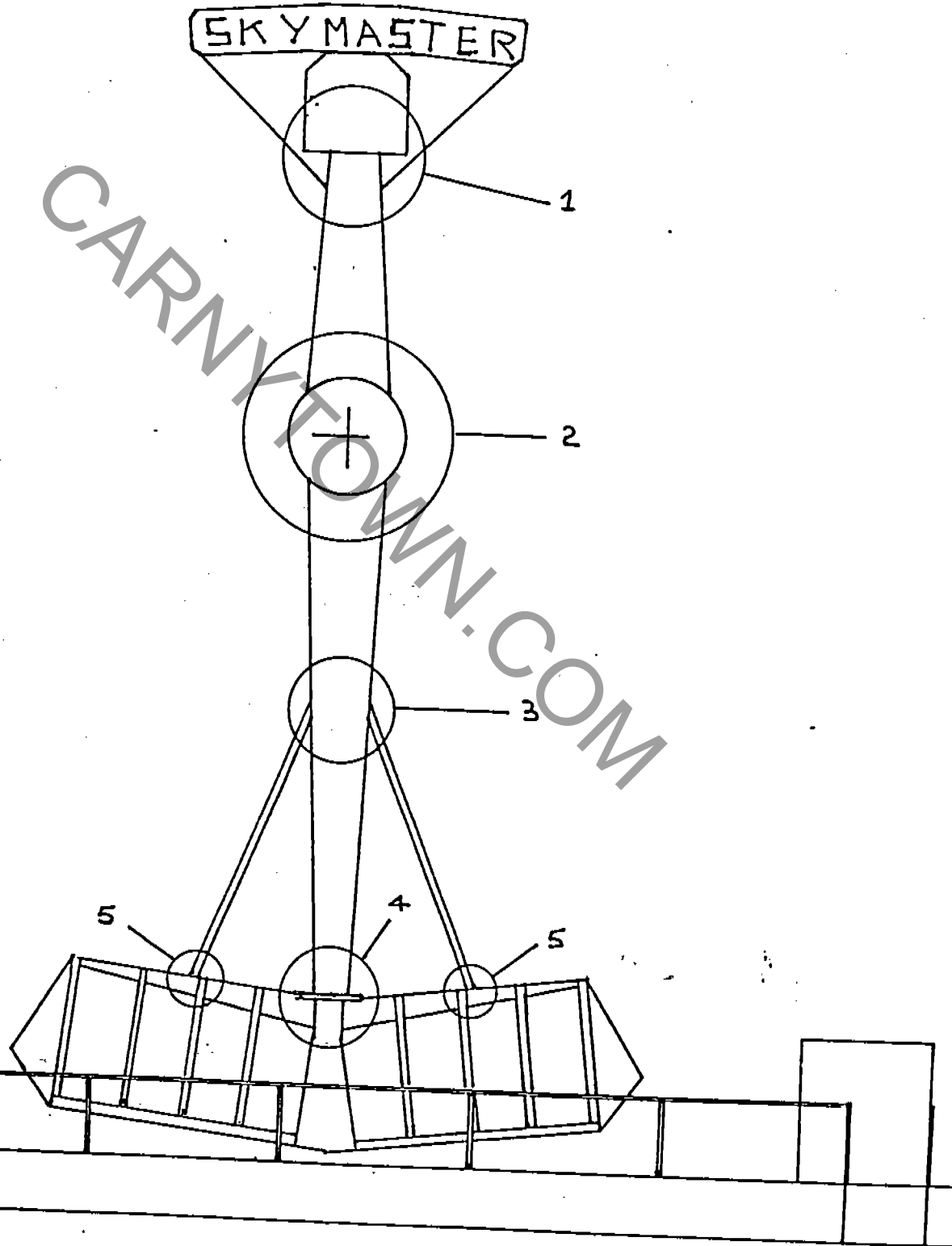

SAFETY CRITICAL AREAS

(SEE PAGE 5.09)

- 1)
 - a. Counterweight to arm joint
 - b. Counterweight gussets to arm joint
- 2)
 - a. Counterweight arm to drive centre joint
 - b. Hinge gussets to drive centre and arm joint
 - c. Tower top to main tower joint
- 3)
 - a. Tie rod brackets to arm joint
 - b. Tie rod end plate to tie rod tube joint
 - c. Tie rod threaded end (threaded root)
- 4)
 - a. Car mounting plate to car arm joint
 - b. Car mounting plate gussets to car arm joint
- 5)
 - a. Tie rod bracket to car roof joint
 - b. As 3b
 - c. As 3c

MECHANICAL EXAMINATION

1. Check slewing ring for roughness in operation, also check for play between races.
2. Check slewing ring for adequate greasing and any corrosion.
3. Check slewing ring drive gears for pitting, flaking and backlash.
4. Check slewing ring bolts for correct grade and torque.
5. Check passenger restraint device linkages for wear, lubrication and operation.
6. Check car slewing rings for roughness in operation and play.

ELECTRICAL EXAMINATION - 240 VOLT AND 416 VOLT A.C.

1. Check all generator terminals. Single or three phase are enclosed.
2. Check all sockets and connectors are of industrial type LE BS.4343.
3. Check that neutral points of conductors are connected to the metal enclosures of all the equipment and where possible be connected to an earth electrode via a protective conductor. The connection to earth should be made at one point, i.e. the generator.
4. Check no switches are inserted in any protective conductor and no single pole switch inserted in any neutral conductor.
5. Check if a rotary inverter is used to produce AC from DC earthing. Requires special consideration.
6. Check residual current circuit breakers for max setting of 30 MA.
7. Check residual current circuit breakers are installed in the conductors between earth reference point and the distribution equipment.
8. Check all metallic parts of the ride carrying electrical equipment should be bonded and connected to the protective conductors.
9. Check where the ride is on hard standing. It may not be possible to earth. It is imperative that protective bonding is checked regularly.
10. Check all cables are flexible multi-core with correct rating.
11. Check any flexible armouring is connected to system protective conductors.
12. Check all cable joints and terminations are mechanically protected and provided with the appropriate strain relief.
13. Check that any 13 amp domestic fitting is weatherproofed and properly supported.

14. Check all motor starters are provided with overload and short circuit protection and where restarting after power loss may cause danger is fitted with a device which opens the starter switch on loss of power.
15. Check all AC motors are totally enclosed.
16. Check that where 3 phase supplies are used for lighting the separate phases are at least 2 metres apart and clearly identified.
17. Check all fuses and circuit breakers are correctly rated.
18. Check all cables, couplers or plugs and sockets are connected so that live pins cannot be exposed.
19. Check neon lights are inaccessible and the transformer and cables are out of reach and weatherproofed.
20. Check that if AC and DC lighting is used, plugs and sockets are not to be cable or cross connections.
21. Check all parts of system for earth leakage and faults remedied.
22. Check continuity of protective conductors. Max voltage 50 volts, max current 25 amps. The measured value of resistance low enough to protect the system by removal of the supply in the event of short circuit to metal parts.
23. Check insulation resistance. Max test voltage 500v DC. The measured resistance to be not less than 1 megohm. Ensure test voltage is not applied across electronic components that may be damaged.
24. Check residual circuit breakers with suitable RCCB instrument. They should trip to the rated current. Also check the test button to ensure tripping mechanism is free.
25. Check all electrical enclosures are properly secured to prevent unauthorised access. Check where such enclosures are accessible to the public. They should be fitted with lockable handles so a tool is necessary to gain access.
26. Check interlocking control systems with wiring diagram to ensure system integrity is maintained after any modifications. The devices should be examined for mechanical wear and deterioration of insulation resistance between conductors and also checked for correct operation.

ELECTRICAL EXAMINATION - 110 VOLT DC

1. Check generator output is not connected to earth.
2. Check there is a generator isolator switch in each pole.
3. Check for correct fuses on output panel, one per pole.
4. Check isolators and fuses are not shorted out by wire links.
5. Check terminal connectors are brass not ferrous.
6. Check all exposed live points have covers of robust insulating material.
7. Check all metal enclosures are connected by low resistance bonding conductors, including the generator frame.
8. Check cables are flexible with tough outer cover, not metal armoured.
9. Check all cables are protected from mechanical damage by conduit etc.
10. Check all cables on output panel to be restrained to prevent strain on terminations.
11. Check if ride is on hardstanding, cables to be clear of main thoroughfare.
12. Check all joints to make good electrical contact and be of adequate mechanical strength and properly insulated. Twisted wire joints are not acceptable.
13. Check joints for signs of overheating and high resistance.
14. Check all motor starting systems incorporate a no-volt device to ensure that if supply fails it reverts to off position.
15. Check the resistance elements enclosure is adequately ventilated and robust.
16. Check all cable terminations, starters and motors are shrouded with robust covers.

17. Check all terminations under rides are shrouded and enclosed.
18. Check fuses are fitted in each pole at the starter to protect from overloads.
19. Check lighting circuits are fused against overloads.
20. Check flashing light contactor panels are enclosed.
21. Check all DC conductors and cables for faults to earth are correct.
22. Check continuity of bonding conductors. Test volts max 50v, current not exceeding 25 amps. Resistance of conductors 0.5 OHM max.
23. Check the insulation resistance of equipment. Max test voltage 500v, min resistance not less than 0.5 MEGOHMS.

HYDRAULIC EXAMINATION

1. Check hydraulic pump for smooth operation with no signs of cavitation, noise or leakage.
2. Check shaft drive coupling for wear and security (if not close coupled).
3. Check for hose or fitting leaking and kinked or damaged pipes.
4. Check any indicators on oil filters (where provided) for evidence of sludging.
5. Check oil filler cap is not sludged and tank is open to atmospheric pressure.
6. Check oil is not heavily contaminated, sludged or carburised.
7. Check any bundy tubing is not pitted or corroded.
8. Check drive motor for jerky running or loss of power (leakage).
9. Check circuit pressure is correct and within design specifications.
10. Check settings of any relief or cross over relief valves.
11. Listen for squealing noises from valves.
12. Check control linkage for smooth consistent operation.

PNEUMATIC EXAMINATION

1. Check for leaks in cylinders or pipework.
2. Check cylinder stems for pitting or corrosion.
3. Check cylinders for retention of fluid (water).
4. Check main filter for sludge and water retention.
5. Check cylinders for jerky or intermittent operation.
6. Check cylinders for bent rods.
7. Check main reservoir for leaks and retention of water.
8. Check all valves for function, especially the exhaust section.
9. Check pressure is within design specification.

TEST PROCEDURE

1. Request all parts found defective are replaced.
2. When satisfied that ride is erected in correct manner, request ride is operated unladen to maximum design speed.
3. Observe ride in unladen operating condition.
4. If satisfied, request ride be fully loaded to design specification.
5. Request ride is operated at maximum design speed.
6. Observe ride in fully laden operating condition.
7. Request ride be unloaded and re-examine as in:-

Structural Check List : 1-10

Hydraulic Check List : 1-12

Mechanical Check List : 1-15

8. If satisfactory, issue certificate and sign logbook.
9. If second examination reveals defects, downrate ride and repeat examination. Nature of defects should be communicated to manufacturer for their dissemination and appraisal.

2 YEARLY INSPECTION (NDT)

Every two years the machine should be submitted to non-destructive testing (N.D.T) of its structural components.

This should be carried out by an appointed person who is an independent examiner (as in the 12 monthly inspection) and an NDT technician certified to appropriate level in a nationally recognised certification scheme, viz:-

1. PCN - (Personal certification in N.D.T)
2. ASNT - (American Society of N.D.T)

Appropriate level for evaluation of results is level II. It is the responsibility of the appointed person to verify the technician is suitably qualified and agree the test method and technique to be used.

The appointed person must distinguish between original manufacturing flaws and ones developed during use. Also, he must distinguish between significant and insignificant flaws.

It is advised that the appointed person consults expert opinion as appropriate in the following disciplines:-

1. N.D.T.
2. Stress Analysis.
3. Welding Technology.

See checklist for N.D.T. of machines structure.

N. D. T. OF MACHINE'S STRUCTURE

RECOMMENDED METHODS OF N.D.T.

- | | | |
|----|------------------------|---------------------------------|
| 1. | Dye Penetrant Test | D.P.T. for (surface cracks). |
| 2. | Magnetic particle test | M.T. for (surface cracks). |
| 3. | Ultrasonic Testing | U.T. for (flaws and thickness). |

APPLICATION CHECK LIST

1. Check for surface cracks in parent metal at weld toes, edges of holes and any flamecut edges, in general terms in the vicinity of any stress raised.
2. Check for cracks in the surface of weldments. These should appear along the throat of the weldment.
3. Check for cracks in drive shafts in the vicinity of keyways, holes, changes in dia. or any other discontinuity.
4. For reduction in wall thickness in hollow sections caused by internal corrosion, also check for serious external corrosion (this is far less likely). This is important on thin wall sections in the vicinity of weldments and high stress areas.

NOTE Use DPT/MT for 1-3 after thorough surface preparation and degreasing of structural surface.

Use U.T. for 1-4. Remove paint and thoroughly clean coat with grease to give a good acoustic coupling.

On completion of testing, re-paint all surfaces.

SPECIFIC AREAS TO BE CHECKED

1. Check main arm Joint weldment (At mid position).
2. Check main arm to centre weldment.
3. Check car top beam and stay bracket weldment.
4. Check tower bolt block weldments.
5. Check tower to trailer weldment.
6. Check the rod end weldment.

NOTE : THESE ARE ALL AREAS OF MAX STRESS

Other areas to be checked are at the discretion of the appointed person.

Machine to be dismantled as in twelve monthly inspection to allow sufficient access for the N.D.T. technician and equipment.

THE FOLLOWING INFORMATION IS REQUIRED ON N.D.T. REPORT

1. Date of examination.
2. Technicians name and qualification.
3. Details of N.D.T. technique.
4. Parts examined and which elements comprised part of sample.
5. Parts unavailable for examination, if any.
6. Results of examination.

ALL REPORTS TO BE KEPT AVAILABLE BY THE RIDE OWNER

CARNYTOWN.COM

CARNY TOWN.COM

SECTION 6

MAINTENANCE

CARNYTOWN.COM









Due to the simple and robust design of the 'Skymaster', there is very little maintenance required and is limited to replacement of worn or damaged parts (see manufacturers recommendations), in addition to that shown below.

1. Maintain hydraulic fluid levels. As required
2. Replace hydraulic filters. As required
3. Maintain oil levels in drive gearbox As required EP 90
4. Lubrication of slewing ring Small amount daily GB
Lubrication of slewing ring gear boxes Small amount daily EP
5. Lubrication of driveshaft Weekly
6. Maintain oil levels in the air lubrication system & main compressor
Air service unit use Oil HL25 to Din 51524 150 VG 32
Compressor, Hydrovane 2000 or SAE 40 Deisel engine oil

Change oil yearly

CARNYTOWN.COM

LUBRICATION

MANUFACTURER	APPLICATION	AMBIENT TEMPERATURE
 ARAL	G.P. Aralub HLP 2	248K to 403K (-25oC to +130oC)
	E.P. Aralub LFZ 1	253K to 523K (-25oC to +250oC)
 BP	G.P. Energrease LS-EP 2	248K to 403K (-25oC to +130oC)
	E.P. Energol WRL	273K to 353K (-0oC to + 80oC)
 CASTROL	G.P. Spheerol EPL 2	253K to 393K (-20oC to +120oC)
	E.P. Grippa 33 S	253K to 353K (-20oC to +80oC)
 ELF	G.P. Epexa 2	243K to 393K (-30oC to +120oC)
	E.P. Cardrexa DC 1	253K to 393K (-20oC to +120oC)
 ESSO	G.P. Beacon EP 2	248K to 403K (-25oC to +130oC)
	E.P. Surett Fluid 4 k	253K to 373K (-20oC to +100oC)
 KLUBER	G.P. Cenoplex 2 EP	238K to 393K (-35oC to +120oC)
	E.P. Grafloscon CA 901	253K to 423K (-20oC to +150oC)
Mobil MOBIL	G.P. Mobilux EP 2	253K to 393K (-20oC to + 120oC)
	E.P. Mobiltac 81	243K to 393K (-30oC to +120oC)
 REINER	G.P. Stabyl LEP 2	253K to 393K (-20oC to +120oC)
	E.P. Ceplattyn KG 10	243K to 523K (-30oC to +250oC)
 SHELL	G.P. Calithia EP Fett T 2	248K to 403K (-25oC to +130oC)
	E.P. Cardium Fluid C	243K to 333K (-30oC to +60oC)
 TEXACO	G.P. Multifak EP 2	243K to 403K (-30oC to +130oC)
	E.P. Crater 2 X Fluid	253K to 393K (-20oC to +120oC)

G. P. = GENERAL PURPOSE

E. P. = EXTREME PRESSURE I.E. SLEWING RING GEARS ETC.

HYDRAULIC CIRCUIT

<u>ITEM</u>	<u>DESCRIPTION</u>
1	Three Phase Motor
2	Isolating Valve
3	External Gear Pump
4	Manual Two Way Valve
5	5 Stack Manual Spool Valve
6	Manual Spool Value
7	Hydraulic Motor on Winch
8	Pusher Ram (Tower)
9	Flow Control Valve
10	Main Lift Ram (Tower)
11	Velocity Fuse
12	Levelling Rams (Trailer)

SCHEMATIC HYDRAULIC CIRCUIT

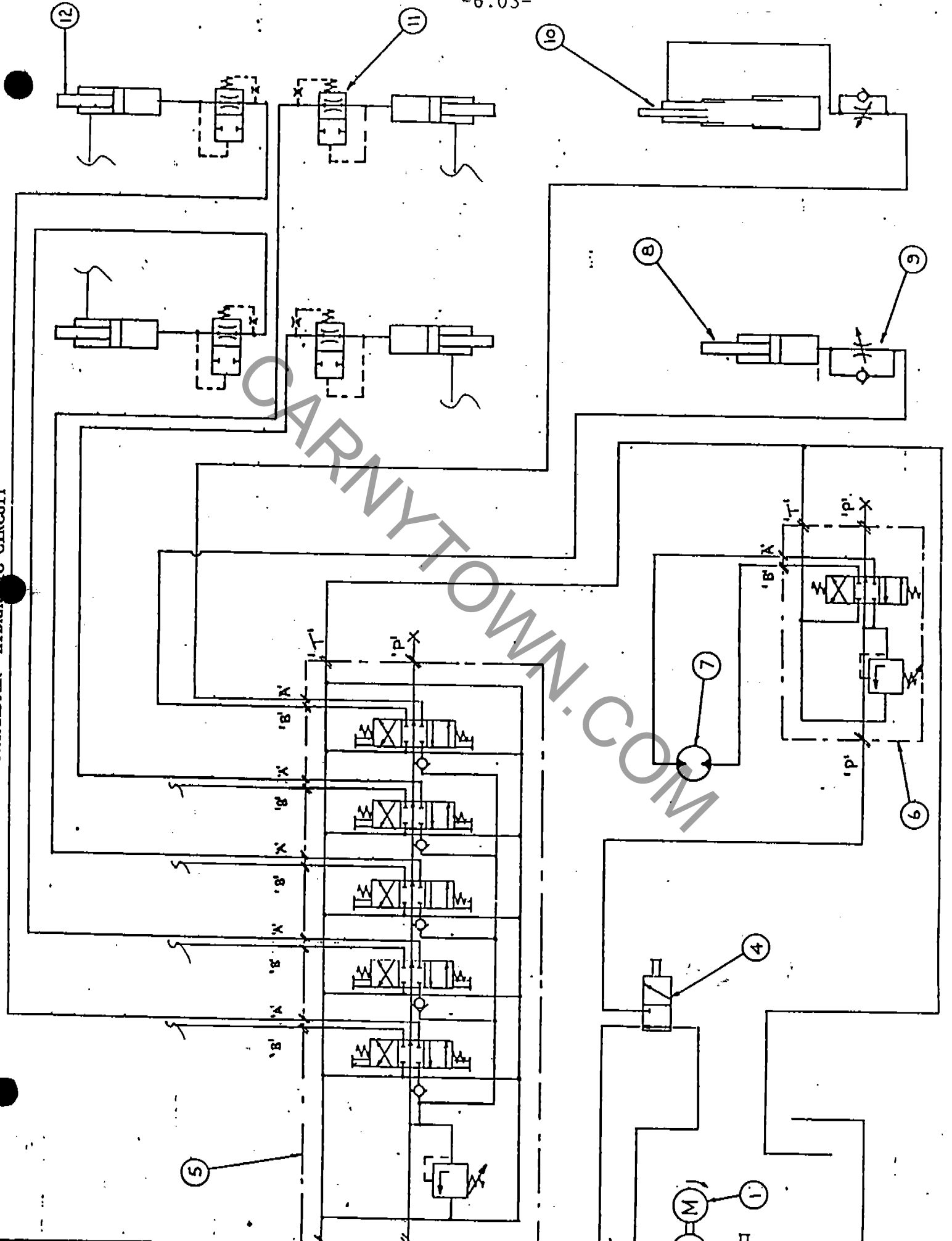

MANUFACTURERS RECOMMENDATIONS

- 1) It is recommended that the main arm drive pinions are replaced at intervals not exceeding 3 to 5 years depending on usage.

It is anticipated that wear and backlash will be in excess of recommended at this point in time.

- 2) It is recommended that all bolts in safety critical areas are discarded at the end of each season.

It is anticipated that damage from constant tightening and loosening will have rendered the threads unservicable after one season of operation.

NOTE Bolts must be replaced by the correct grade (U.T.S) and must carry certification to this effect.

BOLTS TO REPLACE IN SAFETY CRITICAL AREAS

- 1) Counterweight Hinge Fixing Bolts
- 2) Tower/Tower base fixing bolts
- 3) Car to car arm fixing bolts

CARNYTOWN.COM

SECTION 7

SERVICE BULLETINS

DATED JANUARY 28TH 1991

S U B J E C T

COUNTERWEIGHT ARM HINGE FIXING BOLTS

- 1) In view of the prevalence of counterfeit bolts purporting to be bona-fida grade 8.8 or better, the following course of action has now been implemented.
- 2) Special purpose nuts with reduced hexagons (M30 x M24 hexagon) that enable torque to be accurately established are to be retro-fitted on serial numbers SKY 1 to 8.
- 3) Rides with serial numbers SKY 9 onwards are now modified to allow a standard socket and nut to be utilised.
- 4) To further guard against the possibility of counterfeit bolts, a back up shear pin with bracketry is to be retro-fitted to serial numbers SKY 1 to 6. All rides from SKY 7 will have this as factory fitted.

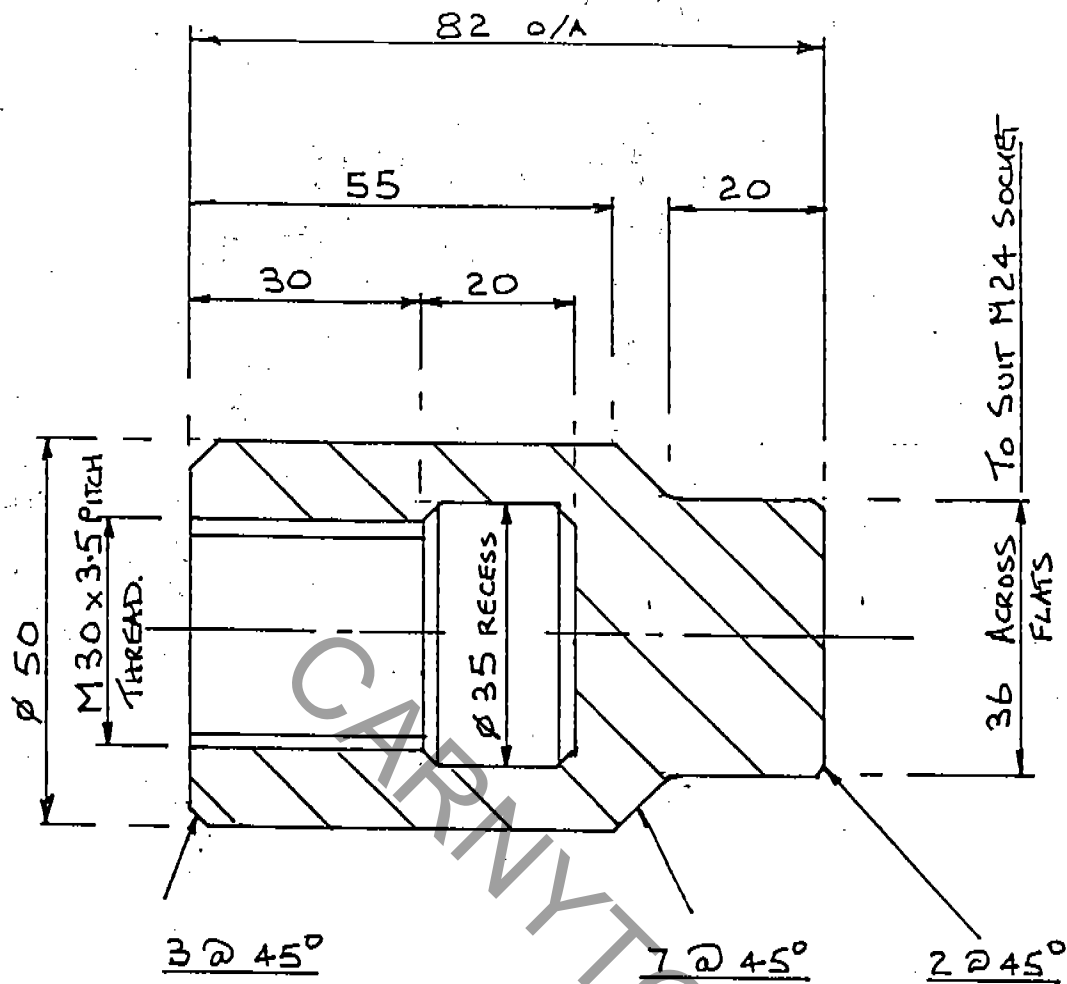

SECTION 'A-A'

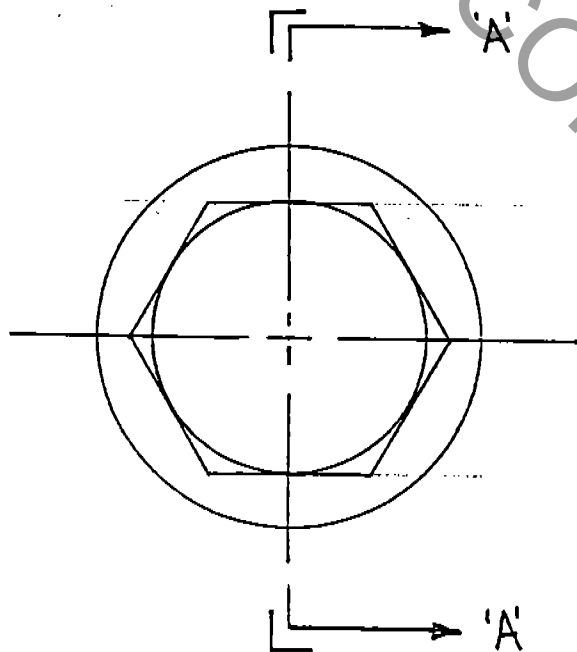

MAT^L EN8 (080M40) BRIGHT ROUND

SPECIAL NUT FOR "SKYMASTER" 4-DEF PER SIDE

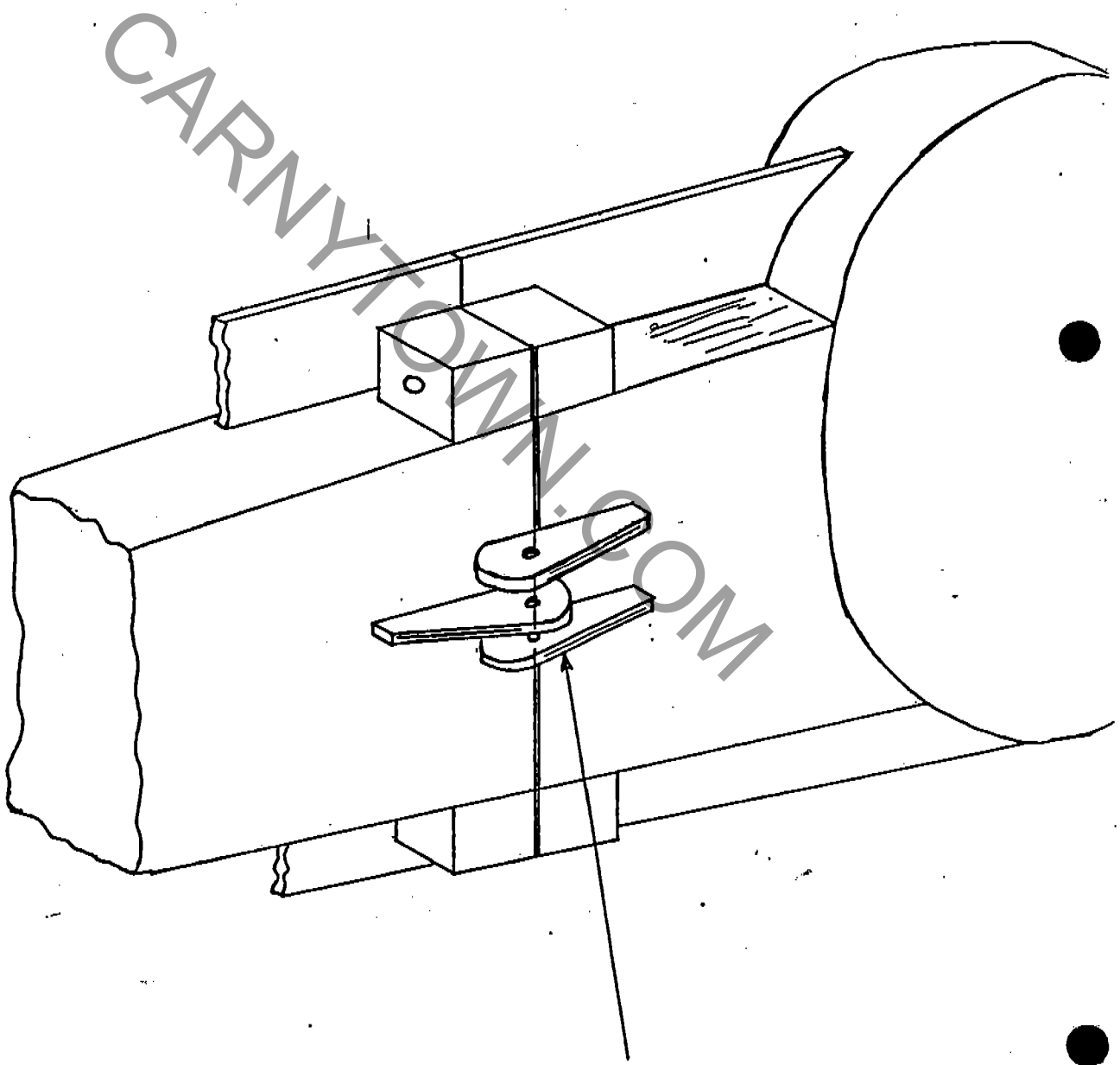

BACK UP SHEAR PIN BRACKET

SEPTEMBER 29, 1994

365



TO ALL SKYMASTER AND HIGHFLYER OWNERS:

USA Office:
Box 2042, Wintersville, Ohio 43952
Telephone: 614 264-6599 Fax: 614 266-2953

SERVICE BULLITIN:

RE: LAP BAR PAWLS

THIS IS TO INFORM SKYMASTER AND HIGHFLYER OWNERS THAT THE PRACTICE OF LOADING OF PASSENGERS WITH THE LAP BARS IN THE "UP" POSITION, AND THE "LOCKED" POSITION, WILL SPEED UP THE NORMAL WEAR & TEAR OF THE PAWL TOOTH.

WHEN A PASSENGER IS LOADED AND PULLS THE LAP BAR DOWN, AND IT RATCHETS, WE HAVE FOUND WILL EXPEDITE THE PAWLS NORMAL WEAR.

WE RECOMMEND LOADING OF THE RIDE, THEN ALL LAP BARS BE PULLED DOWN BEFORE LAP BARS ARE "LOCKED" AND THEN CONFIRMED ALL ARE SECURE BY THE OPERATOR.

PAWLS SHOULD BE CHECKED, AT THIS TIME, FOR WEAR & TEAR AS IN THE ENCLOSED DRAWING.

RECEIVED

JAN 31 1995

Funfair Equipment, Design, Manufacture and Refurbish

A.R.M. (U.K.) LTD
Unit 1, Enstone Airfield, Enstone, Oxford OX7 4NW, England

Telephone (0608) 677468
Fax: (0608) 678765

Directors: M. Steffens, S. Steffens
V.A.T. No. 348-3613-46
Registered in England No. 1534898



CARNYTOWN.COM

CHECK LAP BAR PAWL TIP FOR WEAR AND DEFECTS.

MAXIMUM TIP WIDTH NOT TO EXCEED 1.5mm.

IF WEAR EXCEEDS THIS AMOUNT THEN REPLACE WITH A NEW FACTORY UNIT.

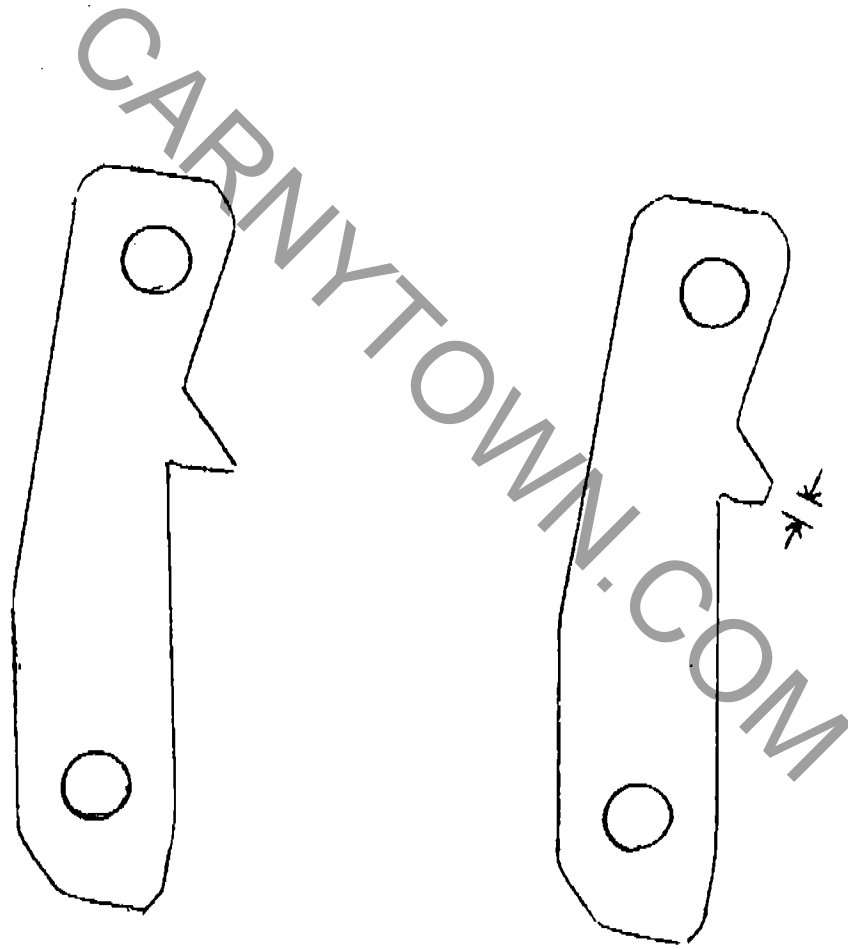

Approximate 1/8"

MAX.
WEAR
EXCEEDS
1.5mm

NORMAL

EXCESSIVE WEAR

SIDE VIEW OF PAWL

CARNYTOWN.COM

AUGUST 1, 1994



ALL HIGHFLYER OWNERS

USA Office:

Box 2042, Wintersville, Ohio 43952

Telephone: 614 264-6599 Fax: 614 266-2953

SERVICE BULLITIN:

RE: HIGHFLYER 1:

PLEASE NOTE FROM THE ENCLOSED DRAWING THAT A SMALL SURFACE CRACK WAS NOTED ON HIGHFLYER 1 (ENGLAND) AT THE TOP OF THE GUSSET LOCATED ON THE COUNTERWEIGHT ARM.

PLEASE AMKE A VISUAL INSPECTION OF YOUR HIGHFLYER.

THIS CAN EASII.Y BE VIEWED THRU THE HATCH LOCATED AT THE TOP OF THE TOWER.

PLEASE REPORT ANYTHING IRREGULAR TO OUR U.S. OFFICE.

IF YOU HAVE ANY FURTHER QUESTIONS, FEEL FREE TO CALL.

Funfair Equipment, Design, Manufacture and Refurbish



A.R.M. (U.K.) LTD.
Unit I. Enstone Airfield,
Enstone, Oxford OX7 4NW, England

Telephone (0608) 677468
Fax: (0608) 678765

Directors: M. Steffens, S. Steffens

V.A.T. No. 348-3613-46

Registered In England No. 1534898

CARNYTOWN.COM

BI - ANNUAL

Shy Master

GENERAL N.D.T. INSPECTION.

CARNY TOWN.COM

CARNYTOWN.COM

Two Yearly Inspection (N.D.T.)

Every two years the machine should be submitted to non - destructive testing (N.D.T.) of its structural components.

This should be carried out by an appointed person who is an independent examiner (as in the annual inspection) and an N.D.T. technician certified to appropriate in a nationally recognised certification scheme, viz :-

- 1) PCN - (Personal Certification In N.D.T.)
- 2) ASNT - (American Society Of N.D.T.)

Appropriate level for evaluation of results is level 2. It is the responsibility of the appointed person to verify the technician is suitably qualified and agree the test method and technique to be used.

The appointed person must distinguish between original manufacturing flaws and ones developed during use. Also he must distinguish between significant and insignificant flaws.

It is advised that the appointed person consults expert opinion as appropriate in the following disciplines :-

- 1) N.D.T.
- 2) Stress Analysis.
- 3) Welding Technology.

See checklist for N.D.T. of machine structure.

CARNYTOWN.COM

N.D.T. Inspection.

Recommended Methods Of N.D.T.

- 1) Dye Penetrant Test DPT For surface cracks.
- 2) Magnetic Particle Test MT For surface cracks.
- 3) Ultrasonic Testing UT For flaws and thickness.

Applications checklist

- 1) Check for surface cracks in parent metal at weld toes, edges of holes and any flamecut edges, in general terms in the vicinity of any stress raisers.
- 2) Check for cracks in the surface of weldments. These should appear along the throats of weldments.
- 3) Check for cracks in drive shafts in the vicinity of keyways, holes, changes in diameter or any other geometrical discontinuity.
- 4) Check for reduction in wall thickness in hollow sections caused by internal corrosion, also check for serious external corrosion (this is less likely). This is important on thin walled hollow sections in the vicinity of weldments and high stress areas.

Note:-

Use DPT/MT for 1 to 3 after thorough surface preparation and degreasing of structural surface.

Use UT for 1 to 4 . Remove paint and thoroughly clean, coat with grease to give a good acoustic coupling.

On completion of testing, re- paint all surfaces.

CARNYTOWN.COM

Specific Areas To Be Checked

- 1) Check main arm joint weldment (At mid position).
- 2) Check main arm to centre weldment.
- 3) Check car top beam and stay bracket weldment.
- 4) Check tower bolt block weldment .
- 5) Check tower to trailer weldment .
- 6) Check tie rod end weldment .

Note : These Are All Areas Of Maximum Stress

Other areas to be checked are at the discretion of the appointed person .
Machine to be dismantled as in annual inspection to allow sufficient access for the N.D.T. technician and equipment.

The Following Information Is Required On N.D.T. Report.

- 1) Date of examination.
- 2) Technicians name and qualification.
- 3) Details of N.D.T. technique.
- 4) Parts examined and which elements comprised part of sample.
- 5) Parts unavailable for examination, if any.
- 6) Results of examination.

All Reports To Be Kept Available By The Ride Owner

CARNYTOWN.COM