

MFG: A.R.M. (UK) LTD.
NAME: QUASAR
TYPE: NON-KIDDIE

Number: S.B.QSR 001

Date: 8th Oct 1993

Supercedes: N/A

SERVICE BULLETIN

Effective Serial Numbers: All Quasars

Subject: Cracks found on 'H' Frame.

It has been noted that one Quasar has developed cracks on the 'H' frame upper pivot points, radiating from the hinge pin holes (see attached sketch).

All operators must inspect for cracks in this area. If any cracks are found, please inform the manufacturer and ensure that the ride is not used until repairs have been carried out.

A Repair bulletin will follow shortly.

A.R.M. (U.K.) LTD.
Unit 1, Enstone Airfield,
Enstone, Oxford OX7 4NW, England
Tel:(0608) 677468 Fax:(0608)678765

USA Office
Box 2042, Wintersville
Ohio 43952
Tel: 614 2646599 Fax: 614 2662953

CARNYTOWN.COM

QUASAR SUB-FRAME

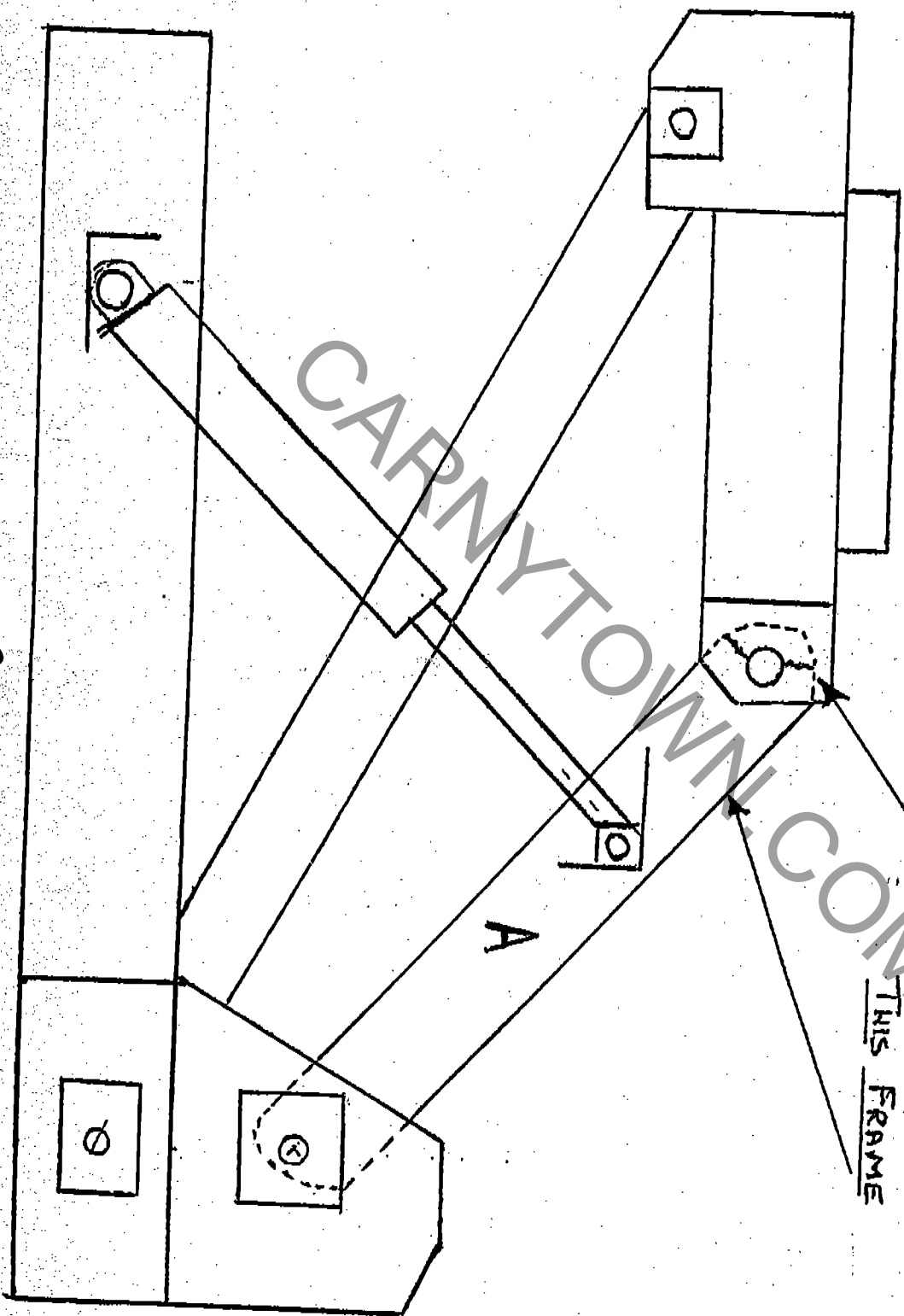

C RACKS FOUND ON 'H' FRAME AT THIS POINT
BOTH SIDES

THIS FRAME

CARNYTOWN.COM

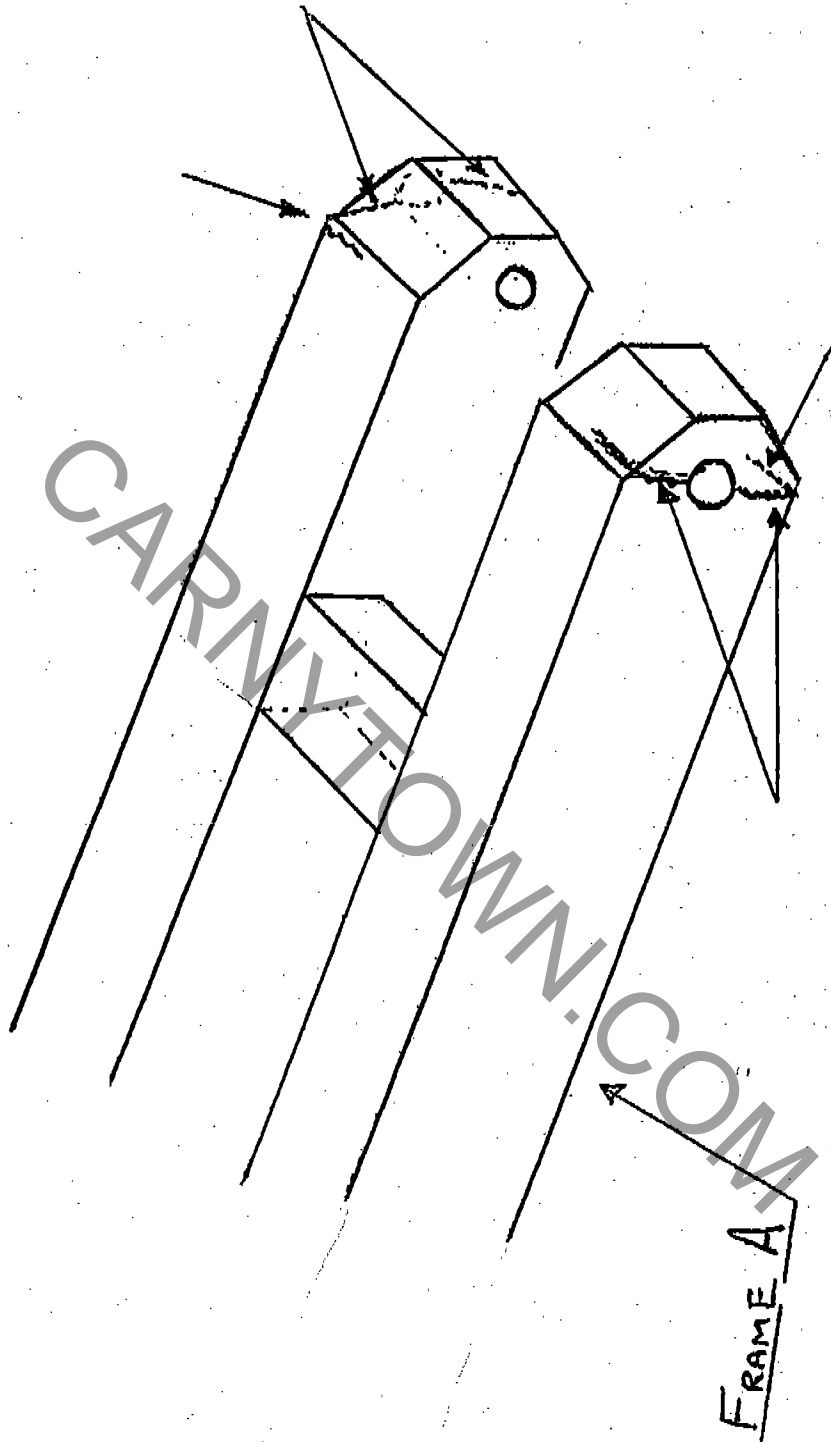

CRACKS RADIATING FROM HINGE PIN HOLES BOTH SIDES.

AND RUNNING ACROSS BOX SECTION

CARNYTOWN.COM

QUASAR
INSTRUCTION
MANUAL

CARNYTOWN.COM

3rd November 1986

Quasar Operating Restrictions

1. Maximum speeds:-

16 revolutions per minute forwards

12 revolutions per minute in reverse

These speeds must not be exceeded

2. Minimum passenger height:-

Unaccompanied by an adult, 48 inches (1220 mm)

An adult is likely to use his own judgement when

accompanying a child, but we suggest that the

Quasar is not really suitable for children

smaller than 36 inches (915 mm) in height.

CONTENTS

	<u>Page</u>
1. Introduction	1
2. Build-Up Instructions	4
3. Safety Check and Maintenance Procedure	12
4. Operating Instructions	18
5. Operating Hints	19
6. Replacement Parts	20
Addenda	21
7. Component Location	24
8. Electrical Wiring Diagram	27
9. Programmable Logic Controller	32
10. PLC Ladder Diagram	36
11. Hydraulic Circuit Schematic	42

1. Introduction

The Quasar is a new type of amusement ride which has already proved to be a big money earner. Furthermore, our high opinion of the ride appears to be shared by the trade, as the Quasar received the award for the best non coin-operated exhibit at the 1985 Amusement Trades Exhibition International at Olympia, London.

The Quasar is one of the 'stable' of rides manufactured and sold by A.R.M. (UK) Ltd, Enstone Airfield, Enstone, Oxford OX7 4NW, England. A.R.M. (UK) Ltd is now the largest manufacturer and refurbisher of amusement rides in the UK. As such we take the greatest care to ensure the quality, safety and serviceability of our products.

The structural design of the Quasar was carried out by independent consulting engineers Wilson Consultants, Brook Farm, Wilson, Melbourne, Derby DE7 1AH, England - the UK leader in stress analysis of amusement rides. Due to the technical complexity of an advanced ride of this type, the majority of the design analysis was carried out by digital computer. It is thought that the Quasar may be the first rotating ride for which this claim can be made. The accuracy and detail which has resulted from this approach has allowed careful design against future fatigue problems and we believe that the result is a safe ride with good long-term serviceability.

Manufacture of the ride in our Enstone factory has fully incorporated the design specification. The quality of workmanship is inspected, using NDT techniques where appropriate, on all major components of each Quasar. This, truly independent, inspection is carried out by Robert Ward Engineering Services, P.O. Box No. 9, Buxton, Derbyshire SK17 9XF, England - the foremost amusement ride inspection engineers in the UK.

In the following pages we include the information necessary to satisfactorily operate the Quasar, but emphasis should particularly be placed on the regular safety checks and maintenance procedures. Although the design incorporates several levels of safety and the components should give good life when the ride is operated in accordance with the instructions in this manual, these checks must be considered essential.

For instance, in the absence of its two motion dampers and its two wire restraint bonds a car may undergo a dangerous motion. Now, if one damper fails a car will operate safely under the control of the remaining damper. If the second damper then failed the car would have to rely on the limiting action of the wire restraint bonds until the ride could be stopped. Thus these features of the design provide multiple levels of safety. Nevertheless it is the intention of our design consultants and ourselves that all of these elements of the ride should be

operating correctly and ON NO ACCOUNT SHOULD THE QUASAR BE OPERATED WHEN ANY OF THESE SAFETY DEVICES ARE NOT IN GOOD ORDER.

Some of the other procedures are basic, common-sense, maintenance. These are nevertheless important to ensure continued safety and serviceability of the Quasar.

CARNYTOWN.COM

2. Build-Up Instructions

1. Apply the trail Automatic brake now fitted of rear wheels.
2. Connect mains power at the box under the front swan neck.
3. Place large area packing blocks under the feet of the hydraulically operated jacks. This limits surface pressure and minimises sinking.
4. Place the wheel chocks in position.
5. Switch on the pump and raise the trailer on the front hydraulic jacks to release the tractor unit. These are operated from the levers adjacent to the nearside (left) wheels.
6. Remove the two top stays which hold the floors in the upright, folded position.
7. Each side of the trailer has two pins holding the floor into the trailer side. These should now be removed.
8. Each side of the floor, in turn, should be pulled out by approximately 5 ft (1500 mm) and two stays should be placed in position. Holding the sides out in this fashion allows good access to the levelling jacks, packing points etc.
9. Open out the four main outriggers, replacing the pins and clips.
10. Levelling of the Quasar must be carried out carefully using the four hydraulic jacks and to assist you the following guidelines are given:-

- a) On perfectly flat ground with no slope the chassis will be at an angle of 4 degrees to the horizontal, lowest end at the front. To assist in setting this angle there is an appropriately inclined ledge, on which to place a spirit level, located on the nearside (left) of the chassis. When the ground is not flat and horizontal the spirit level will be misleading.
- b) When the ground is not horizontal levelling is simplest when the trailer is pointed directly uphill.
- c) Note that, for instance, raising the rearmost jacks not only raises the rear end of the trailer but also lowers the front end. It is therefore not possible to level the trailer one corner at a time.
- d) Ultimately the front edge of the trailer will need to be approximately 24 ins (600 mm) above ground level, while the back panel fittings at the rear of the trailer will be approximately 60+ ins (1530 mm) above ground. These levels allow space for fitting the shutters or skirts around the outside of the ride.
- e) To achieve the levels mentioned in d) it may be found simpler to adjust the levelling jacks until the rear end levels are approximately 36 ins (930 mm) higher than the front end levels. It will then be possible to calculate the distance through which all four jacks must be raised or lowered. This may then be done, one by one, by placing a scale against each jack in turn and carrying out the necessary adjustment.
- f) Please note that the trailer wheels will normally be clearly off the ground.

11. The six main packing points are under the four corners and the two mid-points of the lower section of the chassis.

12. Place threaded supports under outriggers with packing as required. Tighten the nuts so that positive load is applied to the outriggers.

13. Note that the numerous screw jacks for supporting the floor, steps etc are colour coded to save time in assembly. At this stage the floor support sections and screw jacks should be unloaded and laid out according to the colour codes visible on the underside of the floor framework.

14. One black coded screw jack should be fitted on the channel cross-member behind the rear wheels and adjusted as appropriate.

15. Remove the bracing bar from the front of the ride to lower the operating platform which should be supported on two yellow coded screw jacks.

16. Each of the four deck outriggers, which attach to the main outriggers, should be supported on two of the grey coded screw jacks. Note the method of jack location. When the Quasar is sited on flat, horizontal land or is pointed uphill with no transverse slope the spirit level ledge on the forward face of each outrigger may be used when making adjustments to the screw jacks.

17. There are spacer bars and diagonal braces to fit between the pairs of deck outriggers. These should be in position before the screw jacks are tightened.

18. An external cable (24V DC) for powering the deck lowering winch should be plugged in between winch and transformer (under the right hand side of the front swan neck). Switch on the transformer for winch power.

19. Climb up to the top of the bobbin, lift the winch hood, and attach the 'Pendant Control Station' for winch operation.

20. While travelling, the winch cable is passed round both deck hangers as an extra level of security. The cable should now be unfastened and connected to just one of the sides. When safely connected, the turnbuckle holding the floor in the vertical position should be removed. As winching down of the floor proceeds the lower edge needs to be eased out by hand to ensure that the floor descends smoothly. When the floor is fully down the winch hook may be released and the deck hanger removed.

21. The colour coded screw jacks should now be correctly located and adjusted to provide full support to the floor area. It is now safe to walk on.

22. The procedure in paragraphs 20 and 21 may now be repeated for the floor at the other side of the trailer.

23. When the winching operations are completed, switch off the transformer providing winch power and disconnect the power cables. Lower the winch hood and secure using the two clips provided.

24. Remove the braces which hold the backdrop panels in their travelling position. Each side of the backdrop is also held by two clips underneath the chassis near the trailer wheels. When these have been removed the panels may be opened out and located over the pins on the edge of the deck. If any difficulty is encountered in locating these the adjacent floor support screw jacks may need slight adjustments.
25. Raise the QUASAR backflash from its folded down position and locate the appropriate pins.
26. Slot in the remaining (top) backdrop sections.
27. Slot in the two long pillars at the edges of the backdrop. These are braced by stays attaching to the underneath of the deck.
28. The remaining side pillars slot into position around the outer edge of the deck.
29. Attach the numbered handrails so as to correspond to the pillar numbers.
30. Hang the numbered decorated shutters or skirts around the outside of the deck. One or more of the larger panels may be omitted for the time being to allow access for storage of equipment beneath the floor.
31. Raise and bolt the control panel in the upright position on the operating platform.
32. Slot in the shutters around the operating platform.

33. The steps should now be set up. These slot onto the front of the deck framework and are supported by the very short grey coded screw jacks. Adjoining sections of steps share a common screw jack.

34. Erect the paybox using the eight pins to fasten together the four walls. The roof should then be placed in position and clamped at front and rear.

34a. Screw down the turntable support screw jacks.

35. The main radial arms of the ride may now be opened out. Care should be taken not to foul the front-facing arm lights on the car cradles. As each radial arm is opened out the pins and security clips should be carefully fitted at the bobbin.

36. The short linking arms should now be opened and connected, by the pins and security clips, between adjacent radial arms. Connect the lighting plugs from the radial arms to the link arms.

37. The two adjustable link arms should, by measurement, be set to be as near as possible the same length as each other. This should ideally correspond to approximately 1630 mm between the ends of the pivot balls. Final setting should leave the link arms in tension rather than compression. They should only infrequently require any adjustment.

38. Remove the hollow sections bracing together the car travelling cradles.

39. Load the cars onto the ride in numbered order corresponding to the numbers marked on the radial arms. Maintaining the same order reduces the frequency at which pivot block adjustments are required. The procedure for dealing with each car is as follows:-

- a) Remove the car from its travelling cradle rear end first. Care must be taken to avoid the arm lights when moving the cars.
- b) Before mounting the car on its pivots the pivot blocks should be examined for signs of damage, wear or scoring. Excess wear debris should be removed as foreign bodies in the pivots will accelerate scoring and wear.
- c) Push the fixed pivot block fully onto its ball. Push the loose pivot block onto the other ball and, while holding the block in correct alignment, lower its housing onto it. Bolt the block into the housing taking particular care that the rearmost bottom bolt is properly tightened. This bolt, more than the others, nips up the housing to grip the pivot block.
- d) Check the pivot blocks for end float by pushing and pulling the car in a tangential direction. Any slack should be removed by loosening the bolts clamping the fixed pivot block and tightening the adjusting screw. The adjusting screw lock nut and the pivot block clamping bolts should then be retightened. Note that such adjustments should rarely be necessary if the cars are always located between the correspondingly numbered radial arms.
- e) Connect the shock absorbers to the brackets located on top of the pivot block housings using the pins and retaining clips.

f) Attach the car restraint safety cables.

g) Connect the lighting plugs from radial arms to cars.

40. Remove and stow away the car travelling cradles and other equipment.

41. Hydraulic supply must be diverted from the levelling jacks to the ride. This is achieved by changing the direction of both ball valves mounted between the main chassis members near to the lift pump to the rear of the centre. This operation must NOT be carried out with the pump running.

42. Raise the ride on the hydraulic rams to allow the travelling prop to be removed.

43. Carry out safety checks and required maintenance procedures before operating the ride.

44. Pull down procedure is basically the reverse of build-up.

3. Safety Check and Maintenance Procedure

Daily

1. Check that all lap bar bolts are tight and that all catches are operating correctly. Note that it is possible for the catch springs to break as a result of fatigue (ARM Part No. Q-107). DO NOT USE ANY CAR ON WHICH THE LAP BAR DOES NOT LOCK AS INTENDED.
2. Each car incorporates two wire restraint bonds attaching to the adjacent main radial arms. Although normal operation should not cause damage to these, they should be visually checked daily for signs of loose fixing bolts, broken wires, or other damage. ANY DAMAGED WIRE RESTRAINT BOND SHOULD BE REPLACED IMMEDIATELY. (ARM Part No. Q-106).
3. To check the operation of the car motion dampers pull each car outwards until the lap bar lock reaches waist height. Upon releasing the car it should fall back to its rest position without vibration. If this is unsatisfactory the motion dampers (ARM Part No. Q-103) must be individually checked. ON NO ACCOUNT OPERATE THE RIDE UNTIL THIS TEST CAN BE PASSED BY ALL SIXTEEN CARS.
4. Note that all pins are retained by clips. A daily visual inspection should be made to ensure that all clips are present. The pins locating the car motion dampers should be directed such that each clip faces the car interior.

5. The four main outriggers rest on adjustable supports. Check these every day and adjust as required.

6. The rotary hydraulic coupling, located inside the base of the rotor lifting linkage, has two grease points. These should be greased daily using Castrol MS3 or equivalent. WHEN WORKING INSIDE THE RAISED LINKAGE THE SAFETY PROP SHOULD BE IN POSITION.

7. Both slewing ring gears and their pinions should be lightly sprayed with gear grease daily or as conditions require but certainly not less than once per week.

Weekly

1. The car motion dampers should be visually checked weekly in the region of the piston rod oil seals for loss of oil. Although these seals should have a considerable life, any unusual ingress of dirt particles etc. may cause seal damage, oil leakage, and resultant loss of damper function. A DAMPER MUST BE REPLACED IMMEDIATELY WHEN OIL LOSS BECOMES EVIDENT. (ARM Part No. Q-103).

2. Each car motion damper is attached to its radial arm via a rubber bush in the cylinder eye. This bush should be checked for damage or loss of rubber. They may need periodic replacement (ARM Part No. Q-101). The self-locking nut which retains the bush should not be tightened far enough to compress the rubber as this accelerates wear. At the other end of the motion damper

the piston rod is terminated by a spherical bearing (ARM Part No. Q-102). This should be greased and checked to ensure that correct spherical action is possible.

3. The top slewing ring has three greasing points accessible via the bobbin inspection hatches. These must be greased weekly.

4. Likewise the bottom slewing ring must be greased weekly. Access to the three greasing points is near the bottom slip ring assembly. **WHEN WORKING INSIDE THE RAISED LINKAGE THE SAFETY PROP SHOULD BE IN POSITION.**

5. Both slewing ring gears and their pinions should be lightly sprayed with gear grease daily or as conditions require but certainly not less than once per week.

6. The rotor lifting and tilting linkage articulates about four large shafts having, in total, eight greasing points which must be serviced weekly.

7. Each ram is mounted via spherical bearings on pins at either end. These four pins should be greased weekly.

8. Each ram also has its own grease nipple which must be given one squirt each week.

Two Weekly

1. Due to a settling effect after some hours work IT IS ESSENTIAL that the slewing ring bolts of a new QUASAR are retightened to a torque of 860Nm. This should be carried out every two weeks for the first two months and thereafter once every three months.

Monthly

1. Every car is mounted on two spherical balls through blocks of low friction material. These blocks should have a considerable wear life. A visual inspection should be carried out every month to detect any abnormal or excessive block wear or splitting. Corrective action will depend upon the symptoms.

2. One of the effects of block wear is that some car end float may develop between the spherical balls. Having inspected the blocks (in 1 above), any end float should be adjusted out when the car is remounted. If this is not done then block wear will be accelerated. Adjustment is carried out as described in the Build-Up Procedure (page 10).

3. The level of hydraulic oil should be checked each month. The volume should be made up with oil to ISO Viscosity Grade 68.

Three Monthly

1. All slewing ring fixing bolts should be checked to ensure that the tightening torque of 860 Nm still holds. Note that this must be carried out every two weeks for the first two months when your Guasar is new.

Six Monthly

1. The wire car restraint bonds attach to the ends of the main radial arms by means of a bolt bearing in three plates. A visual inspection should be made for hole or bolt wear. In normal circumstances wear should be negligible.

2. All pins and pin holes in the main arms, link arms and bobbin should be checked for signs of wear.

Annually

1. Check the car pivot balls for signs of scoring. This may occur if dirt or grit inclusions penetrate into the blocks of friction material. The importance of checking the cleanliness of the blocks at build-up is therefore emphasised. Scored ball pivots can cause accelerated block wear. In the case of a severely scored ball pivot consideration will need to be given to replacement. (ARM Part No. Q-105).

2. Change hydraulic oil filter.

Three Yearly

1. Once in every three years the hydraulic oil should be changed. This will require 95-100 gallons of oil to ISO Viscosity Grade 68.

CARNYTOWN.COM

4. Operating Instructions

1. The ride operator has the choice of manual or automatic operation selectable from a key-turned switch. Automatic operation is described in paragraphs 2-4, and manual operation in paragraphs 5-7.
2. There are four buttons which turn on and off the hydraulic pumps and electrical power. The large red 'Emergency Stop' button will cut all power and should be used in the event of an electrical fire or fault. The pumps will normally be left running during operation but 'Stop Pumps' will turn these off at the end of the day.
3. There are three key-selectable operating cycles in the automatic mode. Two of these involve a change in direction of rotation during the ride cycle. One of these choices has reverse rotation as the first part of the cycle and the other has forward first. The third automatic cycle has forward rotation only.
4. Note that the maximum speeds and rotor tilt are fixed and the automatic cycle time has also been factory pre-set to the customer's requirements. This cycle time may be cut short by pressing the 'Stop Ride' button.
5. In the automatic mode, the buttons are once again fairly self-explanatory. The 'Stop Ride' button allows the operator to rotate the ride. The ride will continue as long as the button is held down. The 'Stop Ride' button is immediately prior to a ride cycle, to allow the operator to carry out a final check that the lap bars are locked.

NO LONGER FITTED

6. Reverse rotation should not be selected until the ride has been brought to a halt and the rotor lowered to less than half its maximum height. Ignoring this instruction will result in an undesirable, unpleasant motion.

7. Raising and lowering of the rotor is operated from a single switch.

5. Operating Hints

1. Keep the ride loading balanced when not running full.
2. Before starting, be sure that all passengers are seated and that there are no spectators inside the safety barriers.
3. On starting, the safety lap bars may be re-checked on the first, slow revolution of the ride.
4. During running, ride attendants should remain alert and keep eyes on the ride and safety barriers at all times.

6. Replacement Parts

It is possible that certain small components (e.g. lap bar catch springs, wire restraint bonds) may require replacement at some future date. Some of these have been given ARM Part Numbers in the list below.

- Q-101 Damper rubber bush
- Q-102 Damper spherical bearing
- Q-103 Car motion damper
- Q-104 Car pivot blocks
- Q-105 Car ball pivots
- Q-106 Wire restraint bond
- Q-107 Lap bar catch spring

For these and other Quasar parts please contact A.R.M. (UK) Ltd who will be pleased to deal with your enquiry.

QUASAR Instruction Manual - Addenda

Following requests for additional information we draw attention to the following points:-

1. Wear of Car Pivot Blocks

With reference to paragraph 39 d) in the Build-Up Instructions and paragraph 2 in the Monthly Maintenance Procedure it is noted that, if end float still remains after tightening the block adjusting screw to its limit (10 mm maximum block movement), then block wear is excessive and the block should be replaced. (ARM Part No. Q-104).

With respect to block ovality, having first adjusted for end float, any ball/hole clearance allowing in excess of 3mm of movement in any direction perpendicular to the ball pivot axis is to be considered excessive. The block should be replaced.

Note that, provided that the regular checking and adjustment procedure is followed, block wear should be very slow.

2. Wear of Ball Pivots

The spherical ball forming the basis of each car pivot is accurately manufactured from a special steel with Ultimate Tensile Strength at least 78000 lbf/sq in (50 N/sq mm). In

combination with its pivot block the coefficient of friction and wear rate should be low. Significant wear of the spherical ball is not anticipated unless abrasive materials are allowed to become embedded in the block material and are not removed. If any diameter on the spherical portion of the ball falls below 48 mm then the car ball pivot should be replaced (ARM Part No. Q-105). Note that this is not considered to have any serious consequences for public safety providing that the procedures for block adjustment are adhered to.

3. Adjustable Link Arms

Of the sixteen link arms, two are adjustable in length. The procedure for adjusting these is described in paragraph 37 of the Build-Up Instructions. When new the distance between the ends of the ball pivots for these two adjustable spaces may be of the order of 1645 mm. This will, of course, reduce if link pin/hole wear occurs. It is important to adjust these two links so that the distances between ball ends are approximately the same (i.e. within 5 mm). We emphasise that final adjustments should be made, so as to leave the link arms in tension, by tightening manually using a 1 ft (300 mm) spanner moment arm. These dimensions and torques should be checked at each Build-Up and once each month if sooner.

4. Wear of Link Arm Pins and Holes

Pin/hole wear will result in the adjustable link arms having to be shortened. The pivot blocks for the cars in these positions will, likewise, need to be adjusted. The lack of sufficient block adjustment may well be the first indication of excessive pin/hole wear. However, block wear may disguise this so a lower limit of 1620 mm between ball pivot ends corresponding to the adjustable links is considered to be the minimum permissible before remedial work is carried out to repair worn link arm pins and holes. Note that pin/hole wear is expected to be small since, apart from appreciable bearing surface area, the tightness engendered by correctly adjusting the link arms will greatly restrict pin/hole movement and fretting corrosion.

7. QUASAR COMPONENT LOCATION

1. MAIN MOTOR
2. LIFT MOTOR
3. BOBBIN $\frac{1}{2}$ DOWN MICRO SWITCH
4. BOBBIN FULLY RAISED MICRO SWITCH
5. PROGRAMMABLE LOGIC CONTROLLER BOX
6. OIL COOLER
7. BOBBIN
8. LIFT JACK CONTROL LEVERS
9. HYDRAULIC CHANGE-OVER BALL VALVES
10. OUTRIGGERS
11. TURNTABLE SUPPORT SCREW JACKS
12. MAIN POWER BOX
13. LIFT JACK
14. MAIN PACKING BLOCK SUPPORTS
15. WINCH HOOD

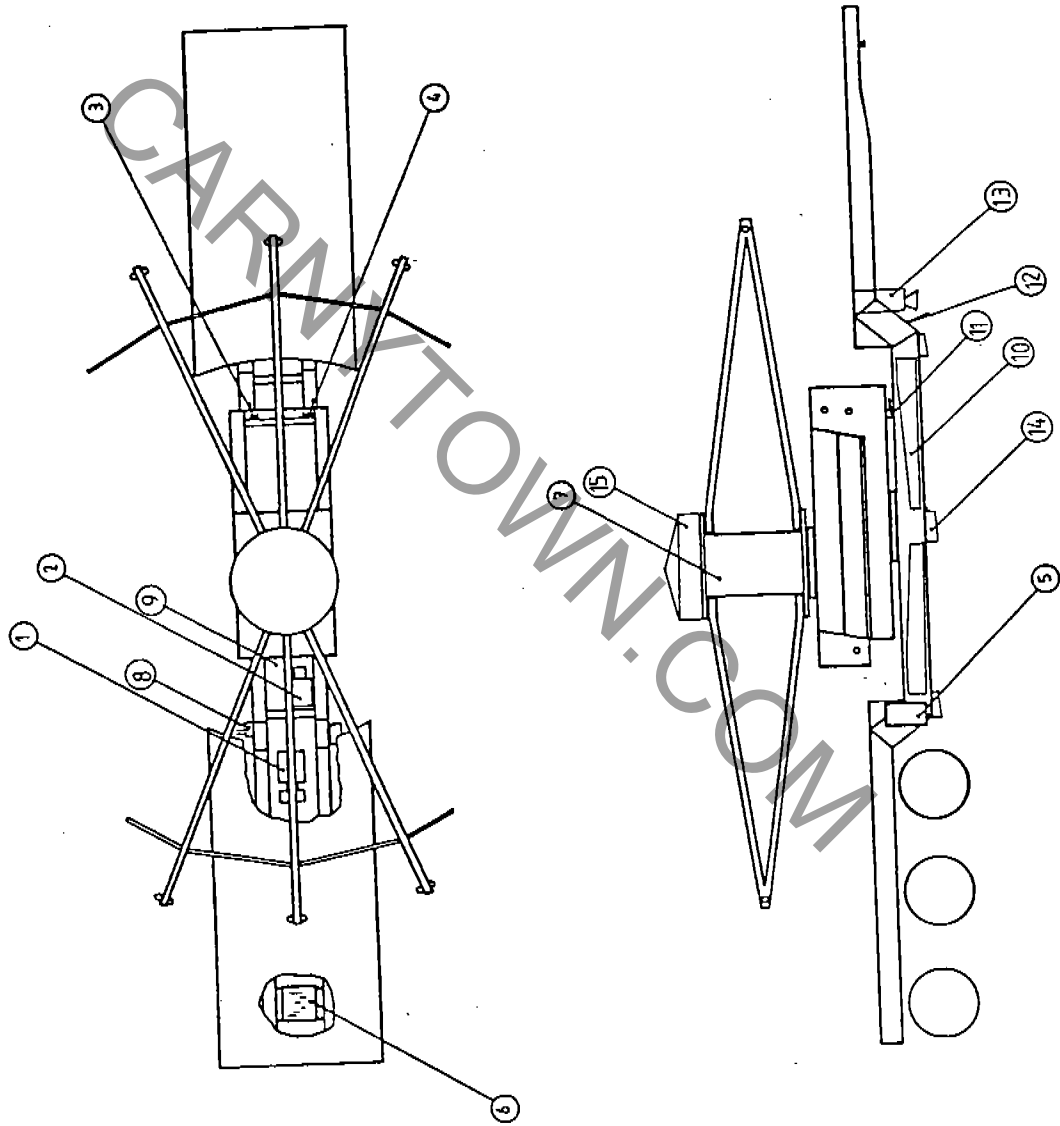

COMPONENT LOCATION

QUASAR

TWELVE MONTHLY INSPECTION AND MAINTENANCE

Every twelve months the machine must undergo a thorough examination by an appointed person who is an independent examiner suitably qualified to undertake this task and preferably having experience of non-destructive testing (N.D.T.) on steel fabrications.

To aid this examination, all weldments not visible by virtue of being masked by other structures must be made visible and reasonable access provided by appropriate dismantling, in part, or whole, of the relevant sub-assemblies.

The following are the major areas of the machine to be examined using the appropriate procedures and working to the relevant checklist in a methodical manner.

Structural Examination
Mechanical Examination
Electrical Examination
Hydraulic Examination
Pneumatic Examination
Test Procedure Examination

Any defects found, to be noted, and the implications for the integrity of the machines safe operation to be noted. Any serious structural defects must be communicated to the manufacturer at the earliest opportunity so that suitable rectification methods may be formulated and any necessary design modifications may be incorporated in future machines.

If satisfactory, sign logbook and issue inspection certificate. If not, replace unsatisfactory members and test machine as relevant checklist.

STRUCTURAL EXAMINATION

1. Check all structures for gross deformation and signs of impact.
2. Check all connecting pins and bolts for deformation, cracks, surface fretting, and correct material grade. If in doubt, **discard**.
3. Check slewing ring securing bolts for defects and correct material grade.
4. Check structures for corrosion and cracking of parent metal or weldment especially in highly stressed regions in the vicinity of securing and retaining pins or bolts. If in doubt use N.D.T. such as dye penetrant test to corroborate findings.
5. Check deck plates for damage and cracks. If in doubt, **discard**.
6. Check any timber fabric for security and damp rot. If in doubt, **discard**.
7. Check any superficial covers for security.
8. Check general level of upkeep and comment in writing.
9. Check general condition of paint finish and corrosion, i.e. superficial or deep corrosion.
10. For general correctness of assembly, with particular attention to securing pins, i.e. positioned correctly or incorrectly.

NOTE Prior to examination of 1 to 3 inclusive, degrease and clean thoroughly.

Prior to examination of 1 to 4, remove any paint or corrosion and clean thoroughly.

PNEUMATIC EXAMINATION

1. Check for leaks in cylinders or pipework.
2. Check cylinder stems for pitting or corrosion.
3. Check cylinders for retention of fluid (water).
4. Check main filter for sludge and water retention.
5. Check cylinders for jerky or intermittent operation.
6. Check cylinders for bent rods.
7. Check main reservoir for leaks and retention of water.
8. Check all valves for function, especially the exhaust section.
9. Check pressure is within design specification.

HYDRAULIC EXAMINATION

1. Check hydraulic pump for smooth operation with no signs of cavitation, noise or leakage.
2. Check shaft drive coupling for wear and security (if not close coupled).
3. Check for hose or fitting leaking and kinked or damaged pipes.
4. Check any indicators on oil filters (where provided) for evidence of sludging.
5. Check oil filler cap is not sludged and tank is open to atmospheric pressure.
6. Check oil is not heavily contaminated, sludged or carburised.
7. Check any bundy tubing is not pitted or corroded.
8. Check drive motor for jerky running or loss of power (leakage).
9. Check circuit pressure is correct and within design specifications.
10. Check settings of any relief or cross over relief valves.
11. Listen for squealing noises from valves.
12. Check control linkage for smooth consistent operation.

MECHANICAL EXAMINATION

1. Check slewing ring for roughness in operation, also check for play between races.
2. Check slewing ring for adequate greasing and any corrosion.
3. Check slewing ring drive gears for pitting, flaking and backlash.
4. Check slewing ring bolts for correct grade and torque.
5. Check passenger restraint device linkages for wear, lubrication and operation.
6. Check car slewing rings for roughness in operation and play.

TEST PROCEDURE

1. Request all parts found defective are replaced.
2. When satisfied that ride is erected in correct manner, request ride is operated unladen to maximum design speed.
3. Observe ride in unladen operating condition.
4. If satisfied, request ride be fully loaded to design specification.
5. Request ride is operated at maximum design speed.
6. Observe ride in fully laden operating condition.
7. Request ride be unloaded and re-examine as in:-

Structural Check List : 1-10

Hydraulic Check List : 1-12

Mechanical Check List : 1-15

8. If satisfactory, issue certificate and sign logbook.
9. If second examination reveals defects, downrate ride and repeat examination. Nature of defects should be communicated to manufacturer for their dissemination and appraisal.

2 YEARLY INSPECTION (NDT)

Every two years the machine should be submitted to non-destructive testing (N.D.T) of its structural components.

This should be carried out by an appointed person who is an independent examiner (as in the 12 monthly inspection) and an NDT technician certified to appropriate level in a nationally recognised certification scheme, viz:-

1. PCN - (Personal certification in N.D.T)
2. ASNT - (American Society of N.D.T)

Appropriate level for evaluation of results is level II. It is the responsibility of the appointed person to verify the technician is suitably qualified and agree the test method and technique to be used.

The appointed person must distinguish between original manufacturing flaws and ones developed during use. Also, he must distinguish between significant and insignificant flaws.

It is advised that the appointed person consults expert opinion as appropriate in the following disciplines:-

1. N.D.T.
2. Stress Analysis.
3. Welding Technology.

See checklist for N.D.T. of machines structure.

N. D. T. OF MACHINE'S STRUCTURE

RECOMMENDED METHODS OF N.D.T.

- | | | |
|----|------------------------|---------------------------------|
| 1. | Dye Penetrant Test | D.P.T. for (surface cracks). |
| 2. | Magnetic particle test | M.T. for (surface cracks). |
| 3. | Ultrasonic Testing | U.T. for (flaws and thickness). |

APPLICATION CHECK LIST

1. Check for surface cracks in parent metal at weld toes, edges of holes and any flamecut edges, in general terms in the vicinity of any stress raised.
2. Check for cracks in the surface of weldments. These should appear along the throat of the weldment.
3. Check for cracks in drive shafts in the vicinity of keyways, holes, changes in dia. or any other discontinuity.
4. For reduction in wall thickness in hollow sections caused by internal corrosion, also check for serious external corrosion (this is far less likely). This is important on thin wall sections in the vicinity of weldments and high stress areas.

NOTE Use DPT/MT for 1-3 after thorough surface preparation and degreasing of structural surface.

Use U.T. for 1-4. Remove paint and thoroughly clean coat with grease to give a good acoustic coupling.

On completion of testing, re-paint all surfaces.

2 YEARLY INSPECTION (NDT)

Every two years the machine should be submitted to non-destructive testing (N.D.T) of its structural components.

This should be carried out by an appointed person who is an independent examiner (as in the 12 monthly inspection) and an NDT technician certified to appropriate level in a nationally recognised certification scheme, viz:-

1. PCN - (Personal certification in N.D.T)
2. ASNT - (American Society of N.D.T)

Appropriate level for evaluation of results is level II. It is the responsibility of the appointed person to verify the technician is suitably qualified and agree the test method and technique to be used.

The appointed person must distinguish between original manufacturing flaws and ones developed during use. Also, he must distinguish between significant and insignificant flaws.

It is advised that the appointed person consults expert opinion as appropriate in the following disciplines:-

1. N.D.T.
2. Stress Analysis.
3. Welding Technology.

See checklist for N.D.T. of machines structure.

SPECIFIC AREAS TO BE CHECKED

1. Check main arm to ball block connection.
2. Check main arm to axle and keel plate.
3. Check car rear mounting arms.
4. Check car front slipper bar.
5. Check keel attachment brackets.

NOTE : THESE ARE ALL AREAS OF MAX STRESS

Other areas to be checked are at the discretion of the appointed person.

Machine to be dismantled as in twelve monthly inspection to allow sufficient access for the N.D.T. technician and equipment.

THE FOLLOWING INFORMATION IS REQUIRED ON N.D.T. REPORT

1. Date of examination.
2. Technicians name and qualification.
3. Details of N.D.T. technique.
4. Parts examined and which elements comprised part of sample.
5. Parts unavailable for examination, if any.
6. Results of examination.

ALL REPORTS TO BE KEPT AVAILABLE BY THE RIDE OWNER

QUASAR (A.R.M. ENGLAND)

Safety Check

1. Check that all lap bar bolts are tight and that all catches are operating correctly. Note that it is possible for the catch springs to break as a result of fatigue (ARM Part No. Q-107). DO NOT USE ANY CAR ON WHICH THE LAP BAR DOES NOT LOCK AS INTENDED.
2. Each car incorporates two wire restraint bonds attaching to the adjacent main radial arms. Although normal operation should not cause damage to these, they should be visually checked daily for signs of loose fixing bolts, broken wires, or other damage. ANY DAMAGED WIRE RESTRAINT BOND SHOULD BE REPLACED IMMEDIATELY. (ARM Part No. Q-106).
3. To check the operation of the car motion dampers pull each car outwards until the lap bar lock reaches waist height. Upon releasing the car it should fall back to its rest position without vibration. If this is unsatisfactory the motion dampers (ARM Part No. Q-103) must be individually checked. ON NO ACCOUNT OPERATE THE RIDE UNTIL THIS TEST CAN BE PASSED BY ALL SIXTEEN CARS.
4. Note that all pins are retained by clips. A daily visual inspection should be made to ensure that all clips are present. The pins locating the car motion dampers should be directed such that each clip faces the car interior.

QUASAR (A.R.M. ENGLAND)

- 5) Due to a settling effect after some hours work IT IS ESSENTIAL that the slewing ring bolts of a new QUASAR are retightened to a torque of 80 Nm. This should be carried out every two weeks for the first two months and thereafter once every three months.
6. Every car is mounted on two spherical balls through blocks of low friction material. These blocks should have a considerable wear life. A visual inspection should be carried out every month to detect any abnormal or excessive block wear or splitting. Corrective action will depend upon the symptoms.
7. One of the effects of block wear is that some car end float may develop between the spherical balls. Having inspected the blocks (in 1 above), any end float should be adjusted out when the car is remounted. If this is not done then block wear will be accelerated. Adjustment is carried out as described in the Build-Up Procedure (page 10).

QUASAR (A.R.M. ENGLAND)

8. All slewing ring fixing bolts should be checked to ensure that the tightening torque of 860 Nm still holds. Note that this must be carried out every two weeks for the first two months when your Quasar is new.
9. The wire car restraint bonds attach to the ends of the main radial arms by means of a bolt bearing in three plates. A visual inspection should be made for hole or bolt wear. In normal circumstances wear should be negligible.
10. All pins and pin holes in the main arms, link arms and bobbin should be checked for signs of wear.
11. Check the car pivot balls for signs of scoring. This may occur if dirt or grit inclusions penetrate into the blocks of friction material. The importance of checking the cleanliness of the blocks at build-up is therefore emphasised. Scored ball pivots can cause accelerated block wear. In the case of a severely scored ball pivot consideration will need to be given to replacement. (ARM Part No. Q-105).

QUASAR (A.R.M. ENGLAND)

12. The car motion dampers should be visually checked weekly in the region of the piston rod oil seals for loss of oil. Although these seals should have a considerable life, any unusual ingress of dirt particles etc. may cause seal damage, oil leakage, and resultant loss of damper function. A DAMPER MUST BE REPLACED IMMEDIATELY WHEN OIL LOSS BECOMES EVIDENT. (ARM Part No. Q-103).

13. Each car motion damper is attached to its radial arm via a rubber bush in the cylinder eye. This bush should be checked for damage or loss of rubber. They may need periodic replacement (ARM Part No. Q-101). The self-locking nut which retains the bush should not be tightened far enough to compress the rubber as this accelerates wear. At the other end of the motion damper

QUASAR (A.R.M. ENGLAND)

i. Safety Check:

- A. Check that all lap bar bolts are tight and that all catches are operating correctly. Note that it is possible for the catch springs to break as a result of fatigue (A.R.M. Part No. Q-107), DO NOT USE ANY CAR ON WHICH THE LAP BAR DOES NOT LOCK AS INTENDED.
- B. Each car incorporates two wire restraint bonds attaching to the adjacent main radial arms. Although normal operation should not cause damage to these, they should be visually checked daily for signs of loose fixing bolts, broken wires, or other damage. ANY DAMAGED WIRE RESTRAINT BOND SHOULD BE REPLACED IMMEDIATELY (A.R.M. Part No. Q-106).
- C. To check the operation of the car motion dampers pull each car outward until the lap bar lock reaches waist height. Upon releasing the car it should fall back to its rest position without vibration. If this is unsatisfactory the motion dampers (A.R.M. Part No. Q-103) must be individually checked. ON NO ACCOUNT OPERATE THE RIDE UNTIL THIS TEST CAN BE PASSED BY ALL SIXTEEN CARS.
- D. Note that all pins are retained by clips (R-Keys). A daily visual inspection should be made to ensure that all clips are present. The pins locating the car motion dampers should be directed such that each clip faces the car interior.
- E. Due to a settling effect after some hours work IT IS ESSENTIAL that the slewing ring bolts of a new QUASAR are retightened to a torque of 860Nm. This should be carried out every two weeks for the first two months and thereafter once every three months.
- F. Every car is mounted on two spherical balls through blocks of low friction material. These blocks should have a considerable wear life. A visual inspection should be carried out every month to detect any abnormal or excessive block wear or splitting. Corrective action will depend upon the symptoms.

- G. One of the effects of block wear is that some car end float may develop between the spherical balls. Having inspected the blocks (in A above), any end float should be adjusted out when the car is remounted. If this is not done then block wear will be accelerated. Adjustment is carried out as described in the Build-Up Procedure (page 10).
- H. All slewing ring fixing bolts should be checked to ensure that the tightening torque of 860 Nm still holds. Note that this must be carried out every two weeks for the first two months when your Quasar is new.
- I. The wire car restraint bonds attach to the ends of the main radial arms by means of a bolt bearing in three plates. A visual inspection should be made for hole or bolt wear. In normal circumstances wear should be negligible.
- J. All pins and pin holes in the main arms, link arms, and bobbin should be checked for signs of wear.
- K. Check the car pivot balls for signs of scoring. This may occur if dirt or grit inclusions penetrate into the blocks of friction material. The importance of checking the cleanliness of the blocks at build-up is therefore emphasized. Scored ball pivots can cause accelerated block wear. In the case of a severely scored ball pivot consideration will need to be given to replacement. (A.R.M. Part No. Q-105)
- L. The car motion dampers should be visually checked weekly in the region of the piston rod oil seals for loss of oil. Although these seals should have a considerable life, any unusual ingress of dirt particles, etc. may cause seal damage, oil leakage, and resultant loss of damper function. A DAMPER MUST BE REPLACED IMMEDIATELY WHEN OIL LOSS BECOMES EVIDENT. (A.R.M. Part No. Q-103).
- M. Each car motion damper is attached to its radial arm via a rubber bush in the cylinder eye. This bush should be checked for damage or loss of rubber. They may need periodic replacement (A.R.M. Part No. Q-101). The self-locking nut which retains the bush should not be tightened far enough to compress the rubber as this accelerates wear.

- N. Check to see that hydraulic jacks have been released before the ride operates.
- O. Check holding brakes - when ride comes to a stop (loaded) cars should not drift.
- P. Service Bulletin: Qua/03/002 and Qua/03/001

CARNYTOWN.COM

CARNYTOWN.COM

SERVICE BULLETIN QUA/03/001

(QUASAR AMUSEMENT RIDE)

SEPTEMBER 1988

In response to reports of cracking in the vicinity of weldments on the Quasar lower lifting frame, it has been deemed prudent in the interests of public safety to initiate remedial action.

After examination and assessment it has been concluded that the cracking is fatigue initiated due to the presence of geometrical discontinuities in the vicinity of the tensile fibres of the main side members and forward crossmember.

These discontinuities in the form of weldments and square profiled pipe slot produce local stress concentrations and initiate cracks in the tensile fibres.

To obviate and prevent further occurrence of these phenomenon the following modifications to the lower lifting frame are to be carried out.

1. Bracing gussets to connect side members, crossmembers and lower plate. This will reduce moment arm on sidemembers and increase torsional stiffness, thus reducing stress levels and stress range in this vicinity.
2. Stiffening plate on underside to lower neutral axis and increase section modulus on tensile flange of sidemembers in the XX plane. This will also increase torsional stiffness and bending stiffness in the YY plane.
3. Modification to the profile of pipe slot in forward crossmember by radiusing the ends of slot, thus removing the local stress concentration present at the upper square corners of the original slot.

These modifications are designed to reduce the stress ranges incurred by the lower frame members when in bend and axial tension. This will greatly increase the number of loading events that may be sustained by the structure and thus increase its useful life in fatigue terms.

It was decided to position the stiffening plate on the underside of the structure, i.e. the compression zone because there is a zero risk of initiating any further cracks in the vicinity of its weldments. It is also bad practice to cover up existing cracks because of the risk of them propagating unseen below this plate. Also there is a risk of initiating further cracks in the vicinity of the new weldments, especially at the ends of intermittent welds.

For the above reasons it was deemed prudent to position the stiffening plate on the underside while recognising that it is less effective in the tensile zone than would be the case if it were positioned on top of the structure.

The above modifications are to be carried out on all rides not later than five years after commencement of operational use.

MODIFICATION PROCEDURE

1. Repair any existing cracks in the top of sidemembers by grinding out to full depth and butt welding with a full penetration single 'V' butt weld.

These welds to have a root run by manual metal arc using a 5mm low hydrogen electrode. Remainder of weld may be by manual metal arc or M.I.G.

After completion of weld, grind down flush with surface of member giving a smooth crack free surface.

2. Repair any existing cracks in crossmember located at the top corners of pipe slot by drilling a 10mm diameter hole at the upper end of cracks as depicted on page 6. No further action is required.
3. Modify shape of pipe slot as depicted on page 6. Remove any drag lines from flame cutting and grind smooth.
Weld pipe slot flange part no. QUA/01/4 into position as depicted on pages 7 and 8.
4. Weld lower stiffening plate into position. Weld type as depicted on pages 11 and 12.
5. Weld gussets in the vicinity of pipe slot into position, part no. QUA/01/2 and QUA/01/3. Weld joint type and corner detail as depicted on pages 5 and 12. Weld remainder of gussets in position. Part No. QUA/01/1.
6. The weld connecting the sideplates to the top of sidemembers is to be ground flush with top surface of sidemembers for the last 150mm of its length. See pages 10 and 12.

The vertical weld connecting end of sideplates to side of sidemembers is to be ground out to give a weld prep for the first 150mm of its length. Weld type and corner detail as depicted on pages 10 and 12.

ORIGINAL CONSTRUCTION

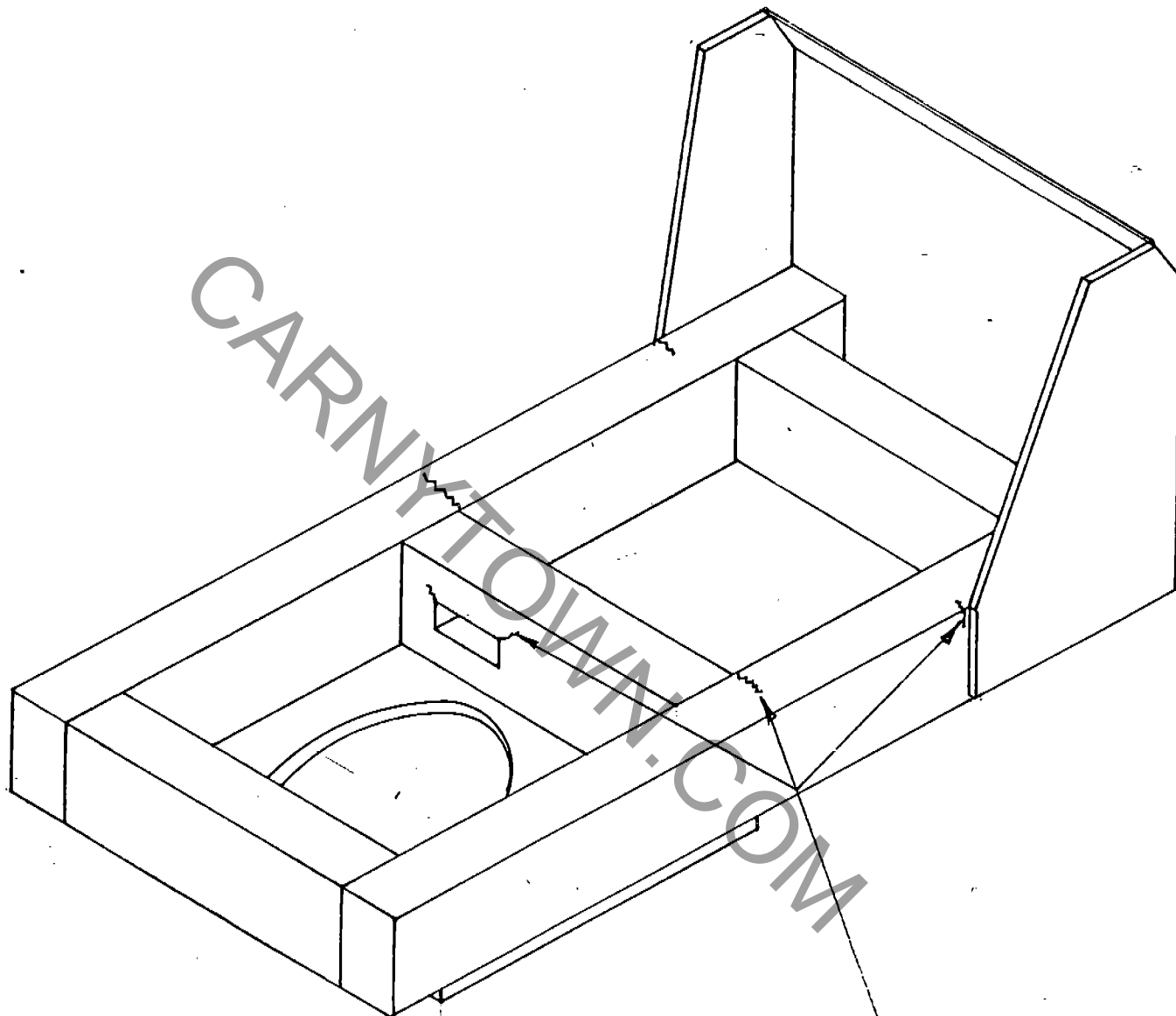

POTENTIAL CRACK LOCATION

MODIFIED CONSTRUCTION

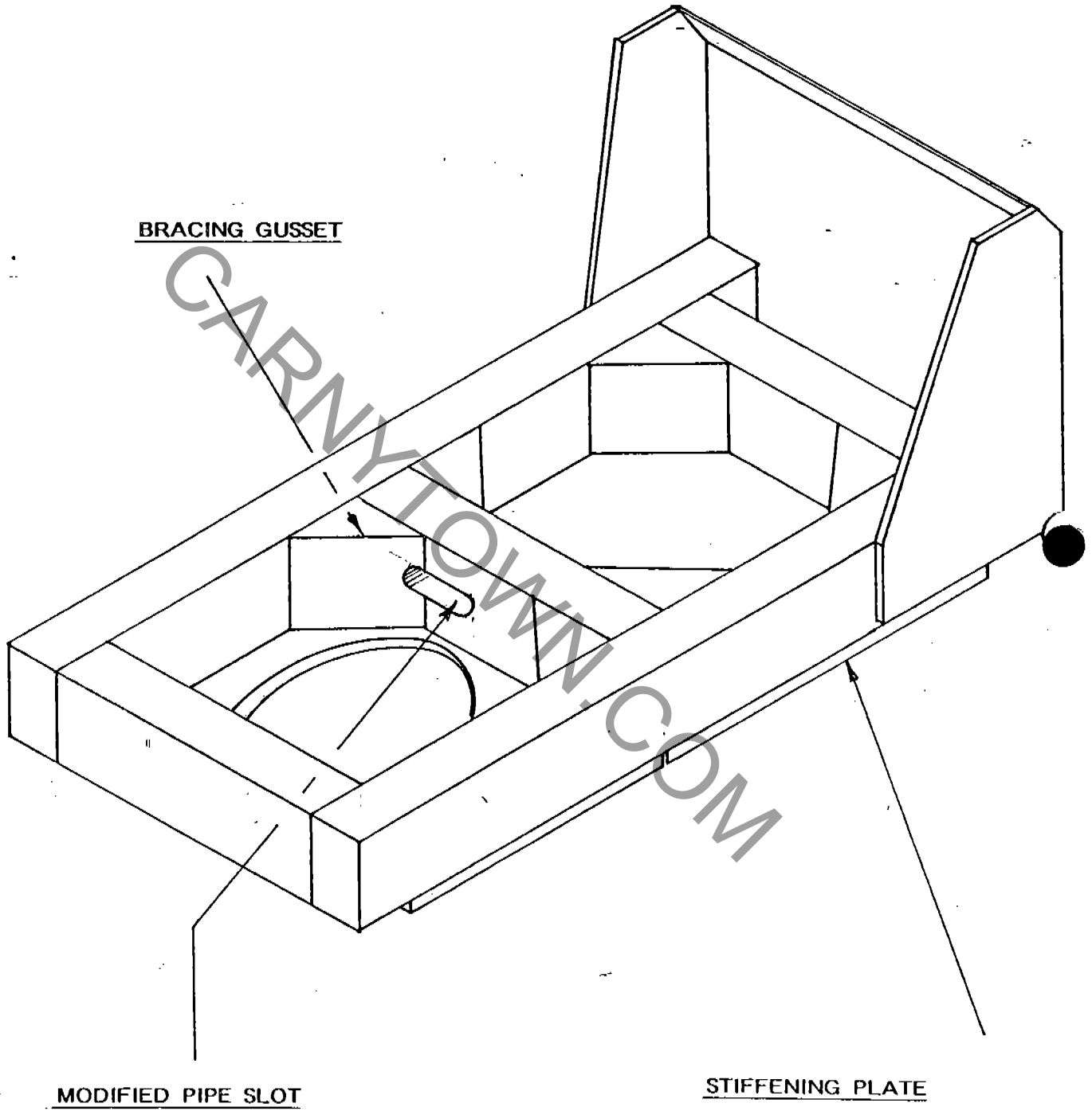

PIPE SLOT DETAIL

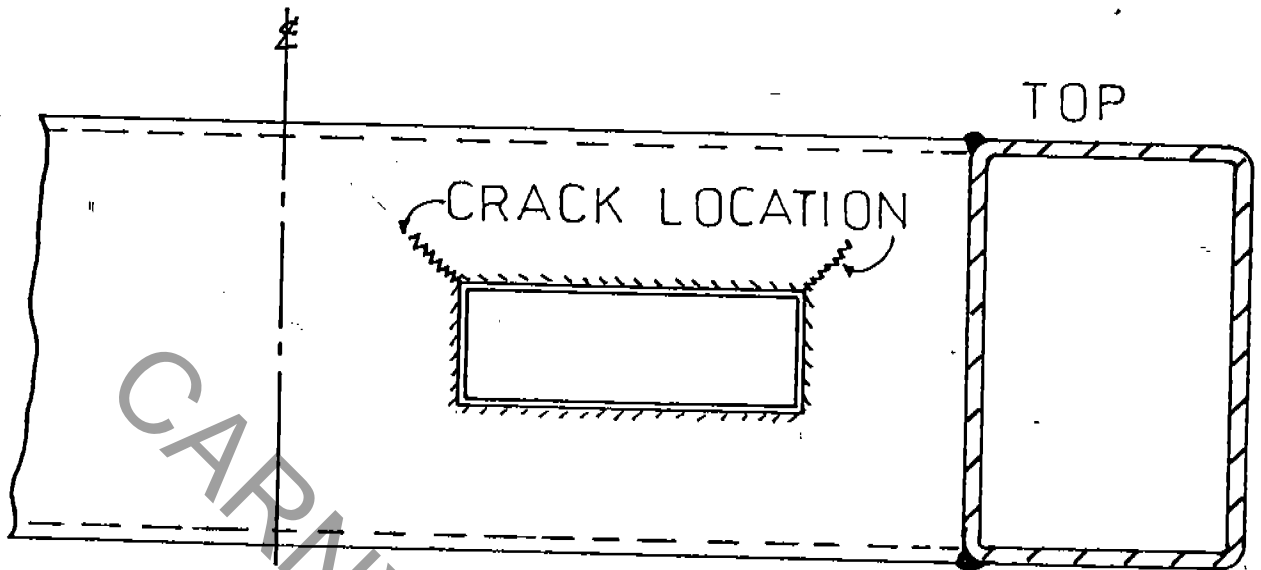

ORIGINAL PIPE SLOT

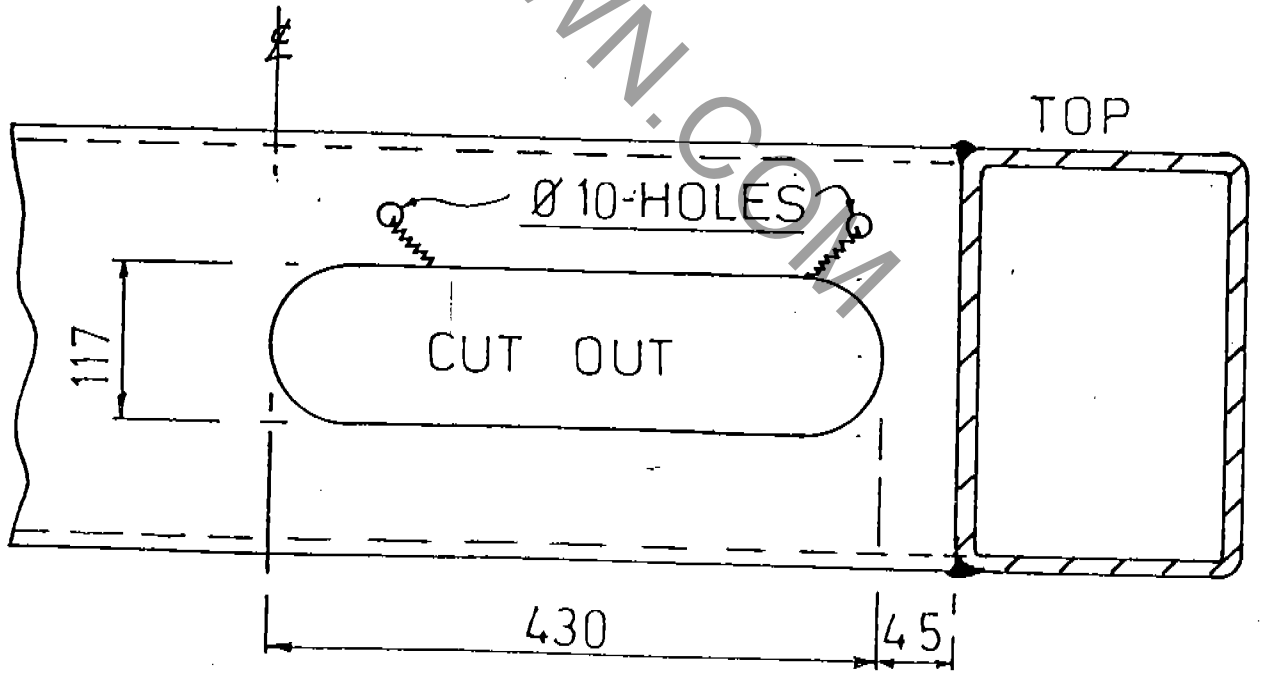

MODIFIED PIPE SLOT

MODIFIED PIPE SLOT

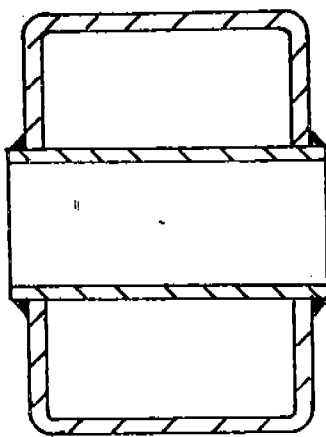
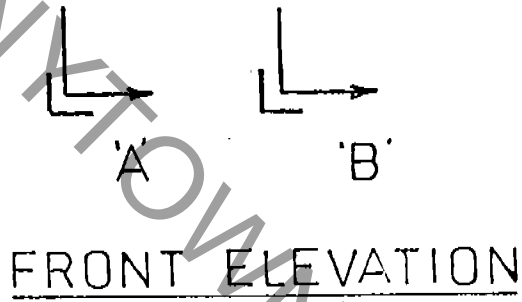
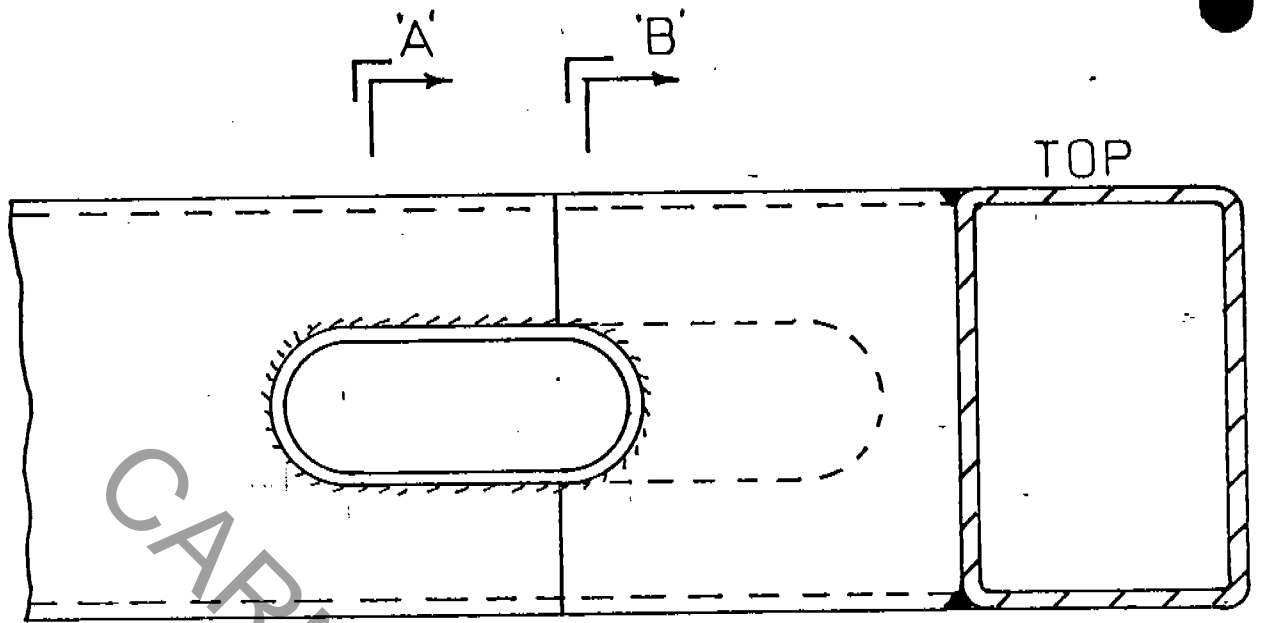

SECTION A-A

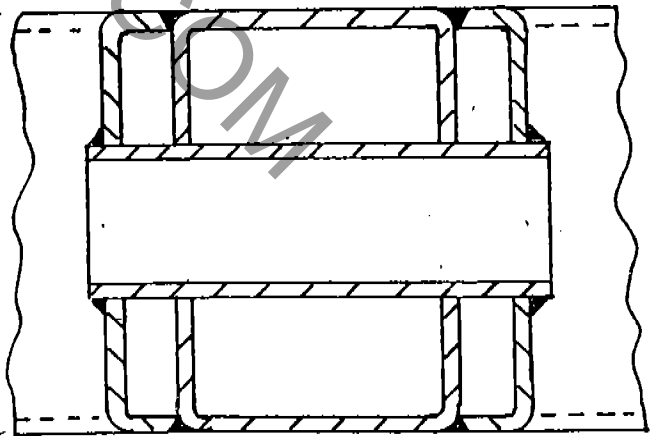

SECTION B-B

MODIFIED PIPE SLOT

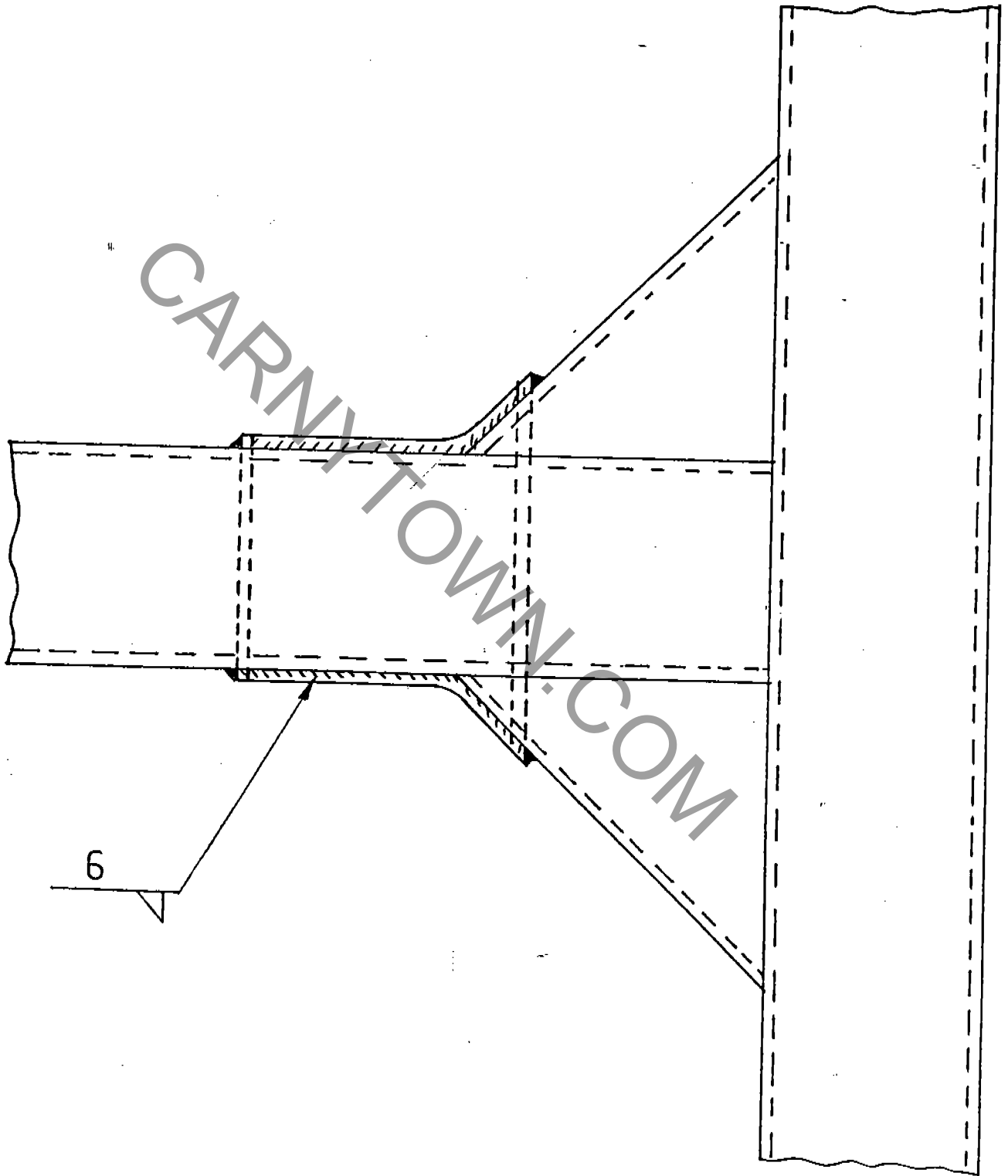

PLAN ON PIPE SLOT

WELDING DIAGRAM (LOWER FRAME)

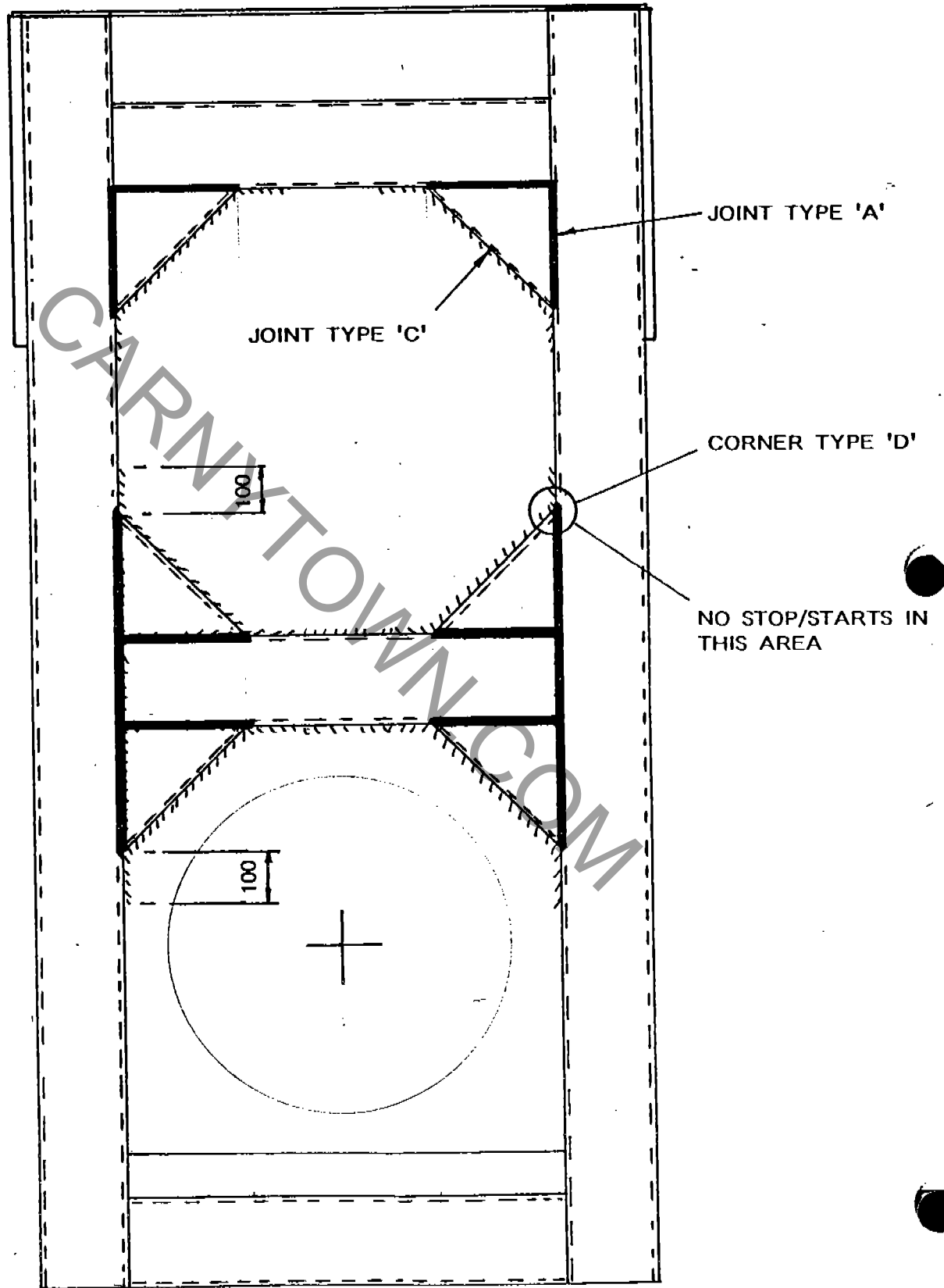

PLAN

WELDING DIAGRAM (SIDE PLATE)

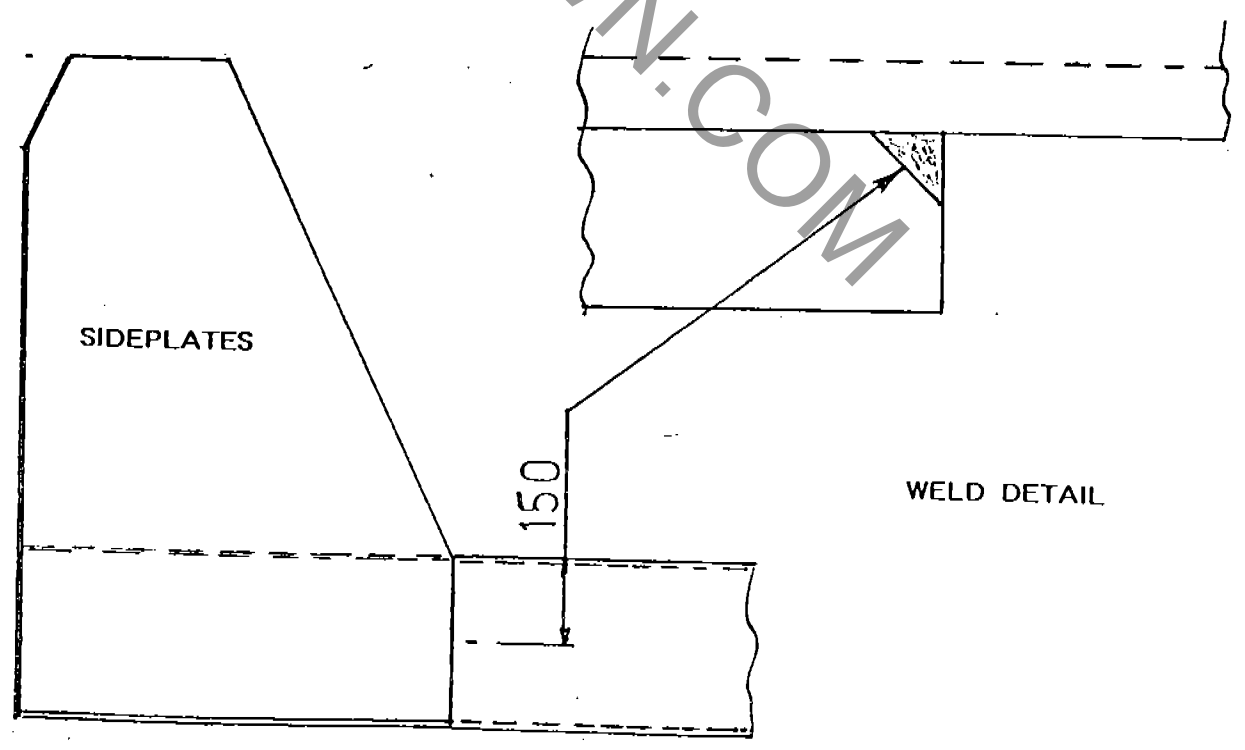
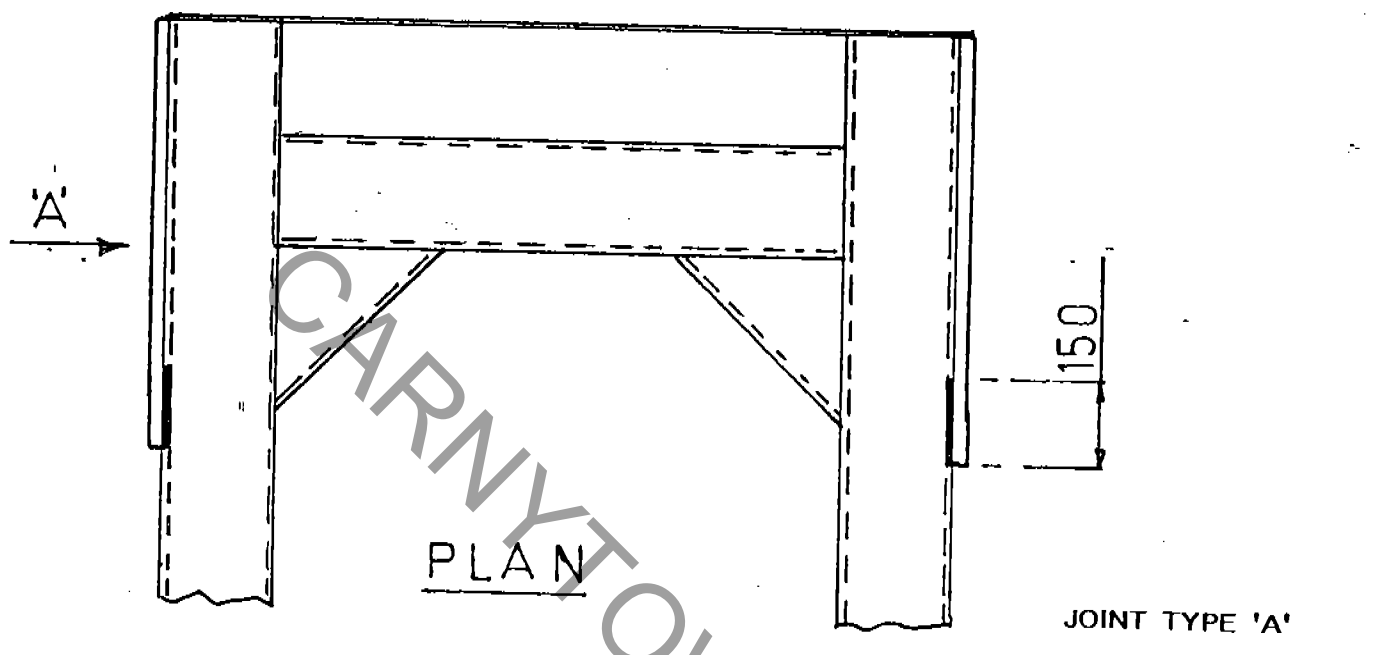

VIEW ON ARROW 'A'

WELDING DIAGRAM (LOWER FRAME)

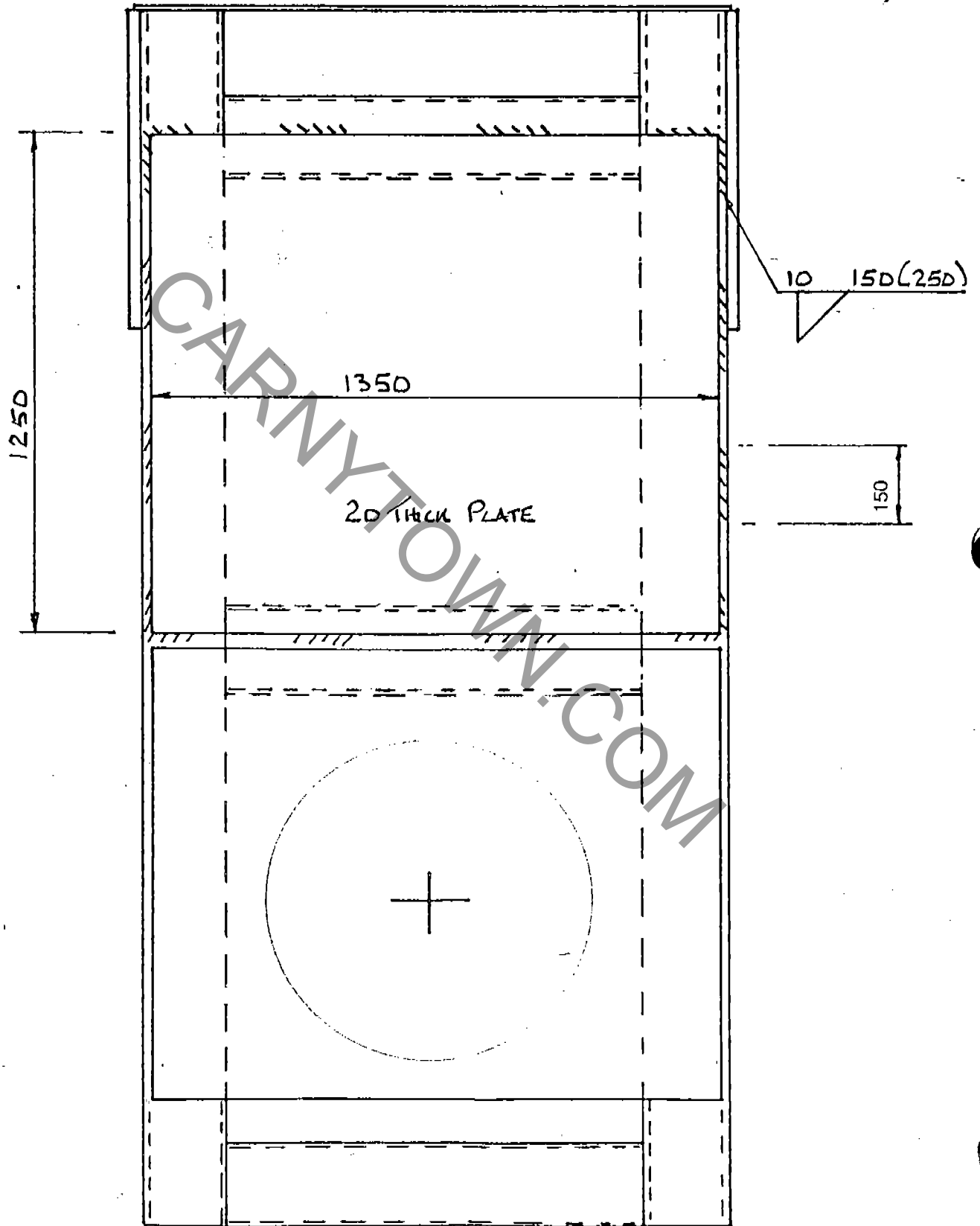

VIEW ON UNDERSIDE

WELD TYPES

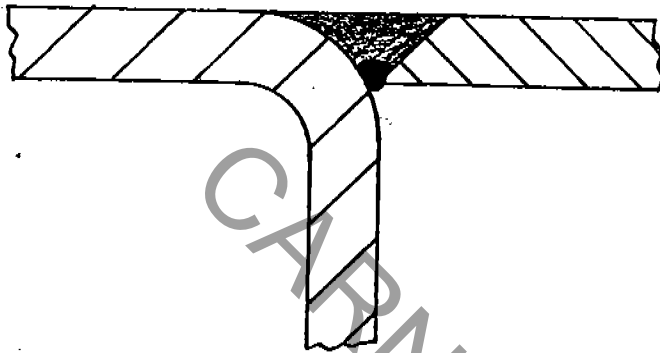

JOINT TYPE 'A'

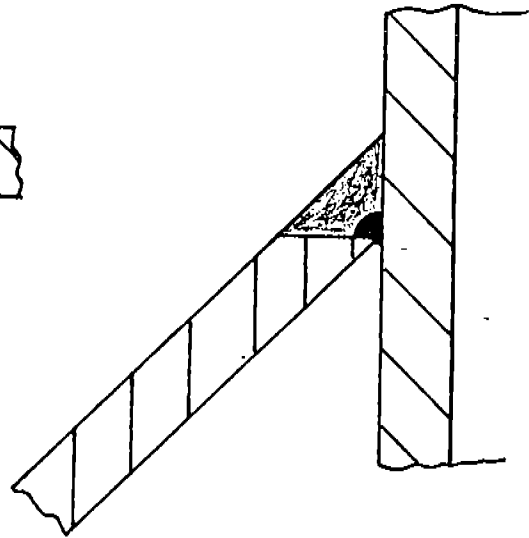

JOINT TYPE 'B'

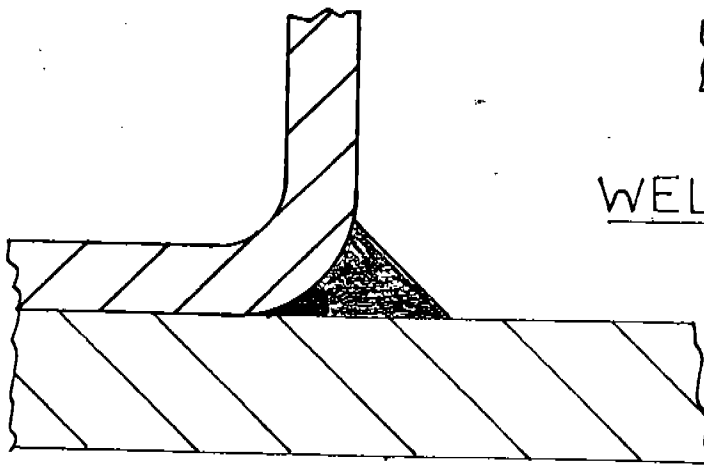

JOINT TYPE 'C'

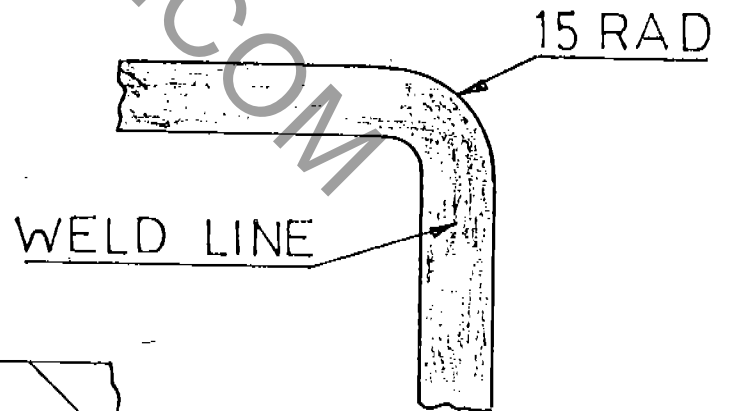

CORNER TYPE 'D'

MAKE FROM 300x200x10 R.H.S.

WELD PREP TOP ONLY

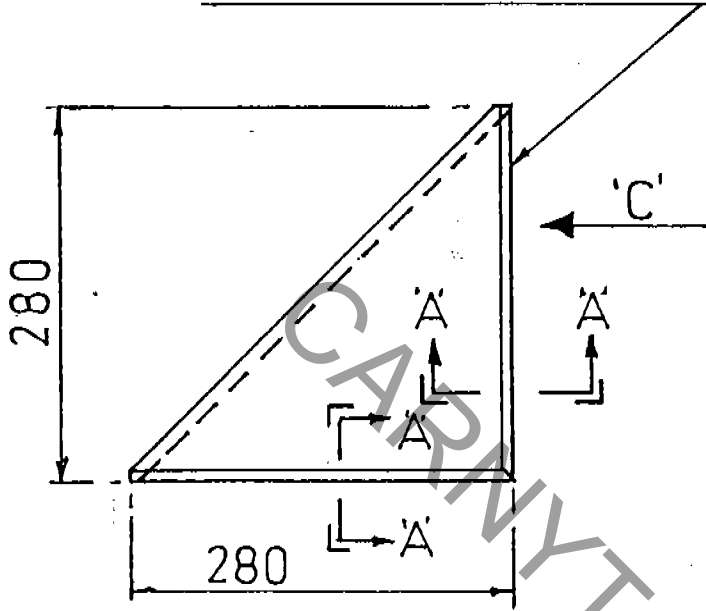

PLAN

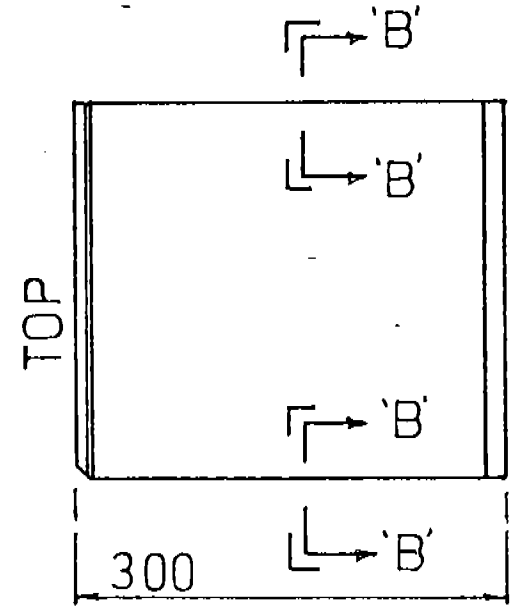

VIEW ON ARROW 'C'

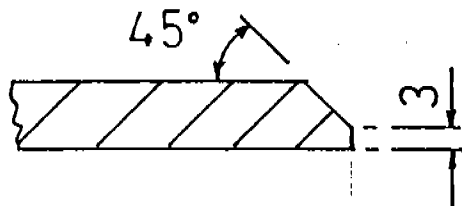

SECTION A-A

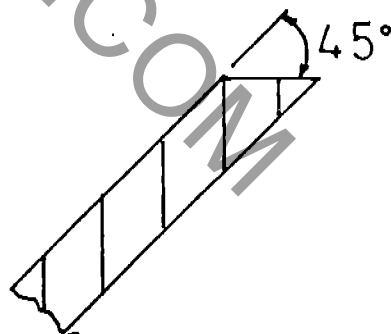

SECTION B-B

MAKE FROM PART NO QUA/01/1

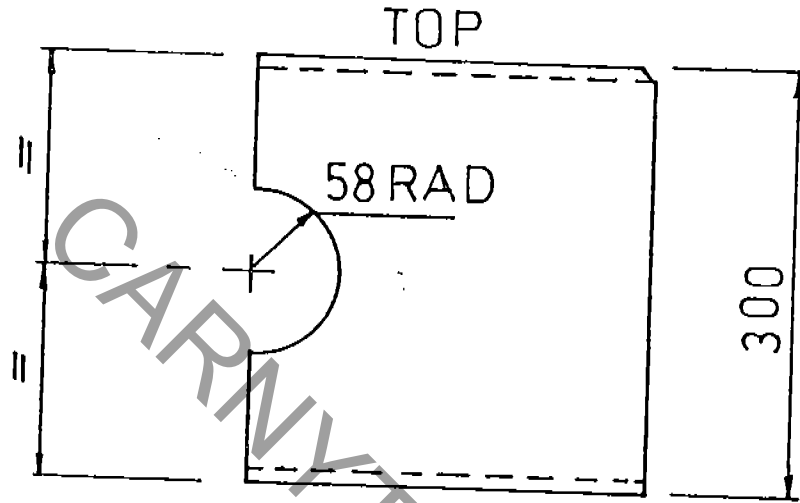

FRONT ELEVATION

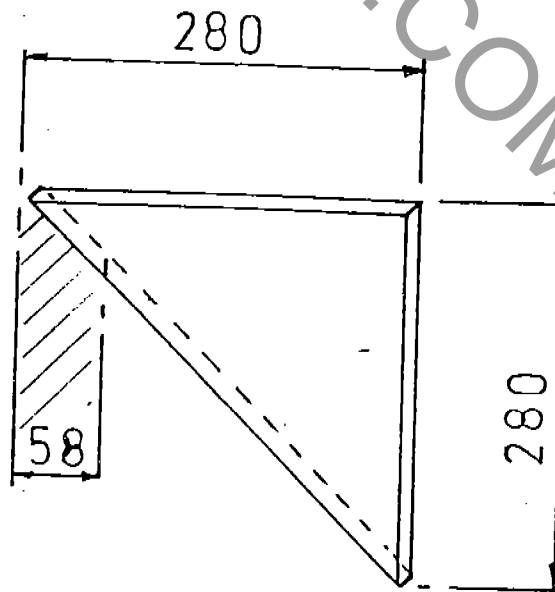

PLAN

GUSSET. PART NO. QUA/01/2. LH - 1 OFF

GUSSET. PART NO. QUA/01/3. RH - 1 OFF

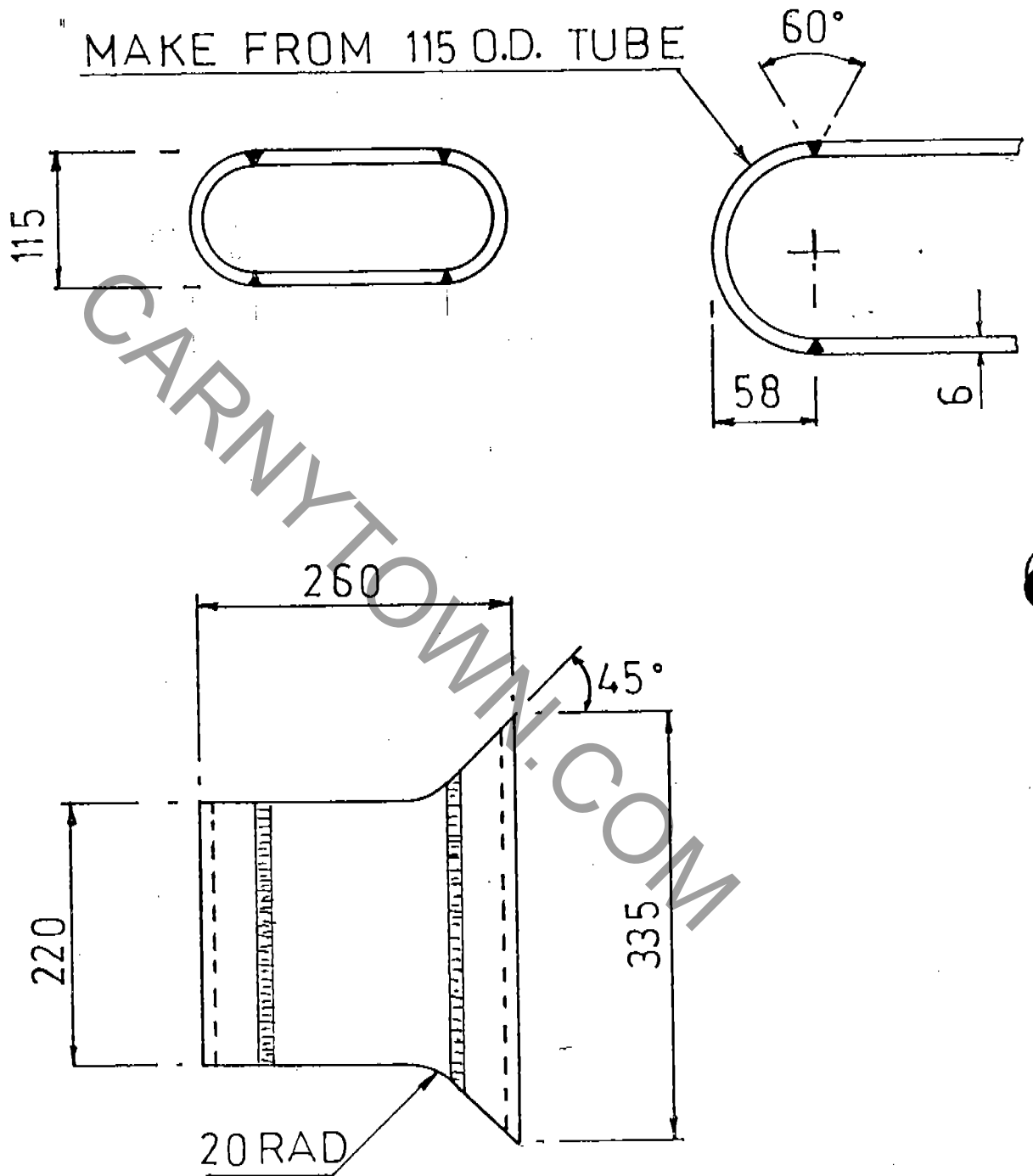

PIPE SLOT FLANGE. PART NO. QUA/01/4 - 1 OFF

SERVICE BULLETIN QUA/03/002

(QUASAR AMUSEMENT RIDE)

SEPTEMBER 1988

In response to report of cracking in the vicinity of weldments on the trailer main longitudinal members and top mounting plate, it has been deemed prudent in the interests of public safety to initiate remedial action.

After examination and assessment it has been concluded that the cracking is fatigue initiated. The loading spectrum on the trailer is very complex because when in travelling mode the trailer will be subject to stress ranges of varying magnitude and quantity. This will depend on the road surface quality and the number of miles travelled per annum. The former is impossible to evaluate without resorting to strain gauge analysis.

The loading spectrum when operational may be assessed with some accuracy and the loadings on the trailer imposed by the outrigger feet and pads appear to be significant in fatigue terms.

The picture is further complicated by their being two types of trailer construction, viz Type 1 with cranked main longitudinal members and Type 2, with straight members. The cranked version gives most cause for concern because the members are cut, bent and then welded which places a weldment at right angles to the stress lines in the tensile zone. This weldment then initiates cracks on the underside of the main members which propagate outwards and upwards.

To obviate and prevent further occurrence of these phenomenon the following modifications to the trailer are to be carried out.

1. Bracing strap to be fitted on underside of main members.
2. Bracing member fitted vertically between top and bottom plate and connected to side of main members.

These modifications are designed to reduce the stress ranges incurred by the trailer main longitudinal members and reduce the bending moment on the top plate in addition to providing a greater weld area.

On the cranked version of trailer the bracing strap will need to be cranked to follow the contour of the main longitudinal members.

The above modifications are to be carried out on all rides not later than five years after commencement of operational use.

MODIFICATION PROCEDURE

1. Repair any existing cracks by grinding out to full depth and butt welding with a full penetration single 'V' butt weld.

These welds to have a root run by manual metal arc using a 3mm low hydrogen electrode. Remainder of weld may be manual metal arc or MIG.

After completion of weld, grind down flush with surface to give a smooth crack free surface.

2. Cut out a 160mm wide section of bottom plate above both main members to allow bracing strap to pass along surface of main members - see Page 6 .

Weld prep edges of bottom plate and bracing strap as depicted on Page 6 . Weld bracing strap to underside of main members then weld bottom plate to bracing strap as depicted on Page 6 .

3. Weld bracing member between top and bottom plates and side of main members as depicted on Page 6

MODIFICATION PROCEDURE

1. On cranked type trailer, remove all weld bridging plates positioned on underside of trailer. Repair any existing cracks by grinding out to full depth and butt welding with a full penetration single 'V' butt weld.

These welds to have a root run by manual metal arc using a 3mm low hydrogen electrode. Remainder of weld may be manual metal arc or MIG.

After completion of weld, grind down flush with surface to give a smooth crack free surface.

2. Weld wedge plates to underside of main members butting angled end up to bottom plate and welding together.
3. Position bracing strap over bottom plate. Weld strap to bottom plate and bend down to follow contour of wedge plates. Weld strap to wedge plates and main members. See Pages 7 and 8.

ORIGINAL CONSTRUCTION (STRAIGHT TYPE)

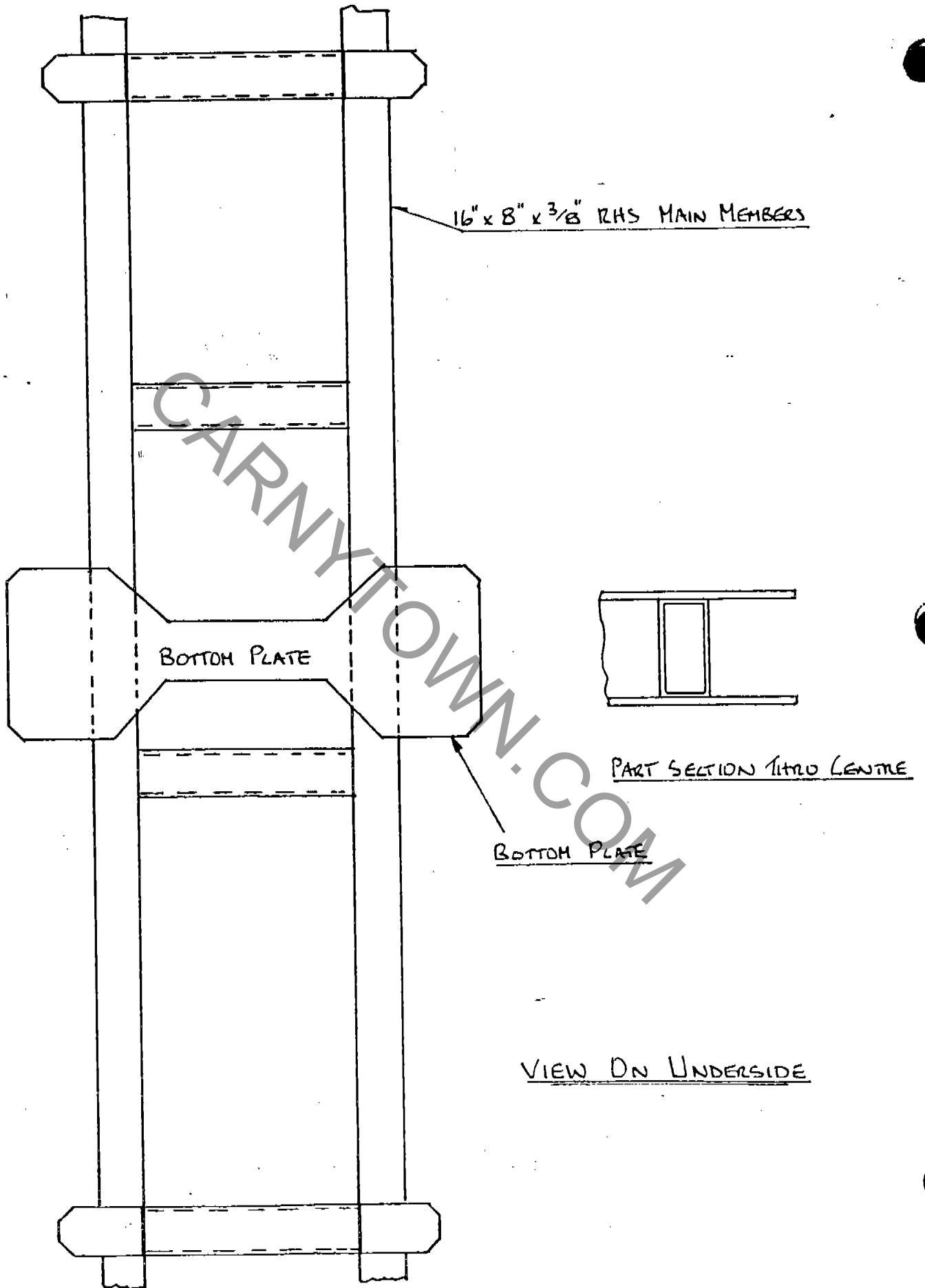

ORIGINAL CONSTRUCTION (CRANKED TYPE)

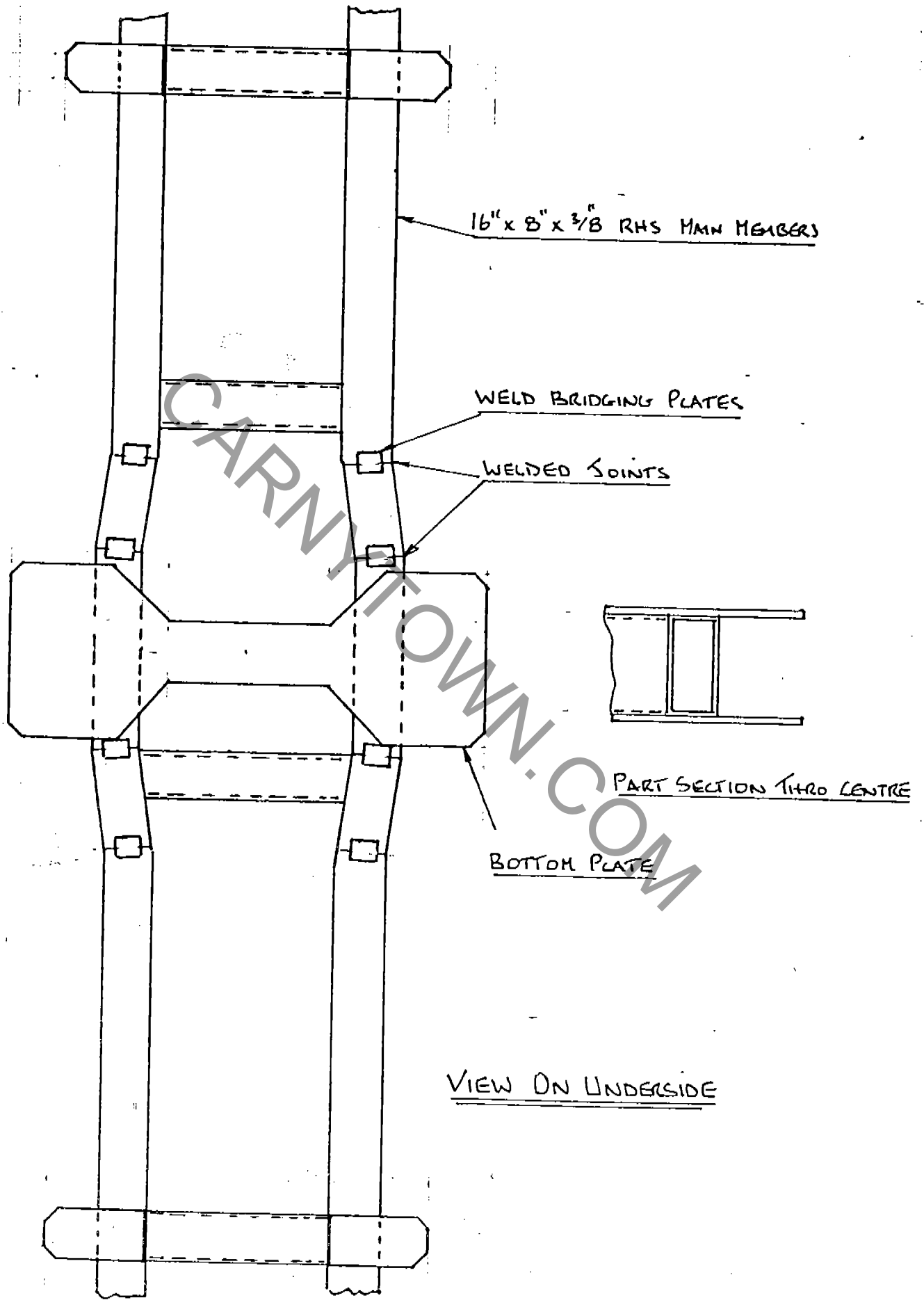

VIEW ON UNDERSIDE

MODIFIED CONSTRUCTION (STRAIGHT TYPE)

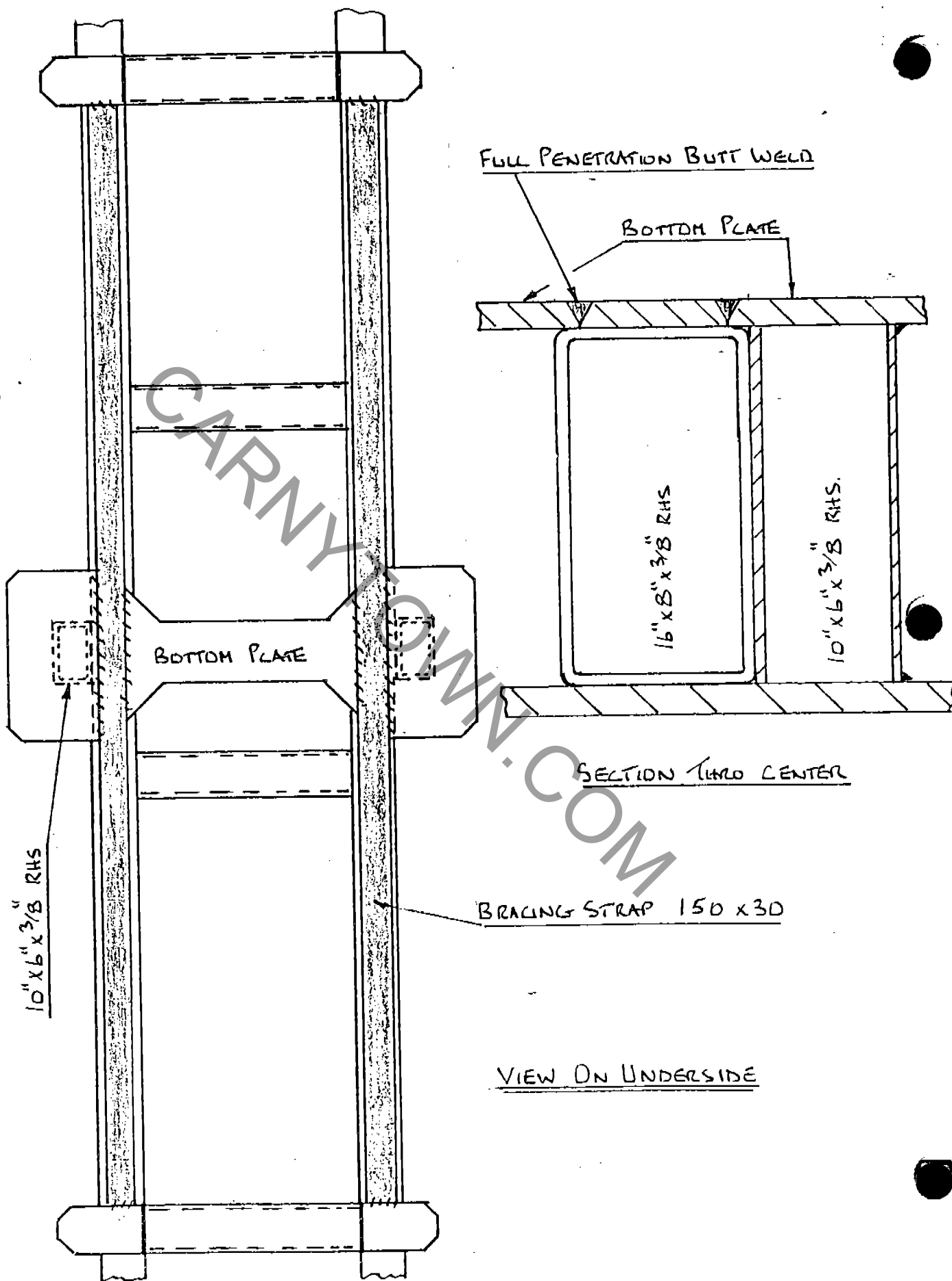

MODIFIED CONSTRUCTION (CRANK TYPE)

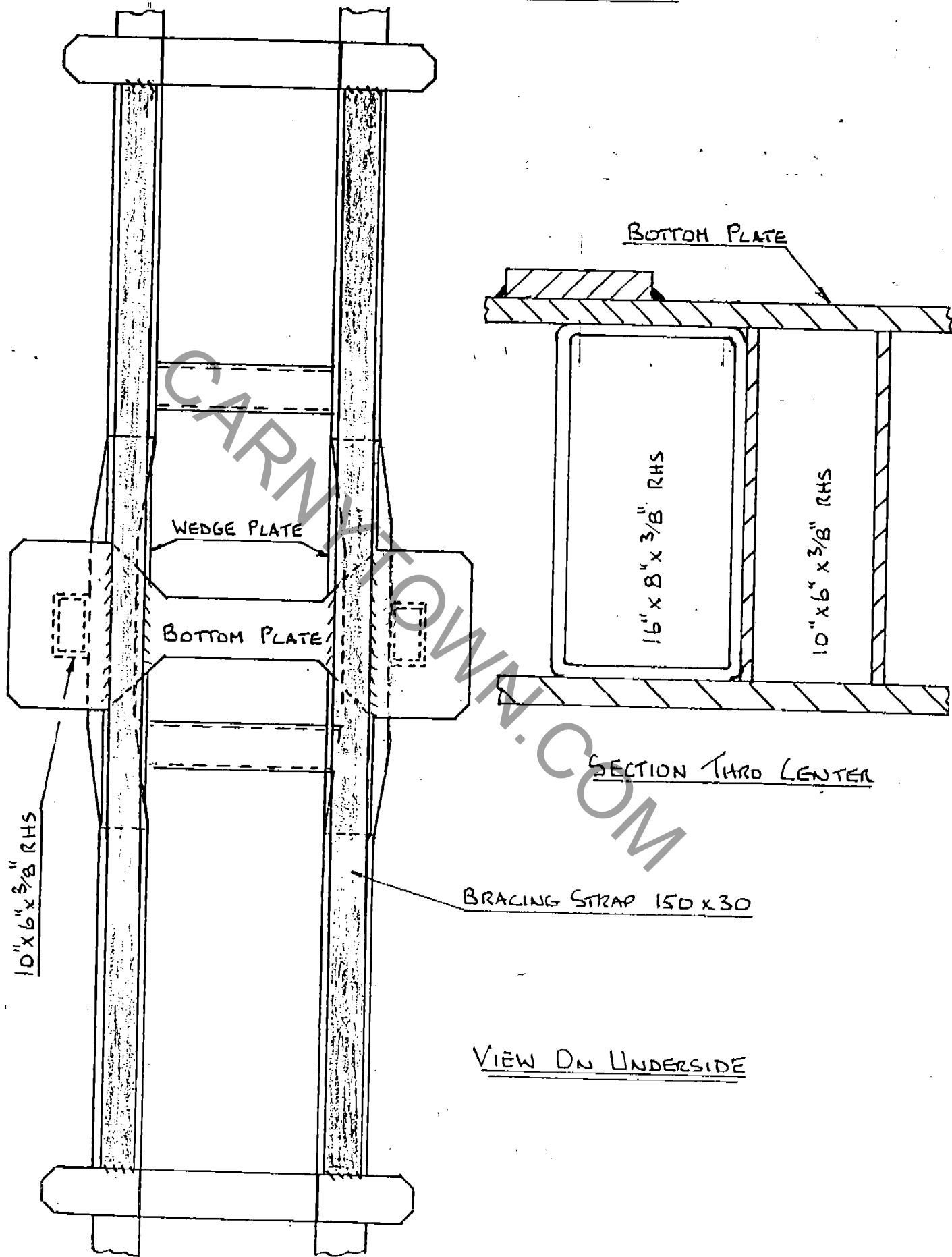

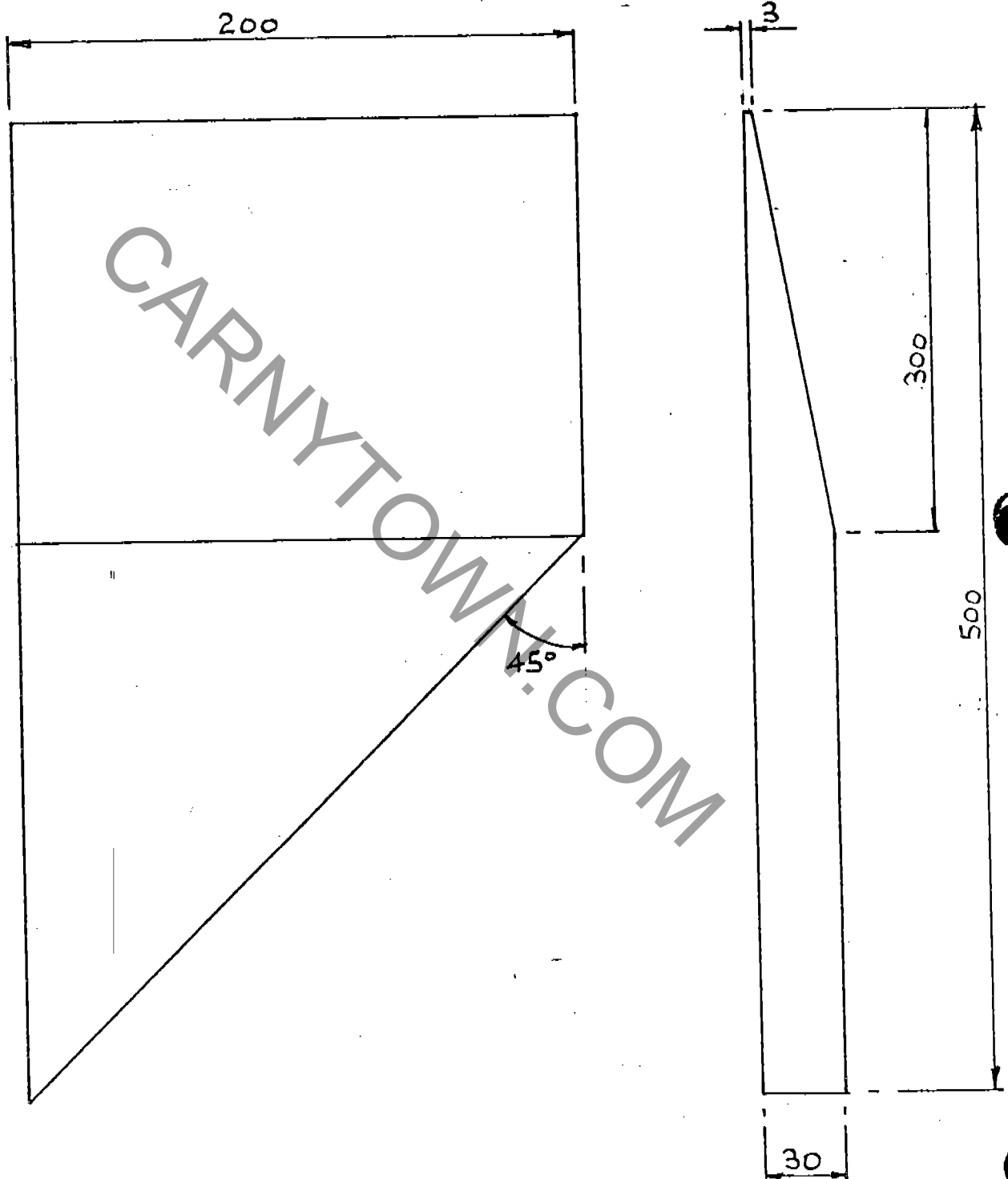

DETAIL OF WEDGE PLATE. MAKE IN PAIRS 2-LH & 2 R.H.
MAT^L M.S. TO BS4360-G43A OR EQUIVALENT