

MFG: ALLEN HERSCHELL
RIDE: MERRY GO ROUND
WITH FLUID DRIVE

Merry-Go-Rounds

After 79 years of development, the Allan Herschell Merry-Go-Round with new features and steel construction is the smoothest operating, most durable, and fastest-to-erect Merry-Go-Round ever built. It is a sensational success, having received praise from carnival men and park operators all over the country. F. E. Gooding, the famous carnival operator of Columbus, Ohio, bought three in nine months to add to

the 100 rides his company already owned.

In the new Merry-Go-Round, mud sills and sweeps are of steel, thus increasing the already long life of AH Merry-Go-Rounds. The drive is now chain-and-sprocket and, because it is self-aligning, requires less skilled help for setting and dismantling. Center pole is quickly and safely raised by only two men with the new hand winch and steel pole. (see opposite page). Electric brake automatically stops ride in one revolution.

More Allan Herschell Merry-Go-Rounds are in use today than any other make. Many have been in service for 50 years—or longer—and are delivering faithful and profitably for their owners today because Allan Herschell builds them better to last longer, with less maintenance. Now, with new materials and improved manufacturing methods, the Allan Herschell Merry-Go-Round is a better investment than ever!

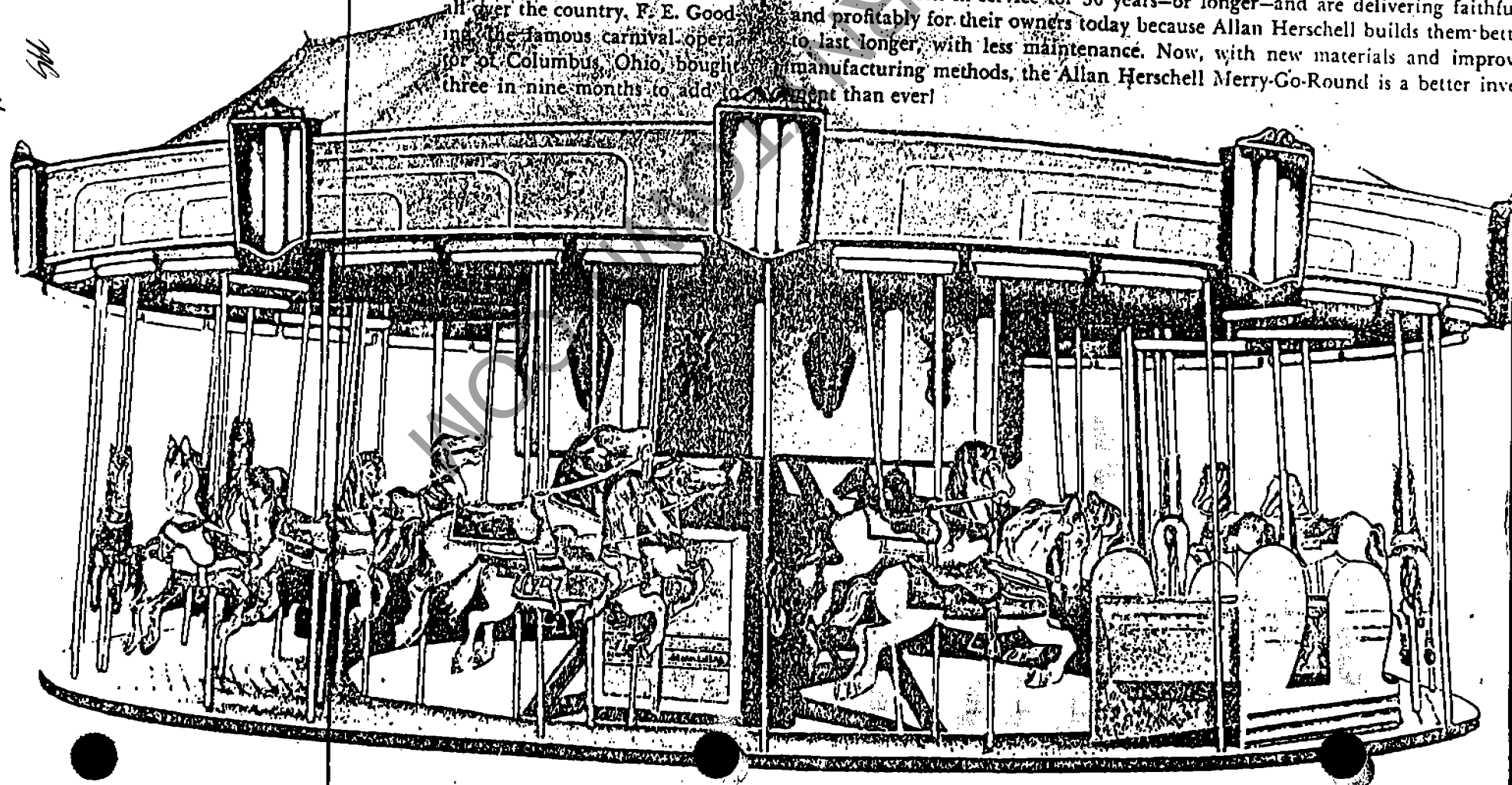

ALLEN HERSCHELL
CHANGE
SM



Number: B30-0259-00

Date: 7-26-84

Supersedes:

America's Largest Manufacturer of Amusement Rides

SERVICE BULLETIN

Effective Serial Numbers: All Units

Ride: MERRY-GO-ROUND

Subject: Horse Hanger Hook Inspection

CHANCE MANUFACTURING COMPANY, INC. requires that all owners of Allan Herschell and Cha MERRY-GO-ROUNDS inspect the horse hanger hooks and horse hanger bearings as described in this bulletin. This inspection is necessary to ensure that the horse hanger hooks are attached securely to the horse hanger bearings.

Perform the following inspection on ALL horse hanger hooks and bearings.

1. Measure the distance between the hooks as shown below. The dimension must be 3-3/8 inches.

MG-70 Horse Hanger Hook
D.P. No. 330-34240

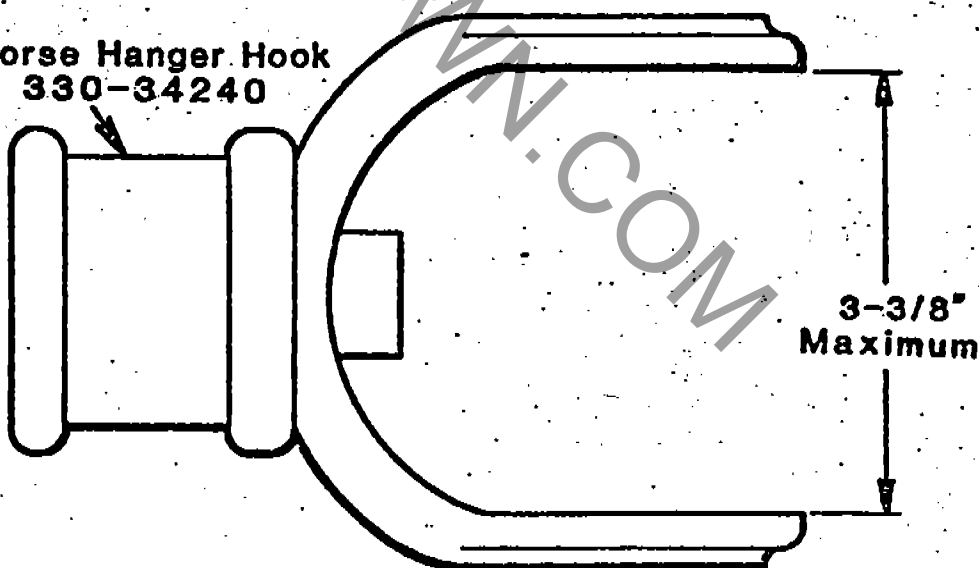

WARNING: DO NOT HEAT THE HORSE HANGER HOOK TO STRAIGHTEN IT.

2. Install the horse hanger hook on the horse hanger bearing. Measure the clearance between the two parts as shown on the following page. The clearance must be no more than 5/32 inch.

NOTE: The horse pole must be vertical when measuring clearance.

MG-4 Horse Hanger
Bearing Assembly
D.P. No. 330-04564

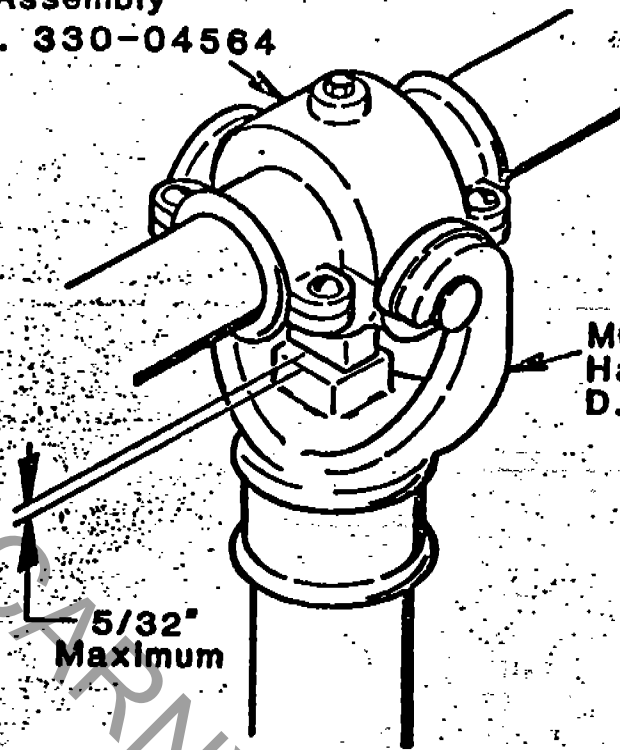

MG-70 Horse
Hanger Hook
D.P. No. 330-34240

5/32"
Maximum

If there is any variation from the dimensions specified; contact CHANCE MANUFACTURING immediately for corrective action.

PUGH SHOWS, INC.
WHITE UNIT

NOTE:

TOP OF TELESCOPE PIPE MUST BE CHAMFERED AS SHOWN TO PREVENT A SHARP EDGE FROM CUTTING INTO HORSEPIPE RESULTING IN A JAM BETWEEN THE TWO PIPES.

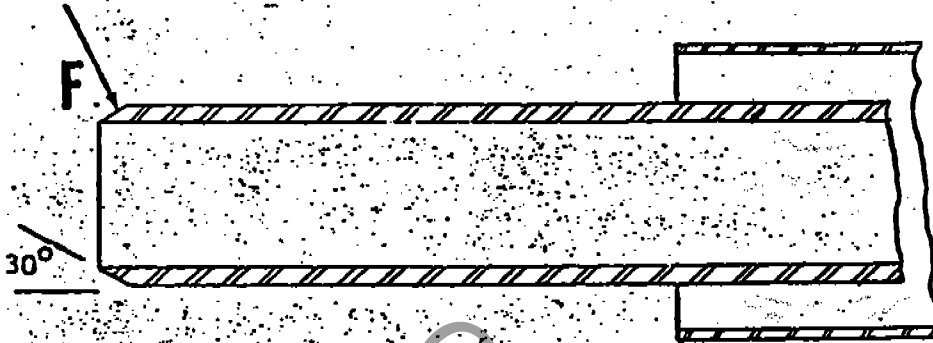

NOTE:

BOTTOM CASTING EARS AND MATING EARS ON TELESCOPE LOCK SHOULD BE CHECKED FOR EXCESSIVE WEAR WHICH COULD CAUSE THE TELESCOPE TO DISENGAGE FROM THE LOCK.

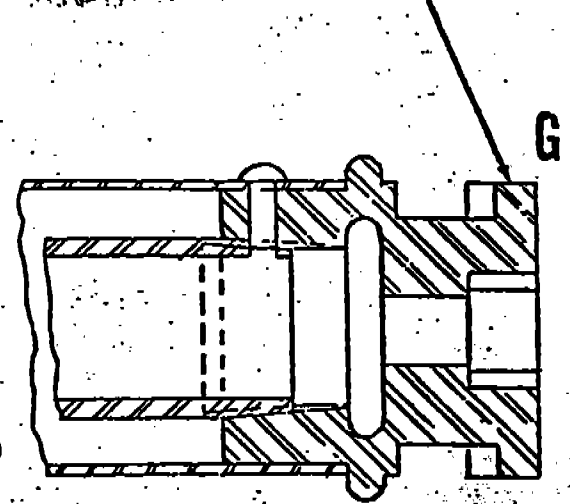

NOTE:

ALL HORSE HANGER HOOKS AND BEARINGS SHOULD BE INSPECTED FOR EXCESSIVE WEAR AT POINT "A". EXCESSIVE WEAR WILL RESULT IN INCREASED CLEARANCE BETWEEN STOPS "B" AND "C" WHICH SHOULD NOT EXCEED 3/16".

1/8" x 45° CHAMFER ON BOTTOM OF HORSE PIPE TO PREVENT A SHARP EDGE FROM CUTTING INTO TELESCOPE RESULTING IN A JAM BETWEEN THE TWO PIPES.

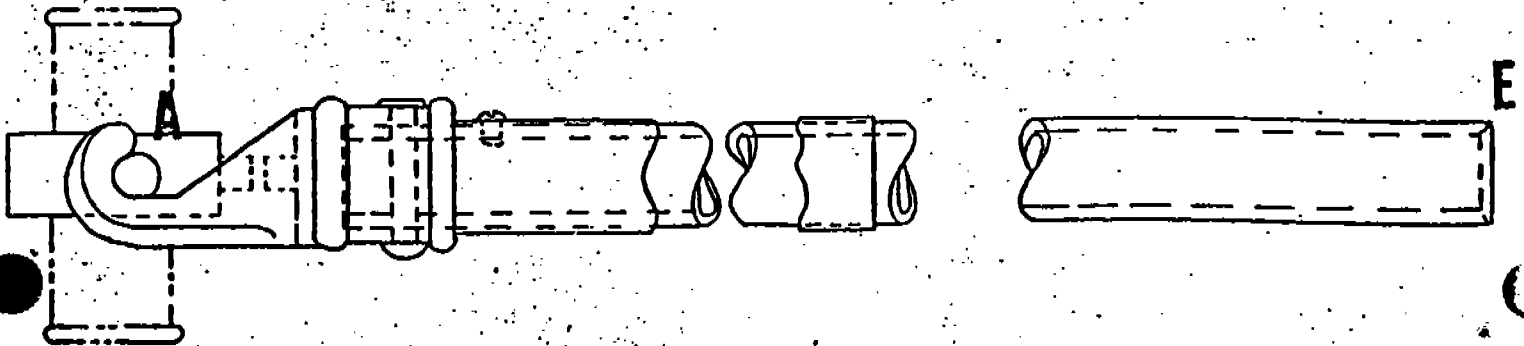
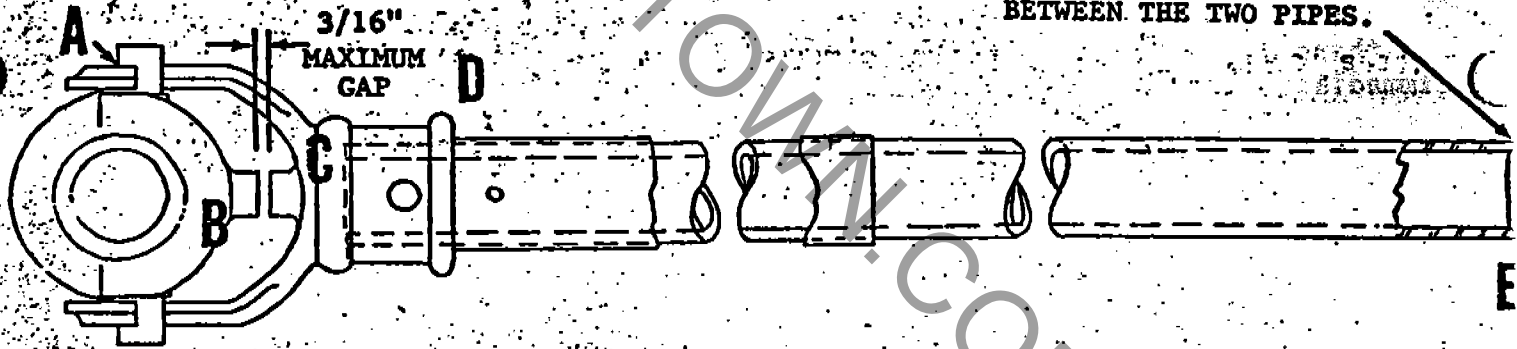



Number: B30-0259-00

Date: 7-26-84

Supersedes:

America's Largest Manufacturer of Amusement Rides

SERVICE BULLETIN

Effective Serial Numbers: All Units

Ride: MERRY-GO-ROUND

Subject: Horse Hanger Hook Inspection

CHANCE MANUFACTURING COMPANY, INC. requires that all owners of Allan Herschell and Ch MERRY-GO-ROUNDS inspect the horse hanger hooks and horse hanger bearings as described in this bulletin. This inspection is necessary to ensure that the horse hanger hooks are attached securely to the horse hanger bearings.

Perform the following inspection on ALL horse hanger hooks and bearings.

1. Measure the distance between the hooks as shown below. The dimension must be 3-3/8 inches.

MG-70 Horse Hanger Hook
D.P. No. 330-34240

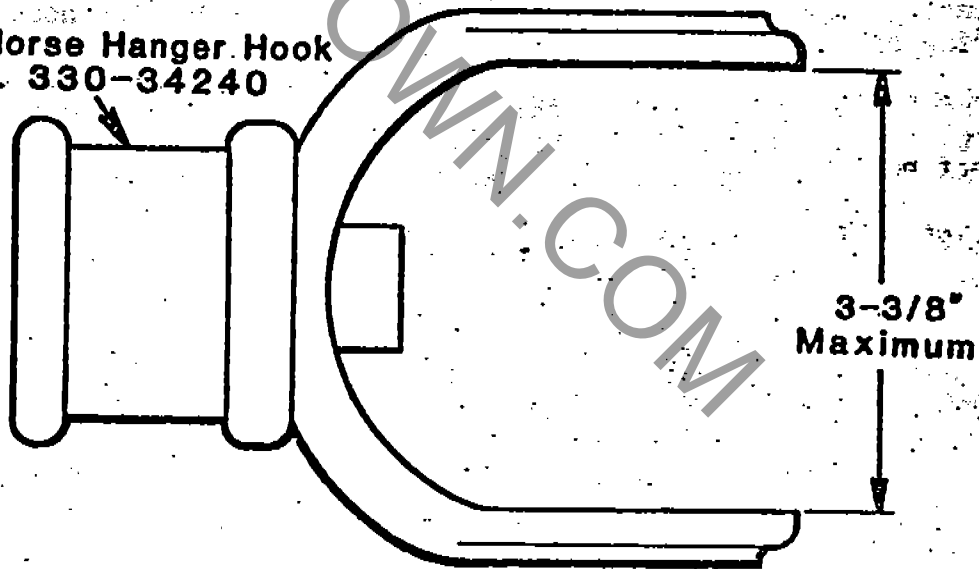

WARNING: DO NOT HEAT THE HORSE HANGER HOOK TO STRAIGHTEN IT.

2. Install the horse hanger hook on the horse hanger bearing. Measure the clearance between the two parts as shown on the following page. The clearance must be no more than 5/32 inch.

NOTE: The horse pole must be vertical when measuring clearance.



Number: B -0241-00

Date: 10-20-82

Supersedes:

America's Largest Manufacturer of Amusement Rides

SERVICE BULLETIN

Effective Serial Numbers: ALL RIDES MANUFACTURED BY CHANCE MFG.

Ride: MERRY-GO-ROUND (36' & 45') Subject: HORSE PIPE AND TELESCOPE ASSEMBLIES

We have received information of isolated instances where the horse pipe has come off the horse hanger bearing while the ride was in operation.

This may have been due to excessive wear on top of the horse hanger bearing ears and the underside of the horse hanger hook (Point A on attached illustration). Wear at this point increases the gap between safety stops (Points B and C) which should not exceed 3/16". Any gap larger than 3/16" will allow the hook to come off the bearing during operation.

Using a piece of bar 3/16" thick, check the gap between each of the safety stops, if the bar passes easily through the gap, the hanger bearings should be replaced. Inspect horse hanger hook and replace if excessive wear is evident.

The tightness of the horse hanger hook on the horse pipe (Point D) should also be checked. If this is loose it will allow it to wobble which will wear out the rivets attaching it to the hook.

All horse pipes furnished by Chance Manufacturing Co., Inc. have a 1/8 x 45° chamfer on the bottom (Point E) and telescope pipes have a 3/16" x 30° chamfer on the top (Point F). These are to prevent the two pipes cutting into one another and jamming. Any replacement pipes should also be chamfered.

The lower casting on the telescope (Point G) and the upper casting on the floor lock should be inspected for wear or damage. Excessive wear could result in release of the telescope from the floor lock. Parts which allow easy locking or unlocking are worn and should be replaced.

$$W = \frac{VK}{R}$$

Where W = rotational rate (RPM)
Where R = radial distance (feet)
Where V = peripheral speed (feet/minute)
Where K = conversion constant = ?

What is the value of this constant (K)?

To calculate the value of K we know that the circumference (C) of a circle is:

$$C = (\pi)D \text{ or } C = 2(\pi)R$$

Where D is the diameter and R is the radius

(π) has a value of 3.14159

The peripheral speed (V) would be

$V = C \times W$ with the units of:

$$\frac{\text{ft}}{\text{Min}} = \text{ft/Rev.} \times \frac{\text{Rev.}}{\text{Min.}}$$

$$\text{Therefore } W = \frac{V}{C} \text{ or } W = \frac{V}{2(\pi)R}$$

K then becomes $\frac{1}{2(\pi)}$ or .159155

The equation could be rewritten as:

$$W = \frac{V \times .159155}{R} \text{ if the peripheral speed (V) is allowed to vary}$$

If V is fixed at 1100 ft/min then the equation becomes:

$$W = \frac{175.07}{R}$$

The calculated values of W are correct

Technical Note - Allow Merry-Go-Round Speeds

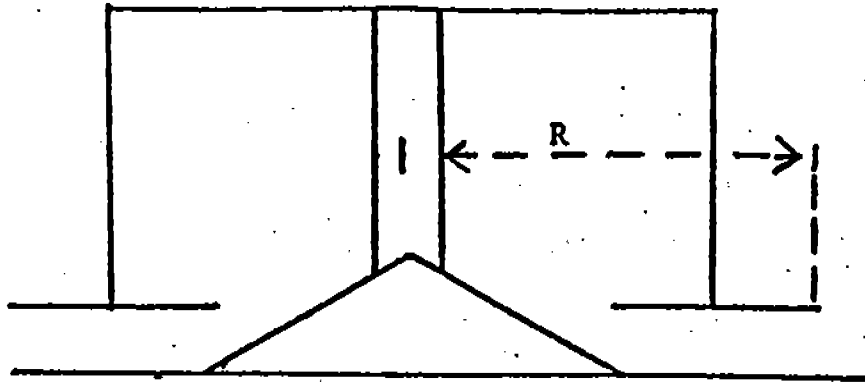

1. Peripheral Speed to be 1,100 feet/minute

Peripheral Speed = Speed at maximum radial distance (R),
on platform, from center of ride

2. $W = \frac{VK}{R}$ Where W = rotational rate (RPM)

Where R = radial distance (feet)

Where V = peripheral speed (feet/minute)

Where K = conversion constant - See Page Four

<u>R (feet)</u>	<u>W (RPM)</u>
10	17.5
12	14.6
14	12.5
16	10.9
18	9.7
20	8.7
30	5.8

INFORMATION

- Clean major gear yearly (large bevel)
- Change hydro-sheave oil yearly
- Link belt reducer; 600 weight oil
- Keep telescopes well greased
- Reverse drive chain annually
- Gasoline engines
 - .. no fuel storage
 - .. fire extinguishers less than or equal to 50 feet away (Class A)

136

MERRY-GO-ROUND (CAROUSEL-cont'd.)

- . Listen for loud squeaks in upper part of center pole
- . Check horses and benches
- . Inspect horses and stirrups for broken, loose, or missing parts
- . Mounting stirrup to be on center platform side of horse or animal
- . Inspect horse hanger hooks and bearings
- . San Antonio - pins on upper crank retainers must be in, such that the crank rotation keeps them in; check all pins, safety fasteners, set screws, and nuts to insure that they are secure and tight
- . Herschell - examine platform telescope locks for broken springs and that they are locked down
- . Inspect horse pole telescopes and sockets
- . Outside horse telescopes are longer than inside telescopes
- . Leading edges of telescopes should be rounded, free of sharp edges or splits
- . Inspect Platforms - damage loose metal, rotten wood, broken boards
- . Examine brake lining
- . Inspect magnetic brake operation (Non-hydraulic driven rides only)
- . Inspect for hydraulic leaks (Hydraulic driven rides only)
- . Inspect ride for excessive vibration
- . Inspect RPM of ride - per data on I.D. plate
- . No rings
- . No reins

MERRY-GO-ROUND (CAROUSEL)

PRIORITY ITEMS

- . Inspect blocking and leveling
- . Ride to be assembled on level ground
- . Floor to be at least 4 inches off ground or floor
- . Keep all surrounding equipment, benches, or fence, at least 6 feet away
- . Electrical - see Ride Electrical Inspection
- . Inspect for proper grounding
- . Inspect all electrical connections to commutator
- . Inspect all brushes for tension and wear
- . Inspect electrical circuit for shorts, bad wires, etc.
- . Inspect structure for cracks, bad welds, etc.
- . Inspect hub and banjo braces, brace pins, and clevises
- . Check guy rod, rod pins, and rod end clevises
- . Check spider gear and shaft collar for tightness
- . Make certain gears, belts, and pulleys are guarded
- . Inspect drive chain and sprockets for alignment and tension
- . Inspect drive belts for proper tension or deflection
(Deflection = belt span in inches \div 64)
- . Inspect crankshaft bearings for wear
- . Crankshaft throws should be 180° off set on alternate shafts
- . Inspect sweep attach points for signs of wear
- . Make certain that the 1/8 inch thick phenolic collar is present under the top bearing

36. Inspect the outside scenery. It shall be secured to the sweeps.
37. Inspect the lights on the outside scenery. All light sockets shall have lights installed in them. This is to insure that patrons do not stick their fingers in the sockets.
38. Inspect the hanger rods from the center pole. Rods should be in pairs. They are part of the main structural system of the ride. All of the weight of the ride and its passengers is supported from these rods.
39. Inspect chariot for stability. Inspect all pins and connections.
40. Information:
- A. Clean major gear yearly (large bevel).
 - B. Change hydro-sheave oil yearly.
 - C. Link belt reducer; 600 weight oil.
 - D. Keep telescopes well greased.
 - E. Reverse drive chain annually.
 - F. King: Stationary animals to be secured to platform.

PUGH SHOWS, INC.
WHITE UNIT

20. Inspect sweep attach points for signs of wear.
21. Inspect crankshaft bearings for wear.
22. Inspect horse hanger hooks and bearings.
23. Inspect horses, stirrups, and reins for broken, loose or missing parts.
24. Inspect horse pole telescopes and sockets.
25. Inspect magnetic brake operation (Non-hydraulic driven rides only).
26. Inspect for hydraulic leaks (Hydraulic driven rides only).
27. Inspect ride for excessive vibration.
28. Inspect structure for cracks, bad welds, etc.
29. Inspect electrical circuit for shorts, bad wires, etc.
30. Inspect all pins are not worn and are keyed.
31. Inspect sway rods. A total of four are required for all merry go rounds. Rods should be reasonably straight. Rods should be secure at top and bottom connections and be snug but not tight. Rods will move during operation and this is acceptable.
32. Inspect sweep spacer members. These are made of timber and support the cranks from which the horses hang. Look for broken members and broken or loose connections.
33. Two types of platforms are on merry go rounds. Some have aluminum floors and some have timber floors. On timber floors, look for broken or splintered members. These should be replaced.
34. Inspect the edge of the platform. Edge shall not have any sharp edges or protruding pieces of trim. These shall be repaired.
35. Inspect the inside scenery. It shall be secure.

MERRY-GO-ROUND

1. Check guy rod, rod pins, and rod end clevises.
2. Check spider gear and shaft collar for tightness.
3. Make certain that the 1/8 inch thick phenolic collar is present under the top bearing.
4. Inspect hub and banjo braces, brace pins, and clevises.
5. Leading edges of telescopes should be rounded, free of sharp edges or splits.
6. Herschell: Examine platform telescope locks for broken springs and that they are locked down.
7. Make certain gears, belts, and pulleys are guarded.
8. Speed: see Table (peripheral speed less than or equal to 1100 feet per minute).
9. Ride to be assembled on level ground and properly blocked.
10. Listen for loud squeaks in upper part of center pole.
11. Examine brake lining.
12. Floor to be at least four inches off ground or floor.
13. Gasoline Engines: No fuel storage.
14. Outside horse telescopes are longer than inside telescopes.
15. Mounting stirrup to be on center platform side of horse or animal.
16. Inspect drive chain and sprockets for alignment and tension.
17. Inspect drive belts for proper tension or deflection (Deflection = belt span in inches divided by 64).
18. Inspect all brushes for tension and wear.
19. Inspect all electrical connections to commutator.

MERRY-GO-ROUND

Page 7

MAINTENANCE SUGGESTIONS (continued)CAUTION:

Belt adjustment must be made by moving the engine or the motor--never by moving the fixed position of the gear reducer.

- (b) The life of the entire drive unit and chain will be increased if the chain is removed once a year and reinstalled in an upside down position. A removable chain link is installed for this purpose.
- (c) Remove slack from the drive chain when it becomes more than 1/8" to 1/4" by using the set screw and locknut on the banjo. It is important that the chain is not too tight or excessive wear results.
- (d) The automatic electric brake brings the ride to a gentle but positive stop with either the gasoline or electric motor. On electric drives, the brake is automatically applied when the electric timer switch stops the flow of current to the motor and brake.

On gasoline engine drives, the brake is controlled from a manual toggle switch near the timer. A new brake usually requires several adjustments until the brake shoe surfaces are properly seated. Adjustments for torque, lining wear and equalizing brake shoe clearance are to be made according to the instructions on the nameplate of the brake assembly. A set screw and lock nut mounted on top of the solenoid frame provides adjustment for equalizing clearance between the two brake shoes to prevent dragging when the brake is released.

PUGH SHOWS, INC.
WHITE UNIT

LUBRICATION (continued)

3. Use Grease gun (furnished in tool kit) on the upper bearing. Use Mobil MP Grease or King Graphite Product KGP-24.
4. Keep breather fitting clean and open.

It should be noted that when the Merry-Go-Round is first started in cold weather after it has been idle for some time, the oil in the drive shaft worm reducer is sometimes congealed and tends to create an overload on the motor. When this occurs it is advisable to assist the first few initial rotations by hand pushing and then operating the machine for fifteen minutes until the lubrication is warmed.

- (c) Use the grease gun furnished in the tool box for the following marked fittings.

Use Mobil MP Grease or King Graphite Product KGP-24.

1. Motor (ball bearing type only)
2. Horse pipe top bearings - 30 places
3. Crankshaft tee bearings - 10 places
4. Top of vertical drive shaft - 1 place
5. Top of center pole cap spider - 1 place
6. Bearing on vertical drive - 2 places
7. Telescope horse pipes - 30 places
8. Sweep arm hub - 2 places
(top and bottom)

- (d) Drive chain is lubricated with Socony PD-1020A or Shell Retinax "A".

- (e) SAE-30 motor oil is used to lubricate the bronze bushing at the top of the center pole and can be reached with an oil can from a hole drilled near the bottom of the tent pole.

MAINTENANCE SUGGESTIONS

- (a) Check "V" belts on drive unit for proper tension. When new, adjustment should be made frequently until the initial stretch is taken up. Do not make belts too tight and they will need very little attention during the season.

MERRY-GO-ROUNDS

Page 5

ERECTION OF CENTER POLE ASSEMBLY (Dwg. 268) (continued)

14. Double check all pins, safety pins, set screws and nuts to make certain that they are secure and tight.
15. The canvas sidewalls are secured to the eyelets on the sweep arms and then rolled to the top and secured to the sweep arms with the webbing straps provided.
16. Carefully double check all fittings, pins, safety pins, nuts, cotter keys and electrical connections for security. Lubricate the entire Merry-Go-Round per instructions before starting the motor.
17. Clear the Merry-Go-Round of all tools, light cords, crates, etc. before testing the unit.

LUBRICATION

If a regular program of lubrication is followed, using recommended oil and grease, you will be rewarded with many, many years of trouble-free operation and few maintenance problems. Before the first operation of the Merry-Go-Round, lubricate the entire machine, with the exception of the gear reducer, using Socony PD-1020-A or the Shell Retinax "A" which is shipped in the tool box. When the Merry-Go-Round is located near salt water, use Fiske Bros. Lubriplate #630-AA. If a gasoline engine is used for power, a good grade of SAE #20 automobile oil is used in the crankcase.

- (a) Fluid Drive Unit - At the factory, the fluid drive clutch has been given the correct amount of premium grade SAE #10 for proper operation. Change the oil at start of each season and check monthly. A slippage of 85 RPM of motor and RPM of fluid clutch drive is standard. Excess slippage indicates the need for additional oil. When filling or adding oil to the clutch, the mark on the housing rim at the 2-1/2" position is placed top dead center. This will position the filler plug opening 36 degrees off center so that oil added until it starts to run out of the opening will properly fill the clutch. Use SAE #10-W oil. Gasket compound is recommended for plug threads to eliminate leakage. The fluid clutch bearings are lubricated for life and require no attention.
- (b) Vertical Drive Shaft Worm Reducer Link Belt V-350 on 36' Merry-Go-Round. Link Belt WV-500 on 45' Merry-Go-Round.
 1. Follow instructions on the name plate using 600-W in warm weather and a combination of 1/2 SAE #40 and 1/2 of 600-W in cold weather. Maintain the proper level.
 2. Drain and refill after 150 hours of operation.

MERRY-GO-ROUNDS

Page 4

ERECTION OF CENTER POLE ASSEMBLY (Dwg. 268) (continued)

Numbered wooden platforms are now positioned over the support channels in their proper location under the numbered sweep arms and the top nuts of the platform hanger rods drawn tight to secure. Note that the chariot platforms are to be placed under #1, #2, #7 and #8 sweeps, and that these two wooden platforms contain metal keyways to lock the chariots in place. Hook two turnbuckle sway rods to the eye welded in the #2 sweep arm above the inside edge of the platform and spread right and left to be secured at the lower ends under platform support channel nuts. Repeat this operation with two sway rods hooked to the eye on #8 sweep arm. The sway rod turnbuckles are properly adjusted during the ride testing at the factory and should not be too tight. Some "play" is required in all sway rods.

10. Hang horsepipe (MG-267) from the crankshaft bearings with grease fittings of bearings located on top. Carefully place horses on horsepipes and secure with horse foot stirrups pinned through horse pipes and top metal stirrup ears recessed in holes in the belly of the horse. Pull horse and horse pipe toward outside of Merry-Go-Round and insert the bottom of horse pipe into a well-greased telescope assembly. Return the entire unit to an upright position, and mate telescope to socket in wooden platform by pressing down and giving it a quarter turn to lock. Alternate various colored horses for the most pleasing effect. Note that the small horses and rod telescope assemblies are for the inside row only, with the medium size horses in the center row, and the large horses on the outside row for the most impressive display.
11. Install the chariots on platform between sweeps #1, #2, #7 and #8. Lock in place on platform by inserting base pins of chariots into metal keyway slots in platform and push into restricted ends of keyway.
12. The drive shaft brace (MG-261-1), is commonly called the "banjo" and is secured to the ears of the center pole sweep hub and it projects at right angles. Attach the two banjo brace legs (MG-242) to the banjo and mud sills and secure with set screws, cotter key and pins. Remove the wire holding the drive chain to the large sprocket and pull the slack in chain over the top of the banjo. Insert vertical drive shaft (MG-237) in upright position through the banjo and mate the top bearing assembly slots with the track on the banjo. The drive chain must be placed around the small sprocket at the top of the drive shaft before it is positioned in the banjo track. Lower flange studs of drive shaft are positioned in the gear reducer flange at the same time the upper bearing is mated to the banjo tracks. Obtain proper chain tension with adjusting screw until the chain has a slack of only 1/8" to 1/4" and then tighten the lock nut.
13. Install the center scenery panels so the Indian Heads and scenery alternate. Attach the lights to the center panels. Secure commutator. Thread BX cable harness from commutator through drilled hole to center pole and drop to the bottom hole where one end is drawn out to attach to switch and timer control box. Bolt the switch box assembly (SP-102) in proper position and lock in place on the mud sill. Assemble the brush assembly (MG-254) and contact fingers (MG-255-1) in the proper position and lock in place with set screw. Assemble electrical twist locks on all electrical connections. The short electrical harness is placed between the power unit and the switch is connected to the switch control box.

MERRY-GO-ROUNDS

Page 3

ERECTION OF CENTER POLE ASSEMBLY (Dwg. MG-268) (continued)

4. Nail together the staging ladders and place plank in position at right angles to center pole to make a scaffold for installation of the sweeps, the hanging rods and positioning of crankshafts. The scaffold can remain in one position and the entire moving assembly rotated by hand around to this one location. Hook one long and one short sweep guy rod (MG-26 -1 and 2) into opening #1 of the spider at the top of the center pole. Insert the #1 sweep arm MG-248 into the mating numbered slot of the sweep hub. Attach long and short guy rods to proper fittings at the top of the sweep arm. Repeat this operation in sequence for all sweep arms. NOTE: (On the 45° Merry-Go-Round, the sweep arms which carry the electric wiring must be placed opposite each other).
5. Assemble the inside and outside sweep arm cross rails (MG-226-142) between sweep arms with safety pins. Note that the cross rails without bearings are placed between sweep arms #1 and #2, #7 and #8 since the chariots are used below these locations.
6. Install crankshafts (MG-279-1) in position, alternating large and small bevel gears with small gears to center of bevel gear. The crankshaft throws must be 180 degrees apart on alternate shafts to give proper action to the jumping horses. When a fixed scaffold is used, the Merry-Go-Round is rotated by hand to bring the work into proper position over the scaffold. The crankshaft throws can each be placed in an upright position and they will properly position themselves. Note that no crankshafts are used between sweeps #1, #2, #7 and #8 because of the chariot positions. The crankshaft tee bearings are inserted over the vertical studs on the sweep hub and the set screws tightened to lock in place.
7. The outside numbered scenery panels are called cornices (MG-161), and are positioned at ends of the sweep arms in sequence to mate with sweep arm numbers. Move the wooden scaffold to outside ends of sweep arms as they are removed from the packing crate. The cornices are locked in place with large flat metal keys. The cornice light shields (MG-171) are hung at the cornice joints and secured with thumb screws at the bottom edge of the shields. Notice that each cornice is numbered and must be mated in proper sequence to sweep arms while light shields are interchangeable.
8. The two halves of the canvas tent top are spread over the top of the sweep guy rods with the smooth side of the canvas facing the top. Care must be taken so as not to tear or damage the canvas. The draw lines for block and tackle are allowed to hang alongside the center pole and metal split ring of tent top assembled around draw lines. With the block and tackle attached to the split ring at the top of the canvas, individually pull each half of the tent top into position. Lace the two halves together and snap outside edges to cornice. Add vertical metal quarter poles to underside of canvas to provide additional support and give characteristic shape to tent. The draw lines of tent top block and tackle may be secured to metal eyes on #2 and #8 sweeps.
9. Hook Platform Hanger Rods (MG-195) to eyes welded to underside of sweep arms. Place metal platform support channels in place over the bottom nut on the end of the platform support rods. The platform channels have one end beveled, and this beveled end should be facing the outside of the Merry-Go-Round.

MERRY-GO-ROUNDS

Page 2

INSTALLATION AND ASSEMBLY OF CENTER POLE (continued)

and hub, and insert pin and tighten the two set screws on either side of hub to lock in place. Pack bearing surface with a good grade of cup grease and place large fiber washer over bearing surface of hub assembly. Place drive chain sprocket in position with crankshaft bearing studs facing up.

(c) Slide bevel gear (MG-273) over the top of the center pole with the gear teeth facing the top of the pole. Work the bevel gear into mating slots of center pole brace hub and tighten set screws to lock in place. Place drive chain tight around the sprocket and hold in position with short length of wire at the base of excess loop of chain.

(d) Commutator assembly (MG-251-1) is placed on the pole so the junction box faces the top of the pole and the bottom edge of the commutator rests on the bevel gear. Junction box should be aligned with large hold in center pole and final positioning and securing will be made later.

(e) Insert Center Pole Top Hub (J-25-1) in place inside of top of center pole by mating stamped arrows on hub with those on center pole top. Caution must be used so the roller cage bearing is not dropped or damaged. Secure assembly by inserting eyebolt through center pole and hub and lock with nut on eyebolt shaft. Pack thrust bearing E-54 with Mobil MP Grease or King Graphite Product KGP-24, making certain that the thrust bearing is firmly seated in top hub after insertion. Position the Guy Rod Spider over bearing and hub shaft. Insert the metal tent pole and attach the two block and tackle units to tent pole and attach the two block and tackle units to tent pole eyes near the top. The center pole is now "dressed" and ready to raise to vertical position.

3. ERECTION OF CENTER POLE ASSEMBLY (Dwg. MG-268)

(a) Install temporary derrick pole, brace legs and winch, which must be placed relative to drive unit as illustrated on drawing. Insert two handles on the hand winch 90 degrees apart for proper leverage. Draw enough cable out of winch to secure tackle block to eye bolt at the top of the center pole and end of one hub brace pipe (MG-241) to center pole brace hub ear which is facing up while the center pole is resting on the wooden buck. This brace pipe will be used to safety lock the center pole in place when it is first raised to the vertical position.

(b) Slowly turn the winch handles to raise the center pole. When the pole is about halfway up, have one man guide the brace pipe end into its fitting on the mud sill as pole raises and lock in place with pin and safety pin to secure against accidents. When the center pole stands upright, attach the other three brace pipes, making certain that the pin and the safety pin are installed on each end of each brace. After all the brace pipes are secured, the winch and derrick pole can be removed. Use the carpenters bubble level to make certain that the center pole is absolutely vertical. If it is necessary to add shims under the ends of the mud sills to plumb the center pole, make certain that the shims are also added under the mud sill center under the center pole so no gap exists.



ALLAN HERSCHELL

CHANCE
MANUFACTURING CO., INC.

Number: 14

Date: 3-7-72

Supersedes:

Number:

Date:

Service Information

Ride: 36', 40', & 45' MERRY-GO-ROUND Subject: ERECTION & MAINTENANCE

Reference:

Print MG-268 General Arrangement
Print MG-100-PA Parts Numbers and
Lubrication
Print MG-320 Electric Circuit
Electric Consumption Sheet
Packing List

ERECTION INSTRUCTIONS FOR 36', 40', and 45' MERRY-GO-ROUNDS

1. Refer to General Arrangement Drawing MG-268. Lay the foundation in place, which consists of two steel cross members and are commonly called Mud Sills. (MG-229) These Mud Sills must be placed on solid level ground, concrete piers or concrete slab. It is necessary to position the mud sills so that the Drive Unit and winch positions are convenient for erection since this relationship cannot be changed later. Use the carpenters bubble level to make certain that the mud sills are level in all directions. Use thin wood or metal shims under the ends of the mud sills as necessary to obtain a perfect level. If shims are used under ends of mud sills, it is important that the mud sill center under the center pole also be shimmed to assure a tight ground contact. Position the drive base to top of mud sills and secure with taper pins.
2. INSTALLATION AND ASSEMBLY OF CENTER POLE (Dwg. MG-268)
 - (a) Place wooden folding buck support across end of mud sill so the center pole base hinge casting bracket points to support buck. Using several men, position the center pole MG-136-2 on the support buck as per above drawing. If center pole hinge bracket is not bolted in place (export models only) perform this operation making certain that the rounded edges of hinge face bottom of pole. Mate the center pole hinge bracket with hinge casting on center of mud sills, insert hinge bolt and lock in place with nut. When the Merry-Go-Round is taken down, make certain that center pole hinge bolt is loose before lowering the center pole.
 - (b) Slide Center Pole Brace Hub (MG-225) over the top of the center pole so that the bearing surface is facing the top of the pole. Align brace hub with drilled holes in center pole by mating stamped arrows on center pole

Factory and General Office, 4219 Irving, Box 7144 Wichita, Kansas 67201

Area Code (316) 942-7411

Sales Office:

1103 Ross Ave., Dallas, Texas 75202

Area Code (214) 740-0000

ERECTION OF CENTER POLE ASSEMBLY (Dwg. MG-268) (continued)

4. Nail together the staging ladders and place plank in position at right angles to center pole to make a scaffold for installation of the sweeps, the hanging rods and positioning of crankshafts. The scaffold can remain in one position and the entire moving assembly rotated by hand around to this one location. Hook one long and one short sweep guy rod (MG-26 -1 and 2) into opening #1 of the spider at the top of the center pole. Insert the #1 sweep arm MG-248 into the mating numbered slot of the sweep hub. Attach long and short guy rods to proper fittings at the top of the sweep arm. Repeat this operation in sequence for all sweep arms. NOTE: (On the 45' Merry-Go-Round, the sweep arms which carry the electric wiring must be placed opposite each other).
5. Assemble the inside and outside sweep arm cross rails (MG-226-142) between sweep arms with safety pins. Note that the cross rails without bearings are placed between sweep arms #1 and #2, #7 and #8 since the chariots are used below these locations.
6. Install crankshafts (MG-279-1) in position, alternating large and small bevel gears with small gears to center of bevel gear. The crankshaft throws must be 180 degrees apart on alternate shafts to give proper action to the jumping horses. When a fixed scaffold is used, the Merry-Go-Round is rotated by hand to bring the work into proper position over the scaffold. The crankshaft throws can each be placed in an upright position and they will properly position themselves. Note that no crankshafts are used between sweeps #1, #2, #7 and #8 because of the chariot positions. The crankshaft tee bearings are inserted over the vertical studs on the sweep hub and the set screws tightened to lock in place.
7. The outside numbered scenery panels are called cornices (MG-161), and are positioned at ends of the sweep arms in sequence to mate with sweep arm numbers. Move the wooden scaffold to outside ends of sweep arms as they are removed from the packing crate. The cornices are locked in place with large flat metal keys. The cornice light shields (MG-171) are hung at the cornice joints and secured with thumb screws at the bottom edge of the shields. Notice that each cornice is numbered and must be mated in proper sequence to sweep arms while light shields are interchangeable.
8. The two halves of the canvas tent top are spread over the top of the sweep guy rods with the smooth side of the canvas facing the top. Care must be taken so as not to tear or damage the canvas. The draw lines for block and tackle are allowed to hang alongside the center pole and metal split ring of tent top assembled around draw lines. With the block and tackle attached to the split ring at the top of the canvas, individually pull each half of the tent top into position. Lace the two halves together and snap outside edges to cornice. Add vertical metal quarter poles to underside of canvas to provide additional support and give characteristic shape to tent. The draw lines of tent top block and tackle may be secured to metal eyes on #2 and #8 sweeps.
9. Hook Platform Hanger Rods (MG-195) to eyes welded to underside of sweep arms. Place metal platform support channels in place over the bottom nut on the end of the platform support rods. The platform channels have one end beveled, and this beveled end should be facing the outside of the Merry-Go-Round.

MERRY-GO-ROUNDS

Page 2

INSTALLATION AND ASSEMBLY OF CENTER POLE (continued)

and hub, and insert pin and tighten the two set screws on either side of hub to lock in place. Pack bearing surface with a good grade of cup grease and place large fiber washer over bearing surface of hub assembly. Place drive chain sprocket in position with crankshaft bearing studs facing up.

(c) Slide bevel gear (MG-273) over the top of the center pole with the gear teeth facing the top of the pole. Work the bevel gear into mating slots of center pole brace hub and tighten set screws to lock in place. Place drive chain tight around the sprocket and hold in position with short length of wire at the base of excess loop of chain.

(d) Commutator assembly (MG-251-1) is placed on the pole so the junction box faces the top of the pole and the bottom edge of the commutator rests on the bevel gear. Junction box should be aligned with large hold in center pole and final positioning and securing will be made later.

(e) Insert Center Pole Top Hub (J-25-1) in place inside of top of center pole by mating stamped arrows on hub with those on center pole top. Caution must be used so the roller cage bearing is not dropped or damaged. Secure assembly by inserting eyebolt through center pole and hub and lock with nut on eyebolt shaft. Pack thrust bearing E-54 with Mobil MP Grease or King Graphite Product KGP-24, making certain that the thrust bearing is firmly seated in top hub after insertion. Position the Guy Rod Spider over bearing and hub shaft. Insert the metal tent pole and attach the two block and tackle units to tent pole and attach the two block and tackle units to tent pole eyes near the top. The center pole is now "dressed" and ready to raise to vertical position.

3. ERECTION OF CENTER POLE ASSEMBLY (Dwg. MG-268)

(a) Install temporary derrick pole, brace legs and winch, which must be placed relative to drive unit as illustrated on drawing. Insert two handles on the hand winch 90 degrees apart for proper leverage. Draw enough cable out of winch to secure tackle block to eye bolt at the top of the center pole and end of one hub brace pipe (MG-241) to center pole brace hub ear which is facing up while the center pole is resting on the wooden buck. This brace pipe will be used to safety lock the center pole in place when it is first raised to the vertical position.

(b) Slowly turn the winch handles to raise the center pole. When the pole is about halfway up, have one man guide the brace pipe end into its fitting on the mud sill as pole raises and lock in place with pin and safety pin to secure against accidents. When the center pole stands upright, attach the other three brace pipes, making certain that the pin and the safety pin are installed on each end of each brace. After all the brace pipes are secured, the winch and derrick pole can be removed. Use the carpenters bubble level to make certain that the center pole is absolutely vertical. If it is necessary to add shims under the ends of the mud sills to plumb the center pole, make certain that the shims are also added under the mud sill center under the center pole so no gap exists.



ALLAN HERSHELL

CHANCE
MANUFACTURING CO., INC.

Number: 14
Date: 3-7-72

Supersedes:
Number:
Date:

Service Information

Ride: 36', 40', & 45' MERRY-GO-ROUND Subject: ERECTION & MAINTENANCE

Reference:

Print MG-268 General Arrangement
Print MG-100-PA Parts Numbers and
Lubrication
Print MG-320 Electric Circuit
Electric Consumption Sheet
Packing List

ERECTION INSTRUCTIONS FOR 36', 40', and 45' MERRY-GO-ROUNDS

1. Refer to General Arrangement Drawing MG-268. Lay the foundation in place, which consists of two steel cross members and are commonly called Mud Sills. (MG-229) These Mud Sills must be placed on solid level ground, concrete piers or concrete slab. It is necessary to position the mud sills so that the Drive Unit and winch positions are convenient for erection since this relationship cannot be changed later. Use the carpenters bubble level to make certain that the mud sills are level in all directions. Use thin wood or metal shims under the ends of the mud sills as necessary to obtain a perfect level. If shims are used under ends of mud sills, it is important that the mud sill center under the center pole also be shimmed to assure a tight ground contact. Position the drive base to top of mud sills and secure with taper pins.
2. INSTALLATION AND ASSEMBLY OF CENTER POLE (Dwg. MG-268)
 - (a) Place wooden folding buck support across end of mud sill so the center pole base hinge casting bracket points to support buck. Using several men, position the center pole MG-136-2 on the support buck as per above drawing. If center pole hinge bracket is not bolted in place (export models only) perform this operation making certain that the rounded edges of hinge face bottom of pole. Mate the center pole hinge bracket with hinge casting on center of mud sills, insert hinge bolt and lock in place with nut. When the Merry-Go-Round is taken down, make certain that center pole hinge bolt is loose before lowering the center pole.
 - (b) Slide Center Pole Brace Hub (MG-225) over the top of the center pole so that the bearing surface is facing the top of the pole. Align brace hub with drilled holes in center pole by mating stamped arrows on center pole

Factory and General Office, 4219 Irving, Box 7144 Wichita, Kansas 67201

Sales Office:

1103 Ross Ave., Dallas, Texas 75202

Area Code (316) 942-7411

Area Code (214) 742-2200

WITH FLUID DRIVE

Merry-Go-Rounds

After 79 years of development, the Allan Herschell Merry-Go-Round with new features and steel construction is the smoothest operating, most durable, and fastest-to-erect Merry-Go-Round ever built. It is a sensational success, having received praise from carnival men and park operators all over the country. F. E. Gooding, the famous carnival operator for Columbus, Ohio, bought three in nine months to add to

the 100 rides his company already owned.

In the new Merry-Go-Round, mud sills and sweeps are of steel, thus increasing the already long life of AH Merry-Go-Rounds. The drive is now chain-and-sprocket and, because it is self-aligning, requires less skilled help for setting up and dismantling. Center pole is quickly and safely raised by only two men with the new hand winch and steel pole. (see opposite page). Electric brake automatically stops ride in one revolution.

More Allan Herschell Merry-Go-Rounds are in use today than any other make. Many have been in service for 50 years—or longer—and are delivering faithfully and profitably for their owners today because Allan Herschell builds them better, to last longer, with less maintenance. Now, with new materials and improved manufacturing methods, the Allan Herschell Merry-Go-Round is a better investment than ever!

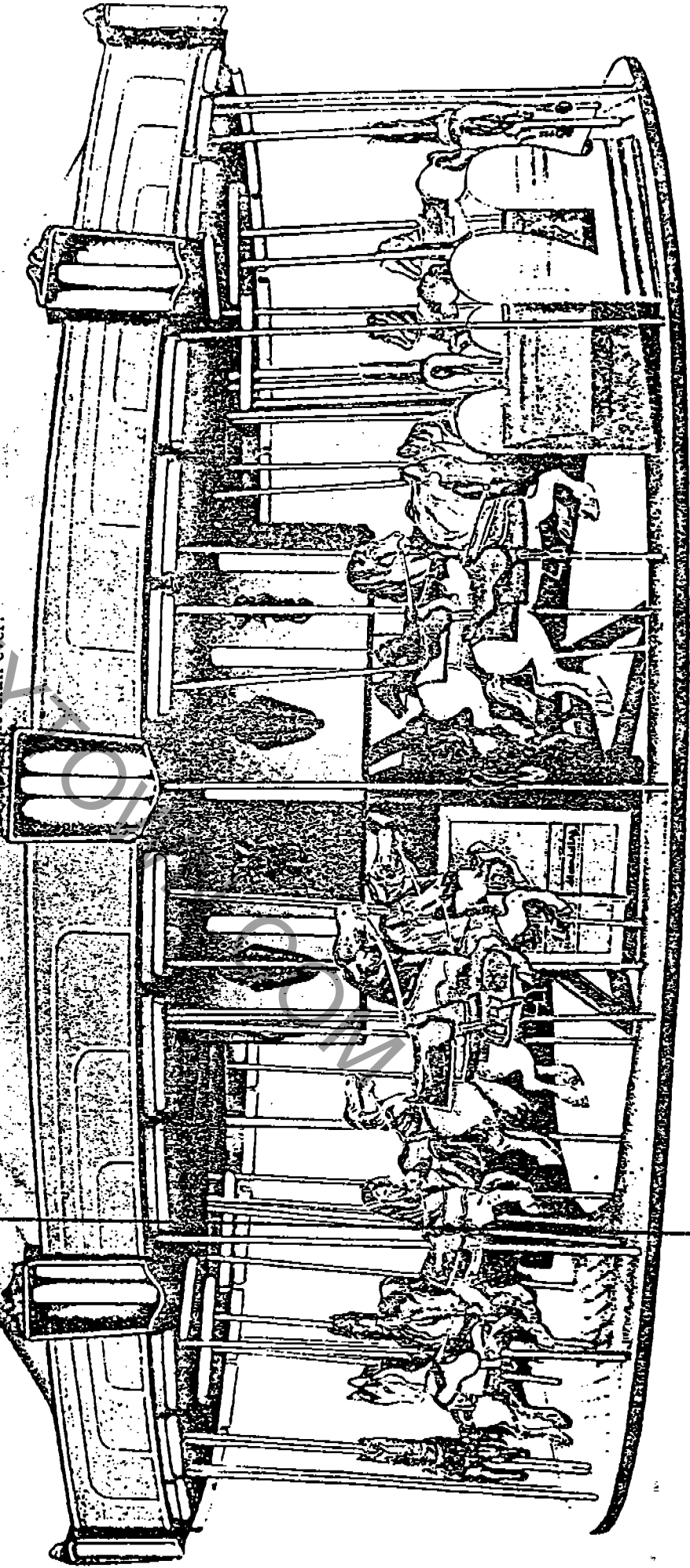

Wm. Herschell
MERRY-GO-ROUNDS
with Fluid Drive

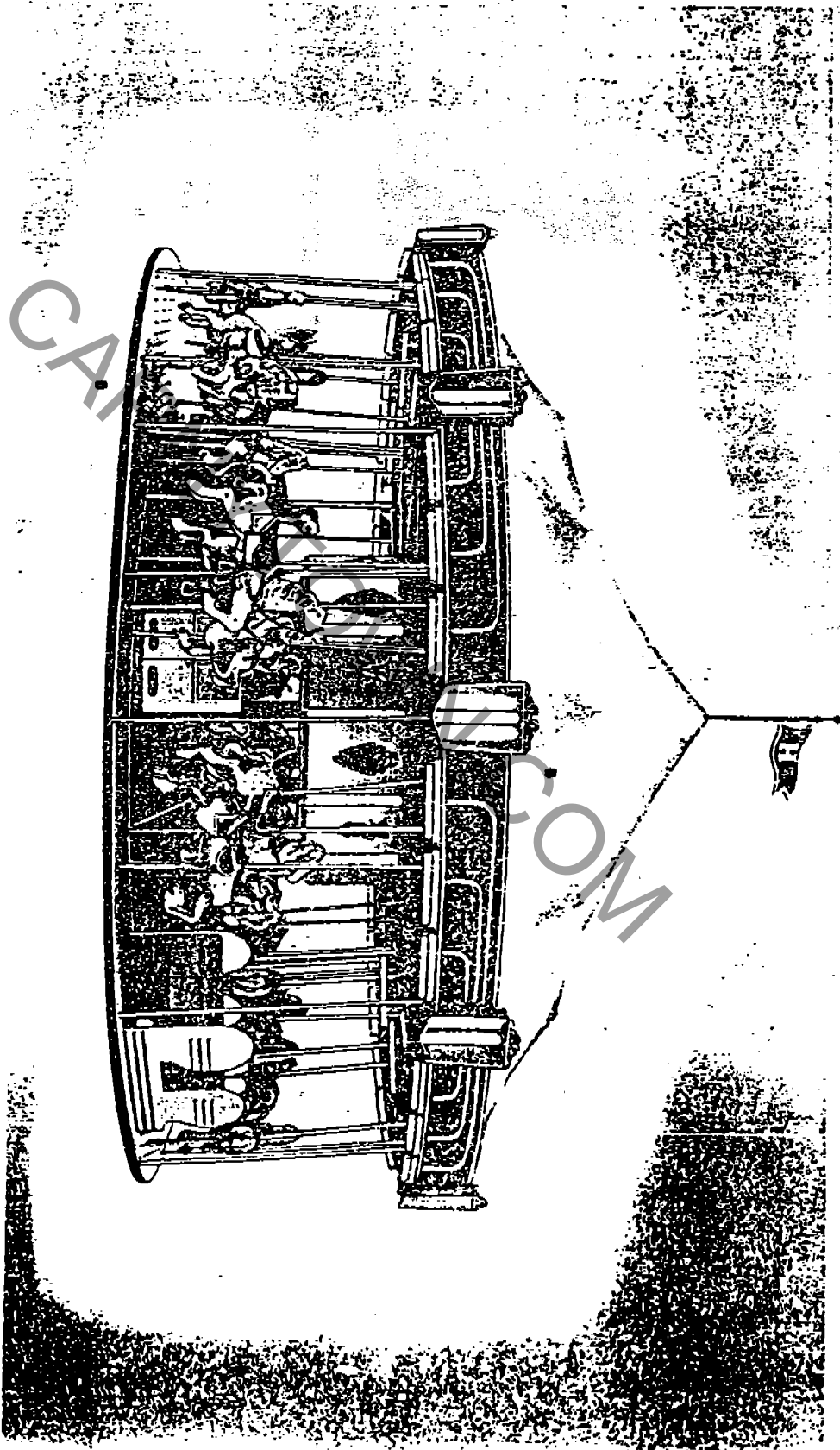

MANY indeed, are the men and women of today with fond childhood memories of thrilling rides on the Merry-Go-Round, with its prancing horses, gaily decorated cornices and tuneful band music. And the Merry-Go-Round still spells fun for the millions of children and grown-ups the world over!

The Allan Herschell Merry-Go-Round has been the choice of farsighted carnival men and park operators since 1880. No other amusement device can approach its record of performance either in length of service or in gross revenue.

More Allan Herschell Merry-Go-Rounds are in use today than any other make. Many have been in service for 40 years — or longer — and are delivering faithfully and profitably for their owners today because Allan Herschell builds them better, to last longer, with less maintenance. Now, with new materials and improved manufacturing methods, the Allan Herschell Merry-Go-Round is a better investment than ever!

Built in five different sizes and styles. Every carrousel completely assembled and tested at the factory before shipping.

SEE OTHER SIDE FOR SPECIFICATIONS

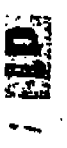



Alan Herschell

MERRY-GO-ROUNDS



Alan Herschell Merry-Go-Round horses are beautifully decorated, and built to take plenty of punishment. They are cast aluminum in 8 sections carefully welded together. Available in a wide variety of poses and decorative treatments.

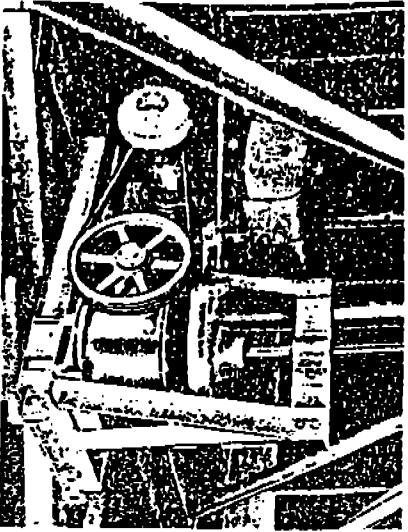

Fluid Drive mechanism is mounted on shaft of standard motor as a single unit. All drive components are firmly attached to frame for accurate alignment. Electrically-driven models have no clutch to adjust or replace and are started and their power is shut off by a timer and magnetic motor starter which are mounted in an all-weather, cast-aluminum control box.

CARNIVAL



Alan Herschell

MERRY-GO-ROUNDS

SIZE AND WEIGHT

Diameter at Platform	36 ft.	36 ft.	40 ft.	45 ft.
Diameter at Cornice	32'-0"	32'-0"	36'-0"	41'-0"
Cornice Height	19'-3"	19'-3"	11'-7 1/2"	15'-0"
Overall Height (Including Taut Pole)	15'-6"	15'-6"	17'-3"	18'-8"
Overall Height (Including Taut Pole)	24'-6"	24'-6"	28'-5"	27'-8"
Weight (Cooled)	18,000 lbs.	20,800 lbs.	22,800 lbs.	30,000 lbs.
Horses (All Jumping)	20	30	36	60
Chariots	2	2	2	2
Total Passengers	20	38	44	68

For specifications, size and weight of Kiddle Merry-Go-Round, see pages 7 and 8.

CONSTRUCTION

Select, dry lumber is used for platforms. Platform-rods and horse-pole are covered with bright anodized aluminum tubing. All models equipped with long-wearing bearings and have finest hardware and fittings. Horses are made of cast aluminum; body is in two sections; head, tail and four legs are separate castings all carefully welded together. Strong, durable plywood is used for chariots. Cornice is made of tempered hardboard on a steel frame with polished stainless steel and aluminum molding. All other parts are carefully constructed and precisely fitted to provide long, trouble-free performance. All electrical wiring is rubber covered and with quick disconnectors for maximum portability.

LIGHTING

Center panels are brilliantly illuminated with fluorescent tubes. Each sweep has a long fluorescent fixture and three are mounted at the bottom edge of each cornice section. Fluorescent fixture are also mounted in stainless steel head shields.

DECORATION

Cornice is a blaze of color, accented with gleaming half-oval stainless steel trim. Sweeps and crosswalks are painted a brilliant red. Horses are artistically and smartly decorated, have English mottled leather reins and stirrup straps. Entire ride is a pleasing blend of the decorator's "flair" and the skill of the true artist. All paints and varnishes used are of the highest quality . . . made to resist the weather and withstand plenty of hard use.

PORTABILITY

The 36 ft. 2-abrest model loads on a single 30 ft. van or semi and can be set up by a 4-man crew in approximately 3 1/2 hours. The 36 ft. 3-abrest model loads on a 32 ft. van or semi. Two 24 ft. vans or semi will accommodate the 40 ft. 3-abrest model.

EQUIPMENT

Tent top, sidewalls, starting bell, crates and all tools necessary to set up and operate are standard with each ride. Merry-Org and Ticket Office are available as extra equipment.

PUGH SHOWS, INC.
WHITE UNIT

12-16-1956 12:07PM FROM TRIADYNE REC ENG 1 702 263 0885

NEW EASY METHOD FOR ERECTING CENTER POLE

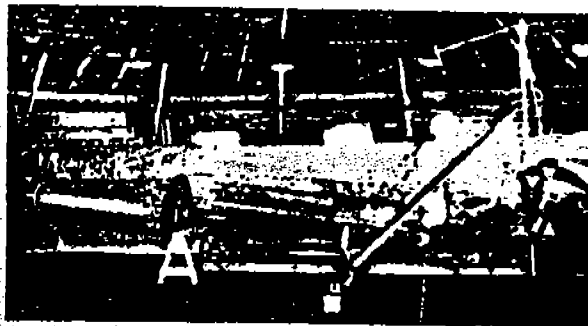

1. Steel winch pole is in vertical position. Block is attached to top of center pole. One brace leg for center pole has been attached to hub by means of a pin and lies along center pole. One man is ready to operate the hand winch; the other, the safety brake.

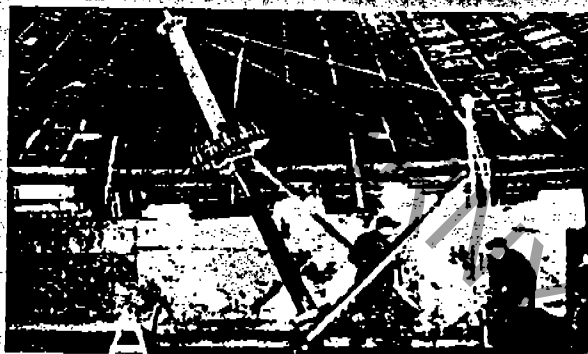

2. Up she goes! With less tension on winch, one man can now operate it and brake at same time. Other man guides brace leg to pin slot on mud sill.

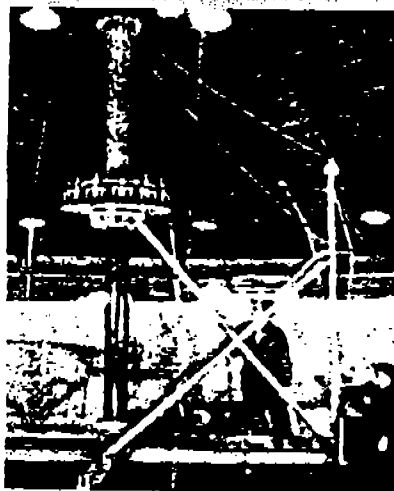

3. Center pole is erect. Lower end of brace leg is about to be planned to mud sill. Note that winch pole is braced by two of the four brace legs of center pole. Later these brace legs will be detached from winch pole and placed in their own positions as braces for center pole.

Specifications

SIZE AND WEIGHT

	36 ft.	36 ft.	40 ft.	45 ft.
Diameter of Platform	2'-abreast	3'-abreast	3'-abreast	4'-abreast
Diameter of Cornice	32'-6"	32'-6"	36'-0"	41'-3"
Cornice Height	36'-0"	36'-0"	40'-0"	45'-0"
Overall Height	10'-3"	10'-3"	11'-7 1/2"	13'-1"
Overall Height	15'-6"	15'-6"	17'-3"	18'-10"
(Including Lost Pole)	24'-6"	24'-6"	26'-5"	27'-6"
Weight (Gross)	18,000 lbs.	20,000 lbs.	22,000 lbs.	30,000 lbs.
Motor (All Jumps)	20	30	38	43
Cranks	7	7	7	2
Total Passengers	28	34	44	44

CONSTRUCTION

Mud sills and sweeps are steel. Select, dry lumber is used for platforms. Platform-rods and horse-pipe are covered with bright anodized aluminum tubing. All models equipped with long-wearing bearings and have finest hardware and fittings. Every part is carefully constructed and precisely fitted to provide long, trouble-free performance. Horses are made of cast aluminum; body is in two sections, head, tail and four legs are separate castings all carefully welded together. Strong, durable plywood is used for chariots. Cornice is made of tempered hardboard on a stool frame with polished stainless steel and aluminum molding. Center pole is easily and safely raised by two men with hand winch and steel pole. Electric brake automatically stops ride in one revolution. Chain and sprocket drive are self-aligning. Fluid clutch and timer are standard. All electrical wiring is rubber-covered cord with quick disconnectors.

LIGHTING

Center panels are brilliantly illuminated with fluorescent tubes. Each sweep has a long fluorescent fixture and three are mounted at the bottom edge of each cornice section. Fluorescent fixtures mounted in stainless steel head shields.

DECORATION

Cornice is a blaze of color, accented with gleaming half-oval stainless steel trim. Sweeps and crossrails are painted a brilliant red. Horses are artistically and smartly decorated, have English tanned leather reins. Entire ride is a pleasing blend of the decorator's "flash" and the skill of the true artist. All paints and varnishes withstand rough weather and hard usage.

PORTABILITY

The 36 ft. 2-abreast model loads on a single 30 ft. van or semi and can be set up by a 4-man crew in approximately 3 1/2 hours. The 36 ft. 3-abreast model loads on a 32 ft. van or semi. Two 24 ft. vans or semis will accommodate the 40 ft. 3-abreast model.

EQUIPMENT

Tent top, sidewalls, starting bell, crates and all tools necessary to set up and operate are standard with each ride. Merri-Org and Ticket Office are available as extra equipment.

ALLAN HERSHELL CO., Inc.

NORTH TONAWANDA (BUFFALO), NEW YORK — Phone: LUdlow 4300

ESTABLISHED IN 1880

"World's largest manufacturer of amusement rides"

MERRY-GO-ROUNDS • BOAT RIDE • KIDDIE AUTO RIDE • PORTABLE ROLLER COASTER • JOLLY CATERPILLAR • SKY FIGHTER • HIGHWAY RIDE
BODFO • TANK RIDE • BUGGY RIDE • GASOLINE SPORT CARS • 18-CAR CAT • RECORD PLAYERS

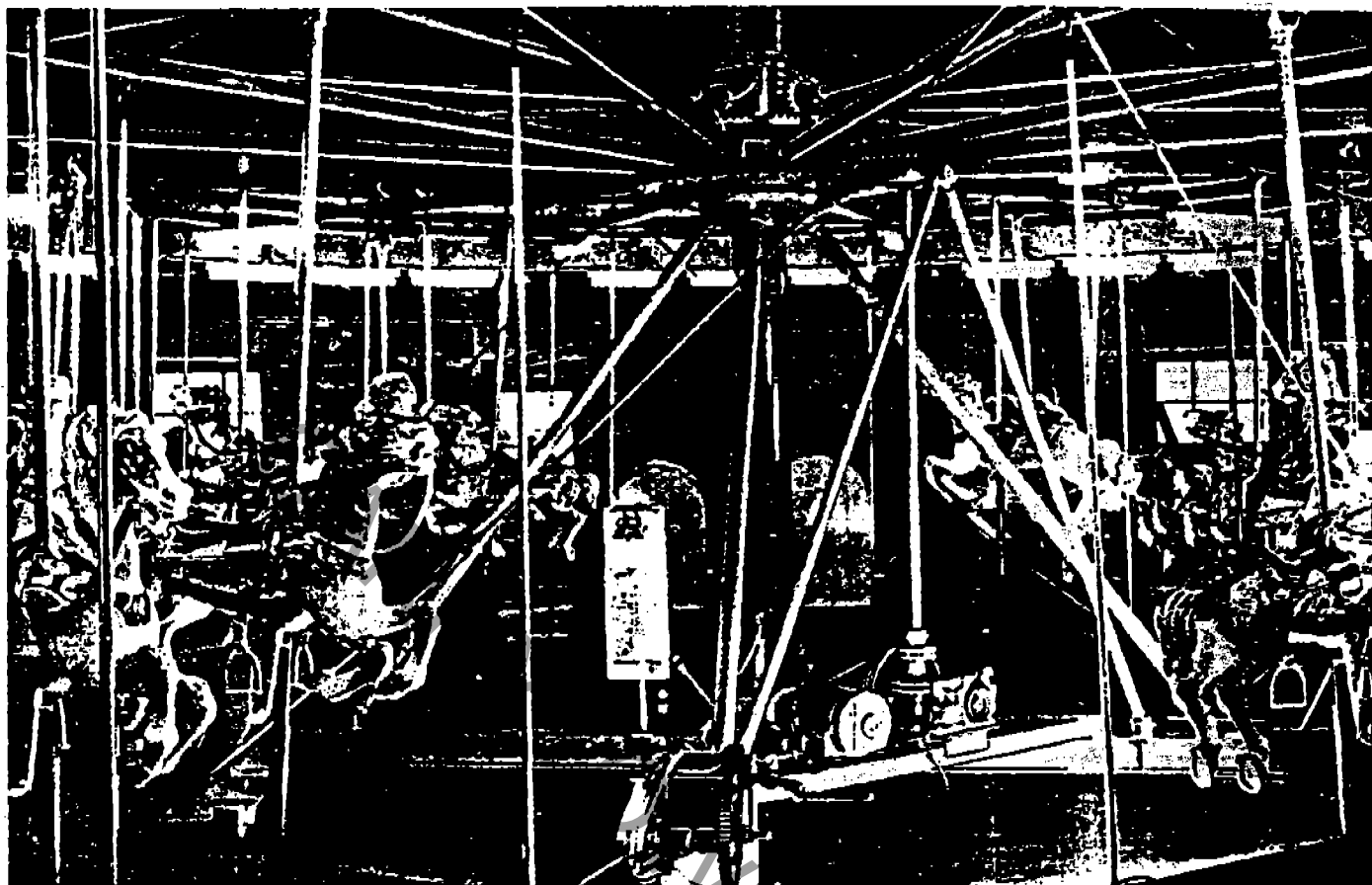

The 1956 Allan Herschell Merry-Go-Round Has New Features and Steel Construction

First choice of carnival men and park operators since 1880, the famous Allan Herschell Merry-Go-Round has been redesigned to include revolutionary new features and methods of construction. These great improvements, which Allan Herschell has been developing at its factory for five years, make the AH Merry-Go-Round the smoothest operating, most durable, and fastest-to-erect Merry-Go-Round ever built.

Mud sills and sweeps are of steel, thus increasing the already long life of AH Merry-Go-Rounds. The drive is now chain-and-sprocket and, because it is self-aligning, requires less skilled help for setting up and dismantling. Center pole is quickly and safely raised by only two men with the new hand winch and steel pole (see reverse side). Electric brake automatically stops ride in one revolution.

Nothing has been done to those fine features

which have made Allan Herschell Merry-Go-Rounds the standard of the world. The aluminum jumping horses are brightly painted by Allan Herschell artisans whose great painting skill has been acquired through many years of experience. Fluid clutch and timer are standard equipment. The tent top and sidewalls are Army Khaki Duck, fitted properly and sewn with nylon thread.

Here is a Merry-Go-Round that will last and last, for 40 and 50 years. That makes it an investment for your grandchildren. The operation of this new Merry-Go-Round is so smooth and quiet you can barely hear it, even though it is a big, big ride with hundreds of parts. You'll be amazed at the ease of handling and transporting. And profits? Why, nothing can ever beat an Allan Herschell Merry-Go-Round for steady, high grosses.