

INTRODUCTION

This "Operation Manual" has been written for the benefit of the ride operator and owner. WMI INDUSTRIES, LTD. advises all ride operators and owners to read this book before operation.

INTENDED USE

The equipment herein described is intended to be used by a commercial operator to provide a service to the buyer's customers. As a commercial operator, the buyer agrees to operate and maintain the equipment for its intended use in a professional and competent manner as per Wisdom recommendations and instructions, industry and governmental standards, and good commercial practices, using professional and competent mechanics and operators. If at any time, and for any reason the equipment cannot be adequately and safely operated for its intended use, the buyer agrees not to operate the equipment until proper repairs or corrections are made.

The SUPER SIZZLER is designed to be a teenage-adult thrill ride. It is not recommended that small children, 11 or younger ride by themselves. They must be accompanied by a responsible adult.

SPECIFICATIONS

CAPACITY.....	36	adults (no more than 3 children per seat.) (600 per hour)
MINIMUM HEIGHT.....	42"	<i>32-33 on seat</i>
ROTATION.....	15	RPM of main center pole.
SET UP AREA.....	50'	circle minimum.
LIGHTS.....	6	QUARTZ LIGHTS
	2230	BULBS
MOTOR POWER.....	30	HP
ELECTRICAL.....	40	KW

## SUPER SIZZLER SETUP INSTRUCTIONS

1. Lower landing gear and disconnect truck.
2. Slide out two rear lifting cylinders and swing up.
3. Pin rear lifting cylinders to the brace arm and side of trailer.
4. Place lifting pads under all lifting cylinders.
5. Provide power to 110 volt hydraulic pump to operate cylinders.
6. Lower rear cylinders until the six inch extension legs can be slipped over the rod.
7. Be sure that the lifting cylinder rods are pushing in the center of the pad. NOTE: put handles on pad sideways so that the axle can roll to the rear of the trailer.
8. Use front cylinders to lift the front of trailer to full extension of the cylinders.
9. Unpin axle assembly, pulling arm, and disconnect brake lines.
10. Lift rear of trailer until the axle can be rolled out.

**WARNING! NEVER CRAWL UNDER TRAILER WHILE IT IS SUPPORTED BY THE CYLINDERS.**

11. Drain air from air brake tank and roll axle out from under trailer.
12. Immediately lower rear of trailer to ground do not leave the trailer raised more than a few minutes without support.

NOTE: block rear of trailer 4 inches off of ground.

13. Level the trailer across the back and the front.
14. Raise rear cylinders, unpin them, and swing them down into the over the road position.

NOTE: There should be about 25 inches difference between the height above the ground from the front to the back of the main part of the trailer.

15. Block the center of the ride and let the front down so that the blocks will be snug.
16. Swing out the main outriggers and brace into position with diagonal braces.

17. Swing out the front platform supports and brace into position.
18. Install rear out riggers and pin.
19. Install all spreader trusses. The notch is up and toward the center main platform support.
20. Swing out the rear platform support arms and brace into position.
21. Disconnect the platform wing chain from under the trailer.
22. Stand up top lights.

**WARNING!** WHILE LOWERING THE SIDES OF THE PLATFORM, NEVER ALLOW ANYONE INSIDE OF THE TRUSSED AREA OF THE PLATFORM SUPPORTS. IF THE PLATFORM WOULD SUDDENLY DROP PEOPLE COULD BE INJURED OR KILLED. IF YOU NEED TO ENTER THIS AREA WHILE THE SIDES ARE PART WAY DOWN RAISE THE SIDE ALL THE WAY UP AND REATTACH TO THE TRAILER BEFORE ENTERING.

23. Remove two spreader turnbuckles from the top of the platform.
24. Connect the snatch block to the platform truss on the passenger side of the trailer.
25. The end of the cable should pin with a clevis to the ear on top of the center pole.
26. Insert the prop pole into pocket behind winch.
27. Connect second snatch block to one side of prop pole.
28. Connect black turnbuckle to prop pole and bolted ear on other side of center pole.
29. Snug up turnbuckle.
30. Disconnect front passenger side only of front spreader bar.
31. Unbolt rear most wing from trailer.
32. Swing out wing. Check that the inside wing for the other side of platform is still bolted to the trailer.
33. While pulling out on the outside main wing with a rope FROM OUTSIDE THE TRUSSED AREA OF THE PLATFORM SUPPORT FRAMES, slowly let the wing down. Stop and raise the wing if it catches on anything.

34. Lower platform to ground.
35. Turn winch around and connect snatch block to drivers side platform wing.
36. Disconnect cross cables on front platform spreader.
37. Unbolt inside wing and swing out.
38. Lower platform.
39. Remove platform trusses.
40. Setup fence and light poles.
41. Set up entrance ramps and platforms.
42. The double exit goes opposite the operators booth.
43. The single entrances go on each side of the ride at the wide points.
44. Start on each side of the operators booth with one long pole on the platform and one long pole with an ear on the side on the goose neck. short and long poles alternate after that.
45. The signs mount to the long pole on each side of the gooseneck and the ones on the gooseneck. The quartz lights go on the other long poles.
46. Install the signs on each side of the operators booth. the long pole on the platform gets an extension and the pole on the goose neck has an ear on the side to pin to the fence.
47. Remove the stands from under the rear seats, unpin the ear between the seats and swing around.
48. Pin the short sweeps to the spindle in two places.
49. Pin the swing around seat to the cabbage head.
50. Unpin and remove the pin over the top of the upper seat sweeps.
51. Connect grip hoist and lower seats. Use a bar to start the seats up to keep from breaking the shear pin on the hoist.
52. Remove stand from under the two main sweeps and swing out. Keep stand under rear sweep.
53. Pin lower main sweep.
54. Remove rear seep stand.

55. Use the hydraulic cylinder mounted in the trailer to raise each sweep and pin the top ears.
56. Use grip hoist to lower seats.
57. Connect turnbuckles between seats. Snug them only and tighten jam nut.
58. Open foottubs and install and pin foottub side plates.

**WARNING! NEVER OPERATE THE RIDE WITHOUT THE FOOTTUB SIDE PLATES INSTALLED AND PINNED.**

59. Install connector light panels and pin.
60. Remove ladder.
61. Connect seat unlock air lines and electric cords.
62. Remove all racks and loose items from ride.
63. Check seat lock operation on each seat before operating ride. Perform this check every day.
64. MINIMUM PASSENGER HEIGHT IS 42 INCHES.

## SAFETY CHECKS FOR SIZZLER

- A. On the small outside spindles, where the seat sweeps cross, check the channels for cracks. If found call the factory for instructions to repair.
- B. Check the donut around the small spindle shaft for cracks where the ears are welded to the donut. This ear has two seat sweep pipes bolted to it. If cracked, call for instructions.
- C. Check the top sweeps of the ride for cracks near the center pole. These cracks are made once in a while by the way the top sweeps are folded for travel. If they are in a bind when folded, and are forced into place by tightening the turnbuckles, they can crack. When the ride is opened and the sweeps pinned into place they are safe in operation, but the cracks should be repaired as soon as possible.
- D. There should be a turnbuckle between the movable seat sweeps, running from the bottom bolt to the other bottom bolt on both sides of the spindle. If you do not have these turnbuckles, order them now. They will take any side step out of the movable seat sweeps.
- E. The bottom sweeps that pin into the main center pole should be checked for wear. This wear can be noticed by a thumping sound as the ride rotates. If found the holes should be reamed to 1 5/16 and repinned.

SIZZLER  
OPERATOR'S INSTRUCTIONS

1. Turn on power to the hydraulic pump.
2. Be sure all the seat bars are open so the customer can enter the ride easily.
3. Collect all tickets as the customers enter on one side of the trailer.
4. If necessary help customers into seats and be sure the HEAVY, OR LARGE PERSON IS TO THE RIGHT SIDE OR THE OUTSIDE OF THE SEAT. Due to the centrifigal force of the ride the passenger is pushed to the outside of the seat. It is much more comfortable for them if the largest person is on the outside of the seat.
5. Check all safety bars to see that they are locked properly.
6. Be sure the seat lock switch is in the OFF position. This seat lock turns off automatically by a timer after 20 seconds, but, turn it off manually before the ride starts up.
7. Be sure the area around the ride is clear of passengers and assistants, or any item that may be hit by the seats as the ride rotates.
8. Push the button, or pull the handle to start the ride.
9. As the ride gets up to speed, WATCH THE PASSENGERS. If any of them try to standup, change positions with another passenger or start crying, STOP the ride immediately and take them off of the ride.
10. The start switch and start handle are both designed to be held by the operator at all times during the ride. When the operator takes his finger off of the button or lets go of the handle the ride will stop. DO NOT BYPASS OR IN OTHER WAYS DEFEAT THIS MECHANISM. IT IS FOR YOUR SAFETY AS WELL AS YOUR PASSENGERS.
11. After the ride has stopped, turn on the seat lock switch. This will unlock the seats and allow the customer to push the handle bar down and exit from the seat. HELP ANY PASSENGER THAT SEEMS TO BE HAVING TROUBLE.
12. Turn off the seat lock switch.
13. Start loading your next load of passengers.

The Sizzler has been designed for portability, customer attractiveness, and ease of operation. We have attempted to design a piece of equipment that can be operated with a Carnival or in an Amusement Park. One major asset of the Sizzler is its futuristic style seats, beautiful lighting and its extreme portability.

After setting up the Sizzler, a few things should be checked. First, that all the moveable sweeps are plugged in, and that the seat locks are operating properly on each tub. If the seat lock pin does not stick in approximately  $\frac{1}{4}$  inch into the brass seat iron, the pin should be removed and the alan set screw hole redrilled to allow plenty of penetration into the seat iron slot.

Check each seat lock pin to make sure that it moves in and out freely. If it should be gummed up, use WD-40 or a silicone lubricant to clean and lubricate the seat lock pin.

The Sizzler is equipped with a pneumatic time relay for the seat locks. This relay is set for 15 seconds on, generally this is time enough for everyone to push on their handlebar and get out of the seat. The reason for the relay is that an operator does not have to remember to shut off the seat locks, it will shut itself off. Only after the switch has been turned off and back on will the seat locks come back on. This prevents accidentally leaving the seat locks on during the operation of the ride.

Each time the Sizzler is started with the load, the operator should hand check each handlebar to make sure that the handlebar is locked securely. Also make sure that the larger person sits towards the outside of the seat. This is important as an adult can hurt a child while the ride is running, due to centrifugal force.

Next check that the hydraulic pump is rotating in the proper direction. Generally if the pump runs unusually quiet, it is rotating in the wrong direction. To reverse the electric motor, switch two (2) power legs to the motor and this will reverse the pump rotation.

Slowly rotate the ride to make sure that all objects clear all of the tubs and sweeps, especially the fence and the axle that has been removed from under the Sizzler Trailer.

If during the operation of the Sizzler, one of the tubs strike on object such as the axle or the fence, check and make sure that sweep, where it fastens to the spindle has not been damaged in anyway. Occasionally after striking an object the sweep will not show immediate failure and should be checked periodically for fractures on the welding or structural members of that seat and sweep.

After setting up the ride, make sure that the alan screws are adjusted on the moveable sweeps to take out any slack that is apparent. This is very important, especially due to the fact that the structural integrity of the short sweeps can be affected by the constant banging back and forth of bearings which is used to raise and lower the moveable sweeps. can be damaged and need replacement. A modification is available for the older model Sizzlers, which consists of two turnbuckles on each sweep to remove this slack. This modification is available by contacting our shop. If turnbuckles are used, just snug is all the tightening it needs to hold the sweeps in place. These turnbuckles are an easy way to make sure that the ride has been properly set up.

## SIZZLER

### WARNINGS

1. Each time the ride is operated, the operator should hand check each handlebar to make sure that the seat lock pin is fully engaged in the seat iron. If a seat lock pin is sticking, please clean and relubricate.
2. Never allow anyone to stand in the Sizzler seat while the ride is operating.
3. Never unlock the seats while the ride is turning.
4. Never allow anyone to stand on the ride while it is operating.
5. Never allow anyone to trade seat positions while the ride is operating.
6. The ride is equipped with a spring return push button for the rotation of the ride. The operator should not be allowed to jam this button down, or wire in a toggle switch or change anything that will allow the operator to leave the ride while it is running.
7. Always flip the seat lock switch to the OFF position before the ride is started.
8. Oil the hinge bolts on the nose of the Sizzler seats. This will prevent rust from building up and also after the ride has been moved from winter storage, will prevent the nose tub from being frozen into position and possibly causing the hinge bolt to be sheared off when the nose is forced down into the operating position.
9. Check each hinge bolt and nut weekly. If the nut is loose replace as soon as possible with a new lock nut.
10. Any tub in which the seat lock or hinge bolts are malfunctioning should be closed and not be used until that tub has been repaired.
11. On all older model Sizzlers, the axle is held on in front by two (2) clips for highway use. These clips should always be fastened going down the road, as the axle can flip out from underneath the trailer when the brakes are applied at highway speeds.

The Sizzler has been designed for reliability and safety of both the operator and the customer. As with any ride, the operator must pay strict attention to the customer while the ride is operating.

IMPORTANT!!! Instruct all operators in the following:

- a. No Standing
- b. Be sure handlebar is closed and locked.
- c. Do not try to trade seats.
- d. Heavy person to outside of seat.
- e. Check speed of ride - Not over 11 RPM of center pole.
- f. Turn off seat locks before starting ride.

This is an operational sticker that has been sent to all known Sizzler owners. If they are not the original owners they may not have received one. We will send one at no cost to any owner that requests one. It should be placed near the control switch or handle for the operator.

## CAUTION

### BEFORE STARTING RIDE

- 1) Turn off seat locks.
- 2) Check that each handlebar is locked.
- 3) Have heavy person sit to outside of seat.
- 4) All riders must have feet inside foot board.
- 5) Clear inside of fence of spectators.
- 6) Start ride.

If anyone tries standing up  
STOP ride!

Do not allow anyone to throw  
or catch objects while ride is  
operating.

If any failure occurs STOP ride  
immediately!

## OPERATING AMUSEMENT DEVICES - OPERATOR INSTRUCTIONS

The following are the correct loading (balance) procedures for amusement devices:

1. Every amusement ride must always be operated with a balanced load of passengers at all times.
2. The balancing rule is to ensure an even load on the ride's structure and mechanical drive, which in turn will cause less wear and tear and ensure a safer, longer life of the structure with less down time for adjustments and repairs.
3. In practical terms, consider the difference in driving a motor vehicle with balanced wheels as against unbalanced wheels, which causes vibrations and eventually wear and tear. The majority of operators have experienced driving a car with unbalanced wheels and the consequent results. Amusement devices are mostly large wheels and react the same as an automotive wheel when out of balance.
4. Although the out of balance load on some devices cannot be felt by the passengers or operator, it is still essential for the ride to be balanced.
5. On an extremely fast moving ride, it is essential that the ride be accurately balanced at all times.
6. Although it may not be strictly essential to balance slower revolving rides, it is still most desirable to achieve a balanced load, in the interests of the passengers and the owner of the ride, for increased safety and less "wear and tear".

## OPERATOR RESPONSIBILITIES

1. **HANDICAPPED PERSONS** - Persons who are physically handicapped must not be allowed to ride violent or fast moving rides. If the management of the amusement area allow handicapped to ride certain slow rides, the operator must ensure that the handicapped person is under the full control of an adult person who will ride with them and provide supervision during the ride.
2. **PROHIBITED PASSENGERS** - Operators should not allow a passenger on the ride who cannot be properly secured due to his size or if there is a malfunction to the securing device. Similarly, they must refuse service to a pregnant woman, or a passenger who is visibly ill, or under the influence of alcohol or drugs.
3. **CLEARANCE PRECAUTION** - Before operating the ride, it is important to ensure that there are no personnel around the ride structure or any exposed electrical components or other areas where there could be a risk of injury.
4. **ON-DUTY ATTENTION** - Insist that each operator remain in full control of the operating controls during operation of the ride with complete attention to the ride and passengers. Under no circumstances should the operator leave his or her position while the ride is in operation.  
  
If it does become necessary for the operator to leave his post at the controls, he must turn the ride off completely to ensure it does not accidentally start and injure passengers or staff.
5. **INSPECTION/CHECK LIST** - Operators must inspect the ride and complete a General Check List before each day's operation.
6. **DAILY WARM-UP** - The operator must always run the ride through several cycles before the first passengers are loaded. This warm-up without passengers is necessary to make sure the ride is safe and there are no problems mechanically not detected previously,
7. **PRECAUTIONS BEFORE AND DURING THE RIDE** - Never start the ride unless the operator or assistant is facing the ride and is in a position to observe the whole area because:
  - Patrons have been known to jump fences.
  - Patrons have been known to try to change positions while the ride is running.
  - Patrons have been known to "skylark" causing their own

safety and that of others to be put in jeopardy.

- The operator's assistant may wish to make a last minute adjustment and be put in a dangerous position when the operator puts the ride in motion.

8. SMOKING - Smoking is not allowed in the Gravitron. This includes the operator as well as the passengers.
9. LOOSE ITEMS - The area inside the Gravitron must be clear of any items that can fly out to the edge of the ride when it gets up to speed.
10. FOOD AND DRINK - It is recommended that no food or drink be allowed onto the ride.

CARNY TOWN.COM

## OPERATOR SELECTION AND INSTRUCTION

1. Select competent, mature operators, capable of understanding the function and use of amusement rides and their control.
2. Instruct each operator fully in the proper use and function of the ride he is to supervise, including:
  - a) Controls and procedures for normal and emergency operation.
  - b) Manufacturer's recommended maximum speed and load.
  - c) Manufacturer's recommended length of ride time and frequency of repeat rides.
  - d) Any foreseeable misuse of the ride as determined by the manufacturer or owner, or by special conditions such as weather, location, or crowds.
  - e) Each operator must have immediate availability of a manufacturer's Operator Manual for the ride he supervises.
3. Require each operator to inspect the ride he supervises, each day of the operation.
  - a) Determine that no portion of the ride is damaged, omitted or worn in such a manner that it is unsafe or that it may develop into an unsafe condition.
  - b) Report any irregularities to the superintendent or owner.
  - c) Do not operate the ride if any irregularities are found until such condition has been corrected.
4. Instruct the operator to allow no passengers to ride who are visibly ill, or under the influence of drugs or alcohol.
5. Instruct operators and attendants on the proper methods of securing passengers in the ride. Do not allow a passenger to board a ride if he cannot be properly secured because of his size or because there is a malfunction of the securing device.

STOP the ride immediately if any passenger is observed moving from their seat, turning upside down, or behaving dangerously, such as standing up.
6. Advise the operator against starting or operating the ride while any person (passenger, spectator, or employee) is in an endangered or unsafe position on the ride, or within the ride area.
7. Insist that each operator remain in full control of the operating controls during operation of the ride, and gives his full attention to the ride and its passengers.

8. Instruct the operator to let no other person, other than another trained operator, operate the controls of the ride, except those portions of the ride that specifically designed to be controlled by the passenger.
9. Advise the operator that factory-installed safety devices are not to be tampered with or removed.
10. Advise the operator of owner/supervisor procedures for assisting ill or injured passengers.
11. Instruct operators and attendants that patrons are required to secure all articles, such as keys, change, eye glasses, etc., which may become loose while riding.

CARNY TOWN.COM

## SAFETY REQUIREMENTS

The key to safety is well trained and supervised employees. Make certain that all employees know how the ride operates. The employees should have a good attitude towards safety and common sense.

REMEMBER, SAFETY MUST ALWAYS COME BEFORE REVENUE.

Do not neglect the employees' safety. Before starting the ride, be certain there are no personnel inside the fences or on the ride structure. Be certain all electricity is turned off whenever an employee might come into contact with electrical connections or components. Safety helmets should be worn by all personnel when erecting or disassembling a ride.

### GENERAL SAFETY GUIDELINES

The following is a list of a few general rules which should be adhered to by everyone. Remember that in the long run, the key to a safe and successful operation is to have well-trained and well supervised employees.

1. All work must be done by competent, qualified mechanics capable of understanding the function of the parts and their proper installation.
2. Inspect the ride each day of operation to determine that no portion of the ride is damaged, omitted, or worn in such a manner that it is unsafe, or that unsafe conditions may develop.
3. Perform manufacturer's recommended maintenance procedures at intervals and in the manner specified by the Operation and Maintenance Manual, in the following general areas:
  - a) Lubrication
  - b) Air, Hydraulic, and Electrical systems
  - c) Torquing of bolts
  - d) Wear of bolted or pinned joints
  - e) Adjustment and care of mechanical components such as; brakes, clutches, and air compressors
  - f) Passenger securing devices
  - g) All parts are present and installed
  - h) Operating and emergency controls
  - i) Factory installed safety devices
4. Study each job carefully to determine all hazards so that necessary safeguards can be taken.

5. Examine safety devices, tools, ladders, etc. before they are used to make sure they are in good condition.
6. Use the proper tool or equipment for each job. Ground all hand electric power tools before use unless the manufacturer advises otherwise.
7. Wear close fitting comfortable clothing when working on or close to mechanical apparatus or live electrical circuits. Avoid finger rings, jewelery, or other articles which may be caught in moving parts or come in contact with electrical circuits.
8. Protect your eyes by wearing approved safety glasses or goggles.
9. Wear hard hats at all times. When working in elevated areas, use a safety belt.
10. Where work is to be performed is hazardous, such as live electrical circuits, at least two men should work together.
11. If guards must be removed from equipment, make sure they are replaced before leaving the job.
12. Clean up each job and dispose of surplus materials.
13. Keep a record of parts replaced and date of replacement. Inform the manufacturer of any replacement requirements that are frequent or cause unsafe conditions.
14. Make modifications and additions as outlined in the manufacturer's Service and Safety Bulletins.

TABLE OF CONTENTS BY HEADING

Preface.....1  
Electric motor will not start.....3  
Electric motor runs then stops.....4  
Three-phase power check.....5  
Sparks and smoke from center-pole.....6  
Replacement of center-pole brushes.....6  
Ride is electrically "hot".....6  
Seat lights circuit-breaker kick off.....7  
Seat lights do not work.....8  
Seat locks do not work.....8  
Hoist will not start.....10  
Hoist will not lift trailer.....10  
Ride will not run.....11  
Ride makes squealing noise.....11  
Ride will not run at full speed.....12  
Fitting leaks.....13  
Hoses are wearing.....13  
Adjustment of pressure relief valve.....13  
Broken roller bearing.....14  
Chromed hole plugs pop out.....14  
Greasing the ride.....14

APPENDIX

- Hoist Operators Notebook
- Hydraulic pump specifications
- Ross motor exploded diagram
- Char-Lynn motor exploded diagram

The main areas to check when experiencing electric motor starting problems are:

1. Loss of 220 Volt three phase power
2. Magnetic switch problems.
3. Bad coupling or frozen pump.
4. Commutator brushes worn or broken.
5. Broken or shorting wiring.

The most frequent cause of a motor not starting is due to loss of three-phase power. The basic testing technique used to test for 220 Volt three-phase power is outlined on page of the electrical section. The testing for loss of a power line should follow this sequence:

1. Test at top and bottom of fuses in the main fuse box. If a line is missing, replace the bad fuse or get 220 Volt power for the ride.
2. After pushing the motor start switch, check the output of the magnetic switch. Once it is determined that the problem is in the magnetic switch, usually all that is needed is to clean the contacts and replace them if necessary.
3. Check at the center-pole commutator rings. If a line is missing here and the brushes are in good shape, then a line has been cut. When moving down the road, blocking or fence feet can fall into the hole at the base of the center-pole and cut up a line. Splicing will correct the problem.
4. Check at the box mounted on the motor. If power is present and the pump is not frozen, then the motor is bad and must be replaced.

A few things that will make trouble-shooting easier are:

When the motor hums and the pump is not frozen one line is missing.  
If there is no clicking sound when the magnetic switch is engaged, the switch is not getting power or is faulty.

Electric motor runs and then stops.

When an electric motor shuts off after 10 or 15 minutes of operation and can be started a few minutes later, then the overload protectors are kicking the magnetic switch off. If this happens when the ride is delivered and a 15 HP. 220 Volt motor is installed, the problem is either the overload protectors are too small or the ride is not getting the full 220 Volts required for operation. Measure across any two lines while the ride is running. Some generators produce 208 Volts and cause the motor to work harder to produce the same amount of horsepower. If the voltage cannot be turned up, a low voltage motor can be installed at the factory upon request.

It is possible that too light of overload protectors were installed and kick out too easily. These should be replaced with the proper sized ones. Another indication of too small overload protectors is when the ride is started in the morning it stops several times but later runs fine. This indicates one of two possibilities, either the overload protectors are too small and as the hydraulic oil warms up it requires less power to run the pump or that the hydraulic oil is too heavy for the climate that the ride is being used in. Care should be taken before deciding to install larger overload protectors. The operation of a motor with too large of protectors can cause the motor to burn up if the problem is not enough power or too heavy of hydraulic oil.

Procedure for 220 Volt three-phase power check.

1. Check for 220 Volts between lines A-B.
2. Repeat step 1 for lines A-C.
3. Repeat step 1 for lines B-C.

A reading of 110 Volts indicates that one of the two lines being measured is missing.

The determination of which line is missing is done by completing all three steps of the power check. The common line between the two 110 Volt readings is the missing line.

For example:

A-B	220 V.	A-B	110 V.
A-C	110 V.	A-C	220 V.
B-C	110 V.	B-C	110 V.

Line "C" is missing.

Line "B" is missing.

Power at the center-pole commutator ring is checked in the same manner.

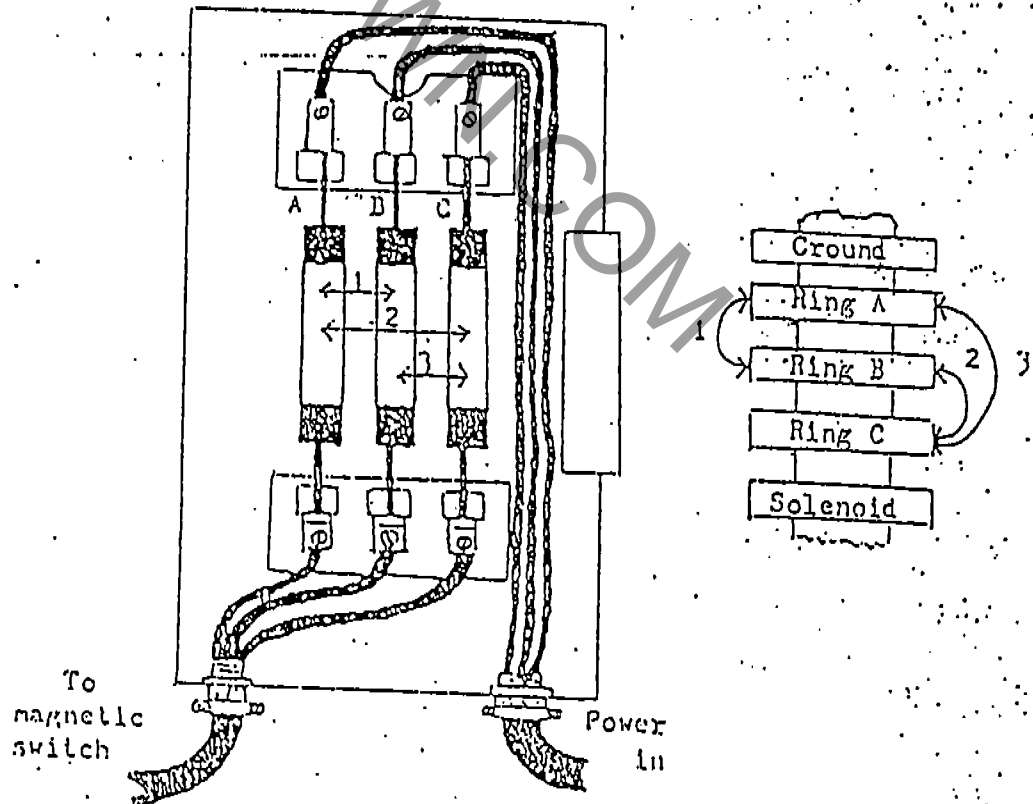

Sparks and smoke from the center-pole.

Obviously a short has occurred.

If this happens the reason is:

1. A brush has broken off and fallen between two commutator rings.
2. The rod holding the brushes in place has loosened up and allowed a brush to slip out and fall between two commutator rings.

Both problems require replacement of one or more brushes.

Replacement of center-pole brushes.

The first thing to do is cut off all power. After the center-pole brush cover is removed a dowel of about 3/8 of an inch diameter is placed under each brush pressure arm to prevent the good brushes from being damaged. Loosen the top and bottom rod-retaining bolt and tip the brush assembly away from the commutator rings. Remove the damaged brush and install a new one. After all the bad brushes are replaced carefully replace the brush assembly. Make sure that all the brushes are in the proper position and alignment and tighten down the rod-retaining bolts. Remove the dowels and check for proper contact on the commutator rings.

The ride is electrically "hot".

The cause of feedback through the neutral is a bad florescent ballast. Using a good voltage tester that will read at least in 20 Volt increments, switch off one section of lights. Measure from neutral to the frame and note the reading. Test every section of lights until the section with the largest voltage drop is found. Next, disconnect each group of lights on that section until the

The ride is electrically "hot".

voltage drops again, then each ballast in that group until the defective ballast is found. Replace the ballast and repeat the test procedure until the feedback voltage is at a minimum. When it is determined that the flourescents are all operating properly, the problem could be the transformer for the seat lights. The test procedure is the same.

Seat light circuit-breaker turns off.

The best way to discover the problem is to disconnect the power line to the seat lights at the brushes on the end of each sweep. On pre-1975 rides, the top brush is the seat light power line. On all rides produced or resold after 1975, the bottom brush is used for seat lights. If you are not sure which wire is which, the equipment ground is run with a short wire directly to the sweep frame. The equipment ground is usually on the opposite end of the brushes of the seat light brush. If the circuit-breaker still turns off after disconnecting all the seat light brushes, a wire is pinched or cut and should be replaced or splices. If the circuit-breaker does not turn off, the problem is in the seat wiring or commutator ring. A bad transformer will not cause a circuit-breaker to turn off. Usually the wiring has been cut. Disconnect all the seats until the bad wire is found to be good and the problem still persists, the seat light commutator ring is shorting to the spindle shaft. This only happens when the top brush is used for the seat lights. Rewire the top brush and ring for equipment ground and the bottom brush and ring for seat lights.

Seats lights do not work or one side does not work.

FIRST, check that the bulbs are not burnt out. Replace a suspect bulb with a known good one. After a particularly rough move an entire set of bulbs can be broken.

If one side is not working normally, the vibration during a move can cause the ground wire to loosen up. In one of the light bases mounted on the tail fin, a rivot holds a grounding wire to the back side of the light base. Soldering the rivit to the base will correct the problem. After these checks reveal that the problem is elsewhere, a check of the transformer is required. Remove the three bolts holding the brass seat lock plate in place and slide out the seat liner side panel. This will expose the transformer. If the transformer is bad, usually the paper core will be discolored and scorches. Check the input to the transformer for 110 Volts. Then check the output for 12 Volts. When the transformer is known to be good, check the lines to the lights. A tug on the ground wire and power line will check the connection on the tail-fin. To reconnect the wire to the tail-fin remove the three pop rivits holding the fin on and hook up the wire.

Seat locks do not work.

When a seat lock fails to work, check to see if the lock hums when engaged. If it does not hum and all the other locks work properly, a wire has been broken off the solonoid. Remove the seat liner side panel and reconnect the wire. If the lock hums but does not extend, remove the panel and check for free movement of the lock plunger. When free movement is achieved and the side panel is replaced, screw out the plunger with an alan wrench, while

Seat locks do not work. (Con't)

the seat lock is on until the plunger is even with the edge of the brass striker plate.

If none of the seat locks work, the problem is in the push pull switch or in the wiring. To check the wiring, consult the wiring diagram furnished with the ride. Disconnect the wire on the output side of the pneumatic time delay relay (left terminal) and touch to power. If the locks work, the push pull switch should next be jumpered across its two terminals. If the locks work, the push pull switch is bad. If no result, the pneumatic time delay relay is bad and needs to be replaced. For operation until a replacement can be installed, put a jumper across the two connections on the relay. CAUTION!! If the seat locks are left on for extended periods during loading and unloading, damage can result to the solenoids due to over heating.

Hoist pump will not start.

First, check the connections to the 12 Volt battery. The ground to the truck frame must be good. If the pump still will not run, short across the switch terminals. If the motor starts, replace the switch. When this does not start the motor, consult the "Operators Notebook" furnished at the back of this manual, for the troubleshooting procedure for the 12 Volt motor.

Hoist will not lift the trailer.

One of three things can cause the problem:

1. Low on oil.
2. Pressure-relief valve out of adjustment.
3. Pump going out.

First, MEASURE the oil level with a stick or tape. The oil should not be lower than two inches below the top of the tank.

If the hoist will raise the ride part way but can not quite make it high enough, the pressure relief needs to be adjusted. The procedure for adjustment is on page . If the valve has to be adjusted several times, the pump is going out and the "Operators Manual" should be consulted for rebuilding procedure of the pump section.

When working on the hoist, have the tractor hooked up in case a pressure line is cut or disconnected and causes the nose of the trailer to fall. Restrictors have been placed in the bottom of the hoist cylinders to keep the nose from falling too fast in case this should happen. Do not lower the nose of the trailer without the hoist pump on. This will cause the cylinders to draw in air and effect the later operation of the hoist.

Ride will not run.

First make sure all circuit-breakers are on. Check rotation of the pump. Most of the factory installed pumps turn counter-clockwise, looking from the shaft end. To reverse the electric motor rotation switch any two power lines.

MEASURE the oil level in the tank. The oil level should not be lower than two to three inches from the top of the tank. Check for oil turned on.

Remove the large hydraulic system cover-plate. With the pump off, check for operation of the electric solenoid valve. A dull clicking sound should be heard each time the valve is energized. If not, check for power at the bottom center-pole ring, when the start-push button is pressed. If power is not found, check for a faulty push button or bad wiring. If this is operating properly, check the wiring from the center-pole ring to the solenoid. One side of the valve is not used and the electric valve actuators can be switched if one is burnt out. Occasionally the brush will not make contact on the commutator ring due to wear of the brush and the brush pressure arm being too tight. The typical result is sporadic operation of the ride. Usually a tap on the brush pressure arm will correct the problem.

Ride makes a high pitched squeal when running.

Two things can cause the squeal: air being drawn into the system, or a restriction after the pump. When air is being drawn into the system, it is usually caused by too low an oil level in the tank. MEASURE the oil level. If foam is found in the oil, this would indicate that the level is too low. A restriction is caused by some part of the hydraulic

Ride makes a high pitched squeal when running. (con't)

system breaking loose and lodging in a line. This is very rare. If a pump should disintegrate, clean and inspect all lines from the pump to the filter. Disassemble the filter and check all openings for foreign particles. The only other component that can cause a restriction is the one-way valve used on older rides. The check part of the old-type valve was made of a phenolic material which could break out and lodge in the return line. If everything checks out all right, disconnect one end of the check valve and see if any thing is in the center. If not, clean out the line from the faulty check valve to the check valve on the return line. The ride can be operated without this check valve until a new one can be put on.

Ride does not run at full speed.

When a ride does not run at full speed, the following things should be checked.:

1. MEASURE the level of oil in the tank.
2. Check filter for amount of dirt and replace if necessary.
3. Check restrictor, placed in the lower left filling of the cushion valve, for foreign matter.
4. Check pressure setting when the ride is started for a reading of 14 - 1500 PSI. Adjust pressure relief to this pressure.
5. If a pressure of 14 -1500 PSI cannot be set then the pump is going bad and should be replaced. For a temporary repair, try removing the restrictor to bring the ride back up to the 11 - 12 RPM.
6. Check for a restriction using the procedure previously described.
7. The internal seals of the hydraulic motors can wear and cause internal leakage and loss of power. The installation of the seal kit can be done by any competent hydraulic repair shop. Exploded diagrams are furnished for this.

Fitting leaks.

When the ride is first delivered, all fittings should be tightened up. Do not tighten the swivel fitting excessively. One-quarter turn after snug is plenty. After the first 300 miles of moving, all fittings should be checked again.

Hoses are wearing.

Wrap all the wear spots with a piece of inertub and clamp with a hose clamp.

Adjustment of pressure relief valve.

Remove acorn cap. Loosen the locking nut. To increase the pressure, screw the stud in and out to reduce the pressure.

### Broken roller bearings.

The roller bearing outer race can break and drag on the spindle pipe as the seats are raised for moving down the road. Repair calls for replacement of the bearing and adjustment of the eccentric nut to push the sweep about an eighth of an inch away from the spindle pipe. The cause of the bearing breaking is due to slack in the adjustment bolt that holds the sweep snugly against the spindle pipe. Adjust these bolts each time the ride is moved.

### Seat nose plugs pop out.

The reason for the chromed hole plugs popping out is normally vibration. The other reason is, the bolt that the nose hinges on has loosened. Tighten the bolts as soon as possible. The bolts can work out and let the nose drop down causing a great deal of damage during operation of the ride.

### Greasing the ride.

There are three places to be greased on the center-pole. One in the top bearing under the top weather protector plate, one half way down the center-pole next to the side cover plate, and one at the base of the center-pole next to the pressure relief valve. The top bearing should be greased with one shot of grease every other week, and the other two should get a few shots every week.

All pillow block bearings at each end of the spindle shafts, should get one shot every other week. These are sealed bearings and do not need to be filled with grease.

## REPLACEMENT OF BOLTS

During normal maintenance practices, it is necessary to replace some bolts. They work loose because they have not been checked periodically, or they become lost when they are removed to repair some component. The points we wish to stress are the following:

Wisdom Mfg. uses only grade 5 bolts or better.

Bolts are identified by markings on the bolt head. Bolts without markings are generally grade 2 or 3 (common hardware store variety) and are not strong enough to be used on amusement rides in high stress areas.

When replacing any bolt, always use an equivalent or stronger bolt. Higher numbers mean stronger bolts.

NOTE: There are some bolts available above grade 8; however, these bolts are not to be used for general purposes. They are extremely brittle and are designed for special applications.

If trouble is encountered with bolts working loose, check the tightness according to the torque chart.

If certain bolts continue to work loose, remove the bolts and inspect the threaded holes. If threads are in good condition, clean the hole out with a non-oil base solvent and blow dry and apply "loctite" to the threads. After doing this, install new washer and bolt and torque as per the chart.

### BOLT TENSIONING TORQUE

1. All tensioning pressures are for grade 5 bolts which have a tensile strength of 50 tons per square inch.
2. Bolts that are used continuously for portable ride erection should not be tensioned to maximum torque unless instructed to do so or they are in a high stress area.
3. Bolts tensioned to maximum torque should not be continuously reused and should be replaced with new bolts of equivalent strength.
4. Caution should be exercised in applying torque because in some cases, it may not be possible to utilize all the torque a bolt will stand because of distorting surrounding parts.
5. Lubricate bolts when using with SAE 30 oil or an approved anti-sieze compound.

CAUTION; Torque values are given for steel bolts and steel nuts screwed into threaded holes in steel. Be certain threaded parts are not aluminium, brass, or other soft alloys.

BOLT TORQUE CHART

Bolt Size Grade 5	Max Torque ft.lbs.	Recommended Torque Reusable Bolt ft.lbs.	Recommended Torque Permanent Bolt ft.lbs.
U.N.C.			
3/8	27	24	26-28
1/2	66	55	60-66
5/8	130	95	125-130
3/4	230	180	220-230
7/8	370	290	360-370
1	560	480	540-560

Maximum torque listed is 65% proof load of bolt

NOTE: It is important to note the necessity of lightly oiling bolt before use as outlined above.

TORQUE METHODS- No torque wrench

Leverage Method:

The average 200-225 lb. mechanic, while standing on his feet, can apply a steady pull with his good arm (right arm if right handed etc.) of between 100 and 110 lbs. This pull is obtained without bracing his feet or free hand against any solid object such as a work bench or the machinery being worked on.

If a torque of any given value is desired, it becomes a simple matter of leverage. If the mechanic in question is tightening a 7/8" UNC thread bolt which recommends 520 ft lbs of torque, this value can be reached by using a heavy duty socket wrench and slipping a 5 ft. length of pipe over the handle of the wrench.

Thus, if the mechanic can exert a 100 lb pull, 5 feet times 100 lbs. would equal 500 ft lbs. Any other torque desired can be reached by simply dividing the desired torque value by approximately 110 to determine the length of the pipe or "cheater" bar that is needed.

## TURN OF THE NUT METHOD

This method applies only to bolts with UNC threads. If the bolt is shorter than eight times its diameter, tighten the nut until the pieces being joined are snugged up. Put a reference mark on the nut or socket wrench being used and tighten the nut, while preventing the bolt from turning, until the nut has been turned an additional  $1/2$  of a turn. If the bolt is longer than eight times its diameter, proceed as above but tighten the nut  $3/4$  of a turn. This will apply a preload to the bolt that will be very close to the same value that would be achieved if a torque wrench had been used.

CARNYTOWN.COM

## PNEUMATIC TIRES ON AMUSEMENT DEVICES AND SUPPORT VEHICLES

- \* It is strongly recommended to carry a quality spare tire and wheel for every type you have in operation, and inflated to pressure.
- \* Check pressures regularly on all tires in operation and maintain to manufacturer's recommendations.
- \* Unless unavoidable, it is strongly recommended that repairs or the fitting of new tires to rims be carried out by experts or a recognized tire dealers using correct equipment.

### \*\*\*CAUTION

Respect the potential power and explosive force of air under pressure. Serious accidents have resulted from lack of awareness of the explosive potential of compressed air. Respect it as you would DYNAMITE.

The following pages of guidelines, safety precautions and procedures of tire changing are included to make all operators aware of the dangers that can be encountered by neglecting care and safety in handling tires and compressed air.

## TIRE SAFETY - MOUNTING/DEMOUNTING

The following guidelines and safety procedures are intended to be used for reference only. Procedures will vary for different tire mounting equipment and different types of rims. If at any time an uncertainty exists about the method of assembly or component parts or use of equipment, consult specific equipment manuals.

The following precautions apply generally for all types of tires. In addition, each section emphasises specific precautions for each particular type of tire.

### \*\*\*WARNING\*\*\*

FAILURE TO OBSERVE THE PRECAUTIONS OUTLINED IN THIS SECTION MAY RESULT IN FAULTY POSITIONING OF THE TIRE AND/OR RIM PARTS CAUSING THE ASSEMBLY TO BURST WITH EXPLOSIVE FORCE SUFFICIENT TO CAUSE SERIOUS PHYSICAL INJURY OR DEATH.

### CORRECT PROCEDURES- Do it this way.

1. Make sure that all Rims are in good condition for use - not damaged, dented, or deformed.
2. Remove valve core and exhaust all air from the tire (or tires in the case of a dual assembly) before demounting. Probe the valve stem with a wire as a final check to make sure the valve is not plugged. Do not stand in front of valve opening as dirt particles may be blown into your eyes.
3. Block vehicle in a positive manner so it cannot roll forward or backward after it is jacked up.
4. Place large hardwood blocks under the jack, regardless of how hard or firm the ground appears.
5. Place safety jacks, or crib up with blocks at an appropriate place under the vehicle, in case the jack slips.
6. Check rim diameter to be sure it exactly matches the rim diameter moulded on the tire. If rim is multiple piece check component parts to see if they are made by the same manufacturer.
7. Clean and inspect used rim parts thoroughly.
8. Use new tubes and new flaps in new tires.

9. Inspect inside of tire for loose cords, cuts, penetrating objects, or other carcass damage. Scrap tires that are beyond simple repair. Remove dirt, debris, and liquids from the inside of tire before tube is installed.
10. Lubricate with approved rubber lubricant, such as thin vegetable oil soap solution.
11. Use a clip on chuck and extension hose with remote control valve and pressure guage, long enough to allow you to stand to one side, not in front of the assembly, during inflation.
12. Center tire properly on rim before inflating.
13. Secure lock wheel down, or place assembly in safety cage or portable safety device before attempting to inflate tire to seat beads.
14. Check for proper flange and lock ring seating.
15. Adjust air pressure to manufacturer's recommended cold operating pressure, after beads have been seated.
16. Inspect valve cores or proper air retention. Replace damaged or leaky cores.

FAULTY PROCEDURES - Do not do it this way

1. Don't work on tire and rim assemblies until you have reviewed safety practices and procedures.
2. Don't loosen lug nuts on duals until all air is exhausted from both tires. A broken or cracked rim part under pressure could blow apart and seriously injure or kill if lugs are removed before air is exhausted.
3. Don't ever apply heat or do repair work on an inflated tire, rim, and wheel assembly. Heat can increase air pressure to a level sufficient to burst the tire or rim.
4. Don't reinflate a tire that has been run flat or seriously under-inflated without demounting the tire and checking the tire and tube for damage.
5. Don't mix rim parts of different manufacturers unless such use is approved by those manufacturers.
6. Don't attempt, under any circumstances, to rework, weld, heat, or braze rim parts. Replace damaged parts with the same size, type, and make.

7. Don't reuse tubes or flaps that have buckled or creased.
8. Don't use a tube in a tire larger or smaller than that for which the tube was designed.
9. Don't inflate beyond recommended bead seating pressure. Don't stand over tire when inflating.
10. Don't transport fully inflated tires mounted on multi-piece rims. Inflate only enough (10-15 PSI) to keep rim parts in place. Inflate tires to correct operating pressure only after tire and rim assembly have been fastened in place, all lug nuts properly torqued, and rim parts rechecked for proper fit.
11. Do not substitute petroleum based lubricants, silicon or anti-freeze for approved rubber lubricants.