

MFG: WISDOM COMPANY  
NAME: RAIDERS  
TYPE: ATTRACTION

# RAIDER

WMI Industries, Ltd.  
P.O. Box 5000  
Sterling, CO 80751  
303-522-7515

# TABLE OF CONTENTS

Raider Set Up	2
Daily Check List	5
Safety Requirements	8
Operator Instructions	7
Operator Responsibilities	10
Operator Selection	11
Replacement of Bolts	12
Pneumatic Tires	14

## RAIDER SET UP INSTRUCTIONS

1. Disconnect truck and level trailer.
2. Fold down the jack stand on the front of the trailer and pin in the braces. Tighten both screw jacks.
3. Swing out the air slide platform on the side of the front tower and install the lower brace only.
4. Pin in the air castle roll out tracks and braces for the air castle cart. Level the tracks.
5. Roll out the air castle cart. Pin to trailer. Raise both castle end frames and install the three side upright frames and the two upper connecting frames.
6. Raise rear tower about 5 feet.
7. Connect the 12 foot cable from the top of the front tower to the end of the bottom slide section. Raise bottom section of slide by hand until it falls over center and is tight against the cable.
8. Raise front tower all the way up, fold down jack stand, and install braces. The screw jacks are not necessary at this time.
9. Disconnect cable from bottom slide section.
10. Lower rear tower to floor.
11. Assemble top floor of rear tower. All upper spreader bars, posts, and fences can be installed at this time. Safety key all pins. Raise tower 2 to 3 feet off the trailer to install diagonal upper brace.
12. Connect the side net cables to ear on the posts for the bridges. See drawing.
13. Raise rear tower all the way up. Fold down the jack stand and install braces. Leave screw jacks loose.
14. Lower front tower and assemble top floor. All upper spreader bars, posts, and fences can be installed at this time. Safety key all pins.
15. Connect the side net cables to the ears on the upright posts. See drawing.

**CAUTION: SIDE NETS CAN SNAG ON BRIDGE EYE BOLTS WHEN LIFTING.**

16. Connect the cable from the top of the front tower to the ear on the middle section of the slide.
17. Unpin the top and bottom of the top slide section on rear tower. Roll upper end of slide all the way forward. Pin long jack stand to the end of the hanging slide section.
18. Use two wedge pins and the short chain with the ears welded to it. Pin one end of the chain to the center hole on the middle slide section. Push up the end of the hanging slide section until you can pin the other end of the chain.
19. Raise the front tower raising both sections until the long jack stand can be pinned in place.
20. Pin the short jack stand to the middle slide section.

21. Lower the middle section of the slide, remove the connecting chain and pin the sections together. Pin and wedge together.

22. Pin jack stand on lower section of slide to the trailer.

**NOTE: If too much lifting pressure is kept on the middle section of the slide the lower edge of the seam will stick up. Loosen pins to allow the slide to drop down and tighten.**

23. Raise or lower rear tower until the upper end of the slide can be pinned to the tower.

24. The rear tower is now positioned. Tighten all three screws.

25. Disconnect the cable on the middle section of the slide.

26. Stand up the front tower.

27. Pin and wedge the lower section to middle section of slide.

28. Set up fence on air slide platform and install second support brace.

29. Connect the upper end of air slide trusses to the fence. Raise or lower tower until the trusses can be pinned to castle end frames.

30. Tighten the three screw jacks under front tower.

**NOTE: When both towers are up it will take awhile for the hydraulics to pump the last tower to an upright position.**

31. Install both 3/4" cables and turnbuckles under the trailer and connect to each tower ear. Tighten the turnbuckles. At the rear of the trailer, the cables should go under the axle for one cable and the angle iron for the other. Both cables should go under the round pipe on the front trailer jack stand.

**NOTE: If the towers shake excessively when customers are on bridges, tighten these cables.**

32. Connect lowest 3 spring clips on the air slide tube to the three lower eye bolts on the trusses.

33. Connect the blower to the air slide and turn on. The upper part of the air slide will flip over into position. Connect all remaining spring clips. The end of the air slide will protrude into the castle frame about 6 to 8 inches.

**NOTE: Be sure that the lower end is not caught on the frame exposing the steel where children can hit their head when sliding into the castle.**

**Be sure that the zipper is closed on all air bounces before operating the ride.**

34. Connect the blower to the air castle.

35. Spread out the bounce at the bottom of the fiberglass slide, connect the blower, and plug in. Tie the end of the bounce to the jack stand at the end of the fiberglass slide.

**NOTE: The bounce should overlap the end of the slide by about a foot.**

36. Screw down the two screw jacks on the end of the fiberglass slide.

37. Open end scenery panels and install braces.
38. Hang lower scenery panels.
39. Fold down entrance platform and connect ramp.
40. Set up fence around bounce.
41. Set up fence on entrance platform and ramp.
42. Set up fence o trailer.
43. Connect cargo net side cables to fence.
44. Hang quartz lights. Be sure that the 1" x 2" clips on the front two quartz light brackets protrude towards each other.
45. Install rainbows. The rear tower rainbow hooks on the top of the corner post and the quartz light bracket on the other end.
46. Install top canvas.
47. Plug in all quartz lights, rainbows, and fans.

NOTE: LAST TOP RING  
ON SIDE NET MUST BE  
HOOKED INTO CABLE CLEVIS.

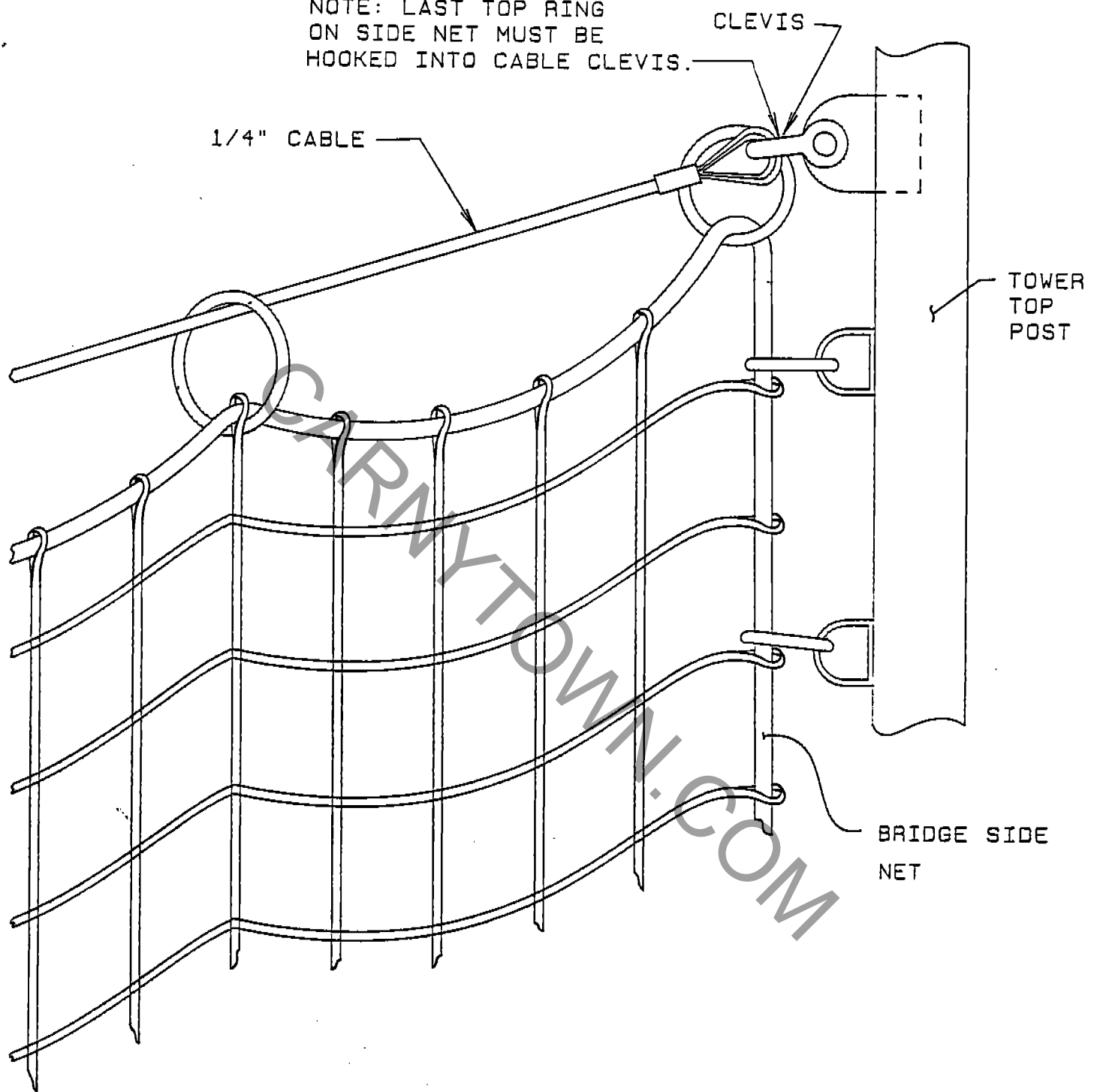

## RAIDER DAILY CHECK LIST

1. Check that trailer stands are tight.
2. Check that the jack stand screw jacks are tight.
3. Check that the jack stand brace pins are all installed and have safety keys.
4. Check that the under cable turnbuckles are tight.
5. Check the main truss cables for broken strands or kinks when assembling the ride.
6. Check that scenery panels are hooked.
7. Check that the scenery braces are safety keyed.
8. Check that the entrance platform is level and stable.
9. Check that rainbows, lights, and fans are plugged in.
10. Turn main switch "ON" in the electrical box at the back of the trailer.
11. Check that all fan switches are in the "ON" position.
12. Check that all bounces blow up and that the zippers are closed.
13. Check each bounce, air slide, and punching bag for cuts or tears.
14. If the air slide is cut or the air castle is cut to where it will not hold air the traffic can be detoured through the fence at the rear tower to bypass the air slide, cargo net, and air castle.
15. If the air bounce at the bottom of the slide is not usable the ride must be closed until it is repaired.
16. The cargo net should be tight with both side safety nets up and snug.
17. The air slide should protrude into the air castle 4 to 6 inches. The steel frame work should not be exposed in this area.
18. Suspension bridge side nets should be connected to all sections of the bridge planks.
19. The side nets should be connected to all the rings on the end posts.
20. Check bridge and side net cables for loose connections or broken strands.
21. Check that the cable turnbuckles on the bridges are locked.
22. Upper fence and post pins should ALL be installed and keyed.
23. Check that all the pins are safety keyed with the rounded part of the hair pin towards the traffic area of the walk way.
24. Check that there are no objects on the towers or bridges that can fall off and hit the customers.
25. Check the slide plastic for loose or protruding rivets.

26. Check the slide for loose pins and that the joints are not sticking up as you slide down the slide. (NOTE: THE SLIDE IS NOT TO BE LUBRICATED.) The plastic is self lubricating.
27. The air pillow at the bottom of the fiberglass slide should be tied or staked in place so that the end of the pillow is under the end of the slide.
28. Fence sections are required around the air pillow at the bottom of the fiberglass slide. Check that the end fence is against the bounce pillow. All other sections should be away from the pillow.
29. Warning signs at the top of the fiberglass slide and air slide should be legible and strictly adhered to by all operators and customers.
30. Do not allow anyone to carry any objects while going through the ride.
31. Do not allow horse play pushing and shoving by any customer.
32. Do not allow running on the ride or climbing on the fences or nets.
33. SMOKING IS NOT ALLOWED ON THE RAIDER.

**!WARNING!**

**UNDER NO  
CONDITION  
SHOULD  
LUBRICATION  
OF ANY KIND  
BE USED ON  
THE  
FIBERGLASS  
SLIDE**

## OPERATING AMUSEMENT DEVICES OPERATOR INSTRUCTIONS

The following are the correct loading (balance) procedures for amusement devices:

1. Every amusement ride must always be operated with a balanced load of passengers at all times.
2. The balancing rule is to ensure an even load on the ride's structure and mechanical drive, which in turn will cause less wear and tear and ensure a safer, longer life of the structure with less down time for adjustments and repairs.
3. In practical terms, consider the difference in driving a motor vehicle with balanced wheels as against unbalanced wheels, which causes vibrations and eventually wear and tear. The majority of operators have experienced driving a car with unbalanced wheels and the consequent results. Amusement devices are mostly large wheels and react the same as an automotive wheel when out of balance.
4. Although the out of balance load on some devices cannot be felt by the passengers or operator, it is still essential for the ride to be balanced.
5. On an extremely fast moving ride, it is essential that the ride be accurately balanced at all times.
6. Although it may not be strictly essential to balance slower revolving rides, it is still most desirable to achieve a balanced load, in the interests of the passengers and the owner of the ride, for increased safety and less "wear and tear".

## **SAFETY REQUIREMENTS**

The key to safety is well trained and supervised employees. Make certain that all employees know how the ride operates. The employees should have a good attitude towards safety and common sense.

**REMEMBER, SAFETY MUST ALWAYS COME BEFORE REVENUE.**

Do not neglect the employee's safety. Before starting the ride, be certain there are no personnel inside the fences or on the ride structure. Be certain all electricity is turned off whenever an employee might come into contact with electrical connections or components. Safety helmets should be worn by all personnel when erecting or disassembling a ride.

### **GENERAL SAFETY GUIDELINES**

The following is a list of a few general rules which should be adhered to by everyone. Remember that in the long run, the key to a safe and successful operation is to have well-trained and well supervised employees.

1. All work must be done by competent, qualified mechanics capable of understanding the function of the parts and their proper installation.
2. Inspect the ride each day of operation to determine that no portion of the ride is damaged, omitted, or worn in such a manner that it is unsafe, or that unsafe conditions may develop.
3. Perform manufacturer's recommended maintenance procedures at intervals and in the manner specified by the Operation and Maintenance Manual, in the following general areas:
  - a) Lubrication
  - b) Air, Hydraulic, and Electrical systems
  - c) Torquing of bolts
  - d) Wear of bolted or pinned joints
  - e) Adjustment and care of mechanical components such as; brakes, clutches, and air compressors
  - f) Passenger securing devices
  - g) All parts are present and installed
  - h) Operating and emergency controls
  - i) Factory installed safety devices
4. Study each job carefully to determine all hazards so that necessary safeguards can be taken.
5. Examine safety devices, tools, ladders, etc. before they are used to make sure they are in good condition.
6. Use the proper tool or equipment for each job. Ground all hand electric power tools before use unless the manufacturer advises otherwise.
7. Wear close fitting comfortable clothing when working on or close to mechanical apparatus or live electrical circuits. Avoid finger rings, jewelry, or other articles which may be caught in moving parts or come in contact with electrical circuits.
8. Protect your eyes by wearing approved safety glasses or goggles.
9. Wear hard hats at all times. When working in elevated areas, use a safety belt.
10. Where work is to be performed is hazardous, such as live electrical circuits, at least two men should work together.

11. If guards must be removed from equipment, make sure they are replaced before leaving the job.
12. Clean up each job and dispose of surplus materials.
13. Keep a record of parts replaced and date of replacement. Inform the manufacturer of any replacement requirements that are frequent or cause unsafe conditions.
14. Make modifications and additions as outlined in the manufacturer's Service and Safety Bulletins.

CARNYTOWN.COM

## OPERATOR RESPONSIBILITIES

1. **HANDICAPPED PERSONS** - Persons who are physically handicapped must not be allowed to ride violent or fast moving rides. If the management of the amusement area allow handicapped to ride certain slow rides, the operator must ensure that the handicapped person is under the full control of an adult person who will ride with them and provide supervision during the ride.
2. **PROHIBITED PASSENGERS** - Operators should not allow a passenger on the ride who cannot be properly secured due to his size or if there is a malfunction to the securing device. Similarly, they must refuse service to a pregnant woman, or a passenger who is visibly ill, or under the influence of alcohol or drugs.
3. **CLEARANCE PRECAUTION** - Before operating the ride, it is important to ensure that there are no personnel around the ride structure or any exposed electrical components or other areas where there could be a risk of injury.
4. **ON-DUTY ATTENTION** - Insist that each operator remain in full control of the operating controls during operation of the ride with complete attention to the ride and passengers. Under no circumstances should the operator leave his or her position while the ride is in operation.  
  
If it does become necessary for the operator to leave his post at the controls, he must turn the ride off completely to ensure it does not accidentally start and injure passengers or staff.
5. **INSPECTION/CHECK LIST** - Operators must inspect the ride and complete a General Check List before each day's operation.
6. **DAILY WARM-UP** - The operator must always run the ride through several cycles before the first passengers are loaded. This warm-up without passengers is necessary to make sure the ride is safe and there are no problems mechanically not detected previously.
7. **PRECAUTIONS BEFORE AND DURING THE RIDE** - Never start the ride unless the operator or assistant is facing the ride and is in a position to observe the whole area because:
  - Patrons have been known to jump fences.
  - Patrons have been known to try to change positions while the ride is running.
  - Patrons have been known to "skylark" causing their own safety and that of others to be put in jeopardy.
  - The operator's assistant may wish to make a last minute adjustment and be put in a dangerous position when the operator puts the ride in motion.
8. **SMOKING** - Smoking is not allowed on the RAIDER. This includes the operator as well as the passengers.
9. **FOOD AND DRINK** - It is recommended that no food or drink be allowed onto the ride.

## OPERATOR SELECTION AND INSTRUCTION

1. Select competent, mature operators, capable of understanding the function and use of amusement rides and their control.
2. Instruct each operator fully in the proper use and function of the ride he is to supervise, including:
  - a) Controls and procedures for normal and emergency operation.
  - b) Manufacturer's recommended maximum speed and load.
  - c) Manufacturer's recommended length of ride time and frequency of repeat rides.
  - d) Any foreseeable misuse of the ride as determined by the manufacturer or owner, or by special conditions such as weather, location, or crowds.
  - e) Each operator must have immediate availability of a manufacturer's Operator Manual for the ride he supervises.
3. Require each operator to inspect the ride he supervises, each day of the operation.
  - a) Determine that no portion of the ride is damaged, omitted or worn in such a manner that it is unsafe or that it may develop into an unsafe condition.
  - b) Report any irregularities to the superintendent or owner.
  - c) Do not operate the ride if any irregularities are found until such condition has been corrected.
4. Instruct the operator to allow no passengers to ride who are visibly ill, or under the influence of drugs or alcohol.
5. Instruct operators and attendants on the proper methods of securing passengers in the ride. Do not allow a passenger to board a ride if he cannot be properly secured because of his size or because there is a malfunction of the securing device.

**STOP the ride immediately if any passenger is observed moving from their seat, turning upside down, or behaving dangerously, such as standing up.**
6. Advise the operator against starting or operating the ride while any person (passenger, spectator, or employee) is in an endangered or unsafe position on the ride, or within the ride area.
7. Insist that each operator remain in full control of the operating controls during operation of the ride, and gives his full attention to the ride and its passengers.
8. Instruct the operator to let no other person, other than another trained operator, operate the controls of the ride, except those portions of the ride that are specifically designed to be controlled by the passenger.
9. Advise the operator that factory-installed safety devices are not to be tampered with or removed.
10. Advise the operator of owner/supervisor procedures for assisting ill or injured passengers.
11. Instruct operators and attendants that patrons are required to secure all articles, such as keys, change, eye glasses, etc., which may become loose while riding.

## REPLACEMENT OF BOLTS

During normal maintenance practices, it is necessary to replace some bolts. They work loose because they have not been checked periodically, or they become lost when they are removed to repair some component. The points we wish to stress are the following:

**WMI Industries, Ltd. uses only grade 5 bolts or better.**

Bolts are identified by markings on the bolt head. Bolts without markings are generally grade 2 or 3 (common hardware store variety) and are not strong enough to be used on amusement rides in high stress areas.

When replacing any bolt, always use an equivalent or stronger bolt. Higher numbers mean stronger bolts.

NOTE: There are some bolts available above grade 8; however, these bolts are not to be used for general purposes. They are extremely brittle and are designed for special applications.

If trouble is encountered with bolts working loose, check the tightness according to the torque chart.

If certain bolts continue to work loose, remove the bolts and inspect the threaded holes. If threads are in good condition, clean the hole out with a non-oil base solvent and blow dry and apply "loctite" to the threads. After doing this, install new washer and bolt and torque as per the chart.

### **BOLT TENSIONING TORQUE**

1. All tensioning pressures are for grade 5 bolts which have a tensile strength of 50 tons per square inch.
2. Bolts that are used continuously for portable ride erection should not be tensioned to maximum torque unless instructed to do so or they are in a high stress area.
3. Bolts tensioned to a maximum torque should not be continuously reused and should be replaced with new bolts of equivalent strength.
4. Caution should be exercised in applying torque because in some cases, it may not be possible to utilize all the torque a bolt will stand because of distorting surrounding parts.
5. Lubricate bolts when using with SAE 30 oil or an approved anti-seize compound.

CAUTION: Torque values are given for steel bolts and steel nuts screwed into threaded holes in steel. Be certain threaded parts are not aluminum, brass, or other soft alloys.

## BOLT TORQUE CHART

Bolt size Grade 5	Max Torque	Recommended Torque Reusable Bolt	Recommended Torque Permanent Bolt
U.N.C.	ft. lbs.	ft. lbs.	ft. lbs.
3/8	27	24	26-28
1/2	66	55	60-66
5/8	130	95	125-130
3/4	230	180	220-230
7/8	370	290	360-370
1	560	480	540-560

Maximum torque listed is 65% proof load of bolt

**NOTE:** It is important to note the necessity of lightly oiling bolt before use as outlined above.

### **TORQUE METHODS - No Torque Wrench**

#### Leverage Method:

The average 200-225 lb. mechanic, while standing on his feet, can apply a steady pull with his good arm (right arm if right handed, etc.) of between 100 and 110 lbs. This pull is obtained without bracing his feet or free hand against any solid object such as a work bench or the machinery being worked on.

If a torque of any given value is desired, it becomes a simple matter of leverage. If the mechanic in question is tightening a 7/8" UNC thread bolt which recommends 520 ft. lbs. of torque, this value can be reached by using a heavy duty socket wrench and slipping a 5 ft. length of pipe over the handle of the wrench.

Thus, if the mechanic can exert a 100 lb. pull, 5 ft. times 100 lbs. would equal 500 ft. lbs. Any other torque desired can be reached by simply dividing the desired torque value by approximately 110 to determine the length of the pipe or "cheater" bar that is needed.

### **TURN OF THE NUT METHOD**

This method applies only to bolts with UNC threads. If the bolt is shorter than eight times its diameter, tighten the nut until the pieces being joined are snugged up. Put a reference mark on the nut or socket wrench being used and tighten the nut, while preventing the bolt from turning, until the nut has been turned an additional 1/2 of a turn. If the bolt is longer than eight times its diameter, proceed as above but tighten the nut 3/4 of a turn. This will apply a preload to the bolt that will be very close to the same value that would be achieved if a torque wrench had been used.

## PNEUMATIC TIRES ON AMUSEMENT DEVICES AND SUPPORT VEHICLES

- \* It is strongly recommended to carry a quality spare tire and wheel for every type you have in operation, and inflated to pressure.
- \* Check pressures regularly on all tires in operation and maintain to manufacturer's recommendations.
- \* Unless unavoidable, it is strongly recommended that repairs or the fitting of new tires to rims be carried out by experts at recognized tire dealers using correct equipment.

### **\*\*\*\*CAUTION\*\*\*\***

**Respect the potential power and explosive force of air under pressure. Serious accidents have resulted from lack of awareness of the explosive potential of compressed air. Respect it as you would DYNAMITE.**

The following pages of guidelines, safety precautions and procedures of tire changing are included to make all operators aware of the dangers that can be encountered by neglecting care and safety in handling tires and compressed air.

## **TIRE SAFETY - MOUNTING/DEMOUNTING**

The following guidelines and safety procedures are intended to be used for reference only. Procedures will vary for different tire mounting equipment and different types of rims. If at any time an uncertainty exists about the method of assembly or component parts or use of equipment, consult specific equipment manuals.

The following precautions apply generally for all types of tires. In addition, each section emphasizes specific precautions for each particular type of tire.

### **\*\*\*\*WARNING\*\*\*\***

**FAILURE TO OBSERVE THE PRECAUTIONS OUTLINED IN THIS SECTION MAY RESULT IN FAULTY POSITIONING OF THE TIRE AND/OR RIM PARTS, CAUSING THE ASSEMBLY TO BURST WITH EXPLOSIVE FORCE SUFFICIENT TO CAUSE SERIOUS PHYSICAL INJURY OR DEATH.**

### **CORRECT PROCEDURES - Do It This Way**

1. Make sure that all Rims are in good condition for use - not damaged, dented, or deformed.
2. Remove valve core and exhaust all air from the tire (or tires in the case of a dual assembly) before demounting. Probe the valve stem with a wire as a final check to make sure the valve is not plugged. Do not stand in front of a valve opening as dirt particles may be blown into your eyes.
3. Block vehicle in a positive manner so it cannot roll forward or backward after it is jacked up.
4. Place large hardwood blocks under the jack, regardless of how hard or firm the ground appears.
5. Place safety jacks, or crib up with blocks at an appropriate place under the vehicle, in case the jack slips.
6. Check rim diameter to be sure it exactly matches the rim diameter molded on the tire. If rim is multiple piece, check component parts to see if they are made by the same manufacturer.
7. Clean and inspect used rim parts thoroughly.
8. Use new tubes and new flaps in new tires.
9. Inspect inside of tire for loose cords, cuts, penetrating objects, or other carcass damage. Scrap tires that are beyond simple repair. Remove dirt, debris, and liquids from the inside of tire before tube is installed.
10. Lubricate with approved rubber lubricant, such as thin vegetable oil soap solution.
11. Use a clip on chuck and extension hose with remote control valve and pressure gauge, long enough to allow you to stand to one side, not in front of the assembly, during inflation.
12. Center tire properly on rim before inflating.
13. Secure lock wheel down, or place assembly in safety cage or portable safety device before attempting to inflate tire to seat beads.

14. Check for proper flange and lock ring seating.
15. Adjust air pressure to manufacturer's recommended cold operating pressure, after beads have been seated.
16. Inspect valve cores or proper air retention. Replace damaged or leaky cores.

#### **FAULTY PROCEDURES - Do Not Do It This Way**

1. Don't work on tire and rim assemblies until you have reviewed safety practices and procedures.
2. Don't loosen lug nuts on duals until all air is exhausted from both tires. A broken or cracked rim part under pressure could blow apart and seriously injure or kill if lugs are removed before air is exhausted.
3. Don't ever apply heat or do repair work on an inflated tire, rim, and wheel assembly. Heat can increase air pressure to a level sufficient to burst the tire or rim.
4. Don't re-inflate a tire that has been run flat or seriously under-inflated without demounting the tire and checking the tire and tube for damage.
5. Don't mix rim parts of different manufacturers unless such use is approved by those manufacturers.
6. Don't attempt, under any circumstances, to rework, weld, heat, or braze rim parts. Replace damaged parts with the same size, type, and make.
7. Don't reuse tubes or flaps that have buckled or creased.
8. Don't use a tube in a tire larger or smaller than that for which the tube was designed.
9. Don't inflate beyond recommended bead seating pressure. Don't stand over tire when inflating.
10. Don't transport fully inflated tires mounted on multi-piece rims. Inflate only enough (10-15 PSI) to keep rim parts in place. Inflate tires to correct operating pressure only after tire and rim assembly have been fastened in place, all lug nuts properly torqued, and rim parts re-checked for proper fit.
11. Do not substitute petroleum based lubricants, silicon or antifreeze for approved rubber lubricants.



# MAN HO ROPE MFG. CO., LTD.



Manufactures & Exporters

1130-1, HWA MYOUNG-DONG BUK-KU.  
BUSAN, KOREA

P.O. BOX NO. 277 BUSAN  
TELEX NO. K03041, 83823 MANHO  
HEAD OFFICE TEL: 332-3131-9 (NINE LINES)

Sheet No. 87/MT/0072- 6

Date 2. FEB. 1987

## TEST CERTIFICATE

Customer : Messrs LANDMANN LIMITED.  
 Supplier : Messrs MAN HO ROPE MFG. CO., LTD.  
 L/C No. 605/11735 Order No. 2492  
 Commodity GALVANIZED AIRCRAFT CABLE.  
 Construction 7x19 IWSC Kind of Lay R.H.R.L Lube DRY  
 Specification MIL-W-83420D HOWEVER NOT Q.P.L LISTED AS PER 3.1.  
 Order Quantity 5,000 feet, mm Reel No. 54 - 73  
 Gross Weight Lbs, Kgs Net Weight 1,214.95 Lbs, Kgs

### TEST RESULT

Rope Dia 3/8 (Actual) 0.386 Inch, mm Preforming GOOD  
 Length of Lay 2.63 Inch, mm Color-Coding Identification GREEN THREAD.  
 Actual Breaking Strength of Wire Rope 16,450 Lbs, Kgs  
 Breaking Strength after Endurance Test (AT ROOM TEMPERATURE ONLY) 10,460 Lbs, Kgs  
 Stretch Test 1.36 % 80% Load Test NOT APPLICABLE  
 Nominal Dia. of Wire 0.0248 Inch, mm Ductility GOOD  
 Tensile Strength of Wires Min 197 Max 204 PSI, Kg/mm<sup>2</sup>  
 Weight of Zinc Coating 0.172 OZ/ft<sup>2</sup>, g/m<sup>2</sup> Adherence of Coating GOOD

### CHEMICAL ANALYSIS OF WIRE ROD

Charge-No.	C	Si	Mn	P	S
X 69788	0.75	0.19	0.52	0.022	0.008

MARKS

Chief of Quality Control Dept.



FILE  
RAIDER  
BCK Book

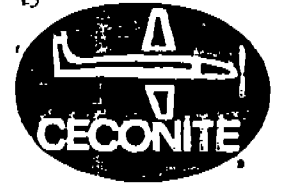

Denver Wire Rope  
671 E. 56th Street  
Commerce City, CO 80022

3815 MEDFORD STREET  
LOS ANGELES, CALIFORNIA 90063  
213 266-6651 • 266-2793

July 29, 1986

### TEST CERTIFICATE

Customer : Messrs CECONITE INC.

Supplier : Messrs MAN HO ROPE MFG. CO., LTD.

L/C No. I-18731 Order No. 1294

Commodity GALVANIZED STEEL WIRE ROPE.

Construction 6x19 HC Grade EIPS

Specification FS RR - W - 410D Coating LUBE: A-1

Order Quantity 5,000 feet, ~~mm~~ Reel No. 35

~~Gross Weight~~ Lbs, Kgs Net Weight 4,750 Lbs, Kgs

### TEST RESULT

Rope Dia 3/4 (Actual) 0.772 Inch, ~~mm~~ Preforming GOOD

Kind of Lay R.H.R.L Length of Lay 4.71 Inch, ~~mm~~

Actual Breaking Strength of Wire Rope 56,000 Lbs, ~~Kgs~~

Nominal Dia. of Wire 0.0488 Inch, ~~mm~~

Tensile Strength of Wires Min 192 Max 198 ~~PSI, Kg/mm<sup>2</sup>~~

Number of Torsion of Wires Min 32 Max 36 Times

Weight of Zinc Coating 0.356 ~~g/mm<sup>2</sup>~~ OZ/ft<sup>2</sup>

### CHEMICAL ANALYSIS OF WIRE ROD

Charge No.	C	Si	Mn	P	S
X 54245	0.75	0.20	0.47	0.020	0.005

### REMARKS

.....

.....

.....

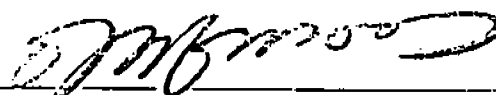
  
 Chief of Quality Control Section  
 Production Dept.

## RAIDER DAILY CHECK LIST

1. Check that trailer stands are tight.
2. Check that the jack stand screw jacks are tight.
3. Check that the jack stand brace pins are all installed and have safety keys.
4. Check that the under cable turnbuckles are tight.
5. Check the main truss cables for broken strands or kinks when assembling the ride.
6. Check that scenery panels are hooked.
7. Check that the scenery braces are safety keyed.
8. Check that the entrance platform is level and stable.
9. Check that rainbows, lights, and fans are plugged in.
10. Turn main switch "ON" in the electrical box at the back of the trailer.
11. Check that all fan switches are in the "ON" position.
12. Check that all bounces blow up and that the zippers are closed.
13. Check each bounce, air slide, and punching bag for cuts or tears.
14. If the air slide is cut or the air castle is cut to where it will not hold air the traffic can be detoured through the fence at the rear tower to bypass the air slide, cargo net, and air castle.
15. If the air bounce at the bottom of the slide is not usable the ride must be closed until it is repaired.
16. The cargo net should be tight with both side safety nets up and snug.
17. The air slide should protrude into the air castle 4 to 6 inches. The steel frame work should not be exposed in this area.
18. Suspension bridge side nets should be connected to all sections of the bridge planks.
19. The side nets should be connected to all the rings on the end posts.
20. Check bridge and side net cables for loose connectors or broken strands.
21. Check that the cable turnbuckles on the bridges are locked.
22. Upper fence and post pins should ALL be installed and keyed.
23. Check that all the pins are safety keyed with the rounded part of the hair pin towards the traffic area of the walk way.
24. Check that there are no objects on the towers or bridges that can fall off and hit the customers.
25. Check the slide plastic for loose or protruding rivets.

26. Check the slide for loose pins and that the joints are not sticking up as you slide down the slide. (NOTE: THE SLIDE IS NOT TO BE LUBRICATED.) The plastic is self lubricating.
27. The air pillow at the bottom of the fiberglass slide should be tied or staked in place so that the end of the pillow is under the end of the slide.
28. Fence sections are required around the air pillow at the bottom of the fiberglass slide. Check that the end fence is against the bounce pillow. All other sections should be away from the pillow.
29. Warning signs at the top of the fiberglass slide and air slide should be legible and strictly adhered to by all operators and customers.
30. Do not allow anyone to carry any objects while going through the ride.
31. Do not allow horse play pushing and shoving by any customer.
32. Do not allow running on the ride or climbing on the fences or nets.
33. SMOKING IS NOT ALLOWED ON THE RAIDER.