

Mighty Blue Grass

Wisdom

05316

MFG: WISDOM COMPANY
NAME: ORIENT EXPRESS
TYPE: KIDDIE

ORIENT EXPRESS

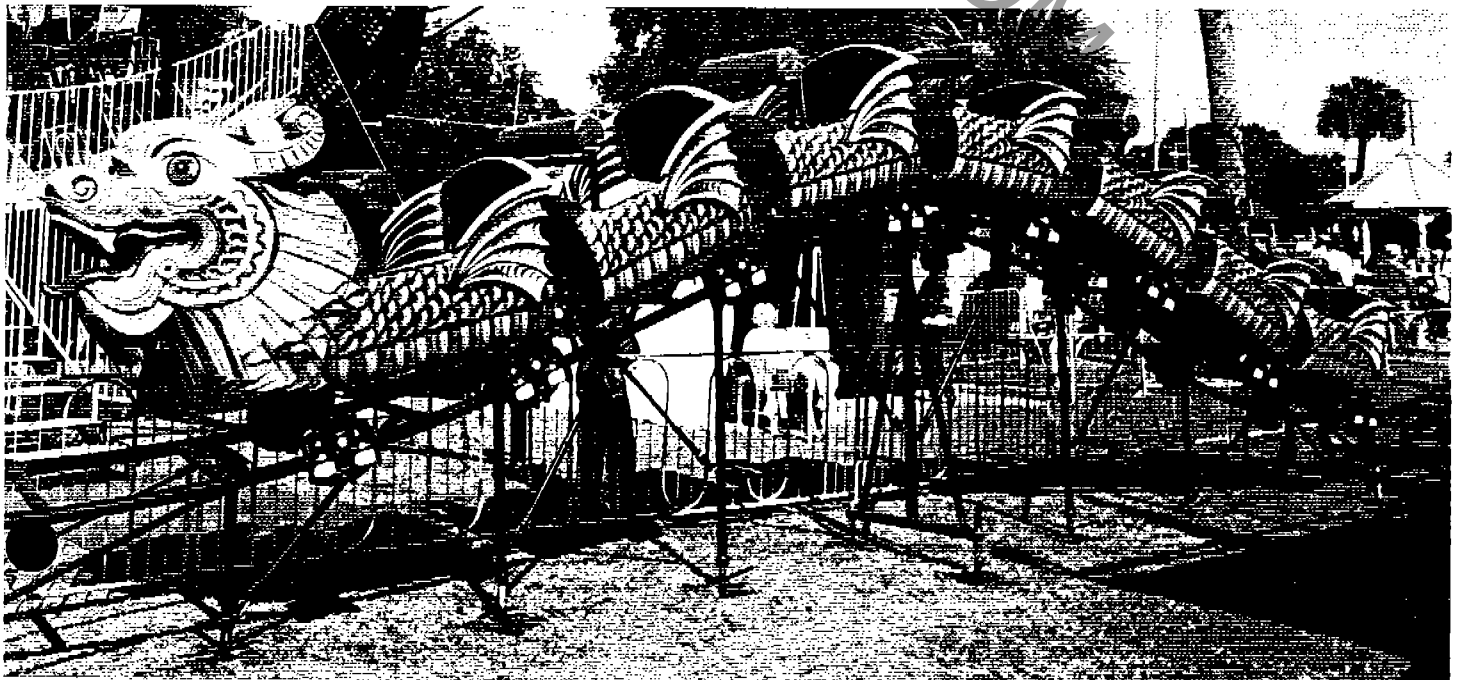
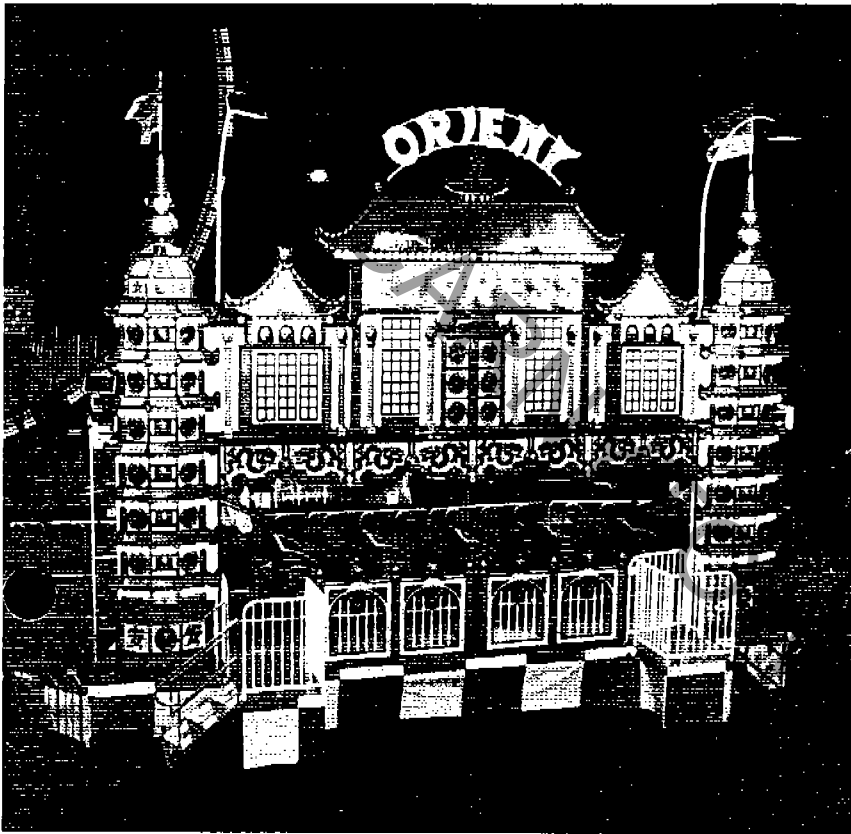

ORIENT EXPRESS

DESCRIPTION:

Roller Coasters are the #1 ride attraction in the amusement industry. Why? Kids of all ages love to ride them for the excitement and thrills! The Wisdom **ORIENT EXPRESS** is our hottest selling ride in the 90's. Unlike most kid's rides, the **ORIENT EXPRESS** adds scenery to the kiddie portion of the midway or park. It adds a touch of class and flair usually found only on major rides, and with comparable grossing revenues.

The **ORIENT EXPRESS** is decked out with a durable plastic oriental front which compliments the main feature—the greatest looking Chinese dragon you've ever seen. Youngsters race to take turns on this flashy piece. For added thrills, the **ORIENT EXPRESS** track design provides real coaster action. The operator runs the ride from a convenient vantage point on the platform.

Racheting lap bars make for fast loading times and the air unlock gives super fast unloading. Cycle times are incredibly fast. Parents and children can both ride in the large Oriental Dragon cars increasing your grosses and adding to the appeal of the ride. When it's time to set up or move, no problem! The **ORIENT EXPRESS** is extremely portable and is easily set up by two people in only an hour and a half!

With the Wisdom **ORIENT EXPRESS**, your return on investment and the kids' excitement will continue to grow for many years to come.

SPECIFICATIONS:

DIMENSIONS		POWER REQUIREMENTS		CAPACITY	
Fence to Fence	66' long x 28'6" wide	Drive Unit	11 HP / 3 Phase 8.25 KW	Cars	7 Cars
Trailer Mounting	28' long x 8'6" wide x 13'5" high 18,000 pounds gross weight Tandem axle or Single 10k axle	Electrical	188 10-watt Italian Lights 700-3W Italian Lights 11.25 KW 220V / 3 Phase	Seating	14 Adults or 21 Children
Options	Custom track designs available	Total	220 / 3 Phase 20.5 Kw	Hourly	650 Passengers

SET UP CONFIGURATION:

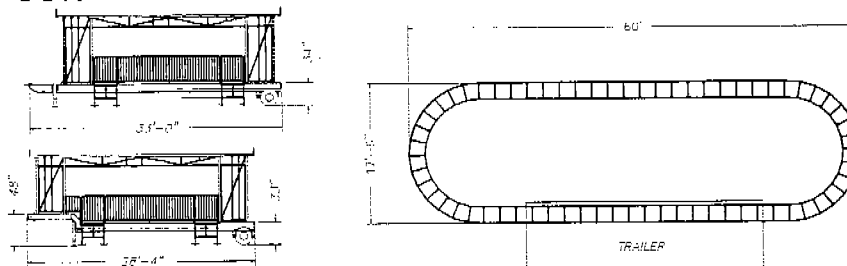

WISDOM INDUSTRIES, LTD.

PO Box 5000 Sterling, Colorado 80751
 (970) 522-7515 Fax (970) 522-2902 Customer Service Hot Line 1-800-634-6097

Carnivals • Family Entertainment Centers • Parks • Malls

**PORTABLE
ADULT
COASTER**

**WISDOM INDUSTRIES, LTD.
P.O. BOX 5000
STERLING, CO. 80751
970-522-7515
800-634-6097**

TABLE OF CONTENTS

Page 1.....	Specifications
Page 2.....	Assembling Instructions
Page 7.....	Adjustments
Page 8.....	Operating Instructions
Page 11.....	Post Set Up Inspection
Page 13.....	Warning before Starting Ride
Page 14.....	Daily Check List
Page 16.....	Emergency Procedures
Page 17.....	Lap Bar Inspection & Lubrication Schedule
Page 18.....	Lubrication Schedule
Page 19.....	Lubrication Diagram
Page 20.....	Safety Requirements
Page 22.....	Operator Responsibilities
Page 24.....	Operator Selection & Instruction
Page 26.....	Operator Instructions
Page 27.....	Replacement of Bolts
Page 29.....	Pneumatic Tires
Page 30.....	Tire Safety

PORTABLE ADULT COASTER

This "Operation Manual" has been written for the benefit of the ride operator and owner. **WISDOM INDUSTRIES LTD.** advise all ride operators and owner to read this manual before operation.

INTENDED USE

The equipment herein described is intended to be used by a commercial operator to provide a service to the buyer's customers. As a commercial operator, the buyer agrees to operate and maintain the equipment for its intended use in a professional and competent manner as per Wisdom Industries, Ltd. recommendations and instructions, industry and governmental standards, and good commercial practices, using professional and competent mechanics and operators. If at any time, and for any reason the equipment cannot be adequately and safely operated for its intended use, the buyer agrees not to operate the equipment until proper repairs or corrections are made.

SPECIFICATIONS

NUMBER OF SEATS7 seats
CAPACITY	3 children per car
.....	2 adults per car
CAPACITY.....	350 per hour
RIDE DURATION3 ride cycles
LOADING	2 children per car
.....	1 adult+1 child per car
MINIMUM PASSENGER HEIGHT.....	36 inches
<small>(Guests between 36" and 48" must be accompanied by a responsible person)</small>	
MAX WEIGHT/CAR.....	340 Lbs.
MAX TOTAL PASSENGER WEIGHT/RIDE	2380 Lbs.
SPEED.....	2 RPM
SET UP AREA.....	Varies with track shape
MOTOR POWER.....	5-5HP 3 Phase drive motors
ELECTRICAL.....	30 KW 100 AMP/220 Volt
.....	3 Phase 60 HZ

SETTING UP THE PORTABLE ADULT COASTER

1. Pull the trailer onto location.
2. Review the layout drawing to allow sufficient room and clearance for the track, fence and steps. Position the trailer accordingly.
3. Disconnect the truck from the trailer.
4. Place 2 tall adjustable trailer screwjacks under the back 2 corners of the trailer. Screw up to level across the back of the trailer.
5. Adjust the front landing gear jacks until the length of the trailer is level. Adjust the front landing gear jacks until the width of the trailer is level.
6. Unload the square jackstand sandplates. Place 2 for each jackstand in the approximate location where the track jackstands will be located.
7. Hook the steps up on the back side of the ride trailer to assist in carrying the track sections off of the ride.
8. Locate track section #26 and #27, pin to the track at the rear of the trailer.
9. Install jackstand #26 under the track.

NOTE: Use a 1/2" brace pin in the center of the jackstand to hold the jackstand in position under the track until the next piece of track is installed.

WARNING: Remove all these 1/2" pins before operating ride.

10. Install track section #26 to #25, pinning the end #26 to the same #26 on the section just installed.
11. Put in two 5/8" track pins & wedges into the two ears on the track.
12. Install the wedges into the track pin slot so that the narrow end goes through the notch in the jackstand support plate and install a "R" clip from the outside edge of the track towards the center of the track for each pin.

13. Tighten snugly with a hammer. Do not over tighten.
14. Place 2 of the sandplates underneath each screw adjuster on the jackstand.
15. Continue assembling track and jackstands in reverse order. Install diagonal braces as you go. Stop when you reach track #18.
16. Start at the front end of the trailer with track section #1-#2. Pin it to the end of the section which is welded at the front end of the trailer.
17. Place jackstand #2 underneath the end of the track numbered #2 and install a 1/2" pin to hold the jackstand.
18. Continue assembling the track. Pin each track section and installing diagonal braces as you go.

NOTE: Place a sandplate under each screw adjuster as you go.

19. After assembling the spiral. Install the spider in the spiral.
20. Pin the spider braces to the bottom of the jackstands.
21. Hook the other end of the brace to the spider center. Leave the turnbuckle loose.
22. Adjust spider up and down until the rods are close to level.
23. Install the diagonal braces from the spiral jackstands to the trailer frame.

NOTE: It is easiest to install these braces before making the final connection at the jackstand #18.

24. Finish assembling track.
25. Snug up the spider diagonal braces.
26. Tighten jam nuts on the spider turnbuckle.
27. Check all jackstands, track pins, diagonal braces for tightness and installation of all the pins.

27. Adjust each jackstand up and down until the seam on the track joint is even.
28. After all jackstands have been adjusted. Tighten the lock nuts on the jackstand screw adjusters.
29. Set up the fence around the ride.

NOTE: Allow a minimum of 3 feet between the side of the track and the fence.

30. Unpin and lower the train down into the station.

DANGER: Do not allow anyone to stand on the track behind the train.

31. Install the kicker motors under the track curved sections. Use two 5/8" slotted pins & wedges at the rear of the kicker motor and a single "L" pin at the front where the 2 spring adjusters are.
32. "R" clip all pins & wedges.
33. Pull out the cables for the kicker motors from near the operator's stand and plug into each kicker motor.
34. Install the bally cloth around the trailer.
35. Move the steps to the front of the ride.
36. Hook the steps onto the trailer.
37. Adjust steps so there is no more than 8" between the ground and the first tread.
38. Install both hand rails on each step.
39. Check that the steps are secure and do not wobble.
40. Use two 1/2 X 2" -grade 5-bolts and nuts, connect the center pipe on the track spiral and down ramp flanges.

NOTE: You may need to use a drift pin or adjust the screwjacks up and down to align the center pipe on the spiral and down ramp flanges together.

41. Stand up the top scenery. Raise one section at a time and install the diagonal braces. "R" clip both end of the scenery braces as they are installed.
42. Swing around the 2 quartz lights, mounted on each end of the canopy. Pin in position so they shine back on the plastic scenery front.
43. Connect the main power to the ride.
44. Check the motor operations for proper rotation.

NOTE: If the trailer motors operate in the proper direction and the kicker motor is in the wrong direction, then switch 2 of your main input leads, which will reverse your kicker motors. If all motors run backwards switch two wires on the main lead.

45. Turn on the air compressor. Check for proper pressure. (110 lbs. maximum 90 lbs. minimum)
46. Check the handlebars for proper operation for locking and unlocking.
47. Check that the track is clear of any cables and pins.

WARNING: Be sure to remove all 1/2" pins used to hold the jackstand during assembly from the center of each jackstand before operating the ride.

48. Check that all wedges are tight and in the notch on the jackstand plate and have "R" clips installed.
49. Check that all diagonal braces are installed.
50. Run the ride.
51. Check the brake for proper operation.
52. Run the ride several times.

53. Check the adjustment of the jackstands and joints.

54. Check tightness of pins & wedges.

NOTE: Do not over tighten wedges.

55. Check adjustment of the wheels under the cars.

56. Remove all the racks from the trailer and make sure there is nothing that can be a trip hazard. Never allow anyone in the center of the ride while the ride is operating.

CARNYTOWN.COM

ADJUSTMENT OF THE MAIN AND KICKER WHEEL DRIVE TIRES

1. Push the cars over the tire, so the tire is in the center of the car.
2. Adjust the two adjusting screws until the tread on the tire is just pushed flat against the plate.
3. Lock the jam nuts to hold the adjustment.
4. Test run the ride with a full load.
5. If the tire slips adjust the tire up until the tire will not slip.
6. Repeat for the each kicker wheel.

ADJUSTMENT OF THE SOFT START ON THE RIDE.

1. If the ride starts with a jerk. Turn down torque adjustment on the electronic soft start.
2. If the ride is not up to speed by the time the first car reaches the Up Ramp Kicker Wheel. Reduce the acceleration time.

ADJUSTMENT OF THE BRAKE

1. If the brake tire locks up when the cars enter the station.
2. Loosen the screw on the brake resistor and slide the adjuster away from the wires. Retighten.
3. If the brake will not stop the train correctly, raise the slide on the brake resistor closer to the wires. Retighten.
4. If the tire will not lock up no matter who the resistor is adjusted. Adjust the brake slack adjuster.
5. Adjust through the small slot on the back of the brake backing plate with a screwdriver.
6. The tip of the screwdriver turns a small wheel that screws the slack adjuster out and in
7. Repeat adjustment until the train stops correctly.

OPERATING THE PORTABLE ADULT COASTER

1. Load passengers. To ride this ride the passenger must be at least 36" tall. Any guest taller than 36" but shorter than 48" must be accompanied by a responsible person.
2. Passengers must sit facing forward in the seat with both hands and legs inside the car and with feet on the floor. They must not sit sideways in the seat. Larger passengers should be seated on the outside of the ride (toward the platform during loading).
3. Lower the lap bar into the passenger's lap before starting ride.

WARNING: Each lap bar **MUST** be checked by the operator by lifting on the bar by hand before starting the ride to check lock mechanism.

4. If a lap bar is raised to allow passengers to switch position, the lap bar must be checked by hand again before starting the ride.

WARNING: Do not use car if the lap bar is not working properly.

ALL LAP BARS MUST BE DOWN BEFORE STARTING RIDE.

5. Check that the entrance and the exit gates are closed.
6. Be sure ride area and inside fenced area around ride is clear of people before starting ride.

NOTE: No one is allowed to stand inside the fence while the ride operates.

7. Go to the control console and turn on the "Key Switch".
8. To start the ride, push and hold the "Ride Start" button until the last car has passed over the last drive wheel. The "Ride Start" button must be pushed and held each time the ride passes through the station so that the ride will be able to climb the incline and continue on the next ride cycle. If the "Ride Start" button is not depressed as the ride passes through the station, the ride will stop while attempting to climb the incline and roll backwards toward the station.

WARNING: Use constant vigilance while the ride operates.

WARNING: When the ride is running, be alert and watch for children that may be slipping, falling in their seat, or in some way endangering themselves. Make sure small children hold on. When your ride is operating, keep your eye on the ride and the passengers riding. Never jump on or off the ride while it is in motion.

WARNING: If a passenger tries to get out of the car while the ride is running, stop the ride until they sit down. Remember, children are unpredictable. At any time they may try to get out of their seats, regardless if the ride is moving or not.

WARNING: If there is an extremely large person sitting next to a child, you may have to reposition the passengers or let the child or extremely large person off of the ride until the next load.

WARNING: If there is any question about how securely the passenger is held into the ride, do not operate the ride until the situation is remedied.

WARNING: NEVER leave control station unattended while ride is operating.

WARNING: Remember that in an emergency, it is almost always best to turn off the ride as quickly as possible. Do not try to remove a passenger from a moving ride. Turn the ride off first, then take action.

9. **STOPPING RIDE**

Release the "Ride Start" button after the train has passed the last Kicker Wheel. Push and hold the spring loaded "Brake" switch to stop the train in the unloading area.

10. Open exit gate.

11. Using the air quick connect mounted on the front car release the handlebar locks.

WARNING: Remove air quick connect before operating ride.

12. If a lap bar does not unlock, use the manual release lever to unlock the lap bar.

13. Have passengers exit the ride area. Assist any passengers that are having a problem exiting their seat.
12. Close exit gate.
15. Open entrance gate.
16. Reload the seats and follow instructions above.

WARNING:

If any abnormal noises or movement of passengers occurs, stop the ride until the cause is remedied.

~~If~~ passengers try to stand. Stop the ride.

If passengers try to trade places. Stop the ride.

If passengers turn sideways in the seat. Stop the ride.

To prevent passengers from tampering with the control while you are loading or unloading, turn the "Key Switch" off and remove the key.

POST SET UP INSPECTION

1. When the track is set up, all the joints should fit tight with an equal amount of gap above and below the joint. Raise or lower jackstands to adjust the gap.
2. All track pins and wedges must be checked for tightness.
3. Check all wedges are "R" clipped.
4. Check all track brace pins are installed and "R" clipped.
5. Check car coupler mounting bolts for tightness.
6. Grease hitches one shot each.
7. Check wheels for proper adjustment so that they do not bind on the curves. (ADJUST WHEELS ON CURVES ONLY.)
8. Check lap bar latches for proper operation.
9. Check air compressor operation. (110 PSI max. 90 PSI min.)
10. Clear track of cords & tools.
11. Do not allow anyone in the center of the ride while the ride is running.
12. All track braces must be installed.
13. Grease wheels one shot each.
14. Check gear box grease level.
15. Check all electrical connections for security.
16. Check that all electric cords are run so that they will not be a trip hazard.
17. Check car underneath wheel axle bolts are tight.
18. Check adjustment of front car ball hitch for the front axle.

19. Check car coupler rear swivel jam nut is installed.
20. Check that all drive tires turn the correct direction.
21. Check brake for proper operation.
22. Check stairs for no more than 8" from ground to first tread.
23. Check stairs for stable positioning.

CARNYTOWN.COM

WARNING BEFORE STARTING RIDE

1. Do not allow passengers to run on platform at any time.
2. Do not allow passengers to throw items while loading, operation of ride, or unloading ride.
3. Do not allow anyone to stand up in seats at any time.
4. Place larger passengers to outside of seat. (Right side of seat.)
5. Instruct all passengers to keep arms and hands inside the seat while ride is in motion.
6. Never play tag or attempt to touch passengers while ride is in motion.
7. Never open entrance gate while ride is turning.
8. Never leave ride unattended.
9. Always look at the ride while running.

PORTABLE ADULT COASTER DAILY CHECK LIST

1. Check for loose or missing pins, wedges, & "R" clips.
2. Check lap bars for proper operation.
3. Check track jackstand adjustment screws for looseness.
4. Check track joint spreaders for cracks where they are welded to the pipe track.
5. Check car wheels for loose axle bolts.
6. Check car wheels for excessive wear.
7. Lubrication schedule has been completed.
8. Check car frames for cracks.
9. Check drive tires & brake tire for proper air pressure. (35 PSI)
10. Check drive tires for excessive wear.
11. Check brake for proper operation.
12. Check that the drive tires do not slip when operating ride.
13. Check car couplers for loose mounting bolts.
14. Check car couplers for cracks.
15. Check fiberglass body attachment bolts for looseness or missing bolts.
16. Check seat grab bars for looseness.
17. Check ride brake frame for cracks.
18. Check main motor and kicker motor frame for cracks.
19. Check main motor and kicker motor V-belts for tightness & wear.

20. Check gear boxes for leaks.
21. Check that train starts smoothly and accelerates to full speed before contacting Up Ramp kicker motor.
22. Check gear box oil level if leaks are showing.
23. Check lap bar mounting for security.
24. Check seat liner for security.
25. Check all upper scenery braces are installed & "R" clipped.
26. Check stairs for cracks.
27. Check stairs for level tread.
28. Check stairs for secure adjustment.
29. Check stairs for no more than 8" from ground to first step.

PORTABLE ADULT COASTER EMERGENCY PROCEDURES

PROBLEM:

ACTION:

Unusual noises.

Stop ride (release start button).
Push brake switch.

Ride will not stop.

Release start button.
Push brake switch.

If electric motors do not stop.

Turn off key.
Turn off main electrical-disconnect
at rear of control stand.
Ride will coast to stop.

Procedure explained.

Let go off start button:
Push brake switch.
Large red palm button:
Turn off key:
Turn off main electrical
disconnect:

This will turn off drive motors.
Activates the brake.
Cuts off power to drive motor contactor coil.
Cuts off power to drive motor contactor coil.
Shuts off power to ride.

LAP BAR INSPECTION PROCEDURE

1. Raise lap bar.
2. Check lap bar hinge bolts and lock mechanism hinge bolts for looseness or broken bolts.
3. Check lap bar air cylinder attachment pins for security and cotter pins.
4. Check lap bar arm for cracks.
5. Check that the lap bar foam is centered and in good shape.
6. Lift lap bar manual release.
7. Push down lap bar. Lap bar must ratchet down and lock at each detent.
8. Activate air unlocking system. **NOTE:** All bars should raise.
9. Turn off air unlocking system.
10. Watch as the air is released that the seat manual release lever does not stick or operate in a jerky manner.
11. Check that air cylinder mechanism releases so that bar will lock.
12. Push down lap bar. Lap bar must ratchet down and lock at each detent.
13. Repeat for each seat.

LAP BAR LUBRICATION

Weekly

Oil all hinge bolts.

Oil lock gear pivot bolts.

Oil air unlocking cylinder pivot pins.

Grease gear teeth.

DRIVE MOTOR PIVOT BEARING

GREASE ONCE A MONTH TYP. 2

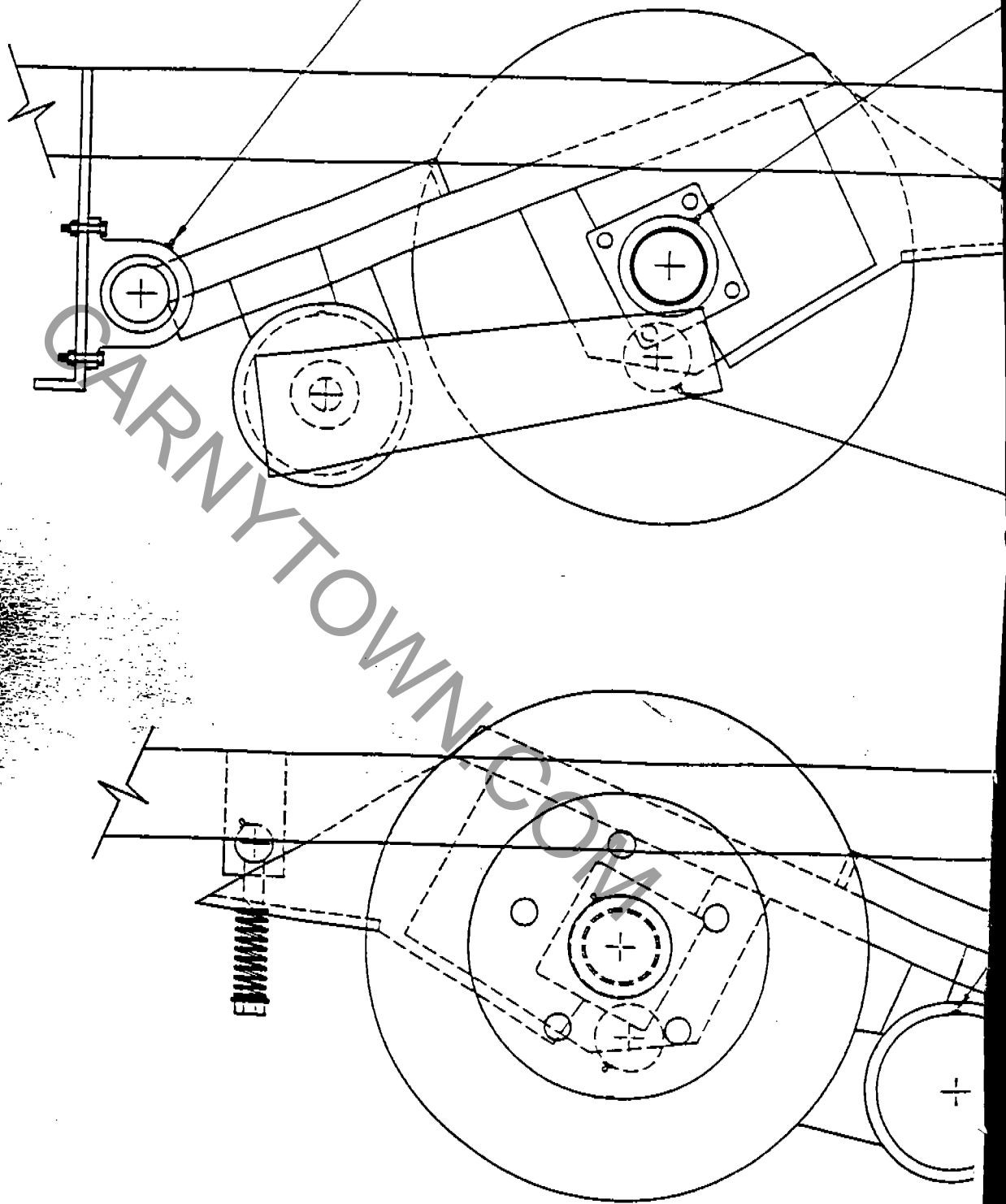

GS

GEAR BOX SUPPORT BEARINGS

GREASE ONCE A MONTH TYP. 2

DRIVE MOTOR SPRING CUSHION BUSHING

GREASE DAILY TYP. 2

GEAR BOX OIL

CHANGE OIL IN GEAR BOX ONCE A YEAR

DRIVE MOTOR BEARINGS

GREASE YEARLY TYP. 2

CONFIDENTIAL INFORMATION

The information and data contained herein is proprietary and is submitted in confidence, and shall not be disclosed, used or duplicated for any purpose whatsoever without the prior written permission of Forsythe & Lewis Rides, Inc., dba WMI Industries, P.O. Box 5000, Sterling, Colorado 80751. This legend shall be marked on any reproductions hereof in whole or in part. Receipt of this document shall be deemed to be an acceptance of the conditions specified herein.

MAY 23 1994

DANGER:

TURN OFF AND LOCK OUT MAIN ELECTRICAL DISCONNECT BEFORE SERVICING LUBRICATION ZERKS



WISDOM INDUSTRIES

Merino, CO 80741

SCALE: 3" = 1'-0"

APPROVED BY:

DRAWN BY: JLC

DATE: 5-23-94

REVISED

DESCRIPTION

KICKER MOTOR (LUBRICATION)

EQUIPMENT:

MINER MIKE

DRAWING NUMBER

KICKER

19a

WHEELS

GREASE ONCE A WEEK TYP. 48
(6 EACH CAR)
(8 ON FRONT AXLE ONLY)

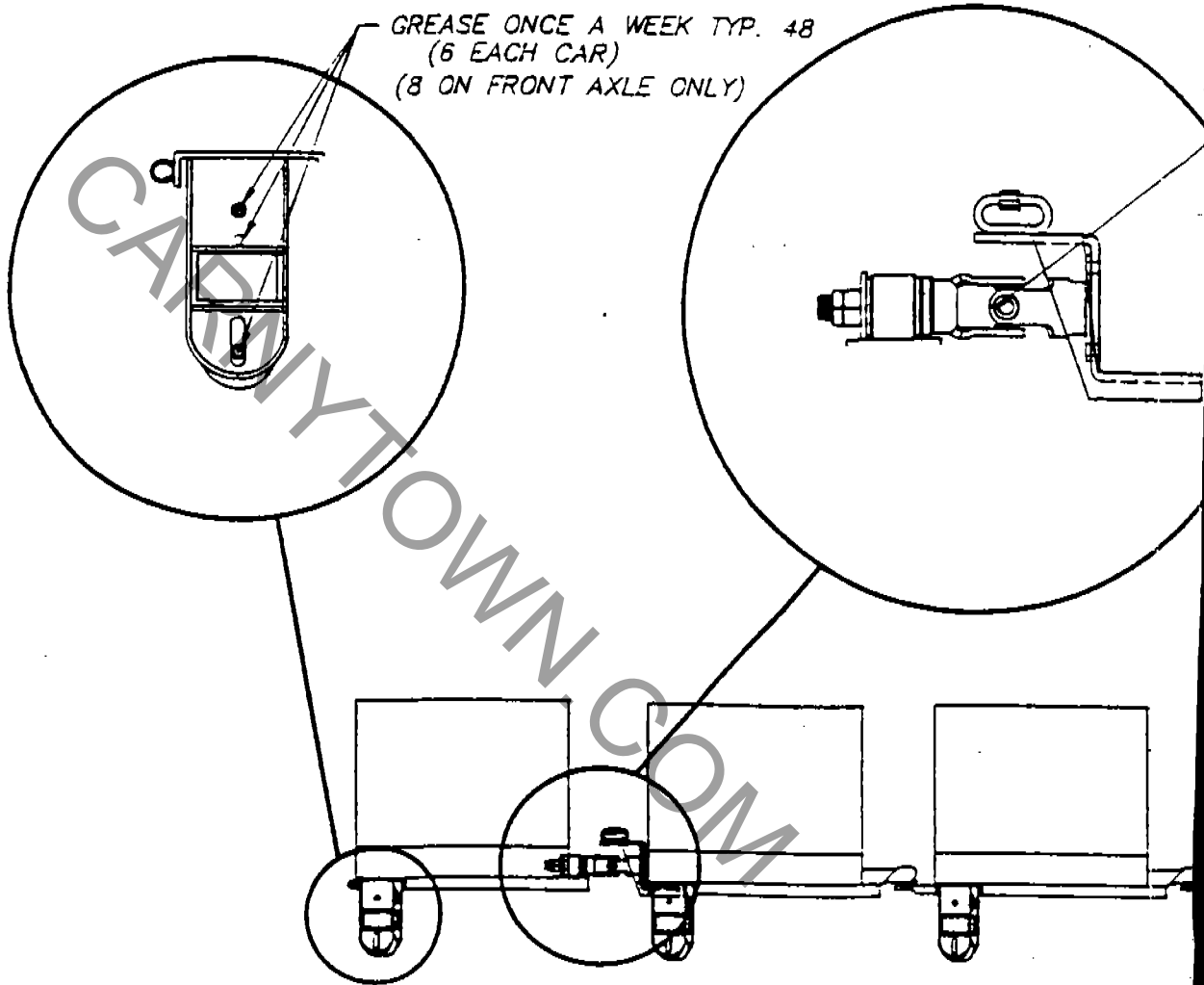

CARNYTOWN.COM