

WEBBER

Engineering & Manufacturing Inc.
909-889-0039

MFG: WEBBER ENG. & MFG. CO.
INC.
NAME: BUMPER BOATS
TYPE: NON-KIDDIE

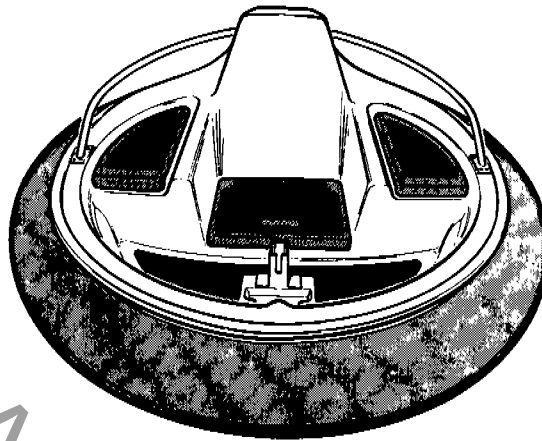

THE BIG SPLASH

MAKE A BIG SPLASH WITH OUR BUMPER BOAT AND SPLASH YOUR WAY INTO BIG BUCKS. Our body is available in a variety of bright colors such as red, blue, green, yellow, purple, orange and white. It is a strong, safe body, comfortable for all ages and supported by very colorful red, blue, green or yellow vinyl tubes. The BIG SPLASH is equipped with stainless steel handrails and propeller guards. A 360 degree rotating engine gives quick maneuverability and easy handling, and the variable speed throttle is so easy anyone can operate it. The 2 gallon fuel tank usually provides 8 hours of entertainment before a refill. Our tank is available in 5 colors: red, blue, yellow and natural. Our specially modified 2 HP Honda 4 stroke motor is probably the most maintenance-free motor for the concession industry today. **THE ONLY BUMPER BOAT ON THE MARKET WITH ACCESS TO BODY THROUGH REMOVABLE SEAT, MAKING MAINTENANCE A SNAP.**

It's a good rule to plan at least 350 square feet per boat or for ten boats an area of 50' x 75' with the depth of 28" minimum and a maximum depth of 36".

Concrete, asphalt or hypolon liners are suitable surfaces for bumper boat pools. This low maintenance, inexpensive operation, and fun for all ages ride, is a super addition to any park or just on its own.

- **Suzuki 2 Stroke Motor available upon request**
- **Steering Handles, Stainless Steel Propeller Guards are standard**

Honda 2hp

- Quiet, 4-stroke technology.
- No smokey 2-stroke exhaust.
- No oily film left on water.
- Unsurpassed fuel economy.
- Lightweight 2hp single cylinder engine.
- Oil level inspection window.
- Maintenance free electronic ignition.
- 360 degree steering ease.
- Ideal for small sailboats and canoes..

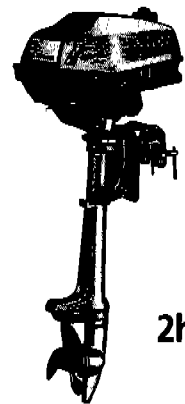

2hp

WEBBER
Engineering & Manufacturing Inc.
909-889-0039

THINGS TO KNOW WHEN BUILDING A BUMPER BOAT OPERATION

1.  Indicates low level lights around pond. (40 Watts); generally all amber colored.
2. Over dock should be high light — possibly 150 Watt Sodium Vapor or 400 Watt Mercury Vapor.
3. The pond must have a high level over-flow.
4. Sprinkler system should be on islands.
5. Install compressor in filter room.
6. A gas storage tank will be required.
7. Honda 4 stroke engine uses straight regular or unleaded gasoline. Suzuki 2 stroke engine requires a 50 to 1 gas/oil mixture.
8. Oil may be mixed in portable gas tank.
9. All skimmers should be on the side of the pond toward which the prevailing winds blow.
10. The discharge lines should be opposite the skimmers.
11. The filtration system should be the minimum required by the Building Department. **No one should swim in the pond.**
12. Docks may be wood supported over the water.
13. One single dock could replace the two shown.
14. Pond should be totally fenced to keep children out of the water.
15. 50% of pump suction should come from skimmers; 50% from bottom drain with valves to control each.
16. Bottom drain to be in a dished-out low spot.
17. Trees should be away from pool to minimize leaves in filters.
18. Pool depth should be a minimum 28" and maximum 36".
19. Hypolon rubber liner (45 mil-nylon reinforced black) can be used to line the bottoms of pools in place of concrete or asphalt.

WEBBER

Engineering & Manufacturing Inc.
909-889-0039

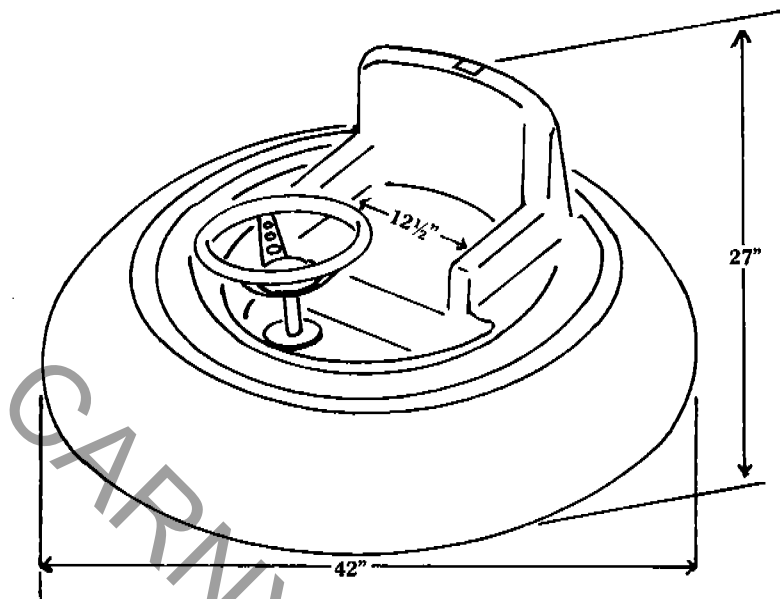

Introducing . . . "THE LITTLE SPLASH"

This light-weight, battery powered, child's bumper boat will be a real heavy-weight when it comes to bringing in the money and crowds. It can be used in a permanent or portable pond approximately 26' x 35' in size, and 12" to 14" deep. It is a low maintenance, mobile **MONEY MAKER**. You can't afford to let this one be the "ONE" that got away.

"THE LITTLE SPLASH" is available in red, blue, green and yellow plastic bodies. Tubes are roto molded, made from tear and puncture resistant virgin vinyl, available in red, blue, green and yellow. Available with optional on and off switch or timer.

- BODY:** 3/16" Hi-density polyethylene with ultra-violet inhibitors
Colors: red, blue, yellow and green
Removable stainless steel metal band holds top and bottom in place, top can be easily removed for maintenance
Urethane foam seat 10" deep x 12 1/2" wide
- MOTOR:** Electric 2 speed - 12 volt electric, 20 lb. thrust
Amps draw: speed #1, 8 amps w/4.5 lbs. of thrust
 speed #2, 15 amps w/10 lbs. of thrust
Motor weight approx. 8 3/4 pounds
Durable aluminum propeller with shear pin and stainless steel prop guard
Propeller and motor skag extends 5 1/2" below tube
- GENERAL:** All dimensions above approximate and in inches
3 to 5 M.P.H. maximum (approximate)
Net weight 45 lbs. (approximate)
100 pounds maximum passenger load capacity
Battery: 12 volt deep cycle, 80 amp-hour, group size #24

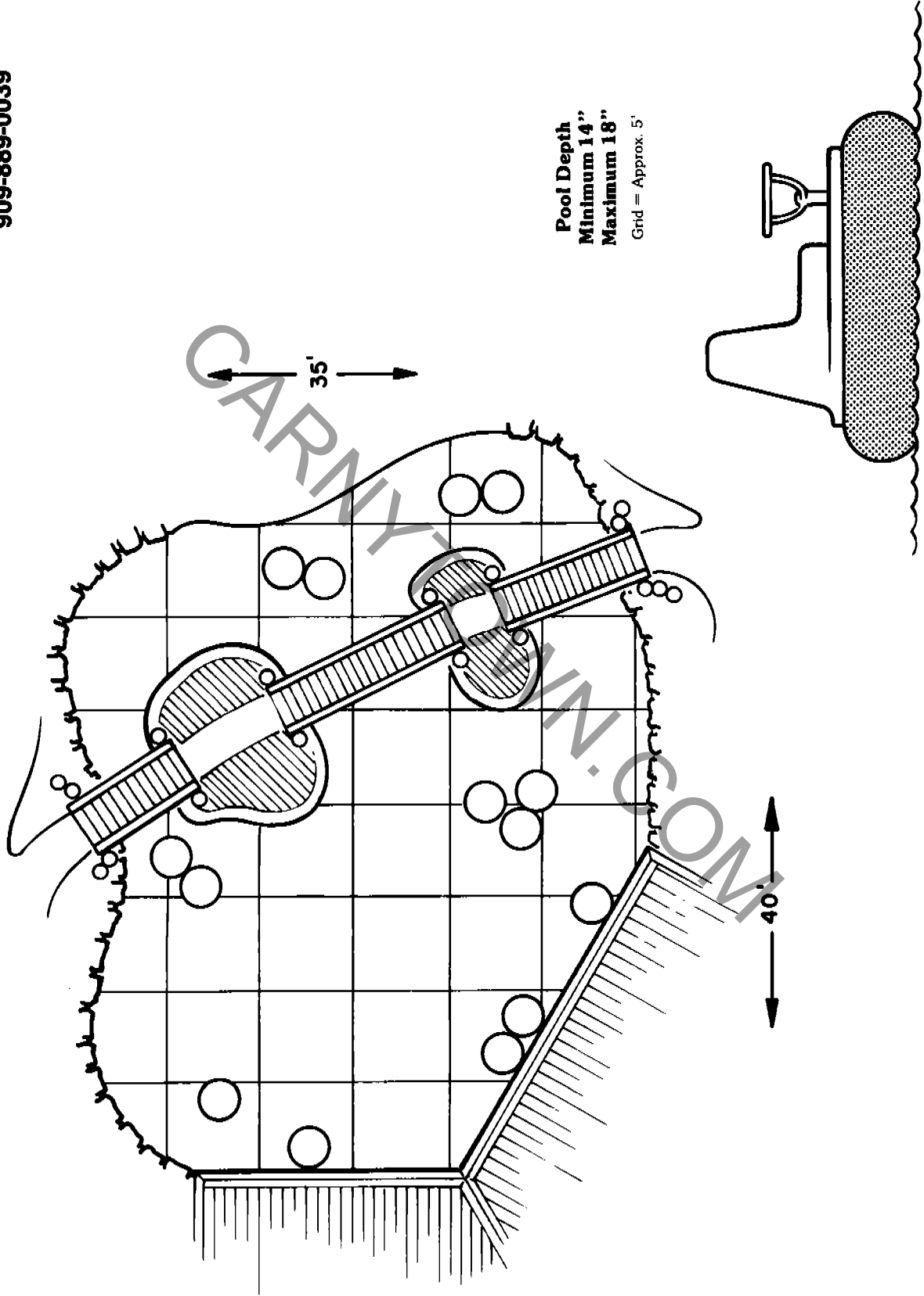

WEBBER
Engineering & Manufacturing Inc.
909-889-0039

**RAPIDS RIDE TUBE and
SHALLOW POOL FLOTATION TUBE**

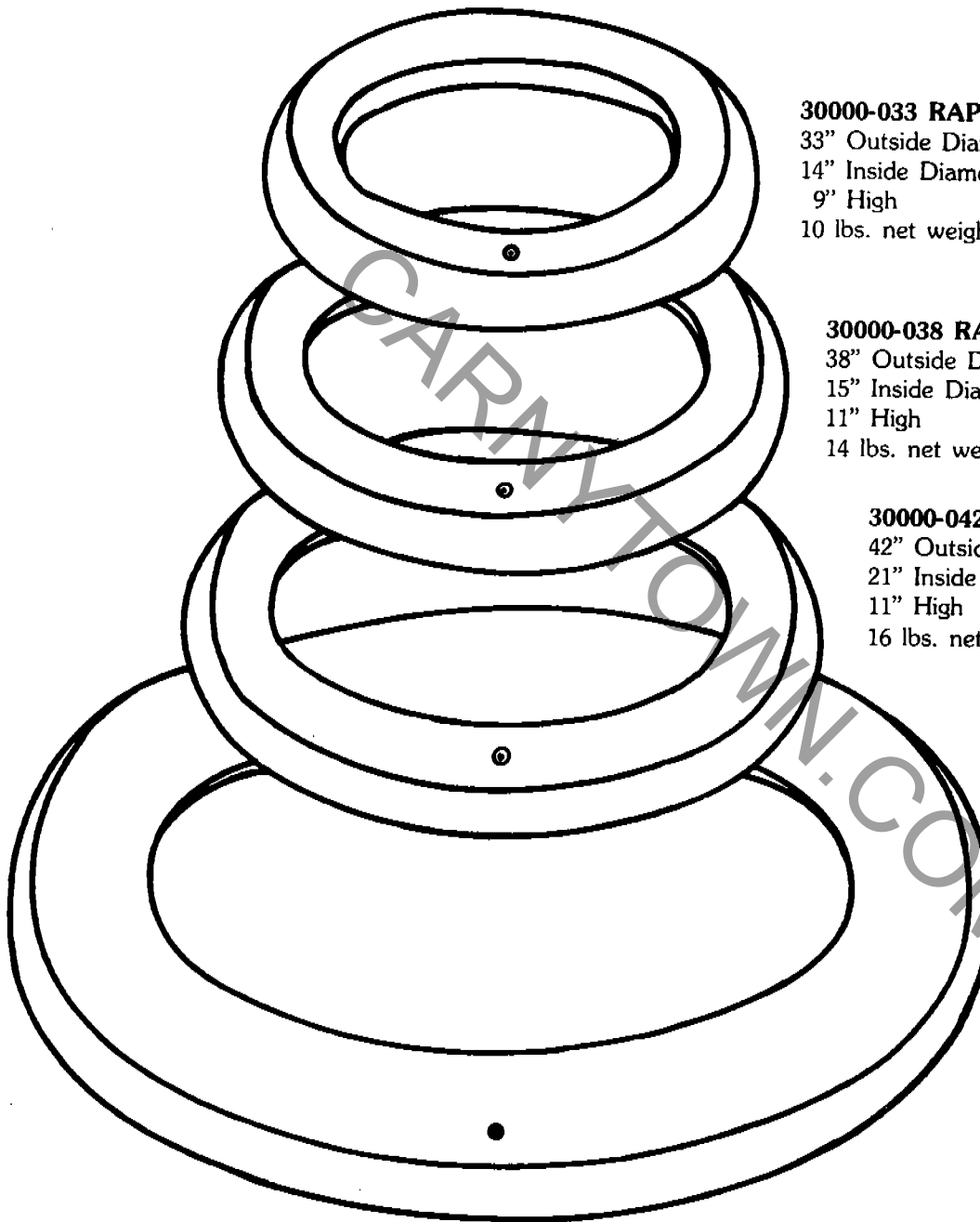

30000-033 RAPIDS RIDE TUBE

33" Outside Diameter x
14" Inside Diameter x
9" High
10 lbs. net weight

30000-038 RAPIDS RIDE TUBE

38" Outside Diameter x
15" Inside Diameter x
11" High
14 lbs. net weight

30000-042 RAPIDS RIDE TUBE

42" Outside Diameter x
21" Inside Diameter x
11" High
16 lbs. net weight

**30000-065 SHALLOW POOL
FLOTATION TUBE**

65" Outside Diameter x
38" Inside Diameter x
13.5" High
30 lbs. net weight

**THE ONE AND ONLY
VINYL TUBE FOR
YOUR WATER RIDES**

- * Made only with Virgin Vinyl, absolutely no fillers
- * 125 MIL thick
- * Long life — Low maintenance
- * No Ozone deterioration causing discoloration to flume or rider's clothing
- * No protruding valve stem
- * Available in Red, Blue, Green and Yellow

CARNYTOWN.COM

WEBBER

Engineering & Manufacturing Inc.

909-889-0039

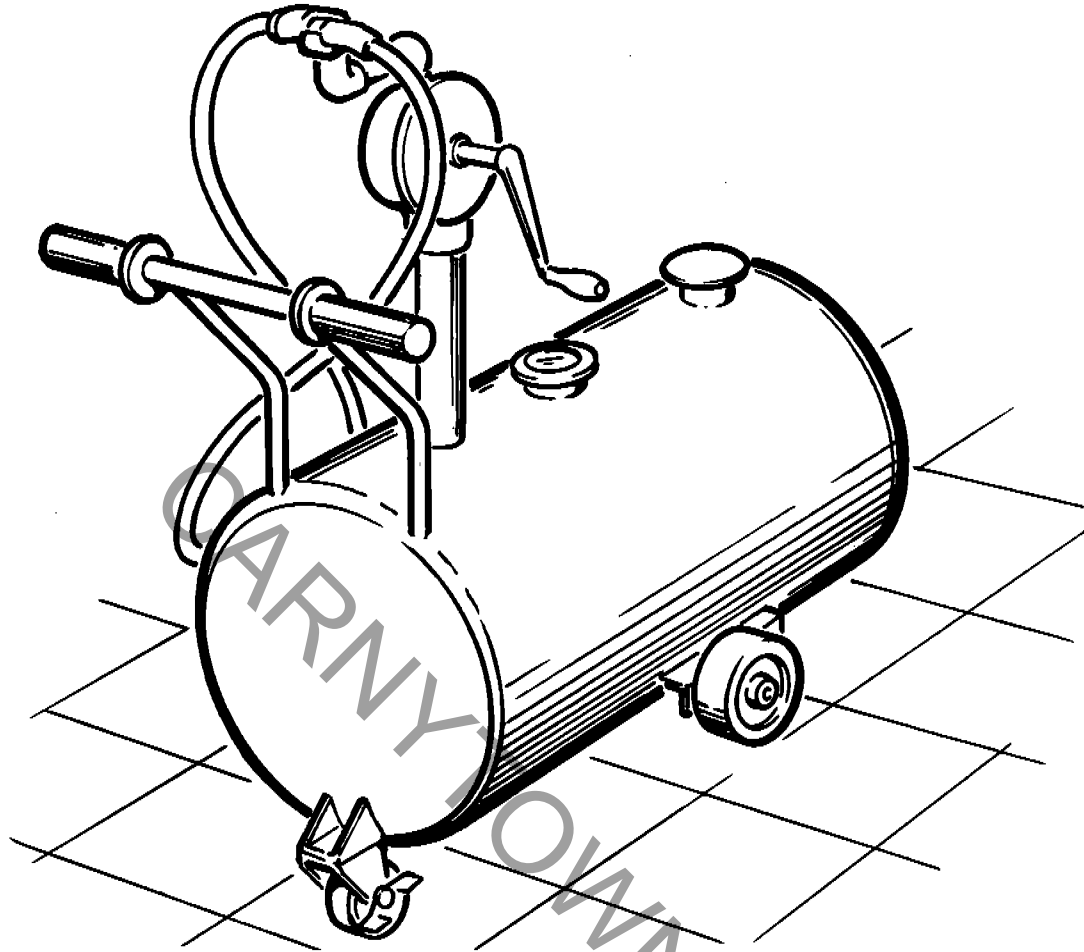

GASOLINE DISPENSING CART

EXCELLENT MOBILITY
GASBOY ROTARY PUMP - 12 GALLONS PER MINUTE
40 OR 60 GALLON CAPACITY
10 GAUGE STEEL TANK
AUTOMATIC SHUT - OFF NOZZLE
ABC RATED FIRE EXTINGUISHER
TANK LEVEL GAUGE
GAS FILTER ON DISCHARGE LINE
BRAKE ON REAR SWIVEL WHEEL

WEBBER Engineering & Manufacturing Inc.
Phone (909) 889-0039 • FAX: (909) 889-1434

GDC-1

CARNYTOWN.COM

WEBBER

Engineering & Manufacturing Inc.

909-889-0039

WEBBER RACER TRACK SPECIFICATIONS

TRACK. Concrete or asphalt can be used as your track surface. Make sure it is a good grade of asphalt to insure smooth, surface finish (such as tennis court mix). Asphalt should be a minimum 2" thick. If concrete is used, the finish should be smooth, but not glossy. Surface finish is important because if surface is too rough, tires will wear excessively; if surface is too smooth, a little moisture could make cars uncontrollable. Note, all joints should be interlocked together to prevent misalignment of joints.

STRAIGHT-AWAY LENGTH. Should be 150 feet maximum. Longer lengths tend to be boring.

TRACK WIDTH. Should be a minimum of 20' between rails. We recommend that track be 5' wider on turns than on straight-aways.

BANKING on turns will help reduce tire wear. Maximum banking is one inch per foot of track width. Straight-aways must be flat except for two degrees allowed for drainage.

FIGURE-8 TRACKS. Tunnel should be approximately 70" high. Overpass should have long, gentle-sloping ramps approximately 40' on each side. Length of track should be 600' minimum. By using doors or chain link fence, the tunnel can be incorporated as secured car storage at night.

TRACK GRADE recommended, five percent maximum.

SAFETY APRON should exist around "open track", such as a good grade of turf. Where 180 degree turns exist, a barrier 18" high should be installed. No confining barriers should be used with an "open track".

GUARD RAILS. When cars are used **without** steel body bands, guard rails should be 14" high min. to 16" high max. 2" thick x 3 feet to 8 feet long knot free planks faced with conveyor belt or stainless steel sheet and hinged at each joint can be used. Rails should be 2" above track surface backed up by tires of equal diameter with every other tire two tires high. Tires should be anchored with 1" dia. rebar or round bar.

When cars are used **with** steel body band, a rail 1/2" to 5/8" thick x 6" high with a 36 hot rolled steel bar backed up with equal dia. tires and anchored with 1" dia. rebar or round bar should be used. Rail and tires should be two inches above track surface.

LOADING ZONE should have separate entrance and exit lanes. A marked deceleration lane will improve the safety and operation of your track.

SIGNAL LIGHTS. Use a minimum of two and maximum of four for traffic control - starting, stopping, caution - controlled by your operator or automatic timing device.

FENCING height should be 4' minimum. Posts should be 10' on center. We recommend that fencing be on the inside of posts. Try to use chain link or two inch solid board or cement block as long as cars are not in direct contact. Gates should be supervised by an attendant when track is open and locked when track is closed.

SPECTATOR AREA should be separate from track and pits by a fence. Bleachers or grandstands should be constructed with back and side rails.

PARKING AREAS must be level, graded and free from obstructions or obstacles with adequate handicap parking and access.

WIRING should be installed in compliance with the requirements of the National Electrical Code.

FIRE EXTINGUISHERS should be installed in sufficient quantity to provide adequate protection.

MAXIMUM SPEED recommended, 18 M.P.H. A well designed, exciting track, doesn't need for the racers to go any faster.

HEIGHT REQUIREMENT of 54" minimum.

TRACK SKETCHES included in this literature package are meant as guidelines only. Adjustments will have to be made to suit your needs.

SAFETY SIGNS should be displayed prominently at various locations.

RULES should be verbally instructed to each group of riders after boarding cars and displayed prominently where riders may read them without difficulty.

WEBBER
Engineering & Manufacturing Inc.
909-889-0039

