

Exsaco Corporation

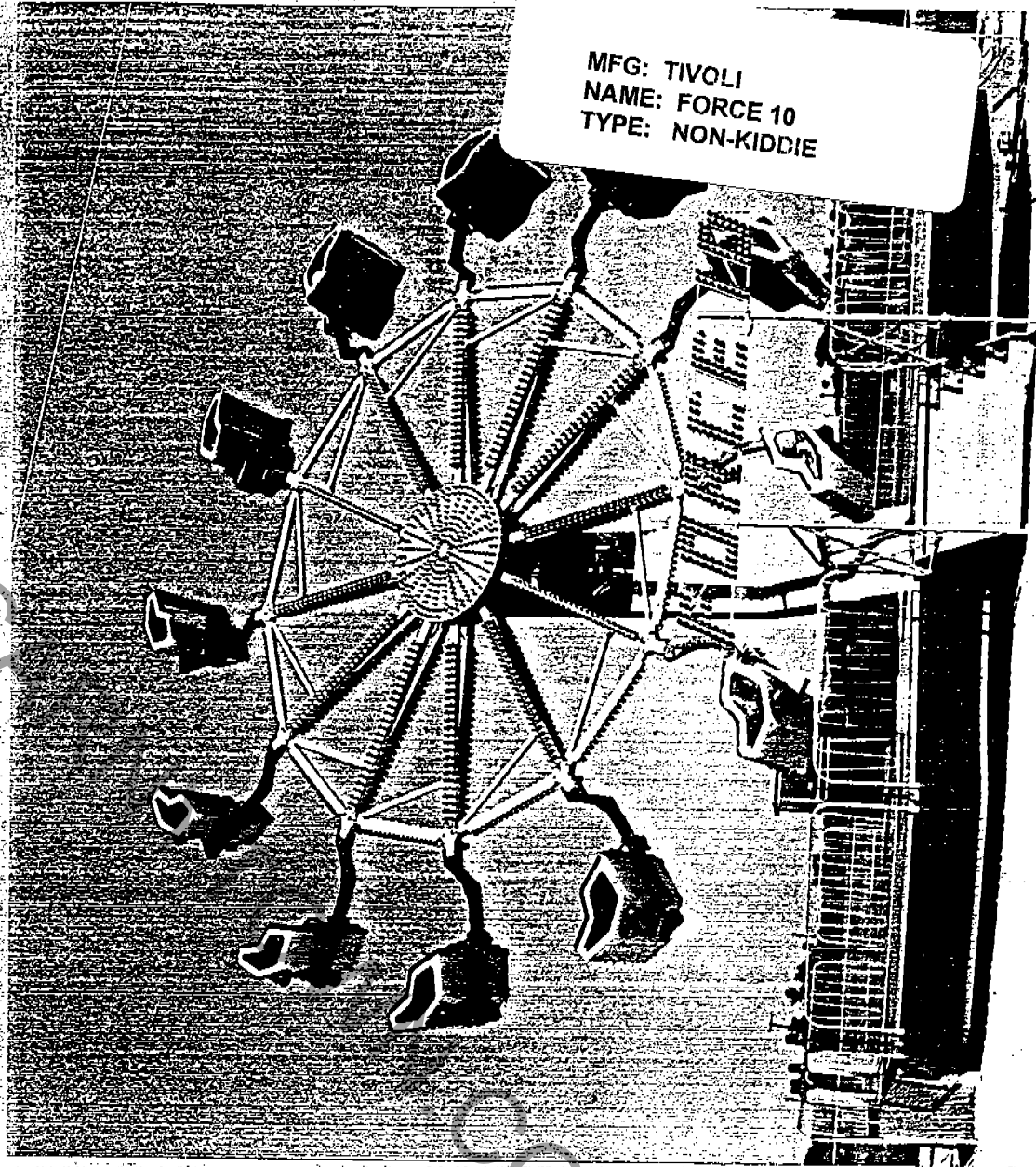

Look To Exsaco for
New and Innovative Rides
"The Reliable Source"

P.O. Drawer 328
One North Santa Fe
Amarillo, Texas 79009
(817) 789-2265 / Tlx 730300

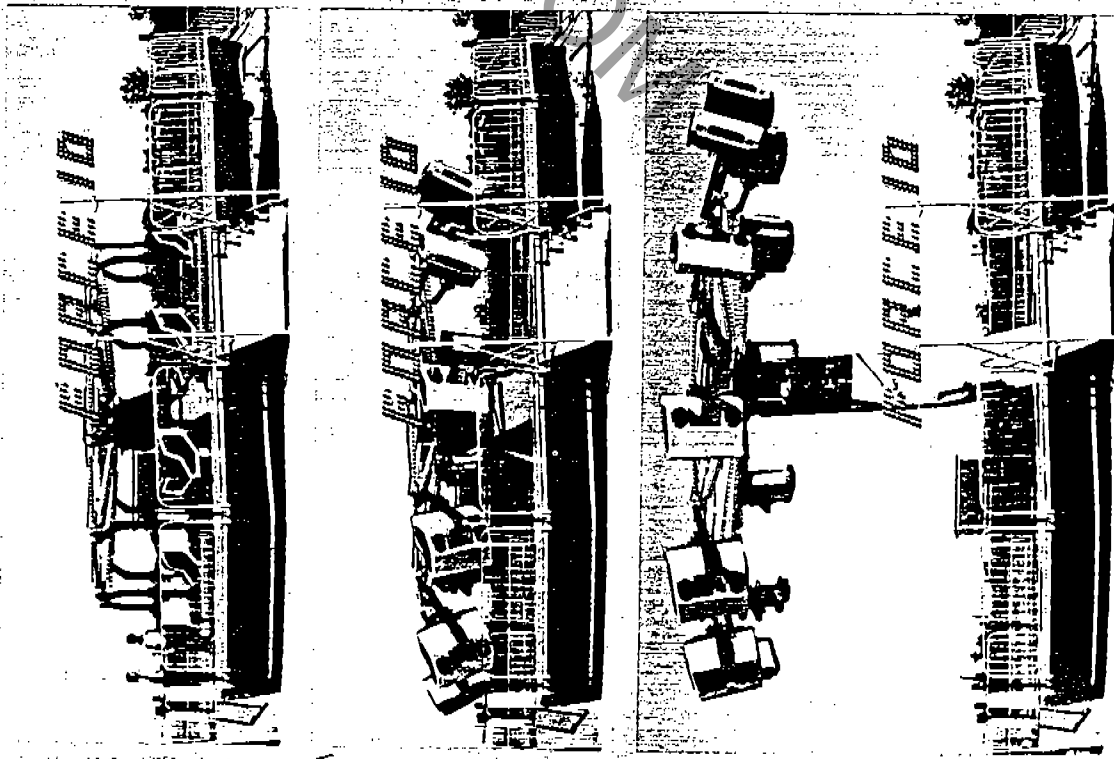

MFG: TIVOLI
NAME: FORCE 10
TYPE: NON-KIDDIE

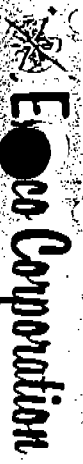

FORCE 10 SPECIFICATIONS

SEATING

Number of Cars 12
 Maximum Number of Passengers per Car 3
 Maximum Total Number of Passengers 36
 Loading All Cars Simultaneously
 Capacity 800 per HOUR

PERFORMANCE

Direction of Travel Clockwise
 Ride Speed 24 rpm
 Swing 90°
 Motion Through 3 Different Planes
 Operation Automatic

MOTOR & DRIVE

Motor Type 220 Volt 3 phase 60 HZ
 Horse power 75
 Drive Hydraulic
 Control Electric Relay

LIGHTING

Sweeps & Scenery 1700 Turbodiesels
 Vehicles 12 Volt Head & Tail Lights

POWER REQUIREMENTS

Total 75 KW
 Motor 65 KW
 Lights 10 KW
 Minimum/Maximum line Voltage 208/230

SET-UP

Time 3 Men, 2 hrs. -1 trailer
 Power Requirements 220V/3P
 12V for set-up

TRAILER

Height 13 ft. 6 in.
 Width 8 ft.
 Length 48 ft.
 Total Weight 67,500 lb.
 Real Axle Weight (13 Axles) 43,300 lb.
 Kingpin Weight 24,200 lb.
 Tire Size 8.25x15

OPERATING DIMENSIONS

Width 46'6"
 Depth 59'
 Height 45'

These specifications subject to change without notice.

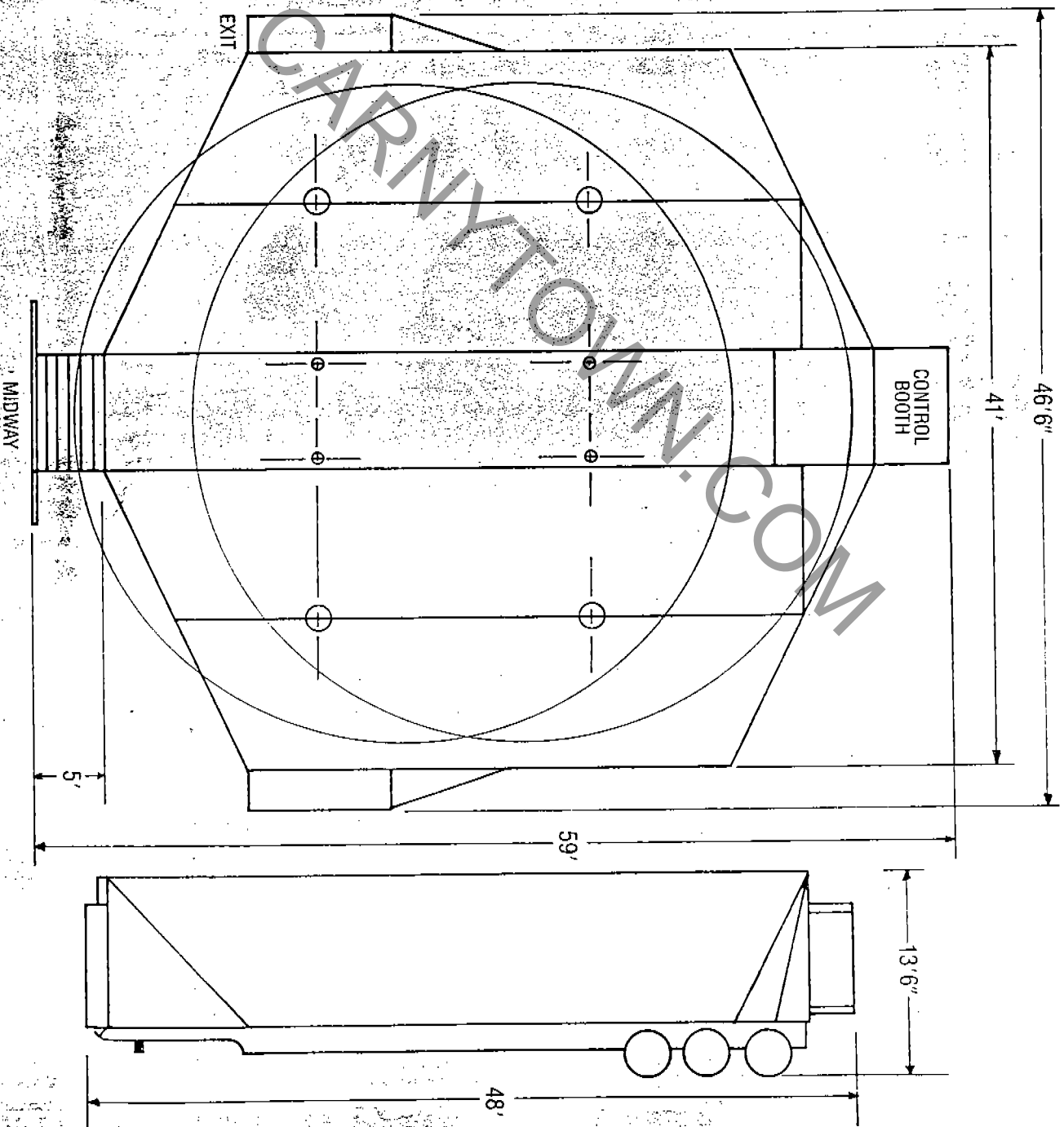

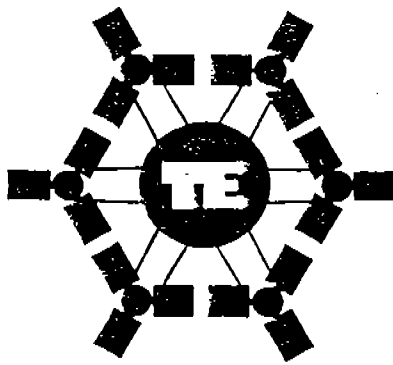

Tivoli Enterprises Ltd

Howfield Lane, Chartham, Canterbury, Kent CT4 7HG England.
Telephone: 0227 731156

FORCE 10 OPERATION DESCRIPTION

The Force 10 is hydraulically driven, electrically controlled. Its motions are caused by a series of control relays that either blocks or allows a certain action to occur, in sequence. The ride operates as follows: Upon pressing of the slow speed button the ride will start to rotate (approximately 3 rpm). This is used to check whether all patrons are seated and lap bars are locked. When the fast speed button is pressed the ride goes into an automatic cycle for the duration of the pre set timer (adjustable by the operator). The ride will start a faster rotation slowly increasing speed until it has reached 24 rpm. After approximately 20 seconds (factory set timer), the ride will automatically lift. The ride will lift until the boom approximately 75° up. During its lift process, it will pass a proximity switch located at approximately 30°. This is a safety control which will not allow further travel unless all systems are functioning in their correct order. When the boom reaches the top of its travel, the tilt cylinder will activate tilting the center hub until it is parallel with the ground. After a pre-set time (factory set), the hub will tilt back down. Depending on the duration of pre-set timer, the ride will either tilt upward again (after a preset time) or the boom will proceed to lower. After passing the 30° point, the ride will automatically slow and go into a hydraulic brake mode. When the boom is completely down and turning slower than 3 rpm, the disc brake can be activated. At that point, bring ride to a stop.

FORCE 10 OPERATING PROCEDURES

RIDE CONTROLS

The Force 10 is an amusement ride which is controlled via a control console located in the control booth. The following controls are located on this panel.

- A. Pump Start and Stop Buttons - These buttons control the main hydraulic pump electric motor. It is only necessary to start the pump at the beginning of the operating day. The pump should be left on until the ride is closed.

- B. Jacks Pump Start/Stop - This is used for starting pump motor for jacks, used for set-up and tear down.
- C. Control Key Switch - This key activated control panel.
- D. Ride Timer - This timer should be adjusted so that one complete ride cycle is made up of the following: the boom raises, tilts up, tilts down, and boom immediately lowers. This duration is approximately sixty (60) seconds.
- E. Slow Speed Button - When the green light is on, ride will operate in slow speed only by pressing button.
- F. Fast Speed Button and Indicator Light - When the green light is illuminated, the fast speed button can be depressed starting the automatic cycle.
- G. Brake Button - The button activates the disc brake to allow the ride to slow to a stop more quickly (during high traffic times) than normal hydraulic braking. The brake button should be pressed only when rotation is less than three (3) rpm.
- H. Light Switch - Turns on all lights on ride.
- I. Car Light Switch - Turns on all lights on cars.
- J. Emergency Stop - This button, when pressed, brings the ride the quickest level stop. If the ride is raised over 30°, the hub and sweeps will automatically level parallel with the ground and come to a complete stop. After the emergency situation is investigated, ride can be brought down through the emergency reset.
- K. Emergency Reset - When emergency system is used, this button will reset system to allow ride to be lowered.
- L. Reset Key Switch - The key switch operated by control key) will allow ride to be lowered by first pressing reset button then turning key.
- M. Power On Indicator - This light indicates that the main power switch is on and there is current to the control panel.
- N. Overload Indicator - This switch indicates an overload in the motor circuit. When light is on, motors will not operate until overload relays are reset. Before resetting and restarting pump motor, investigate the source of the problem.

NUMBER OF PERSONNEL

The Force 10 Amusement Ride requires a minimum of two (2) persons to safely operate the ride. One (1) person should be located in the control booth at the controls in constant visual contact of the ride. The second person should be stationed at the bottom of the entrance steps in full view of the ride, entrance, and exit ramps. **Operators are not allowed on the platform when the ride is operating!**

PASSENGER RESTRICTIONS

Signs should be posted near the ride in easy visual range of all riding passengers that indicates the following:

1. No food or drink allowed on ride
2. Three (3) passengers per seat
3. No running on platform
4. Remove any loose articles before riding
5. The ride operates with forces in excess of 3 g's. Persons with a history of heart problems, back problems should not ride.
6. No pregnant women allowed
7. No riders under the age of seven (7) years of age unless accompanied by an adult.
8. No riders under 48" in height.

OPERATION OF RIDE

During one (1) complete ride cycle, the following procedures should be followed:

1. Allow passengers to enter ride up to 36 passengers, three (3) per seat.
2. Check all seats after loading to assure lap bars are properly locked.
3. Close all gates and chains. **NO PERSONS ALLOWED ANYWHERE ON PLATFORM DURING OPERATION OF RIDE.**
4. Check ride timer. Timer should be set for no longer than 1.5 minutes.
5. Start ride in slow speed. First allow ride to rotate at least one (1) full rotation. Visually check all seats to assure that all lap bars are latched.
6. Start ride cycle by pressing fast speed button.
7. Monitor ride during operation for passengers riding in unsafe manner. Stop ride if necessary.
8. At completion of ride cycle, allow ride to come to complete stop.
9. Assist passengers in exiting the ride.
10. Clear platform completely before allowing additional passengers to enter ride.

OPERATIONAL SAFETY CHECKS AND INSPECTIONS

This section deals with visual inspections and safety checks of the Force 10 Amusement Ride. They are designed to assist the operator in the control of the operation of the ride. The inspections and checks should be accomplished by a qualified technician capable of understanding the functions of the components. This equipment has been designed and built to handle normal wear and tear of every day operation. It is always necessary to inspect all components and structures on a regular basis and to note or investigate any irregular conditions. It is also necessary to consult owners manual for additional maintenance and inspection procedures. In the event of any abnormal condition that is capable of causing a future failure of any component, if found it should be reported to necessary personnel and if necessary the factory should be consulted.

A. Daily Inspections

1. Inspect all blocking and level of main frame and platforms. Repair, re-assemble, or re-level any loose blocking if necessary.
2. Check all fencing for security. Check condition of gates and chains.
3. Inspect platform for obstructions, loose floor panels, and/or tripping hazards.
4. Inspect seat lap bars and latch for proper operation.
5. Inspect all assembly pins to assure they are properly keyed.
6. Check operation of boom descent limiting pins. (Refer to Service Bulletin 00103.)
7. Inspect operation of power failure valve. (Refer to Service Bulletin 00103.)
8. Check operation of emergency stop. (Refer to Service Bulletin 00103.)
9. Check set wiring on sweeps and center. Repair any loose or hanging wires.
10. Test operation of ground faults.
11. Inspect wiring in main electrical panel.
12. Operate ride. Check for any unusual noises or actions. Investigate if necessary.
13. Report any problem or concerns to the proper personnel.
14. Check all lap bar padding.

B. Weekly or Pre-Opening Checks

1. All daily checks.
2. Check revolutions per minute (rpm). Should not exceed 24 rpm CW.
3. Check hydraulic fluid levels. Reservoir should be completely full. If below sight glass, fill immediately.
4. Check operation of disc brakes.

5. Check operations of cooling fans and oil filters. If bypass indicator on filter is red, change immediately.
6. Inspect all proximity switches for security and position.
7. Inspect incoming wiring. All connections should be tight (5 wires, 3 phase, neutral, ground).
8. Inspect all hydraulic lines for leaks.

EMERGENCY AND POWER FAILURE PROCEDURES

In the case of a power failure or an emergency situation, follow the procedures outlined in Service Bulletin Number 00103. In all cases, report any uses of emergency systems to the proper authority and never restart the equipment until the situation is thoroughly investigated. Report any use of the emergency system to the manufacturer.

PASSENGER RESTRAINT SYSTEM

Each vehicle is equipped with an over-the-shoulder lap bar. The bar locks by a spring activated drop bar which requires a handle to be pulled behind the car to release.

NON-DESTRUCTIVE TESTING AND SAFETY MODIFICATIONS
POLICY FOR TIVOLI, LTD.

All Tivoli manufactured amusement rides are designed to the highest degree of safety and quality. In depth engineering and design analysis has been incorporated into all equipment produced. Tivoli, Ltd., therefore, requires no scheduled testing by non-destructive means for the engineered life of the components, unless listed below and issued to customer in the form of a service or safety bulletin, or indicated in Operation Manual.

It should also be understood that this policy is based on the operator/owner exercising proper maintenance and care procedures of all components according to the manufacturers' specifications, along with routine visual inspection of all structural components for any unusual circumstances. Any unusual circumstance must be reported to the manufacturer immediately.

In the event that a fault or potential safety problem is discovered through our own testing or field experience requiring an annual test or modification, information concerning these tests or modifications will be made available immediately to the owner of the equipment.

Below are listed all current safety service bulletins or equipment modification bulletins.

<u>BULLETIN NUMBER</u>	<u>RIDE</u>	<u>CONCERNING</u>	<u>EFFECTIVE DATE</u>
00103	Force 10	Safety system	July 8, 1988
00000	Force 10	Boom Crack	
00108	Force 10	Lap Bar Spring	Jan 16, 1989

Tivoli Enterprises, Ltd.

NON-DESTRUCTIVE TESTING AND SAFETY MODIFICATIONS
POLICY FOR TIVOLI, LTD.

All Tivoli manufactured amusement rides are designed to the highest degree of safety and quality. In depth engineering and design analysis has been incorporated into all equipment produced. Tivoli, Ltd., therefore, requires no scheduled testing by non-destructive means for the engineered life of the components, unless listed below and issued to customer in the form of a service or safety bulletin, or indicated in Operation Manual.

It should also be understood that this policy is based on the operator/owner exercising proper maintenance and care procedures of all components according to the manufacturers' specifications, along with routine visual inspection of all structural components for any unusual circumstances. Any unusual circumstance must be reported to the manufacturer immediately.

In the event that a fault or potential safety problem is discovered through our own testing or field experience requiring an annual test or modification, information concerning these tests or modifications will be made available immediately to the owner of the equipment.

Below are listed all current safety service bulletins or equipment modification bulletins.

<u>BULLETIN NUMBER</u>	<u>RIDE</u>	<u>CONCERNING</u>	<u>EFFECTIVE DATE</u>
00103	Force 10	Safety system	July 8, 1988
00000	Force 10	Boom Crack	
00108	Force 10	Lap Bar Spring	Jan 16, 1989

Tivoli Enterprises, Ltd.

**RIDE NAME: FORCE 10
OTHER NAMES: TIP TOP**

Manufacturer:

Tivoli Enterprises Ltd.
Howfield Lane
Chartham NR, Canterbury, Kent
CT4 7HG England

U.S. Representative:

Exsaco Corporation
One North Santa Fe Street
P.O. Drawer 328
Alvarado, Texas 76009 USA

Date of Inception and Completion of First Unit: 1980
Number of Rides Operating in USA: 7
Number of Rides Operating Worldwide: 11

OPERATING SPECIFICATIONS
DIMENSIONS (APPROXIMATELY)

Static: (No Clearance)		Dynamic:	
Height	13'6"	Height	45'
Width	46'6"	Width	46'6"
Depth	59'0"	Depth	59'0"

Total Weight Static: 68,000 Pounds Approximately
Ride Speed: 24 RPM Center
Passenger Capacity: 36 Adults
Number of Vehicles: 12 - 3 passengers per tub
Estimated Capacity/Hour: 900

OPERATING RESTRICTIONS

Passenger Height Restriction: 48"
Passenger Age Restriction Unless Accompanied by Adult: 7 Years
Recommended Ride Duration: 1.0 Minute
Passenger Load Balancing Requirements: Yes
Maximum Wind Speed for Operation: N/A
Maximum/Minimum Temperature for Operation: Minimum 32° F

ELECTRICAL REQUIREMENTS

Voltage: 230 maximum 208 minimum
Type: 3 phase, 60 cycle, N.Grnd.
Maximum Power: 85 kw 275 amps
Maximum Lighting Power: 15 kw 45 amps

TRAILER INFORMATION

Trailer Length: 48 ft. 0 in.
Height: 13 ft. 6 in.
Width: 8 ft. 6 in.

Total Weight (Approximately): 24,200 lbs. (approximately)
43,300 lbs. (approximately) rear 3 axles

DYNAMIC AND STATIC LOADS

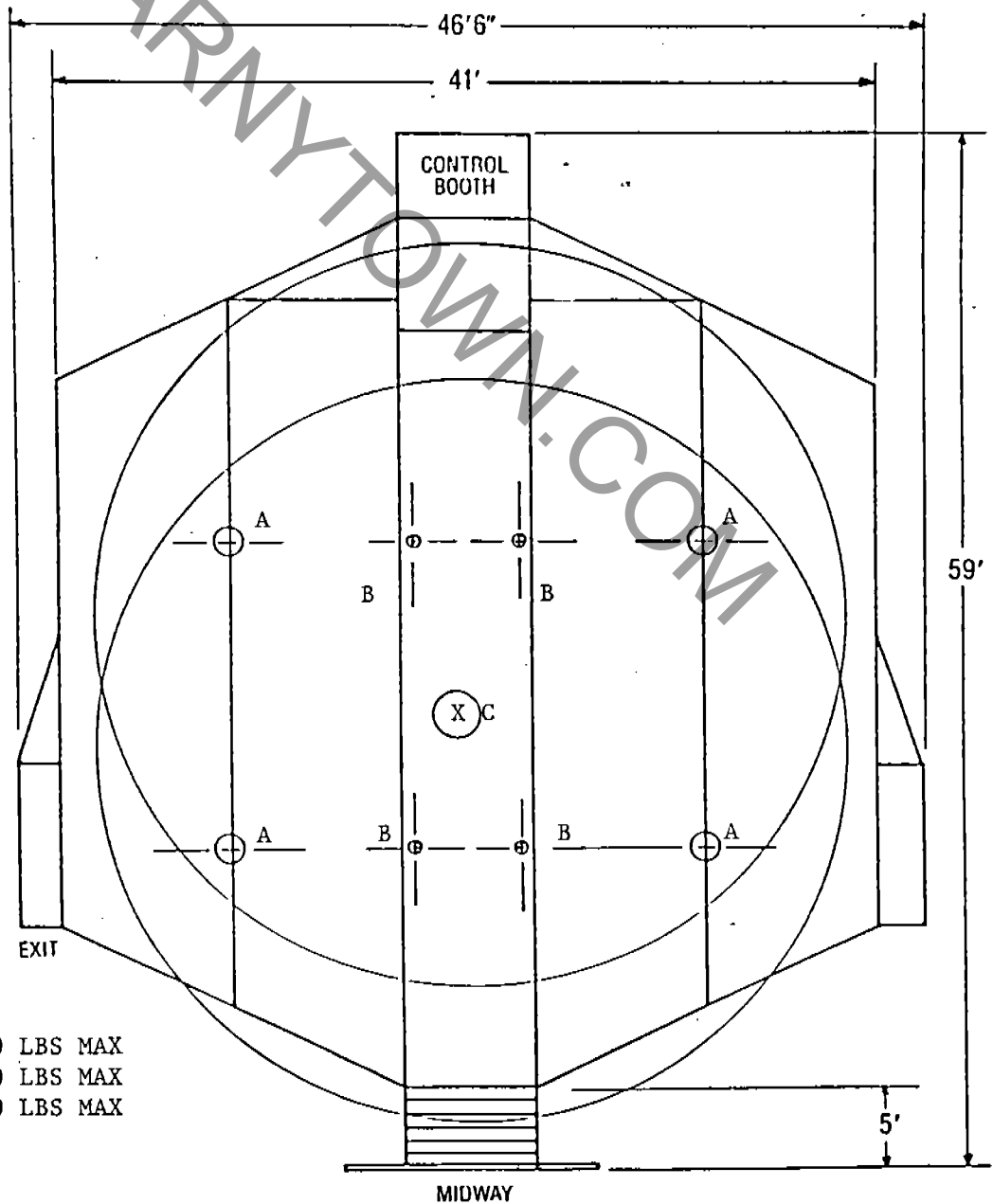

A 11,000 LBS MAX
B 11,000 LBS MAX
C 23,000 LBS MAX

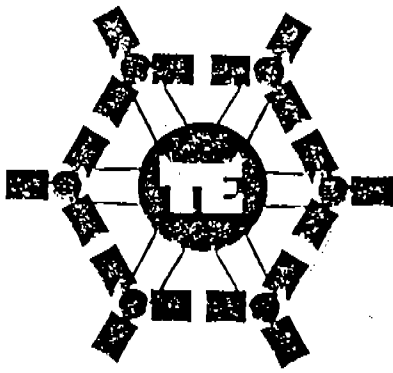

Tivoli Enterprises Ltd

Howfield Lane, Chartham, Canterbury, Kent CT4 7HG England.
Telephone: 0227 731156

B U L L E T I N

TO ALL FORCE 10 OWNERS

During a routine inspection performed by the State of Illinois, a crack was detected on the lower tilt cylinder attachment plate of the Force 10 Amusement Ride. In order to maintain the highest degree of safety standards, we feel it necessary to add a reinforcing plate in the area where the crack was detected. Drawings, specifications, instructions for installation and a "Certificate of Completion" are enclosed. The reinforcing plate is being shipped by U.P.S.

It is required that all owners of the FORCE 10 have this plate installed immediately. Installation should be made by a certified welder and the "Certificate of Completion" must be mailed to TIVOLI ENTERPRISES LTD., c/o Exsaco Corporation, P.O. Drawer 328, Alvarado, Texas 76009 within 30 days.

We will appreciate your co-operation.

Tivoli Enterprises Ltd.

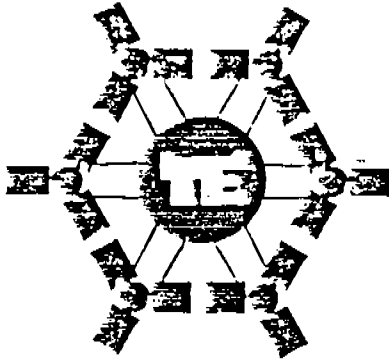

Tivoli Enterprises Ltd

Howfield Lane, Chartham, Canterbury, Kent CT4 7HG England.
Telephone: 0227 731156

NUMBER 00103

DATE JULY 8, 1988

SERVICE BULLETIN

RIDE FORCE 10 SERIAL NUMBER ALL
SUBJECT SAFETY SYSTEM ADJUSTMENT

ADJUSTMENT OF SAFETY SYSTEM FOR FORCE 10

The Force 10 Amusement Ride incorporates many safety systems to protect the ride occupants during a power failure, emergency shut down, or "control failure". Listed below is a explanation of each system along with any adjustment information required. It is EXTREMELY important that this system be checked for proper operation daily. Failure to keep system operating properly can cause damage to equipment and possibly injury to riders.

1. BOOM DECENT LIMITING PINS

Location - These pins are located approximately four (4) feet up the boom from pivot shaft. There are two (2) pins located on each side of the main boom.

Purpose - These pins are designed to stop the descent of the main boom any time the tilt box is tilted out over 3/4 inch. They prevent the ride seats from coming in contact with floor in case of cylinder failure or hose failure.

Type - This is a mechanical safety system that is operated through a series of linkage rods and springs that mechanically allow the pins to extend when the tilt box is operated.

Inspection - The linkage rod springs and rod end bearings should be inspected daily to assure proper operation. Inspection should be made for bent or broken rods, bearings, or springs. Linkage pivot points must be lubricated and kept clean.

Operation - For testing of safety pins, the control key at the operator's station must be turned off. By operating the main boom lift solenoid hydraulic valve (manually operated by inserting pin in each of coils), raise boom until safety pins are clear of platform. When clear by at least six (6) inches, stop raising boom. Next manually operate tilt hydraulic valve. Tilt sweeps until pins extend. (Pins should extend completely, shifting rod should touch end of slot in pin housing, when hydraulic tilt cylinders have extended. Pin linkage is factory set and should require no adjustment. If pins are not working properly, inspect linkage springs and bearings. If no irregularities are found, re-adjust pin via adjustment nuts located under main boom near tilt box.

Shear Pin - Located above adjustment nuts where linkage attaches to pivot lever. The linkage is equipped with a brass shear pin to protect linkage from damage if tilt box is tilted back before weight of boom is lifted off pin. If this pin is damaged, replace immediately.

If there are any questions or if further assistance is required, please contact the manufacturer.

POWER FAILURE VALVE

The Force 10 is equipped with an electro hydraulic valve which remains active as long as motor and control current is in use. In the event of a power failure, this valve de-energizes allowing the hydraulic fluid to exhaust from the bottom port of the main boom hydraulic cylinder and flow directly to the top ports of the tilt cylinder. By this action, the tilt box is forced back to the closed position while the main boom lowers under its own weight.

Testing - Unplug fast rotate hydraulic valve, operate, when fast speed button is pressed, ride will stop turning, wait 20 seconds, then boom will automatically raise. When boom raises completely, and tilt box tilts up parallel to floor and stops, immediately turn main switch off. From the moment the switch is turned off, ride should take 38 to 40 seconds to tilt down and boom to lower completely. If this test exceeds 40 seconds, please read the following paragraph concerning adjustment.

Adjustment - If tilt box and boom will not lower within the recommended time period, adjustment must be made via the safety relief valve located above the safety valve. (Below safety valve on new models.) Note: Ride will not lower at a rate exceeding that of the flow control valve located at the bottom of the main lift cylinder. If ride will not lower in 38 to 40 seconds, it may be necessary to adjust flow control of bottom port of main cylinder. If this is necessary, please contact manufacturer for instructions.

If there are any questions or you are in need of further explanation, please consult manufacturer.

EMERGENCY STOP BUTTON

Purpose - The Emergency Stop Button is located on the operating control and is designed so that if it is deemed necessary by operator that the ride be shut down quickly, the operator would push the red emergency button and ride will come to a quick level stop in the up position. This means that whenever the button is pushed, the ride will immediately level itself (any time the boom is above 30° point) and come to a normal stop. To lower the ride, after it has come to a complete stop, remove key from control and insert in emergency key slot. By turning key, ride will fold and lower under it's own weight.

Inspection - For this system to work properly, the pendulum and the proximity switch, located on side of switch box, must be clean and pendulum must move easily. It is also important to inspect all exposed wiring to assure no electrical wire has been chaffed or broken. If any wire is found to be in this condition, replace immediately.

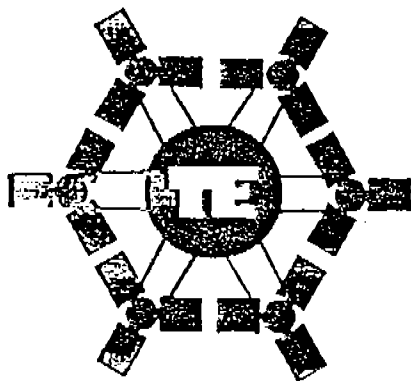

Tivoli Enterprises Ltd

Howfield Lane, Chartham, Canterbury, Kent CT4 7HG England.
Telephone: 0227 731156

23rd May, 1988.

TO WHOM IT MAY CONCERN

RE:- FORCE 10 seat hangers.

SAFETY FACTORS:-

10 - 1 on yield.

20 - 1 on shaft.

20 - 1 on ultimate on base material load
carrying capacity.

Life design stresses have a factor of 4 on allowable
fluctuations.

For and on behalf of:-
TIVOLI ENTERPRISES.

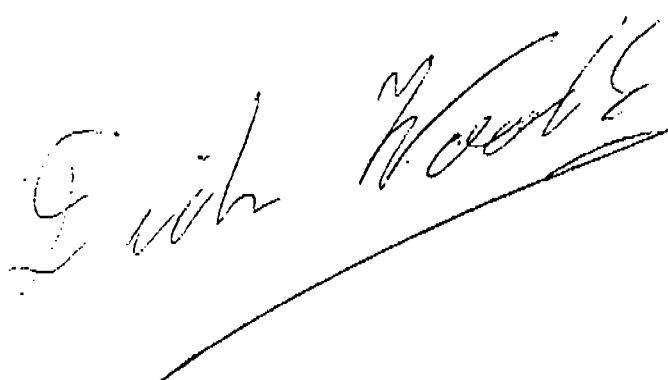
A handwritten signature in cursive script, appearing to read 'G. W. Wood', is written over a horizontal line.

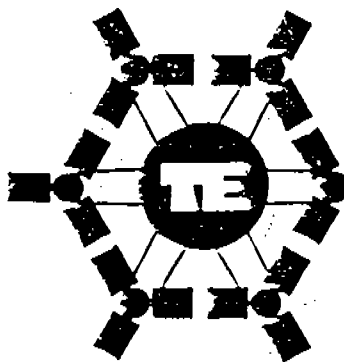

Tivoli Enterprises Ltd

Howfield Lane, Chartham, Canterbury, Kent CT4 7HG England.
Telephone: 0227 731156

NUMBER 00108

DATE 1-16-90

SERVICE BULLETIN

RIDE FORCE 10

SERIAL NUMBER ALL

SUBJECT LATCH SPRING SAFETY CABLE

It has come to the attention of Tivoli that there has been instances where the lap bar spring of the Force 10 has broken, causing the spring to fly off the ride resulting in possible injury to passersby. Tivoli recommends that a wire rope be installed to keep spring parts from flying off ride. Clamps should be installed as illustrated:

Required per seat
1 1/8"x 3' wire rope
2 1/8" wire rope clamp

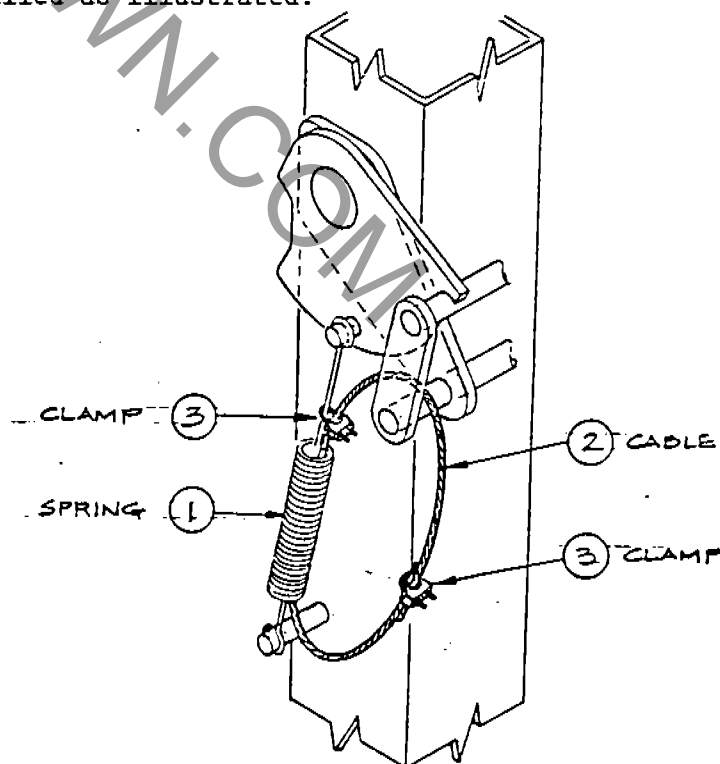

These parts can be purchased through Exsaco Corporation,
One North Santa Fe Street, Alvarado, Tx 76009.

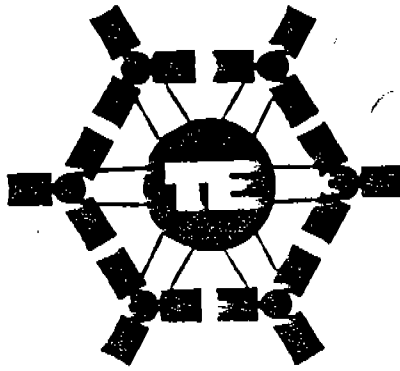

Tivoli Enterprises Ltd

Howfield Lane, Chartham, Canterbury, Kent CT4 7HG England.
Telephone: 0227 731156

SERVICE BULLETIN

RIDE: Force 10

DATE: 1-16-90

SUBJECT: Latch spring safety cable

BULLETIN NUMBER: 00108

It has come to the attention of Tivoli that there has been instances where the lap bar spring of the Force 10 has broken, causing the spring to fly off the ride resulting in possible injury to passersby. Tivoli recommends that a wire rope be installed to keep spring parts from flying off ride. Clamps should be installed as illustrated:

- Required per seat
1 1/8"x 3' wire rope
2 1/8" wire rope clamp

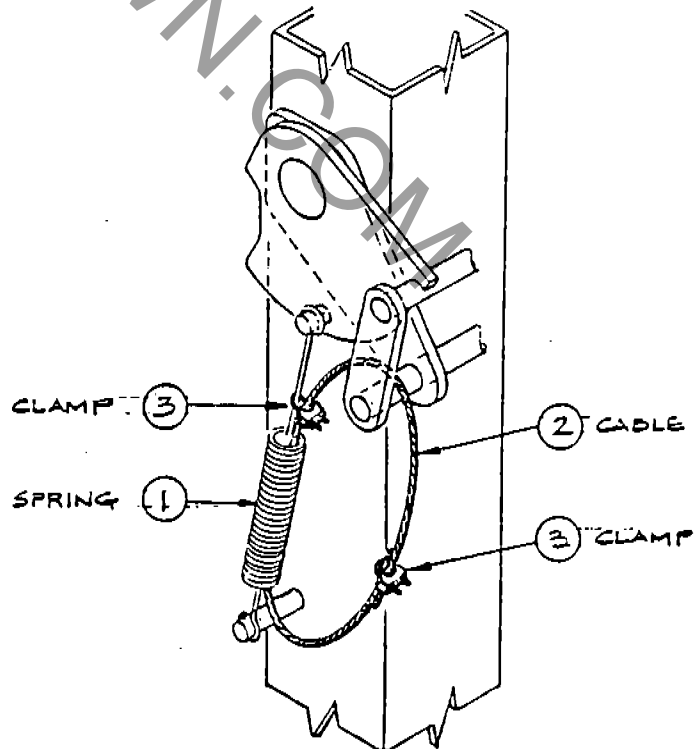

These parts can be purchased through Exsaco Corporation,
One North Santa Fe Street, Alvarado, Tx 76009.

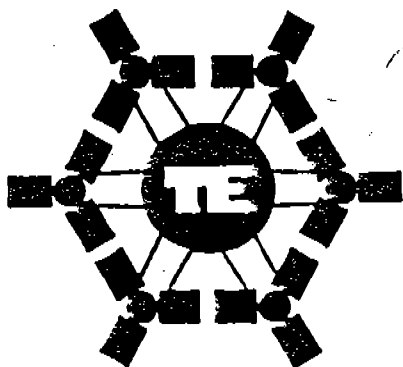

Tivoli Enterprises Ltd

Howfield Lane, Chartham, Canterbury, Kent CT4 7HG England.
Telephone: 0227 731156

SERVICE BULLETIN

RIDE: Force 10

DATE: _____

SUBJECT: Tilt Cylinder Pivot Pin
Attachment Frame

BULLETIN NUMBER: T1001

TO ALL FORCE 10 OWNERS

During a routine inspection performed by the State of Illinois, a crack was detected on the lower tilt cylinder attachment plate of the Force 10 Amusement Ride. In order to maintain the highest degree of safety standards, we feel it necessary to add a reinforcing plate in the area where the crack was detected. Drawings, specifications, instructions for installation and a "Certificate of Completion" are enclosed. The reinforcing plate is being shipped by U.P.S.

It is required that all owners of the FORCE 10 have this plate installed immediately. Installation should be made by a certified welder and the "Certificate of Completion" must be mailed to TIVOLI ENTERPRISES LTD., c/o Exsaco Corporation, P.O. Drawer 328, Alvarado, Texas 76009 within 30 days.

We will appreciate your co-operation.

Tivoli Enterprises Ltd.

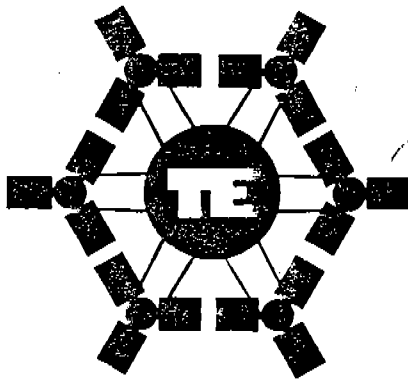

Tivoli Enterprises Ltd

Howfield Lane, Chartham, Canterbury, Kent CT4 7HG England.
Telephone: 0227 731156

15th October 1986

Dear Sir,

Re crack in welds on FORC E 10 tilt cylinder
mound brackets.

Please carry out modifications requird marked
out in red on blue print W505 48 as soon as
possible.

Stress analysis enclosed for modification.

Mild steel bars prepared and supplied in
material 43A to be welded by qualified personel.
All paint to be removed before welding.

Detail XX in red to be cut back to a depth of
2 inches to allow access for welding.

Any items such as winch, found to be in the
way are to be relocated to allow modifications
to be carried out correctly

For and on Behalf of Tivoli Enterprises
co. ltd.

FORCE 10. (TIVOLI./ EXASCO)

The FORCE 10 ride is equipped with safety devices that are controlled either hydraulically, electrically or mechanically.

All information concerning inspection and maintenance of these systems will be explained in their particular section.

This section deals in the inspection and adjustment of all mechanical devices and ride structure. Each part of the ride will be explained and information will be given as to the frequency of inspection. It is always a good practice to have daily visual inspection of all parts of the ride before operation to insure that ride has not been tampered with while unattended.

MAIN BOOM.

Safety pins: The Force 10 is equipped with a set of two 6" DIA. steel pins. These pins extend from the lower part of the main boom when the ride is in the full up position and the tilt box starts movement. This is a safety device that prevents the main boom from lowering completely if the tilt box is not in the retracted completely position.

It is necessary to inspect the operation of these pins before each day of operation. To accomplish this, the following procedure must be followed:

1. Turn on hydraulic system electric motor.
2. Manually operate raise boom hydraulic valve.
3. Raise main boom until safety pins clear platform by one inch.
4. Manually operate tilt up hydraulic valve until pins have extended to their full position.

Pins should move easily and project at least two inches over sub frame. Extension of pins should start within 3/4" extension of tilt hydraulic cylinders.

FORCE 10.

If any of these points are not within the limits, corrective action should be taken. Visually check linkage, check for bent linkage, loose bolts, or anything out of the ordinary.

Linkage is fitted with a brass shear pin located at top of boom before tilt box. This is to prevent damage to linkage in the case of accidental manual movement of linkage, while weight of ride is on pins, or boom is in lowest position and pins are extended. If pin is sheared, replace immediately.

Adjustment of pins: In the rare event the pins become improperly adjusted, it will be necessary to readjust to be within the two inch limit. To accomplish this, loosen lock nuts on adjustment rods located under top end of main boom. Adjust by turning nut until pins are extended to proper length. Each pin ^{must} ~~has~~ to be adjusted independently.

*Important: If pins need to be adjusted, check ride thoroughly prior to adjustment. Linkage is factory set, and should never require adjustment. Misalignment is usually caused by shear pin breakage or damaged linkage.

SEATS

Inspect security of seat pins and safety "R" keys daily.

Seats are fitted with a removable upper portion which can be removed for inspection of seat under frame. Seat under frames should be inspected annually.

LAP BAR MECHANISM

Daily inspection of lock mechanism operation, springs and lap bar foam. Springs should be checked for excessive corrosion and over stretching. It is recommended that all lap bar springs be replaced annually.

SWEEP AND BRACE PINS

Daily inspection of all sweep pins is necessary to insure all pins are safely keyed ("R" key) or cotter pinned.

SWEEP AND SWEEP BRACE BUSHINGS

This ride is equipped with bronze "T" bushings on all sweep brace and sweep ends to minimize pin wear. During every set up, bushing in which pins are removed should be checked for cracks from improper pin installation. If cracks are detected, replace bushing immediately.

SEAT HANGER HINGE PINS

Pins are located at hanger joint where main sweep meets car hanger frame. Daily visual inspection and maintenance is necessary to insure safe and proper operation. The following points should be checked daily as part of normal inspection procedures.

1. Inspect pin securing plates (2), each plate has two bolts. Check all for tightness. Look for plate wear.
2. Check for proper lubrication. (Lubrication required daily)
3. Inspect area around pin for any defects.
4. Check for excessive play between pin and bushing. This is accomplished by pushing lowest portion of seat hanger frame in a parallel direction with pin. Side to side play should not exceed 1"

If it is discovered that play exceeds the maximum restrictions, disassemble seat hanger frame from sweep. Inspect security plates, pin diameter, and bushings. When worn part is detected, replace immediately.

CARNYTOWN.COM

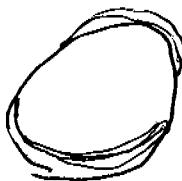

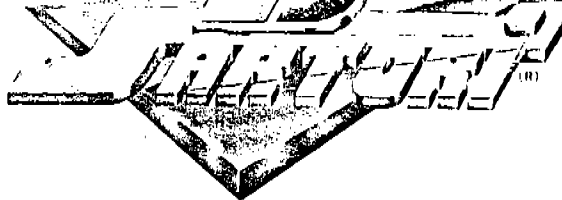

☆☆☆

C.C.I.A.A. N. 207649
TRIBUNALE PD N. 29066
Codice Identificativo CEE
IT 01359760285

Modello di riferimento - St. 04.10.1984 (Art. 17)
Modello di riferimento - St. 04.10.1984 (Art. 17)

CRAZY SURF

MOD. RS / 380

CARNY-TOWN.COM

USE AND MAINTENANCE MANUAL BOOK



SUPPLIER OF EQUIPMENT FOR AMUSEMENT PARKS

INDEX

- 1) Introduction
 - 1.1 Guide to the consultation
 - 1.2 Use of the ride
- 2) Instructions against accidents
 - 2.1 Instructions against accidents during assembling and dismantling
 - 2.2 Instructions against accidents during operation
- 3) General drawing of the ride
- 4) Operation of the ride
 - 4.1 Checkings and advises before starting
 - 4.2 Starting
 - 4.2.1 Electric connections
 - 4.2.2 Start
 - 4.3 Adjustments and regulations
 - 4.4 Working anomalies
 - 4.4.1 General anomalies
 - 4.4.2 Transmission anomalies
- 5) Maintenance
 - 5.1 Periodical maintenance
 - 5.2 Transmission
 - 5.3 Reduction gear
 - 5.4 Sprocket bearing .
 - 5.5 Pneumatic installation
 - 5.6 Electric installation
 - 5.7 Braking installation
 - 5.8 Car
 - 5.9 Inspections after using
- 6) Inactivity
 - 6.1 Preparation to stop
 - 6.2 Restarting
- 7) Technical notes
 - 7.1 Technical tables
 - 7.2 General features

1) Introduction

1.1 Guide to the consultation

The use of the "Use and maintenance manual book" is a guide for the operator for a correct operation of the ride. This manual contains all the rules the operator has to follow carefully before, during and after each use of the ride in order to assure his own and riders' safety.

We remind that this manual must always be together with the ride and that the operator is obliged to read it before installation and starting.

If you do not understand some parts of this manual please contact our technicians for any explanation.

1.2 Operation of the ride

The operation of the ride must follow all the rules fixed by our Company, a whatever different use is considered contrary to the primary use.

The ride has to be started only by adult (over 18) operators which also has to know its particular features and the principal safety rules.

We decline all responsibility for any arbitrary modification producing damages to persons and things.

2) Instructions against accidents

2.1 Instructions against accidents during assembling and dismantling

Before beginning with the assembling of the ride the operator/s have to know the following safety rules.

The operator must consider that some dangers are connected with an improper use of the ride, in order to avoid serious dangers for himself and for the public.

Our Company provides the following instructions to be observed :

- Before beginning the assembling make sure that in the set up area there are no high-voltage wires, trees or any other element which can represent a danger for the assembling or working of the attraction.
- During assembling must not be in the working area non authorized persons.
- Assembling and dismantling must be done by qualified personnel.
- Take care to hanging loads and before operate make sure that the load to lift is properly fixed to the equipment.

2.2 Instructions against accidents during operation

As to rules against accidents to be followed during operation, our Company provides the following prescriptions and restrictions :

- The personnel who attends to the ride must be adult (over 18), qualified and must know everything written in this manual.
- Before opening the ride to the visitors the operator will have to let the ride turn empty for some minutes so to check if all safety devices are efficient.

- Check if START-STOP-EMERGENCY devices work properly.
- In no case may the operator leave the ticket booth when the ride is working. If he has to go he will have to be replaced by experienced personnel.
- Before each ride check if all safety fences are properly closed.
- Before each ride make sure that nobody stands or come close to the operational area of the ride.
- Do not load the car if it is unbalanced.
- Do not give the car an excessive speed i.e. higher than allowed.

MAX. ALLOWED SPEED 24 RIDES/MIN., RECOMMENDED 20/22 RIDES/MIN.

To this purpose controls are provided with electronic boards which prevent this. It is absolutely forbidden to modify the electronic boards or to take off eventual seals. Before lowering riders fences, make sure that everybody sits properly in his seat.

NOBODY MUST BE STANDING WHEN FENCES GO DOWN

In case while working a passenger tries to get off the operating ride or others try to go on, stop immediately the ride through the emergency button.

IMPORTANT

The ride has not been planned and therefore is not suitable to younger than 14 year old children and to handicapped persons. Anyway the operator has to decide what people can go on to the ride.

Near these prescriptions the operator must consider the following restrictions for the riders :

- No smoking on the ride
- You have to leave at the cash whatever object which can fall during working. For this purpose expose at the entry a signal of advice.
- Do not let on the ride people in drunkenness or anyway fisisally altered.

Near the above rules the operator has to follow all those imposed by the country where the ride will operate.

3) General drawing of the ride

MAX. WIDTH IN OPERATION MT.5,6 - FEET 18,6

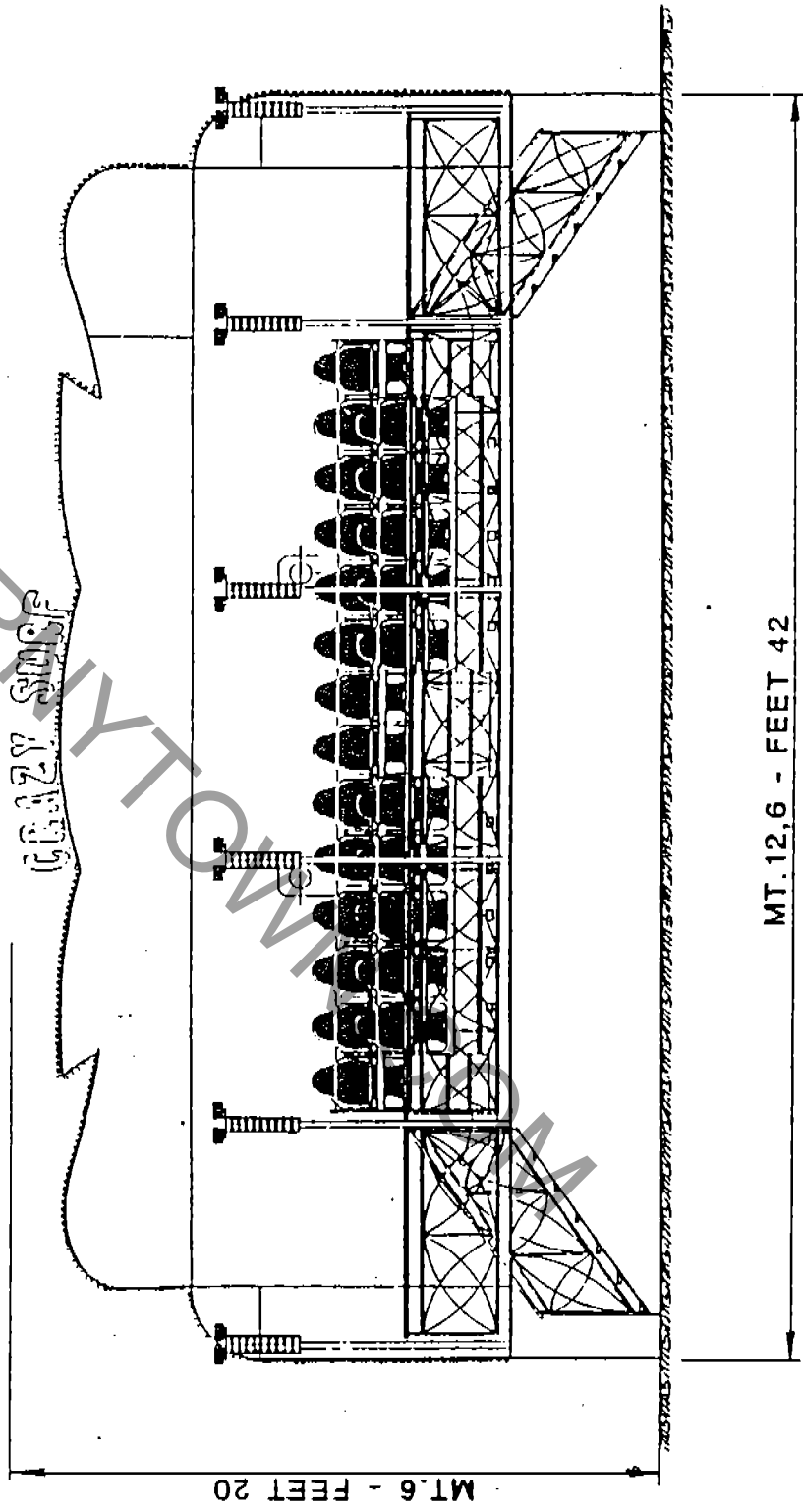

IN OPERATION MT.6,1 - FEET 20,3

4) Operation of the ride

4.1 Checkings and advices before starting

Before starting some important details must be taken into consideration.

a) Before each use check the proper leveling with the stabilizers on the trailer.

We remind that each stabilizer must have a 5 cm. wooden piece underneath to easily level the trailer. Such operation is very important for riders safety in order to avoid inconvenient strain which could damage the ride structure.

DURING A DAY CHECK SEVERAL TIMES THE LEVELING OF THE RIDE

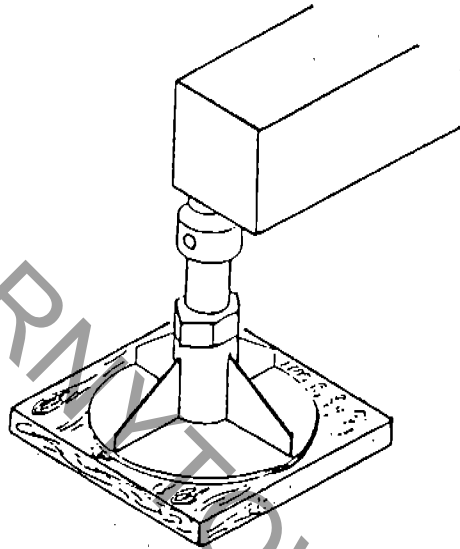

b) Before starting check if the ground mass is connected, do not give power to the board if ground mass is not connected.

The ground mass connection must be done by qualified personnel and follow the rules in force.

c) We recommend to check before operating all safety and operation buttons. In case a control does not work do not open the ride to public before adjusting it.

d) Check if all plugs in the electric installation are properly connected.

e) Check if all safety pins have their safety split pins and are properly connected.

f) Before opening the ride to public check the connections of the screws of the arms counterbalance, the fixing of the screws between car and arms.

g) Check the plugs and the split pins of the locks.

h) Check the efficiency of the braking motor.

i) Before opening to public let the attraction ride for some minutes to check if all controls work and if there are conditions which could be dangerous to public.

IMPORTANT

FOR PASSENGERS AND RIDE STRUCTURES SAFETY, WE ADVISE TO CHECK EVERY 15 DAYS THE MAINTENANCE OF THE INSIDE ELEMENTS IN EACH CONNECTION BETWEEN CAR AND ARMS, WITH PARTICULAR CARE WHEN CHECKING ALL WELDINGS AND THE INSIDE ANTI-VIBRATION MATERIAL; IN ANY CASE MAKE SURE THAT THERE ARE NO ANOMALIES IN THE STRUCTURE OR OF ANY OTHER ORIGIN. EVENTUAL ANOMALIES SHALL NOT BE IGNORED, CHECK CAREFULLY THE CAUSES FOR SUCH ANOMALIES AND DO NOT LET THE ATTRACTION OPERATE UNTIL THE DANGER IS REMOVED.

EVERY 15/20 DAYS CHECK THE WEAR OF THE SPROCKET BEARINGS AND OF BOTH TRACTION PINIONS, THIS CONNECTION MUST ALWAYS BE GREASED OUTSIDE ON THE SPROCKET AND INSIDE WITH THE PROPER GREASERS.

A GENERAL SAFETY SYSTEM CONSISTS OF FITTING A CHAIN IN THE ROTATION COMPONENTS. THIS CHAIN MUST ALWAYS BE GREASED.

CARNY TOWN.COM

4.2 Starting

4.2.1 Electric connections

Before starting some checkings are needed.

Check power and if the ground mass is connected.

4.2.2 Start

Once all safety conditions above are verified lift the general switch of moving power and the light switch 220/110V, of field (FIELD) and fan (FAN).

Check now the phases sequence with the red led on the test sequence phases, if it is on, switch off the general switch and the principal power line and then proceed to reverse one phase per time until the light of the led is off.

N.B. Make sure that at each reverse the power is cut off.

Check if all leds of the main converter excluded the led of net POWER are off.

To start the ride act as follows :

- Push RESET (yellow) button and see if the yellow light signal is on, on the control board.
- If it does not switch on check all starting leds.
- Make sure that nobody is in the operational area, check that the speed selector is on zero position and wait that all riders sit properly in their seats.
- Close fences using its button, push BELL button to inform riders of starting, push START button and adjust speed.
- In case of danger the red button EMERGENCY cuts off power in all components of the ride.

4.3 Adjustments and regulations

4.4 Working anomalies

4.4.1 General anomalies

Hereafter are described some inconvenients which may happen to the ride and the relative remedies.

THE ATTRACTION DOES NOT RESPOND TO START CONTROLS

Check on the general board the displays of the sequence phases, in case some alarms (red led) are on, proceed after having cut off the main power supply, to reverse one phase per time untill all alarms are off.

This attraction is provided with some safety systems in order to avoid damages in the mechanic and electronic system. These anomalies are shown in the lighting display on the main converter. Hereafter are described the possible causes of alarm.

Signal **POWER**

Electronic supply

Signal **ENABLED**

Qualification of the converter

1. Signal **I MAX**

Maximal instant overpower intervention of 110% over the nominal.

The more possible cause for this effect may be the car which has been loaded too much, or the rotation speed has exceeded the maximum allowed limit.

2. Signal **N-MAX**

Maximal overspeed

It is better to remind to the operator to give to the attraction a speed not higher than allowed.

5. Signal **OVER-TEMP**

Check the correct working and direction of the motor fan c.c. and the fuse.

If they are both correct we suggest to ask qualified people to check the motor temperature thermostat. In case of too high environment temperatures, we recommend to keep opened the general board.

6. Signal **FIELD-LOSS**

In order not to cause serious electric damages, the following operations must be done with no power in the ride.

Check the three fuses sequence phase.

Check the correct insertion of the connections of the field excitation boards placed on the upper part of the converter **ANSALDO** and of the terminals **ECC+** and **ECC-** in the terminal box placed on the bottom part of the general board.

If these controls are correct we recommend to proceed as follows :

- Place an ammeter in series between the terminal **ECC+** and check the **RANGE OF POWER** which must be of **4A** exactly, if they are more or less, turn the trimmer **P2** in the field excitation board (**SPEED 1A**) of the converter **ANSALDO**.

7.Signal **PH-LOSS**

Check the net sequence phases and the correct voltage. Furthermore make sure no phases are missing or power fuses have to be replaced.

8.Signal **EXT.FAULT**

Check the ventilation of the cooling motor and the connections of the pressure switch monostat placed at one side of the cooling motor cc. Moreover check the pressure regulator which must not be less than 6 and the connections of the terminals on the general board.

The lights of the subject do not work.

Check the fuses and the right insertion of the electric connections.

4.4.2 Transmission anomalies

Hereafter are listed some problems which may happen in the transmission and particularly in the motor.

Motor does not start empty

Causes for this problem may be different :

- Coils in short circuit
- Interrupted main field
- Bad contact between brushes and commutator

Possible solutions are : to remake the main field, to repair or rewind the inducted and to check the worn brushes replacing them.

Motor turns release

In this case the coil of the inducted is in short circuit or the commutator plates are in short circuit too. To avoid this inconvenient the only solution is to repair or rewind the inducted or to clean the room between the plates.

Motor does not start coupled

The causes of such inconvenient are mainly :

- Overload
- Machine with brushes out of neutral zone
- Series rewind opposite to the inducted current

Possible solutions are to check the absorbed current and to repute the brushes in the neutral zone.

NOTE : The control of the correct position of the brushes must be done only after dismantling the brush-holder unit and after a careful work of remaking of the commutator (facing).

Closing the rewind switch of the field a tension impulse is given to the armature.

If brushes are in the neutral zone, tension read between both opposite sign brushes is null. At the contrary such position must be reached unscrewing the screws blocking the brush-holder arch to the shield and varying the angle position, reaching the right position.

The voltmeter used should be in central zero position and have two ranges : 0 - 1,5V for the rough setting-up and 0 - 60mV for the refinement.

Brushes must be perfectly suitable to the commutator.

For any other question not mentioned in this manual book, please contact our Company, our technicians will be at your complete disposal.

5) Maintenance

5.1 Periodical maintenance

Maintenance of the ride is important to get a proper operation at the lowest costs.
We recommend to follow the hereafter program suitable to a normal use of the ride :

The parts of the ride mentioned in this chapter are :

- Motor
- Reduction gears
- Sprocket bearing
- Pneumatic installation
- Electric installation
- Braking installation
- Car

5.1.1 Transmission

Concerning maintenance of all transmission components, it is advisable to follow the program mentioned hereafter and make sure before beginning any maintenance operation to cut off the power in the control board in order to avoid serious damages to people.

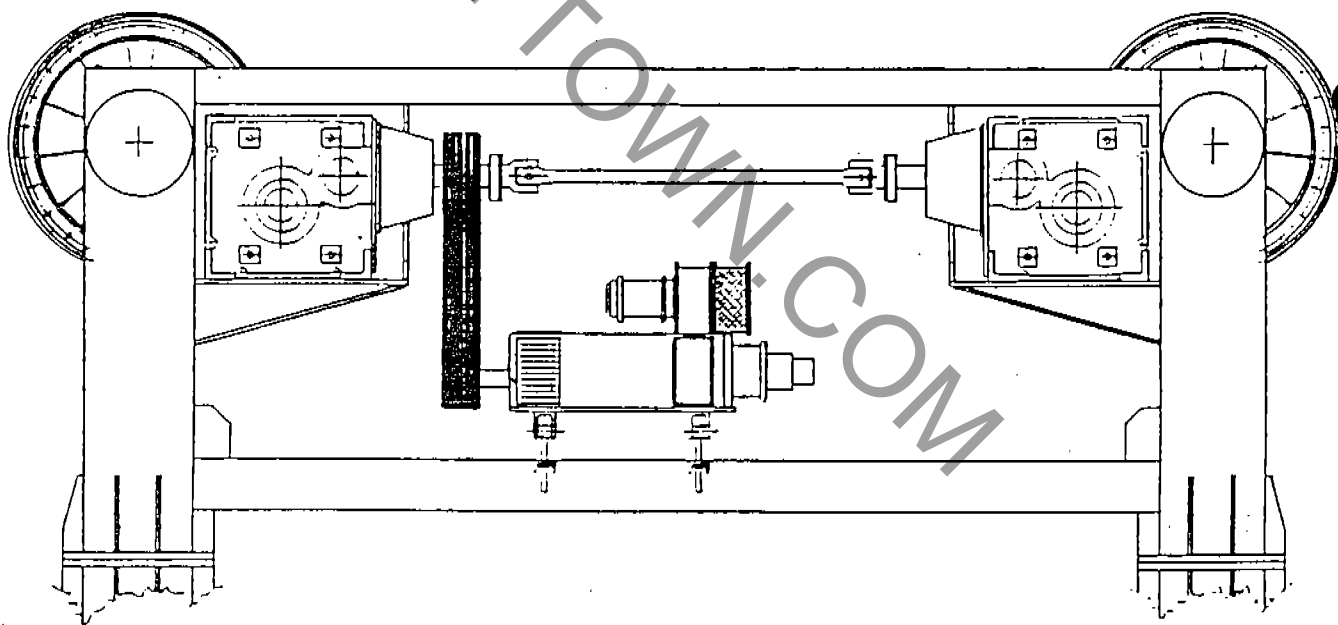

5.1.1.1 Motor

Motor is one of the most important components of the transmission and need a special maintenance program.

We examine now carefully maintenance and control phases for brushes and bearings.

a) Brushes

The visual inspection of the commutation is the first step to find out possible malfunctions in the machine and in its power supply system; an immediate evaluation enables to take the proper measures thus preventing abnormal brush wear and commutator scoring.

Usually the commutator adjustment is performed in a testing room, first by supplying the machine with direct current (form factor = 1) and then through a fully controlled three-phase bridge. The degrees of sparking referred to the testing room are listed in the figure.

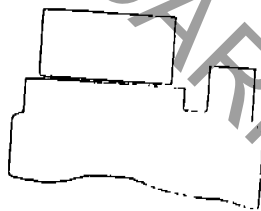

fully black commutation

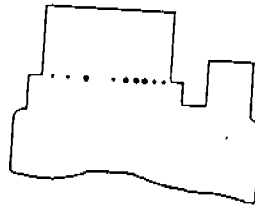

light intermittent sparking

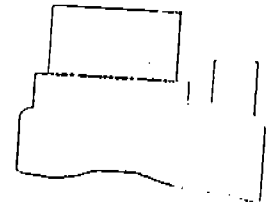

light continuous sparking

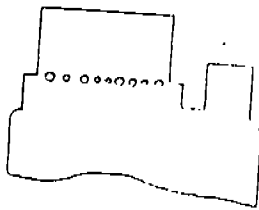

lively continuous sparking

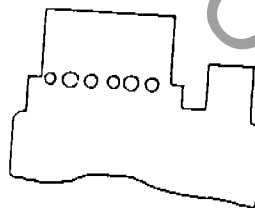

violent sparking

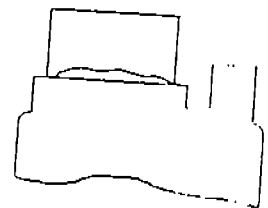

incandescent

In particular are accepted the degree 1 (with complete black commutation) for dinamo supply and the degree 1 - 1/4 (slight intermittent sparkling) for supply in three-phase fully controlled bridge. Obviously the complete range of working conditions cannot be reproduced in the testing room; for this reason sparkling degrees different from those listed can usually be admitted for special and intermittent services (quick current inversions, braking, etc.) but never for continuous use. In case of power supplies different from fully controlled bridge current converters, also control the existence and correct sizing of the leveling impedance coil. A commutation within the above tolerances involves also a regular brush wear as shown in the picture.

BRUSHES WEAR DRAWING

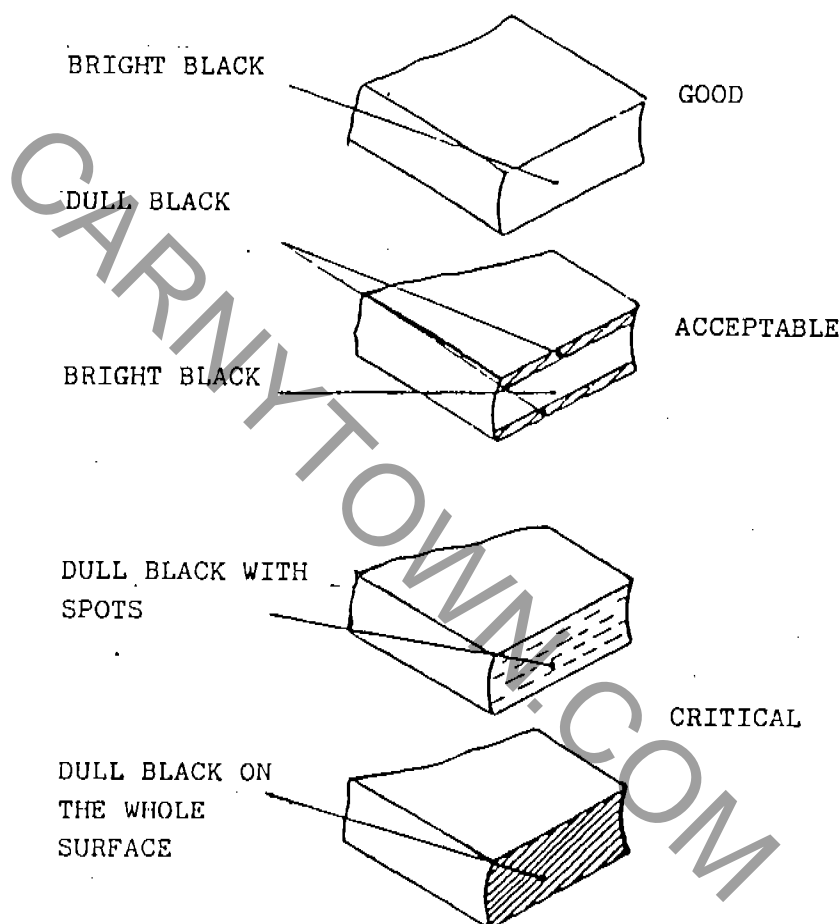

In order to have a regular brushes wear it is necessary that :

a) The load is near the nominal value. In fact a too low load may cause scorings; on the contrary a too high load causes craters and burning on the sliding surface. Besides since the number of brushes is chosen according to the nominal load, if the machine does not operate under these working conditions check the brush wear from time to time : if it is excessive do not hesitate to contact our technicians.

b) Pressure in the spring of the brush must be about 200-250 g/cm². Usually if the machine is subject to vibrations, it requires an increase of pressure. Check the free sliding of the brushes in their holders (play within 0,1 - 0,3 mm) and check the tightness of the electric connections.

A too low pressure may considerably increase both brush and commutator wear as a consequence of the increased losses on the sliding surface or of sparking.

If pressure is too high, mechanic wear prevails and there is a risk of commutator overheating due to increased friction losses.

If there are several paralleled brushes pressure must be the same for all in order to allow a regular current distribution. If pressure is not regular there is a danger that single brushes are overloaded, with consequent burning of the plaits and burst of the brushes.

b) Bearings

Maintenance of motor bearings is very important.

In this case you have to follow some rules concerning the type of grease to use, quantity and in case of substitution of one or more bearings, the type to use.

We remind that maintenance operations in the motor have to be done with no power.

During greasing operation an excessive quantity of grease must not be injected in the bearing because it could produce an anomalous heating of the bearing.

Greases suitable to be used are:

- Shell Alvania 2 and Shell Alvania 3
- Esso Beacon 2 and Esso Beacon 3
- BP Energrease L52 and BP Energrease L53
- Mobilux Grease 2 and Mobilux Grease 3

Lithium based greases with small additions of calcium are strongly recommended as they are water repellent.

In absence of special directions the grease must be changed every 6 months.

The bearings fitted on the motor are indicated in the following table:

Motor Type	SIDE COMMUTATOR						SIDE COUPLING			
	grease		grease	double axle	grease	joint coupling	pulley coupling	grease		
180	B3 - B5	g	V1 - V3	g	B3 - B5	g	B3 - B5 V1 - V3	B3 - B5 - V1 - V3	g	
	8308 2Z	0	8308 2z	0	8308 2Z	0	NU 312 ECP NU 312 ECP	NU 312 ECP	25	

When bearings need to be changed, be careful not to damage the bearing holder of the shaft.

5.3 Reduction gear

As to reduction gears maintenance the program is as follows :

a) check oil level in the reduction gear.

For this type of reduction gear we recommend to use gear oils with addition EP, minimum viscosity 95 and viscosity expressed following ISO 3448, which varies according to temperature, following data refer to ordinary cases :

Temperature $-20^{\circ}\text{C} +5^{\circ}\text{C}$
 class of viscosity VG 100
 Temperature $+5^{\circ}\text{C} +40^{\circ}\text{C}$
 class of viscosity VG 150
 Temperature $+40^{\circ}\text{C} +65^{\circ}\text{C}$
 class of viscosity VG 320

In case of big temperature variations, we recommend synthetic lubricants with EP, minimum viscosity 165 and viscosity class VG 150 or VG 220.

Anyway we suggest oils that do not get quickly worn at the respective temperature.

The change of oil in the reduction gear must be done the first time after 50-100 hours operation; subsequently every 2500 hours or at least every 12 months.

Depending on the effective work conditions the above periods can be varied case by case.

It is suggested to check monthly the oil level. In case of more than 10% lack, lubricant must be filled up. Please check if there are oil losses in the unit. It is suggested not to mix different types of oils, also of the same brand or different. In any case do not mix synthetic oils with mineral oils.

5.4 Sprocket bearing

As to sprocket bearing maintenance we recommend to make attention to the greasing of the same in order to avoid any friction, have a proper tight and protect from corrosion. We recommend to grease in order to have grease coming out from bearing and seal rings. In the following table are listed all suggested greases.

ARAL	Aralub HL 2	CHEVRON	Dura-Lith Grease 2
	Aralub LFZ 1		Pinion Grease MS
B.P.	BP Energrease LS2	ESSO	BEACON 2
	BP Energol WRL		SURETT Fluid4K
CASTROL	Castrol Spheerol AP2	GULF	Crown Grease 2
	Castrol Grippa 33S		LUBCOTE 2

Frequency of this operation must be chosen according to working conditions.

In general greasing operation must be done every 50 work hours. We recommend more frequent greasing in tropical countries, high humidity places, dusty places and with strong temperature changes or in case of a continuous rotation.

To compensate settling phenomena it is necessary to check if the blocking of the fixing bolts is in conformity with the standard. This check must be done within the first 100 hours operation and then it is advisable to do it every 300 hours or every 2 months work at least.

In addition to greasing the sprocket bearing, provide for a daily greasing of the external connecting side on the contact point between pinion and sprocket bearing.

5.5 Pneumatic installation

Maintenance of the pneumatic installation is very important for passengers' safety. Hereafter are listed some points to check.

- Before operating check if all fences are properly closed.
- Every week check the wear of the connections and the condition of the pipes.
- If necessary vary air pressure in order to get the optimal adjustment of the fences.

5.6 Electric installation

Maintenance of the electric installation is limited to the periodical control of the electric connections of light plugs and switches; remember that controls, repairing and test operations must be always carried out by qualified people. Non authorized people may not open electric boards and execute works when ride is on power. We recommend to the operator not to modify the electric installation and to change eventual electric pieces with proper material.

5.7 Braking installation

Braking installation does not need particular maintenance operations but only some check in before leaving from a site to another.

Checking operations to be made are :

- a) Check the proper operation of the brakes and of the rear stop lights.
- b) Check the welding of the axles of the trailer.
- c) Check pressure of the tires (max 9 atm.) and the blocking of the wheel nuts.

Please note that considering the wheel are new they need to be checked repeatedly while moving on road. Therefore check nuts on wheel as follows :

- 1° after 20 Km
- 2° after 60 Km
- 3° after 150 Km

and then every time before leaving.

5.8 Car

The parts to be checked on the car are listed hereafter.

We remind that maintenance of the car must be done by qualified personnel :

- Grease periodically all parts of the moving closing systems, such as : levers, pins, blockings, etc.
- Check the proper contact of the electric connection.
- Check the proper operation of all moving pistons and grease the compasses which joint them to the structure of the car.
- Check always the proper blocking of the car to the ride.

5.9 Inspections after using

After using some structural controls must be made in order to verify the perfect resistance of the structure.

To this purpose check all parts subject to rotation : thrust-blocks, car pins, check the operation of riders bars, the blocking of the screws which joint both rear capitals to the façade, the blocking of the screws of counter-weight arm, the efficiency of the structures which joint both parts of the façade; in addition to these controls the operator will have to check all parts on the trailer which are more stressed (i.e. axles, stabilizers).

All checking operations must be done by qualified personnel.

6. Inactivity

6.1 Preparation to stop

Before stopping the ride for a long period a general control of all structures must be made along with a cleaning work of all points subject to intense operation.

Check and clean motor and all its parts with particular care for brushes and air filter.

As to brushes, after checking and cleaning them we recommend to smear a small quantity of graphite-grease and for the air filter it is sufficient to clean it with compressed air.

Remember that these operations and the next must be carried out with no power.

Another component of the ride to be checked and cleaned is the reduction gear; afterwards pinions and sprocket bearings must be checked and greased with much grease in order to avoid corrosions in the material.

Grease all components in the closing system of the car; if there is dirty or encrustations we recommend a careful cleaning and greasing.

These are only some points to be checked before stopping the ride. They are recommended by us in order to get a proper preservation of the structure. Then the customer will have to decide where to make an intervention and in which measure.

6.2 Restarting

Restarting of the ride after a long inactivity period needs a work program directed to check the wear conditions of the components and to replace them if necessary. You have also to check the oil level in the reduction gear, the wear of the pipes in the different installations and the proper working of all controlled elements.

These operations must be made by experienced personnel without leaving any particular. Once checking operation is over begin with the assembly of the different structures and with the test of the ride. We remind that you must follow all safety rules described in this manual book.

7) Technical notes

7.1 Technical tables

Hereafter are enclosed the tables of the electric installation, the components list and the drawing of the braking installation.

Our Company reserves itself the possibility to vary some components in the installations of the ride without notice.

CARNYTOWN.COM

7.2 General features

Model	: trailer mounted
Sizes	: operating mt. 12,6 X 5,6 X 6,1 H
Lighting	: KW 12
Moving power	: KW 65
Rotation speed	: max 24 rides/min.
Cars	: n° 1
Places	: n° 24
Hourly capacity	: 800 riders approx.
Cubage	: 1 FLAT 40'
Weight	: 21000 Kg CA.
Transmission	: electromecanic

CARNYTOWN.COM

CRAZY SURF

MOD. RS/380

CARATTERISTICHE GENERALI GENERAL NOTES

- MODELLO : MONTATO SU CARRO
- MODEL : TRAILER MOUNTED
- DIMENSIONI : IN OPERAZIONE MT. 12,6 X 5,6 X 6,1 H
- SIZE : IN OPERATION FEET 42 X 18,6 X 20,3 H
- ILLUMINAZIONE : KW 12 CA.
- LIGHTING : KW 12 APPROX
- FORZA MOTRICE : KW 65
- MOVING POWER : KW 65
- VELOCITÀ DI ROTAZIONE : 24 GIRI AL MINUTO
- ROTATION SPEED : 24 RPM
- VEICOLI : 1
- VEHICLES : 1
- POSTI : 24
- SEATING : 24
- CAPACITÀ ORARIA : 800 PERSONE CA.
- HOURLY CAPACITY : 800 RIDERS APPROX
- CUBAGGIO : 1 FLAT DA 40'
- CUBAGE : 1 X 40' FLAT
- PESO : KG 19.000 CA.
- WEIGHT : LBS 42.220 APPROX
- TRASMISSIONE : ELETTROMECCANICA
- TRANSMISSION : ELECTRIC MOTOR

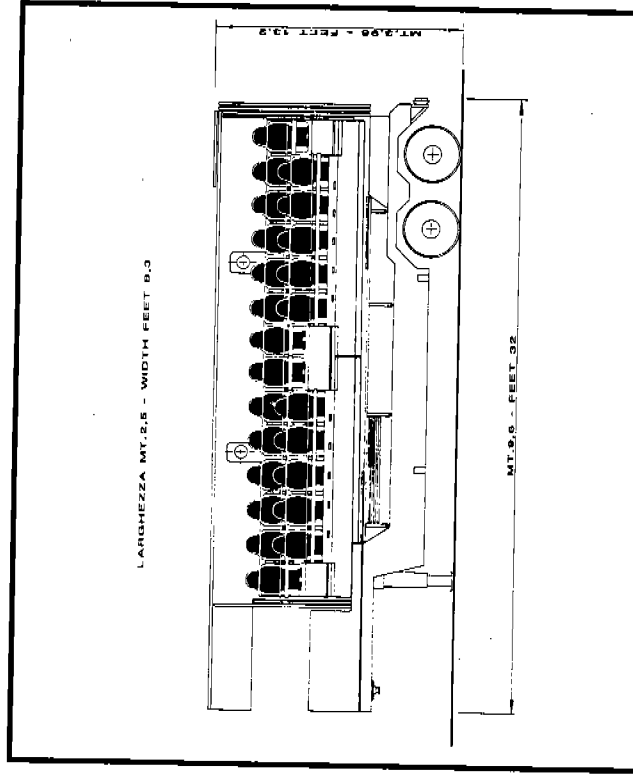
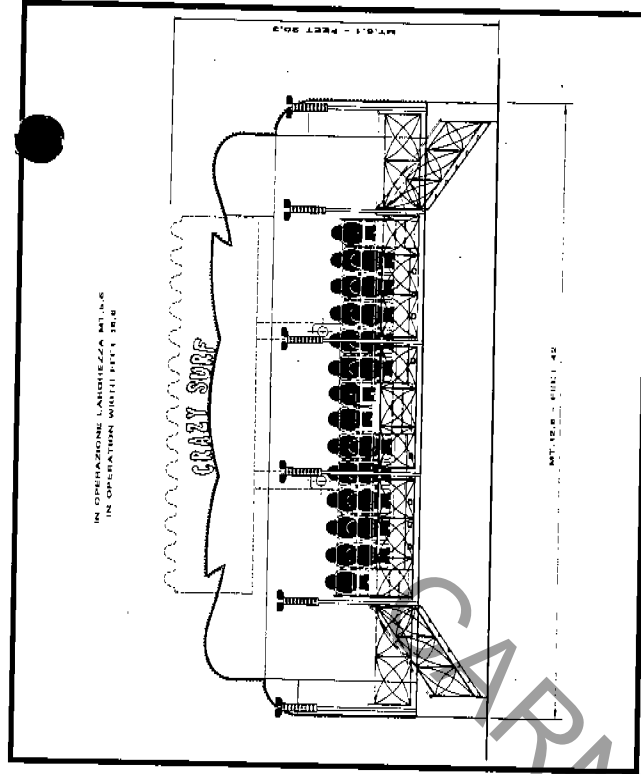

MANUFACTURERS OF AMUSEMENT RIDES

SARTORI

Main factory: SARTORI IMPORT-EXPORT S.p.A. - Zona Industriale - 35044 Montagnana (PD)
Italy - Ph. (0429) 800222 r.a. - Telex 430394 Sapark I - Fax (0429) 800333

THE GREAT ESCAPE

THE GREAT ESCAPE

**CRAZY
SUPPORT**

mod. RS/380

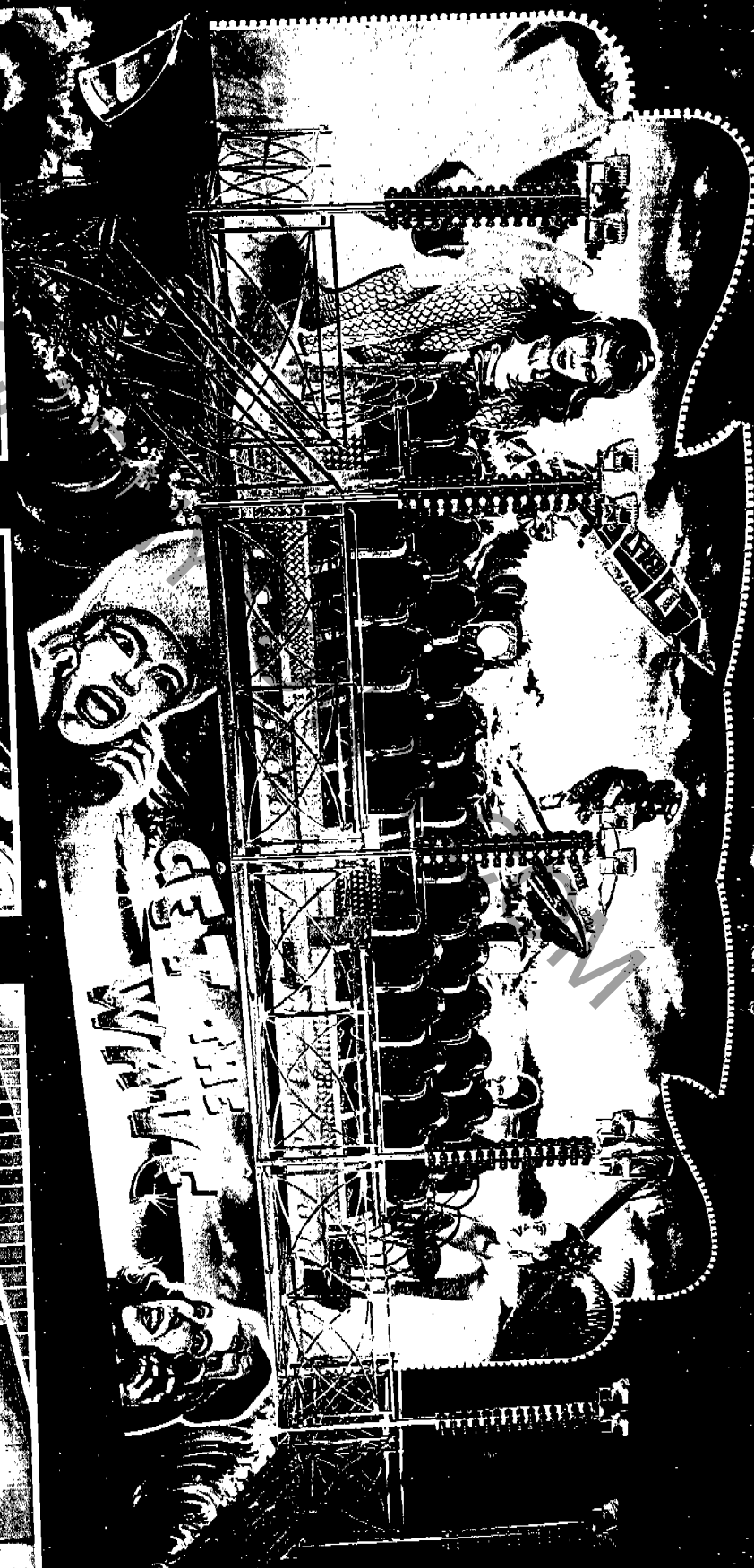

**GET THE
WAVE**

