

# Roller Coaster - Miler Schiff

MFG: SCHIFF  
NAME: ROLLER COASTER  
TYPE: NON-KIDDIE

## I. SETTING UP THE RIDE

### 1. Track, Track A-Frames, and Braces (See Drawing No. 22)

#### Sections No. 1 and No. 2 (Brake Sections)

These two Sections arrive assembled together and contain the Braking System, which has been assembled and adjusted at the factory. All of this should remain intact.

Use Saw Horses or similar supports, about 43" high, and set Sections 1 and 2 in place. Temporary Supports must contact only the bottom surfaces of the Track Sections and not touch any part of the operating mechanism. The Braking System, which is contained in these two Sections, has been adjusted at the factory. Do not loosen it during set up.

Place Support No. 17 (which is the extreme left Support) in place under the entrance end of Section 1. Bolt to Section 1 and remove enough of Temporary Support so that some weight rests on Support No. 17.

All Bolts throughout the Ride should be hand tightened until the entire Ride is assembled. Then wrench tighten for good alignment.

Place Support No. 1 in place beneath the Exit end of Section 1 and bolt in place. Install Brace No. 1 Inner and No. 1 Outer and bolt in place. Remove the Temporary Supports from under Section 1.

Install Support No. 2 in place beneath the Exit end of Section 2 and bolt in place. Install Braces No. 2 Inner and No. 2 Outer and bolt in place. Remove Temporary Supports from under Section 2.

### B. Section No. 3 (Start of Chain Section)

Support Section No. 3 temporarily, and install Bolts through Plates provided on Entrance end, bolting it to Section 2. Place Support No. 3 under Exit end of Section 3 and bolt in place. Install Braces No. 3 Inner and No. 3 Outer and bolt in place.

### C. Section No. 4 (2nd of Chain Section)

Engage slotted tabs at Entrance end of Section 4 with the 5/8" diameter stubs provided in Exit end of Section 3. Place Support No. 4 (which contains the Main Drive Assembly) in place under the Exit end of Section 4 and bolt in place. Install Braces No. 4 Inner and No. 4 Outer and bolt in place.

D. through O. Sections No. 5 through No. 16

Continue, repeating same procedure as used for Section 4 for Sections 5 through Section 17. Do not close the joint between Section 17 and Section 1 until after the Cars are installed because of the Safety Rollers on Cars.

Do not permanently attach the Supports ("A-Frames") to Base until after the Track is levelled as described in Part I.3.

## 2. Cars

When the Track installation is completed except for the joint between Sections 17 and 1, the Cars must be placed on the Track.

Place Car No. 1 (the Front Car) on Track Section No. 1 with the front end of the Car facing toward the inclined Motorized Section. The Safety Rollers of the Car must be under the top flanges of the Track as the Car is slipped on. Next slip Car No. 2 on the Track, front end forward behind Car No. 1. Next, Car No. 3, front end forward, behind Car No. 2, and so on with the Cars in ascending numerical order until all have been slipped on the Track. All Safety Rollers must be under the top flanges of the Track.

Install Loading Ramp, Pipes for the Canopy, or Planks which Molina has supplied, to provide a work platform. Then connect Cars together with the Hitch Bolts and Safety Chains provided.

Finish Track: Attach Exit end of Track Section No. 17 to Entrance end of Section No. 1 and bolt in place.

## 3. Levelling the Track

A Weld Bead is provided on the inward-facing side of each Track Support for use in leveling the Track. The Purchaser should set up a transit near the center of the oval-shaped space enclosed by the Track, and check the height of all the Weld Beads. If some are higher than others, Shims should be placed under Supports until all the Weld Beads are at the same level. Shims should be treated wood or corrosion-resistant metal.

When the Track is leveled and securely supported all around, attach Supports securely to Base. Tighten all Bolts throughout the Track, A-Frames (Supports) and Braces.

## 4. Chains

### A. Main Drive Chain

Install Chain Trough under Track Section No. 3 for Chain Return support.

The Main Drive Chain is then laid in place in Track Sections No. 3 and No. 4, on the Chain Guide Bar and over the Sprockets. Place Chain so that the widest part of the link is toward the highest end of the inclined Sections (Fig. 1). Arrange Chain so that the free ends are below the Track and near the lower Sprocket. C-Clamp the Chain to the Chain Guide above the lower sprocket. Pull the two ends together, insert the Pin through the end links, and place the Cotter Pin in the Pin. Chain should not be taut, for it will whip when in motion. There should be enough slack so that chain sags at both ends of the Chain Trough.

#### B. Small Drive Chain

Now assemble the 1" pitch (#80) Chain onto the Main Drive Sprocket and the large Sprocket on Track Section No. 4 (Fig. 1).

#### 5. Operating Rods for Clutch and Brake

There are two Operating Rods shipped with the Ride. The larger of the two, about 3/4" in diameter, is the Clutch Operating Rod. The other, about 1/2" in diameter, is the Brake Operating Rod. Do not change the adjustment of the Clevises at the ends of these Rods until after they are partially installed and their operation checked. They are usually set for proper operation at the Factory.

First, set the Operating Lever at about the center of travel (Fig. 1). Install the Clutch Operating Rod first, bent end toward the Clutch. Leave Cotter Pins out of Clevises until operation is checked. Move the Operating Lever toward the Left (Fig. 1). The Clutch should snap in when the Operating Lever is moved to the Third Notch from the end of the Ratchet in this direction.

If Clutch snaps in when the Lever is nearer the center position, unscrew Jam Nut for Clevis nearest Lever and turn Clevis to lengthen the Clutch Operating Rod. Lengthen the Rod a few turns at a time and try it. Continue this procedure until the Clutch snaps in at the Third Notch. Then tighten the Jam Nut securely and install the Cotter Pins in the Clevises of the Clutch Operating Rod.

If Clutch snaps in when the Lever is further from the center position than the Third Notch, or does not snap in at all, the Rod needs to be shortened. Loosen the Jam Nut at the Clevis nearest the Lever and follow the procedure outlined above except for shortening the Rod instead of lengthening it.

Now install the Brake Operating Rod, leaving out the Cotter Pins until the operation can be checked. Move the Operating Lever toward the Right (Fig. 1). The Brake Rail toward you should start moving away from you just after the Lever passes its center position of travel. If the Rail does not begin moving within 1-1/2 Notches of center position, the Brake Operating Rod needs to be shortened. Unscrew the Jam Nut at the Clevis on the Brake Operating Rod and nearest the Operating Lever. Shorten the Rod a few turns, then try the Rod. Continue this procedure until the Brake Rail begins to move just after the Operating Lever passes the center position of its travel.

If the Brake Rail begins to move when or before the Operating Lever reaches the center position of its travel, the Brake Operating Rod needs to be lengthened. Follow the same procedure as above except lengthen the Rod instead of shortening it.

After the Clutch Operating Rod and the Brake Operating Rod are installed, check the function of the Operating Lever. When the Lever is in the vertical (center) position the slot between the Braking Rails should be at its widest and the Clutch should be disengaged. As the Lever is moved toward the Right the Rails should start moving together. As the Lever is moved to the Left, the Clutch should engage when the Lever is moved to the Third Notch from the Left End of the Ratchet.

Summary: When the Operating Lever is Vertical, it is in a Neutral position. When it is moved toward the Right, it moves the Braking Rail to apply Brakes. When it is moved toward the Left far enough, it engages the Clutch.

#### 6. Brake Shoes

Install Brake Shoes on Cars No. 2, No. 3, and No. 4 as shown in Fig. 1. Use the 2" long, 5/8" diameter bolts provided and bolt securely in place. The markings on the Shoes should be observed and each Shoe mounted on the Car on which it belongs and with the correct side toward the Chassis of the Car. Brake Shoes should be installed so that the Shoe just touches the Stationary (Inner) Braking Rail. Use the Shim Washers provided to adjust Shoes. This avoids having some Shoes press too tightly against the Stationary Braking Rail.

#### 7. Electrical Connections

All Electrical Connections and interconnections are made by the Purchaser except for the Semi-Trailer mounted Ride. The interconnections are made by the Manufacturer on the Semi-Trailer Ride. These Rides are wired for the Wye System

as in Generators and should not be connected to a Delta System.

Before connecting power to the electrical motor, the Motor nameplate should be checked to be certain of the proper voltage and current required. The Motor should then be connected to a power supply having sufficient voltage and current capacity. Wiring should be large enough to avoid overheating and should be properly grounded, and otherwise conform to proper Safety practices. After the Motor is connected, check to see if it turns in the right direction. To do this, first put the Operating Lever in the Neutral Position, so that the Chain shall NOT move in the wrong direction. Then energize the Motor. The Large Sheave on the Clutch Shaft should turn in the Clockwise direction as viewed from the Front of the Ride. If it does not, reverse two of the electrical connections to the Motor.

#### 8. Initial Inspection

When all of the Ride appears to have been assembled and electrical connections made, inspect the Ride to be sure that it is safe to operate. See that all the Nuts and Bolts on the Track, A-Frames, and Braces are in place and tightened securely. Check to see that all Nuts, Bolts, Clevis Pins, and Cotter Pins in the Braking System are in place and properly secured. Do the same for the Main Drive Package. Make sure that Motor Belts and Drive Chains have the correct tension. Make sure all Cars are sitting securely on the Rails, and all Hitch Bolts in place and properly tightened. Check to assure that all Lap Bars are in place and securely attached, and all Safety Units and Safety Rollers turn freely by hand.

Check the width of the Track all around. The inner edges of the Rails should be 24" to 24 1/8" apart all around. Use a Puller or Jacks between the Rails to adjust this if it needs adjusting. This has been done already at the Factory; but the Track may have been slightly bent during unloading or assembly. Check Track for presence of any sticks or other loose objects. Remove any such objects from the surface of the Track and from between the Rails. The bottoms of the Cars extend down into the Track section and may collide with any foreign objects left in the Track Sections. No loose objects should be left near the Track.

Now the Ride should be started and the Cars run around the Track several times empty. See Part III. Do not "jerk" the Operating Lever to start Chain and Cars up the incline. It should be a smooth, slip clutch starting motion. The Main Drive Chain is very powerful and a sudden jerk on the Front Dog will cause breakage to Car and Chain alike. Any final adjustments which need to be made should be made at this point. The person who is to operate the Ride should

read Part III of this Manual and be operating the Ride during this initial trial run. He should start it and stop it and run it until he gets the "feel" of operating the Ride correctly now. As mentioned before, the Ride is not a "Push Button" type and a little practice and thorough study of Part III will more than pay for itself in Satisfaction, Less Down Time and Lower Maintenance Costs.

## II. SEMI-TRAILER MOUNTED RIDE

The Semi-Trailer mounted version of the Ride is supplied with Track Sections 1 through 4 assembled together, Chains and Cars installed and with the Operating Rods, Braking System, and Main Drive already adjusted. The Track Sections, A-Frames and Braces are stored in the "Possum Belly" of the Semi-Trailer, ready for use.

Track Sections Nos. 5 through 17 are set up in order as described in Part I.1, and shown on Drawing No. 22. There is no A-Frame No. 17, and A-Frames are not permanently attached to the Base, however. Use the Weld Beads on the A-Frames and set the Ride up level each time it is set up. The Semi-Trailer is leveled first and then the Track Sections installed and leveled up with it. The Track Width is checked each time the Ride is set up in accordance with Part I.8 and, if necessary, adjusted as described in Part I.8.

## III. OPERATING THE RIDE

This is not a Push Button Electrically Operated Ride. The function of the Ride depends on the Operator doing the right thing at the right time. However, it is easy if you learn two things: (1) The Dog on the Front Car should engage with the Drive Chain before starting the Ride. If it is not so engaged, push the Cars manually until it does engage. (2) When stopping the Cars, apply the Brakes smoothly and stop the Ride so that the Dog on the Front Car engages the Main Drive Chain in about the fourth link above the bottom Sprocket.

Practice with the Ride empty will enable you to find out how hard to Brake to stop the Ride with the Front Dog engaged. Chain stays in motion until Cars go up the incline for the last trip around. At this time, move the Operating Lever to the Neutral Position to be able to "feel" for the Brake.

Always watch to be sure the Track is clear of all sticks, rocks, tools, etc., before starting the Cars moving. Also be sure nobody is too close to the Ride before starting Cars to move.

Turn Electrical Power Off while loading and unloading passengers for safety.

When passengers are getting on the Ride, always load them about two to a car if they came together, being sure there is space enough for them to sit flat on the seat. Then pull the Lap Bar down close to their laps and engage the Lap Bar Latch in one of the holes provided, to hold the Lap Bar securely in place. Show passengers how to hold onto the Upper Rail of the Lap Bar and onto the sides of the Car. Tell them to hold on tightly. Instruct all passengers not to stick their heads or their arms over the sides of the Cars. Keep all arms and heads inside the Cars. When stopping the Ride, be sure no passengers try to get out before the Ride is fully stopped, the Power is Off, and you have unlatched and raised the Lap Bars for them. Do not load more weight than one child and one large adult in any one Car. The Car is not supposed to carry more than 350 lbs.

When the Ride is loaded, a little harder Braking will be required than when it is empty. Practice first with the seats empty until you can stop the Ride with the Front Dog engaged in about the fourth Chain Link past the bottom Sprocket every time. Then watch the Ride while you are stopping it like this, to get a feel for how fast it has to slow down to stop at the right place. Now when you operate the Ride with people in it, try to make it slow down in the same way and stop with the Front Dog engaged. A little practice may be required to stop it right every time with different sized loads. Remember, it must always slow down at the same Rate to stop at the same Place, regardless of load. Keep practicing and watch the rate at which the Ride slows down to help you recognize the right rate of slowing down. Remember, a loaded Ride requires a little harder Braking--but not a lot harder.

#### IV. REGULAR INSPECTION AND MAINTENANCE

##### 1. Regular Inspection

Before each day's operation, go all the way around the Track. Be sure all connections are secure on Track, A-Frames, and Braces. See that all Nuts are secure and all Latch Pin Clips are in place. Be sure Track, A-Frames, and Braces are not bent and are cleared of all objects which are not a part of the Ride. Be especially certain there is nothing on the Track or in the Track Sections. If Cars collide with such objects, severe damage or injury could result. All A-Frames must be checked to see that they are resting firmly and securely on their Bases. This is especially true of the Semi-Trailer Mounted Ride. Look at the Cars to be sure that all Hitches are fastened securely and all Safety Chains are in place. Check Bolts on Wheels and Safety Rollers to be sure they are secure. Look at Wheels and Car Chassis for cracks. Look at Wheels for any signs of Bearing Failure, such as unusual flow of grease, or one

the lubricant also to the Clevises on the Clutch Operating Rod and the Brake Operating Rod and to the linkage in the Braking System. Do not put grease or oil near the Braking Surfaces of the Braking Rails or the Brake Shoes.

An oil can with a spout should be used to sparingly apply medium grade, non-detergent oil to the working surfaces of the Hitches and the Safety Units. The outside of these items does not need to be oily. A drop of oil should occasionally be put on each pivot Rod and Latch for the Lap Bars. Wipe off any excess immediately to avoid possibly soiling clothes of persons using the Ride afterwards. This lubricant should also be applied in the same way to the Ratchet surfaces and adjacent linkages on the Operating Lever.

If Motor needs lubrication, follow Motor Manufacturer's Instructions.

Grease Wheels and Safety Rollers weekly, using the Alemite fittings provided. Wipe off any grease which comes out of these as you go, to avoid having excess grease on the Tracks and rolling surfaces. Also use the Alemite fittings on the Shaft of the Operating Lever, Pivot Rod and Shifter Ring in the Clutch linkage and on several Pillow Blocks to grease these items weekly. Take especial care when greasing the Clutch Shifter Ring not to get grease where it can get on the Clutch Friction Lining. The Pillow Blocks are located near both Sprockets for the Main Drive Chain and on the Clutch Shaft in the Main Drive. Always wipe off the excess grease with a wiping cloth or bundle of waste immediately after you grease each fitting.

The Lap Bars and the Fiberglass portions of the Cars should be kept clean with a clean cloth and a proper solvent.

### 3. Clutch

The Clutch is a type which snaps to engage. It should snap in when the Operating Lever is moved toward the Left to the Third Notch from the Left Hand end of the Ratchet. If the Clutch does not snap in when the Lever is moved to this position, it should be adjusted. If the Clutch snaps in within about 1/2 Notch of this, the adjustment should be made by changing the effective length of the 1/2" diameter threaded rod about 8" long which is near the Clutch Shifter Yoke (see Clutch Parts List). Loosen the Jam Nuts and turn the Clevises to lengthen the Rod if the Clutch is snapping in too late. If it is snapping in too early, the Rod needs to be shortened. If larger adjustments are required, the Clutch Operating Rod which runs from the Operating Lever to the Main Drive should be adjusted. The Clevises on this Rod are taken loose and this Rod shortened if the Clutch snaps in too late. This needs to be lengthened if the Clutch snaps in too early.

If the Clutch is snapping in at the right time but is failing to engage, or slipping too much, an adjustment to the Clutch itself is needed. As you read these Instructions, you need to look at the Parts List for the Clutch and at the Clutch on the Ride. Disengage the Clutch and see if there seems to be grease on the Friction Linings. If this is not the trouble, try adjusting the Clutch. First, loosen the Cap Screw on the Adjuster Assembly. Turn the Adjuster Assembly 1/2 turn Clockwise and engage the Clutch. If the Clutch is difficult to engage, it is set too tight for the cup-shaped cam to slide easily over the Adjuster Levers. Turn the Adjuster Assembly Counterclockwise until the Cam will snap over the Levers without too much difficulty. If slippage still occurs, there is probably grease on the Friction Lining or the Friction Lining is worn out. Normally, if the Clutch is set too tight it is difficult to engage, and if it is set too loose it slips. Turning the Adjuster Assembly Clockwise tightens the Clutch; turning it Counterclockwise loosens the Clutch. If it cannot be set to a point where it engages easily and does not slip, the Friction Lining is probably oily or worn out and needs to be replaced.

To replace the Friction Lining, disengage the Clutch, loosen the Cap Screw on the Adjuster Assembly, and turn it Counterclockwise until there is enough clearance between components to permit removal of each of the three segments that make up the Lining. Insert new segments and fasten as required. Turn Adjuster Assembly Clockwise until it appears to be in operating position, and proceed with adjustment as outlined above.

#### 4. Dog Installation

There are four Dogs on the Ride. There is one on the front of the Front Car and one on the rear of the Front Car. There is one on the rear of Car No. 3 and one on the rear of Car No. 5.

The proper positioning of the Dogs should be checked with the Ride on the Incline and the Power Off. The Front Dog on the Front Car should be in contact with a roller in a Link of the Main Drive Chain. The Rear Dog on the Front Car should be 1/8" ahead of the nearest Chain Link roller. The Dog on Car No. 3 should be 1/4" ahead of the nearest Chain Link roller, and the Dog on Car No. 5 should be 3/8" ahead of the nearest Chain Link roller.

#### V. WARRANTY

This Moli-Coaster (formerly known as the Schiff Roller Coaster) is guaranteed against defects in material and workmanship for

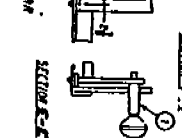
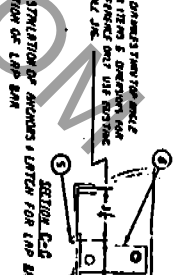
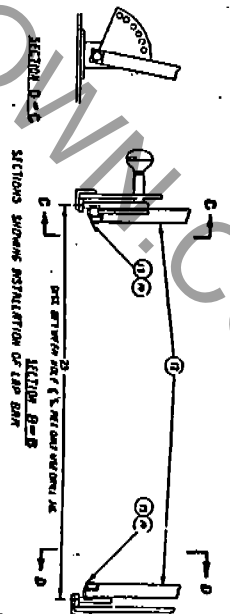
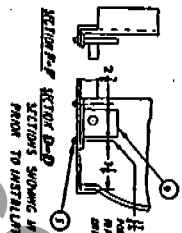
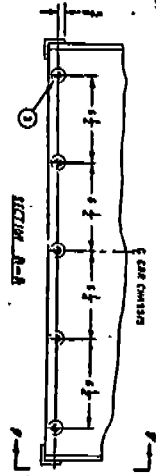
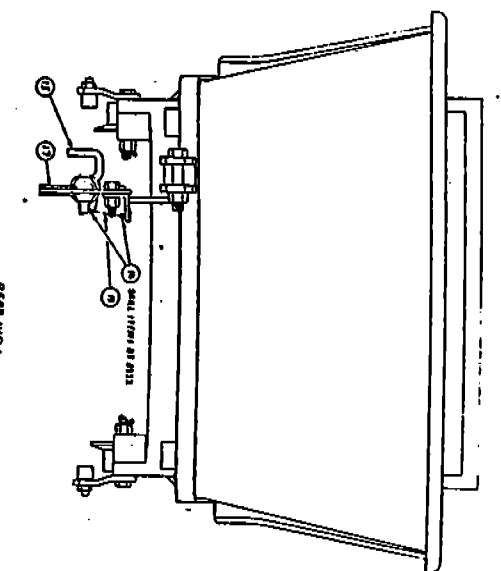
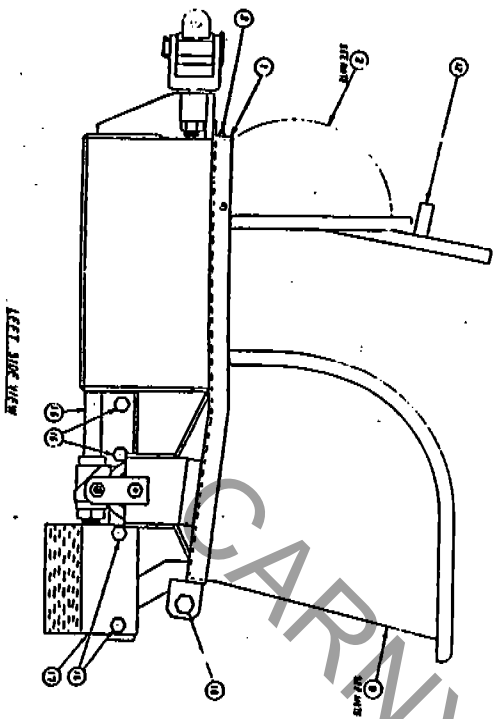
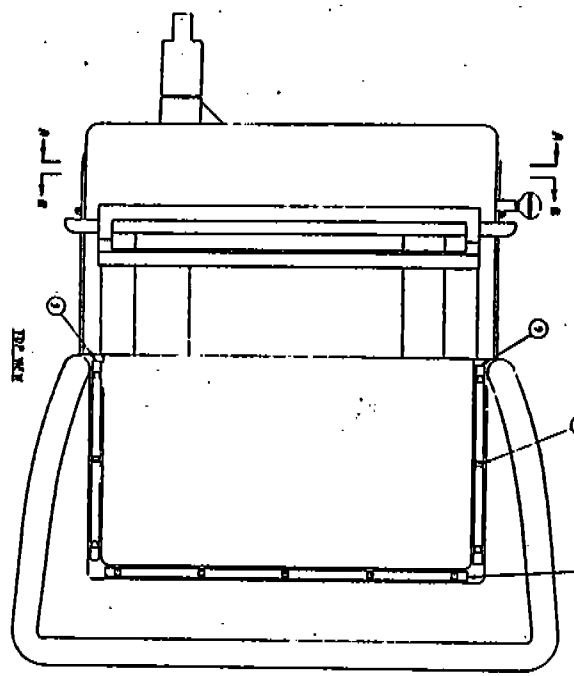

SECTION B-B  
SECTIONS SHOWING INSTALLATION OF SPRING & LATCH FOR LAP BAR

SECTION C-C  
SECTIONS SHOWING INSTALLATION OF LAP BAR

SECTION D-D  
SECTIONS SHOWING INSTALLATION OF LAP BAR

SECTION E-E  
SECTIONS SHOWING INSTALLATION OF LAP BAR

BILL OF MATERIALS	
ITEM NO.	DESCRIPTION
1	1 CAR CHASSIS ASSEMBLY
2	1 FRONT SECTION FRAME
3	1 REAR SECTION FRAME
4	1 LAP BAR
5	1 SPRING
6	1 LATCH
7	1 PIVOT
8	1 BUSHING
9	1 WASHER
10	1 NUT
11	1 SCREW
12	1 BRACKET
13	1 PLATE
14	1 ROLLER
15	1 WHEEL
16	1 AXLE
17	1 HOUSING

NOTE: ITEM 111, OR EQUIVALENT, IS REQUIRED FOR THE LAP BAR AND SPRING. SEE DRAWING FOR PARTS LIST AND DIMENSIONS. SEE DRAWING FOR PARTS LIST AND DIMENSIONS. SEE DRAWING FOR PARTS LIST AND DIMENSIONS.

BILL OF MATERIALS	
ITEM NO.	DESCRIPTION
1	1 CAR CHASSIS ASSEMBLY
2	1 FRONT SECTION FRAME
3	1 REAR SECTION FRAME
4	1 LAP BAR
5	1 SPRING
6	1 LATCH
7	1 PIVOT
8	1 BUSHING
9	1 WASHER
10	1 NUT
11	1 SCREW
12	1 BRACKET
13	1 PLATE
14	1 ROLLER
15	1 WHEEL
16	1 AXLE
17	1 HOUSING

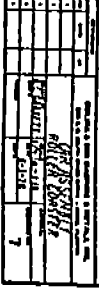

NOTE: ITEM 111, OR EQUIVALENT, IS REQUIRED FOR THE LAP BAR AND SPRING. SEE DRAWING FOR PARTS LIST AND DIMENSIONS. SEE DRAWING FOR PARTS LIST AND DIMENSIONS. SEE DRAWING FOR PARTS LIST AND DIMENSIONS.

