

**SAC SARTORI** s.r.l.

COSTRUZIONI ATTREZZATURE PER PARCHI DIVERTIMENTO

MFG: SARTORI  
RIDE: BALLOON WHEEL

*(Sviluppo Amusement)*

# BALLOON WHEEL 8

CARNY TOWN.COM

MOD. RS/142

USE AND MAINTENANCE MANUAL BOOK



## **IMPORTANT**

**WE REMIND YOU THAT FOR SAFETY REASONS THE ATTRACTION MUST BE SET UP BY QUALIFIED PERSONNEL, AND THE ELECTRIC CONNECTIONS MUST BE MADE BY QUALIFIED AND AUTHORIZED PERSONNEL.**

**WE REMIND THAT EACH MODIFICATION IN THE TECHNICAL FEATURES OR EVENTUAL TAMPERINGS OF THE ATTRACTION NOT PROVIDED BY THE MANUFACTURER ARE THE MAKER'S RESPONSIBILITY.**

**THE ATTRACTION HAS NOT BEEN PLANNED FOR HANDICAPPED CHILDREN OR OTHER PERSONS.**

CAROLINYTOWN.COM

## GENERAL INDEX

- 1) INTRODUCTION
- 2) SAFETY RULES
- 3) GENERAL TECHNICAL INFORMATION
- 4) DRAWING RIDE TYPE "BALLOON WHEEL 8"
- 5) ORDINARY MAINTENANCE
- 6) DRAWING GENERAL BOARD AND CONTROL BOARD
- 7) OPERATION
- 8) ELECTRIC PLAN
- 9) LIST OF ELECTRIC COMPONENTS
- 10) HYDRAULIC INSTALLATION PLAN
- 11) LIST OF HYDRAULIC INSTALLATION COMPONENTS
- 12) HYDRAULIC CONTROL BOX
- 13) CONTROLS FOR LIFTING OF COLUMN AND STABILIZER
- 14) BRAKING INSTALLATION PLAN
- 15) LIST OF BRAKING INSTALLATION COMPONENTS
- 16) PLAN OF PNEUMATIC SUSPENSION INSTALLATION
- 17) LIST OF COMPONENTS OF THE PNEUMATIC SUSPENSION INSTALLATION
- 18) WHAT TO DO IF.....

## INTRODUCTION

The use and maintenance manual book is a useful guide for the operator to get a correct operation of the attraction.

This manual contains all rules that the operator must follow before, during and after each use of the attraction for his own safety and riders' safety.

This manual must always be with the ride and the operator must read it carefully before setting up and starting the ride. If some parts of the manual are not clear, please contact our technicians for any explanation.

The ride must only be started by adult (over 18) personnel aware of its features and of its particular safety procedures.

Each arbitrary modification to the ride excludes our Company from any responsibility for possible damages to things or people.

MYTOWN.COM

## SAFETY RULES

### ASSEMBLING / DISMANTLING

Before assembling / dismantling the ride the operator/s must be aware of the following safety rules. He must remember that an improper use of the attraction and the inobservance of any of the safety rules can cause serious damages to people and to the structures of the ride.

Our Company obliges the operator to observe the following rules :

- Before setting up the ride make sure that the fixed area is sufficiently large and has no high tension wires, trees or any object that could be dangerous for the set up and the operation of the ride.
- During assembling or dismantling non-authorized personnel may not be in the work area.
- Assembling and dismantling must be made by qualified personnel.
- Take care to hanging loads and before making any movement, make sure that each load is properly fastened to cranes and manoeuvring machines.

### OPERATION

As concern the safety rules to be followed during operation of the ride, our Company provides the following instructions and restrictions :

- Personnel encharged to operate the ride must be adult (over 18) and qualified and must be aware of the contents of this manual book.
- Before opening the ride to the public, the operator will have to make the attraction ride empty for some minutes and check if **START-STOP-EMERGENCY** controls are properly working.
- In no case may the operator leave unattended the control board inside the ticket booth while the ride is working. He must be replaced by qualified personnel.
- The operator must let the riders take place only on cars with working safety gates, and make sure that everybody is properly sitting.
- Before starting make sure that nobody is inside the safety fences or come close to the working area of the ride and inform riders by a sound signal that the ride is beginning.
- If during operation a rider tries to get on or get off the moving cars, stop immediately the ride by the **EMERGENCY** button.

## CHECKINGS BEFORE STARTING

Before starting the ride make some important checkings.

- Always before any use check the perfect levelling of the ride by the stabilizers on the trailer. In order to make this operation easier, you can find close to the axles an up / down valve to level the trailer by lifting it. While the ride is working the trailer is in down position (pict. 1).

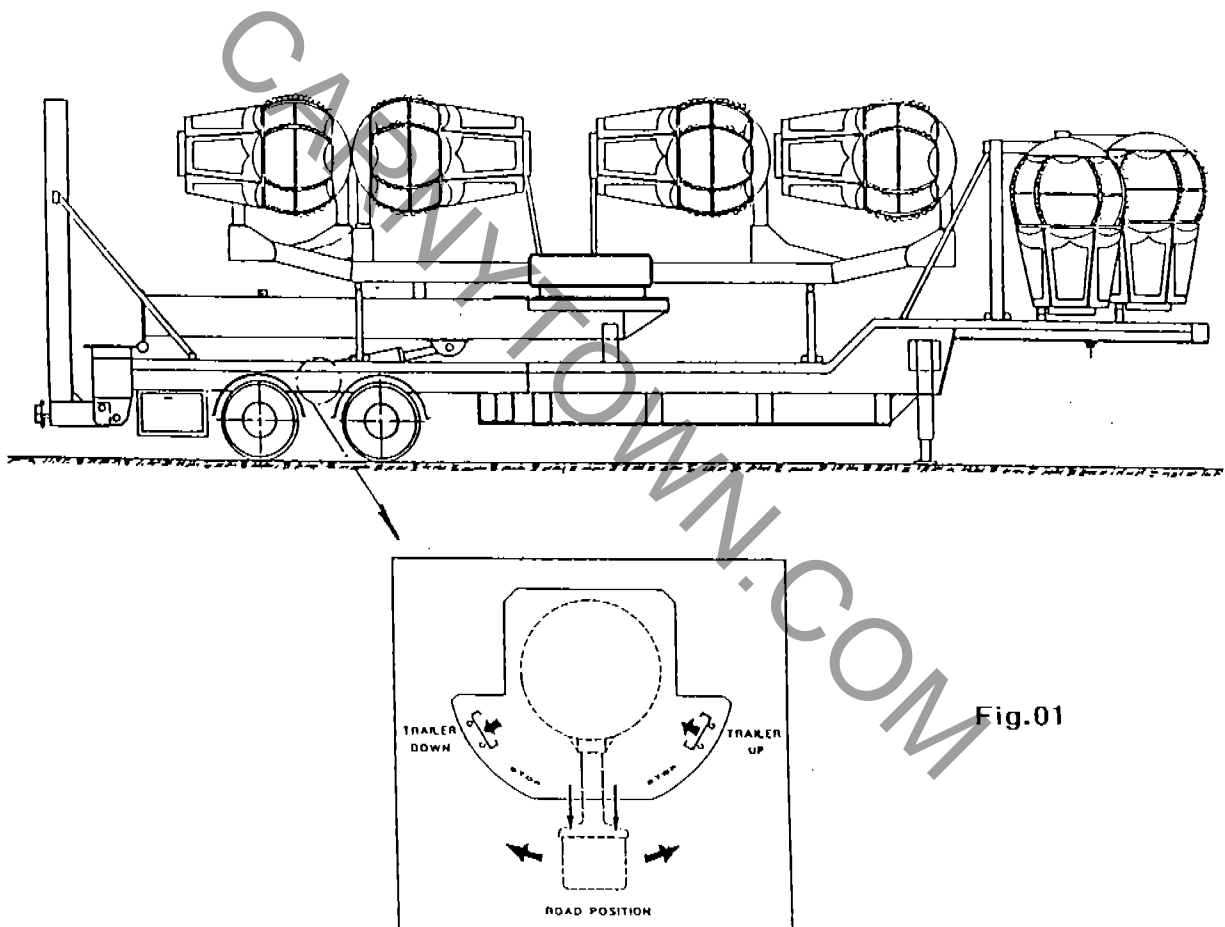

Fig.01

- Before using the ride check if the grounding is properly connected. Do not give power to the electric board if you do not need. The grounding connection must be made by qualified personnel and must follow the rules in force.
- We recommend to check all operation and safety devices. If a device does not work let riders go on to the ride only after repairing it.

- Check if all plugs of the electric installation are properly connected.
- Check if all pins are properly introduced and have their own safety split pins.
- Before opening the ride to the public check the fixing of the screws of the column to the reference plate on the trailer (pict. 2), the fixing of the screws of the arms to the ride structure (pict. 4), the fixing of the screws in the joints of the folding arms (pict. 3), the fixing of the cars to the arm connection (pict. 5).

**NOTE :** For any connection use the proper screws supplied with the ride and for their fixing use the proper spanners.

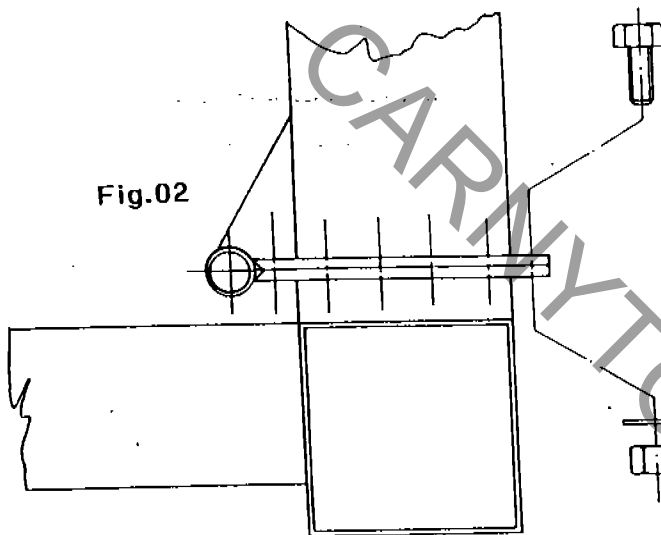

Fig.02

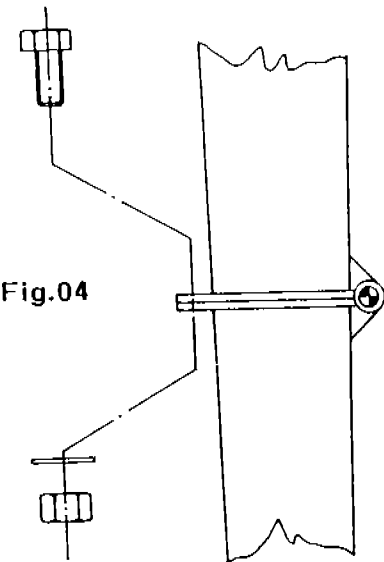

Fig.04

Fig.03

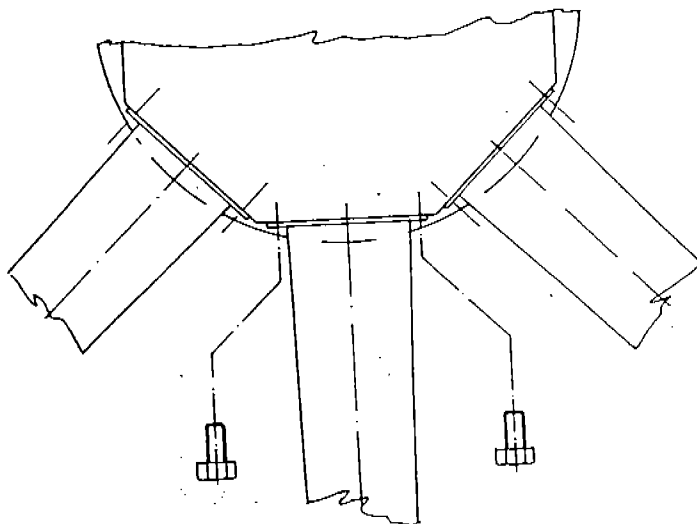
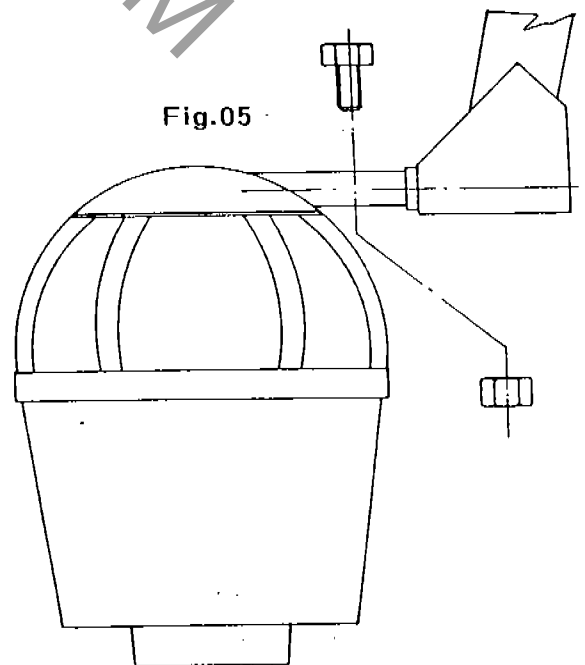

Fig.05



## GENERAL TECHNICAL INFORMATION

MOVING POWER	Kw 15
LIGHTING	Kw 11
MOVING POWER TENSION	220V / 380V triphase
LIGHTING TENSION	220V / 110V monophas
FREQUENCY	50 / 60 Hz
ROTATION SPEED	3 R.P.M.
CARS	8
CAPACITY	32 RIDERS
SIZES IN OPERATION	mts 9,15 x 18,8 x 10H
WEIGHT	kg. 20.400
TRANSMISSION	HYDRAULIC

#### 4) DRAWING RIDE TYPE "BALLOON WHEEL 8"

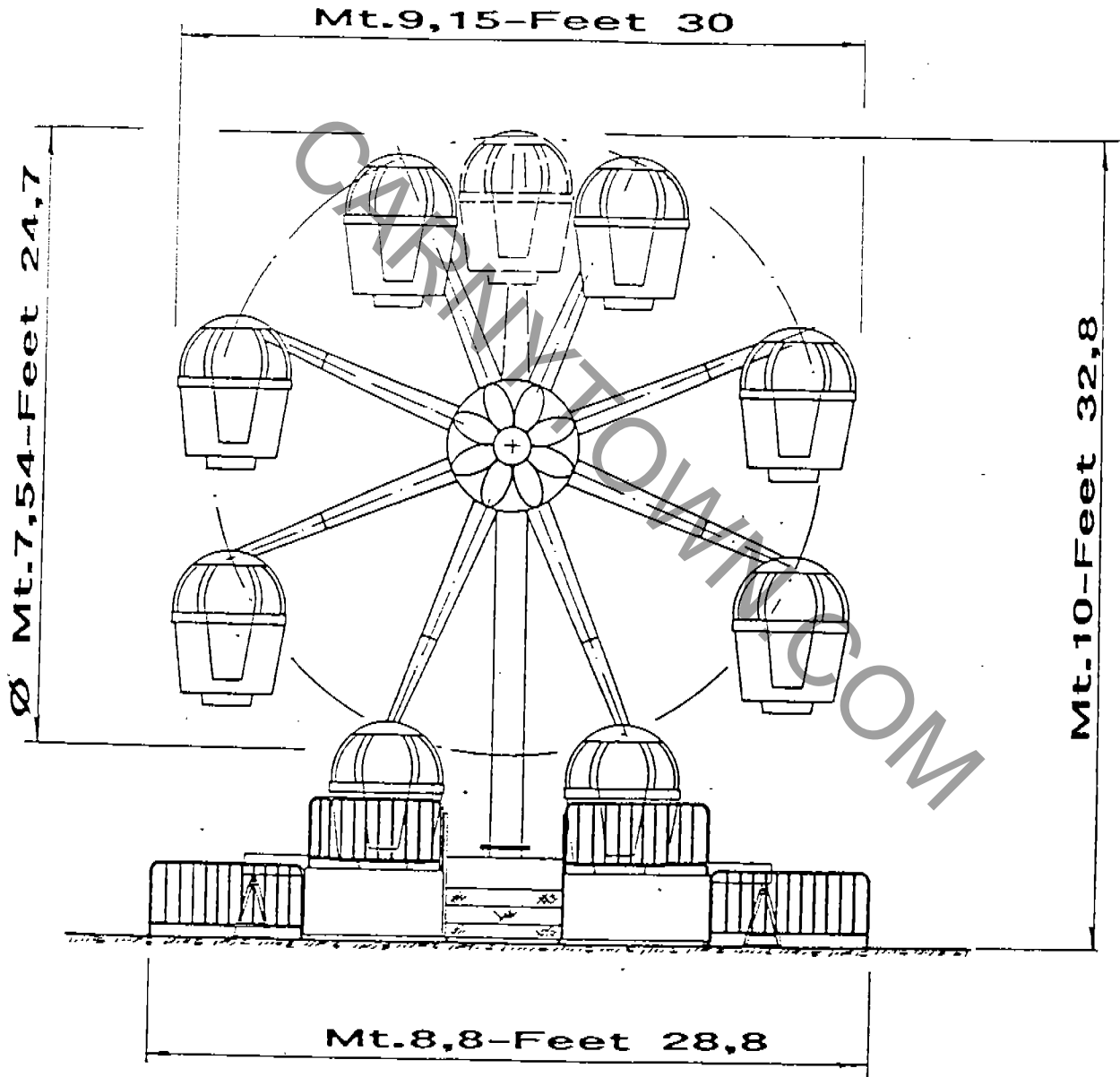

Width mts 2,5 - Feet 8,2

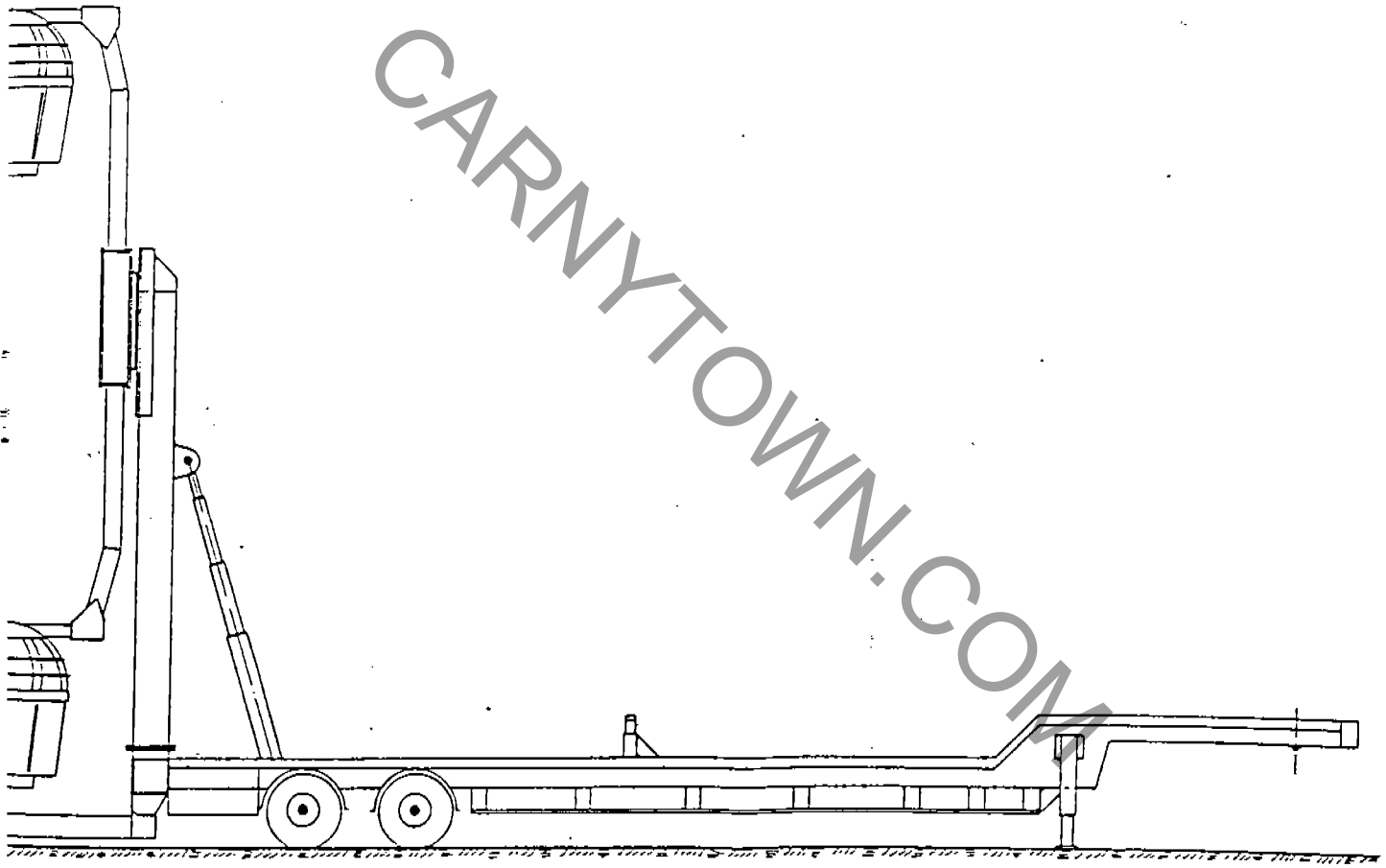

Mt. 18,8 - Feet 61,7

## ORDINARY MAINTENANCE

The operator must carefully follow all maintenance operations of the ride, in order to get a proper working with the lowest costs.

Please follow the down mentioned program for a normal use of the ride.

### DAILY MAINTENANCE

Check if all pins have their own safety split pins, add if failing.

Check the right connection of the electric plugs.

Check if the supporting stabilizers rest properly on the ground (pict. 6).

Check if the safety gates on each car properly work, otherwise do not use the damaged cars.

Before starting check the perfect operation of the **START-STOP-EMERGENCY** devices.

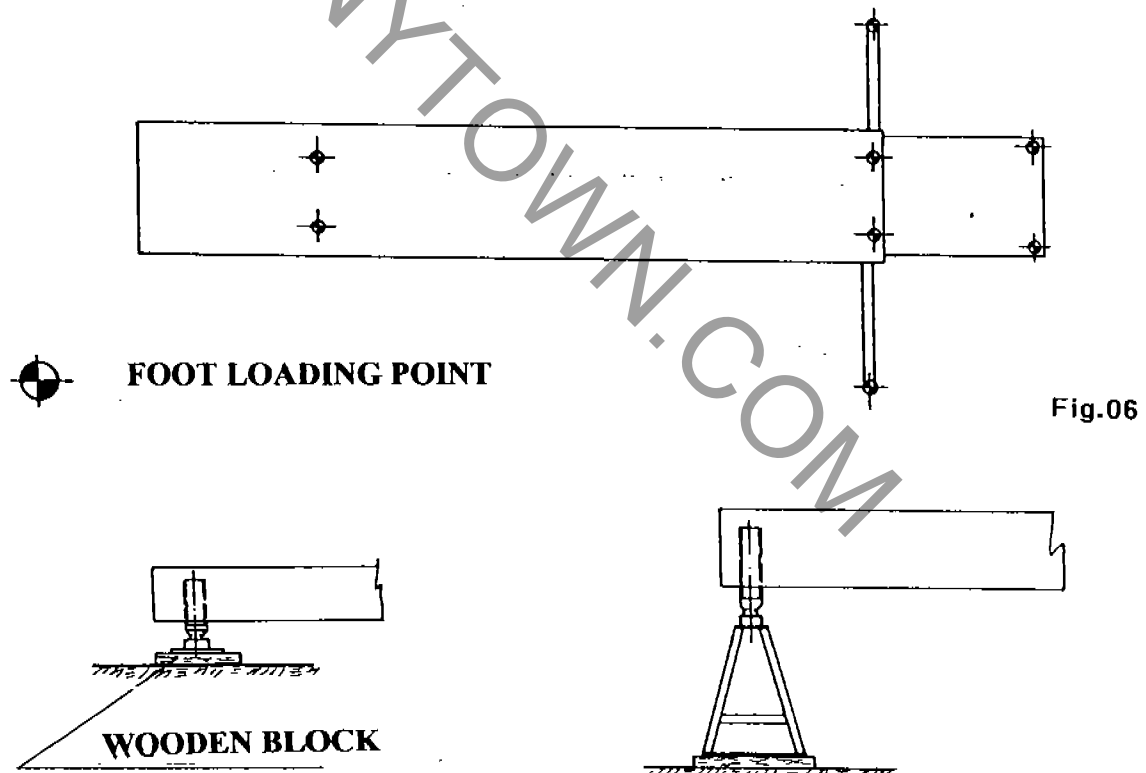

### PERIODICAL MAINTENANCE

Please take care to greasing operations which have the purpose to reduce friction, make tight and protect from wear and tear the various mechanical parts of the attraction.

We recommend to grease to sprocket bearing of the transmission by the greasers on the column (pict. 7) so that the grease flows out of the labyrinths of the bearing and of the seals.

Grease the exterior sprockets of the gears (pict. 8).

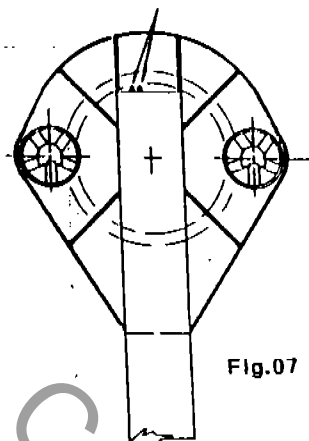

Fig.07

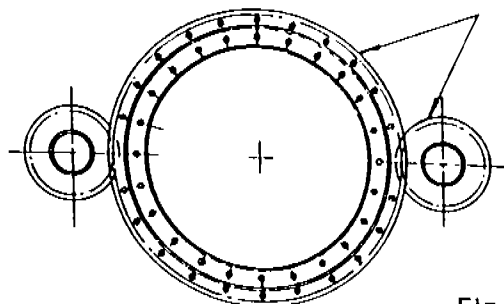

Fig.08

Grease by the proper greasers the bearings of the car-holder connection on the arms (pict. 9).

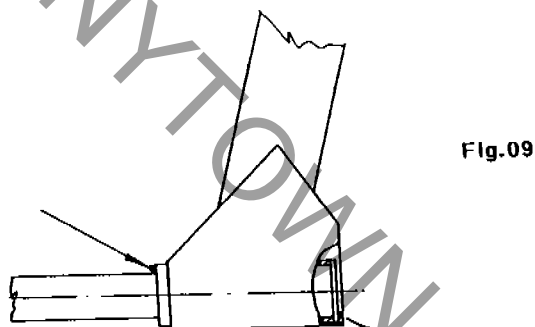

Fig.09

Grease by the proper greasers the pins of the eyelets of the lifting cylinder of the column and the two lifting cylinders of the back stabilizer (pict. 10).

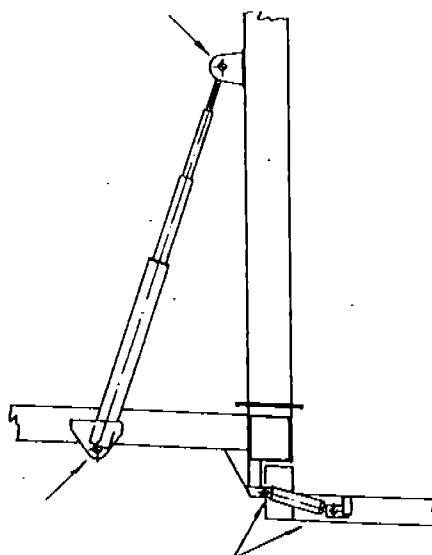

Fig.10

Grease also the rotation hinge of the column and the rotation pin of the back stabilizer by the proper greaser (pict. 11).

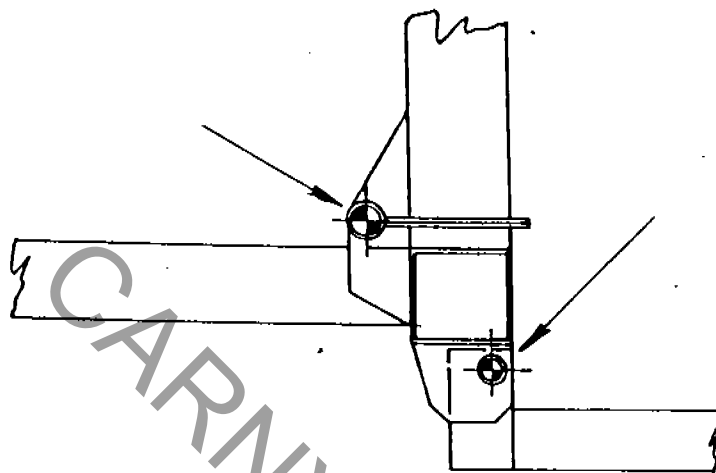

Fig.11

Clean by compressed air the central collector inside the ride and the collector on each arm (pict. 12).

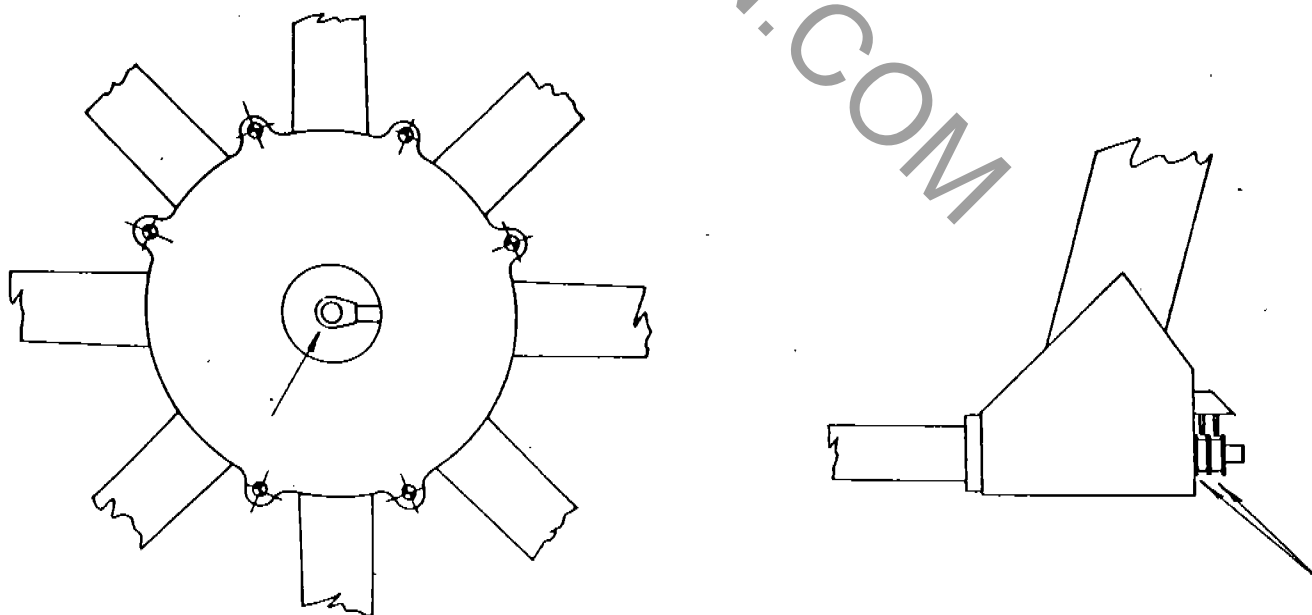

Fig.12

Maintenance of the hydraulic installation is very important, it refers to the hydraulic motors, the hydraulic control box, the cylinder for the lifting of the column and the cylinders for the lifting of the back stabilizer.

The operations to make are the check of tightness of all joints, in case of oil leaks, replace the joint or the pipe.

Monthly check oil level in the tank on the trailer, if needed add oil AGIP OSO 68 or OSO 100 or oils with the same temperature and viscosity range as the types in the table hereafter.

We recommend to change oil the first time after 50-100 working hours and then after 2500 hours or at least once every 12 months.

We recommend to avoid to mix oils of different type and anyway synthetic with mineral oils.

**NOTE : If more than 10% of oil fails check if there are leaks.**

FIRM	For a normal use at environment temperature from - 5°to +40° Viscosity ISO VG68 (DIN 51519)		For a difficult use at environment temperature from +30°to +50° Viscosity ISO VG100 (DIN 51519)	
	H-L (DIN 51524)	H-LP (DIN 51525)	H-L (DIN 51524)	H-LP (DIN 51525)
	AERO-LINE STAR (Prinz-Schulte KG)	AERO-LINE H 68	AERO-LINE Torqmatic Fluid 5	AERO-LINE H 100
AGIP	SIC 68	OSO 68	SIC 100	OSO 100
ARAL	VITAM UF 68	VITAM GF 68	VITAM UF 100	VITAM GF 100
AVIA	AVIALUB Hydr.-OI RL 68	AVILUB Hydr.-OI RSL 68	AVILUB Hydr.-OI RL 100	AVILUB Hydr.-OI RSL 100
BP	BP Energol RC 68	BP Energol HLP 68	BP Energol RC 100	BP Energol HLP 100
BRENNTAG	Hydraulikol F	Turboid F	Hydraulikol H	Turboid H
CALYPSOL	Hydraulikol HLP 68	Hydraulikol HLP 68	Hydraulikol HLP 100	Hydraulikol HLP 100
CASTROL	HYSPIN VG 68	HYSPIN AWS 68	HYSPIN VG 100	HYSPIN AWS 100
CHEMFA	CHEMFOL GP 68	CHEMFOL GP 68	CHEMFOL GP 100	CHEMFOL GP 100
CHEVRON	HYDRAULIC OIL 68	EP HYDRAULIC OIL 68	HYDRAULIC OIL 100	EP HYDRAULIC OIL 100
CONDOR	HYDOR 68	CONDORANT EMK	HYDOR 100	CONDORANT EMO
ECUBSOL Wenzel & Weldmann	Hydraulikol H-L 68 ECUBSOL OEL RK 68	Hydraulikol H-LP 68 ECUBSOL OEL HYM	Hydraulikol H-L 100 ECUBSOL OEL RK 100	Hydraulikol H-LP 100 ECUBSOL OEL HYS
ELF UNION	ELF POLYTELIS 68	ELF ACANTIS 68	ELF POLYTELIS 100	ELF ACANTIS 100
ESSO	ESSTIC 68	ELF OLNA 68 NUTO H 68	ESSTIC 100	ELF OLNA 100 NUTO H 100
FINA	FINA CIRKAN 68	FINA HYDRAN 68	FINA CIRKAN 100	FINA HYDRAN 100
FUCHS	RENOLIN B 20	RENOLIN B 20	RENOLIN B 30	RENOLIN B 30
GULF	RENOLIN MR 20 HARMONY 68	RENOLIN MR 20 HARMONY 68 AW	RENOLIN MR 30 HARMONY 100	RENOLIN MR 30 HARMONY 100 AW
KLUBER LUBRICATION	CRUCOLAN 68	LAMORA HLP 68	CRUCOLAN 100	LAMORA HLP 100
MARTIN	LIGOMAR 68 MZK	LIGOMAR 47 EP	LIGOMAR 100 MZK	LIGOMAR 64 EP
MIHAG	CD 68	HS 68	CD 100	HS 100
MOBIL	MOBIL D.T.E. OIL HEAVY MEDIUM	MOBIL D.T.E. 26	MOBIL D.T.E. OIL HEAVY	MOBIL D.T.E. 27
MOBIL-ALLOY	MA-OI 604-H-LP mit Festschmierstoffen	MA-OI 604-H-LP mit Festschmierstoffen	MA-OI 605-H-LP mit Festschmierstoffen	MOBIL D.T.E. 18
OEST	OEST Hydraulikol H-L 68	OEST Hydraulikol H-LP 68	OEST Hydraulikol H-L 100	MA-OI 605-H-LP mit Festschmierstoffen OEST Hydraulikol H-LP 100
OPTIMOL	Optimol Hydo 5065 VG 68	Optimol Hydo 5065 VG 68	Optimol Hydo 5095 VG 100	OEST Hydraulikol H-LP 100
SHELL	Optimol HydoMV5065VG68 SHELL TELLUS OEL C68	Optimol HydoMV5065VG68 SHELL TELLUS OEL 68	SHELL TELLUS OEL C100	Optimol Hydo 5095 VG 100
SUN OIL C*	SUNVIS 931 (ISO 68)	SUNVIS 831 (ISO 68)	SUNVIS 951	SHELL TELLUS OEL 100
TEXACO	RANDO OIL 68	RANDO OIL HD C 68 RANDO OIL HD CZ 68	RANDO OIL 100	SUNVIS 851
TOTAL	TOTAL REO 68	TOTAL AZOLLA 68	TOTAL REO 100	RANDO OIL HD E 100
VEEDOL	ANDARIN 55	ANDARIN 55	ANDARIN 60	TOTAL AZOLLA 100
WISURA	DYNEX 68	WISURA TEMPO 68 WISURA HYDROMA 68 ZG HLP 68 ZG DHG 68	DYNEX 100	ANDARIN 60
ZELLER+GMELIN	ZG GWA 3 ISO 68		ZG GWA 4 ISO 100	WISURA TEMPO 100 WISURA HYDROMA 100 ZG HLP 100 ZG DHG 100

The check of the electric installation is limited to the connections of male / female plugs remembering that each verification must be made by qualified personnel and with no power in the ride.

We recommend not to change the electric installation and to replace damaged pieces with proper material.

The braking and pneumatic suspension installation do not require a special maintenance but only some checks before each travel.

Check the perfect working of the brakes and of the stop lights.

Check tyre pressure and the fixing of the nuts of the rims and check if the position of the up / down valve for the suspensions is in its correct central road position.

CARNYTOWN.COM

6) DRAWING GENERAL BOARD AND CONTROL BOARD

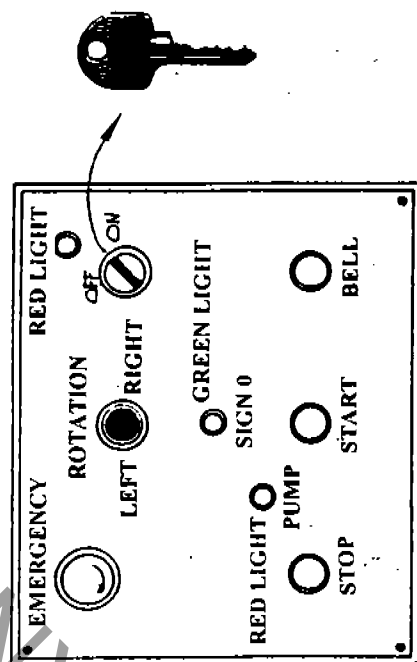
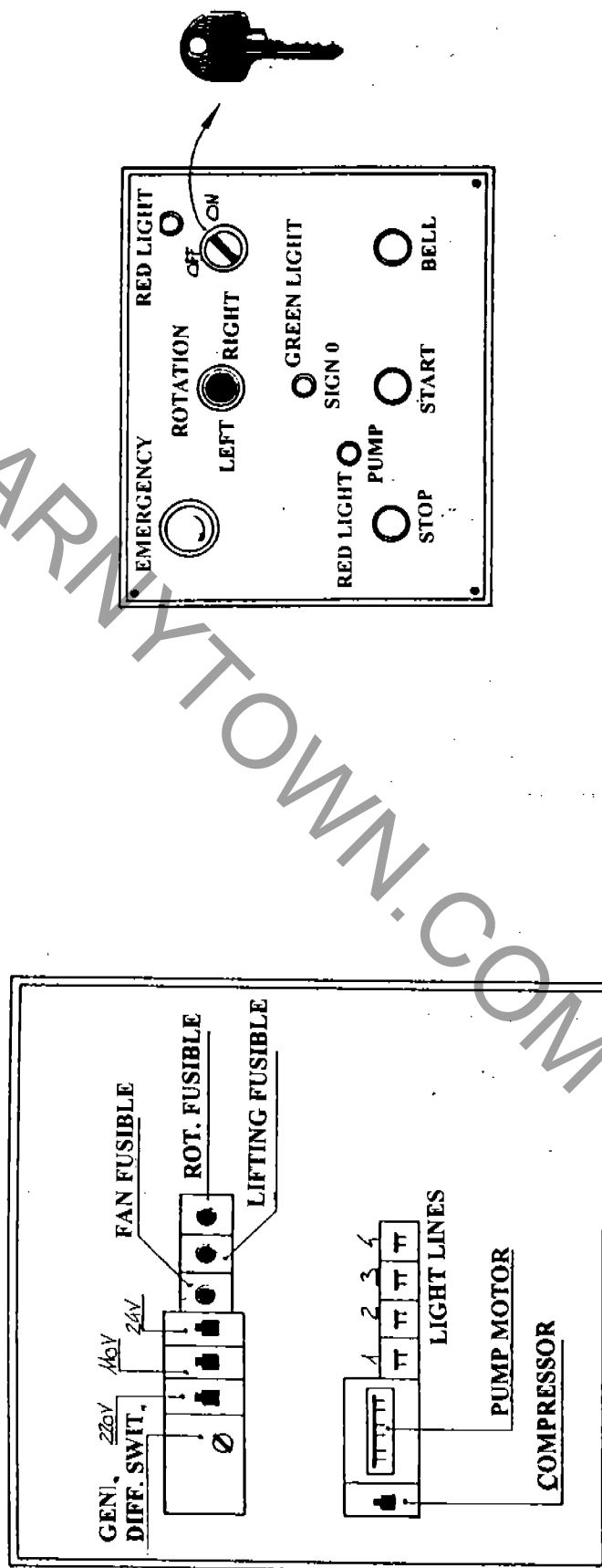

## OPERATION

In order to better understand please refer to the drawing of the general board and control board.

Switch on the general differential switch, the control switches 220V, 110V and 24V the suitable line switches and the pump motor switch.

To start the ride use the rotation controls lever by the switch with key taking it to "ON" position and with the corresponding red light switched on.

Take the rotation lever to the left or to the right in order to find the zero of the hydraulic control box (the green light in the middle of the control board lights up).

Now push the START button in order to start the pump motor. Before starting the rotation, push the BELL button to inform riders that the ride is going to begin, then make the attraction ride taking the rotation lever to the right or left according to the wished rotation sense.

Keeping the lever in the same position as the wished rotation sense, you reach the highest rotation speed.

To stop the rotation take the same lever to the direction opposite to the rotation sense until the green light on the control board lights up.

**Do not use the STOP button to stop the rotation of the ride.**

**NOTE : For any anomalies or strange behaviour of a rider, push the red EMERGENCY button and the ride will stop immediately.**

**The operator must verify how to go on assuring the maximum safety to the riders.**

When lifting or lowering the column or the back stabilizer, disconnect the rotation lever by the proper switch with key, taking it to "OFF" position. This device is useful to avoid an accidental start of the rotation of the ride during set up and dismantling operations which can be dangerous for the encharged personnel.

In the electric board there is a switch which starts the service compressor for the fixing of the screws of the various joints or to make the suspensions lift when the tractor fails.

# 8) ELECTRIC PLAN

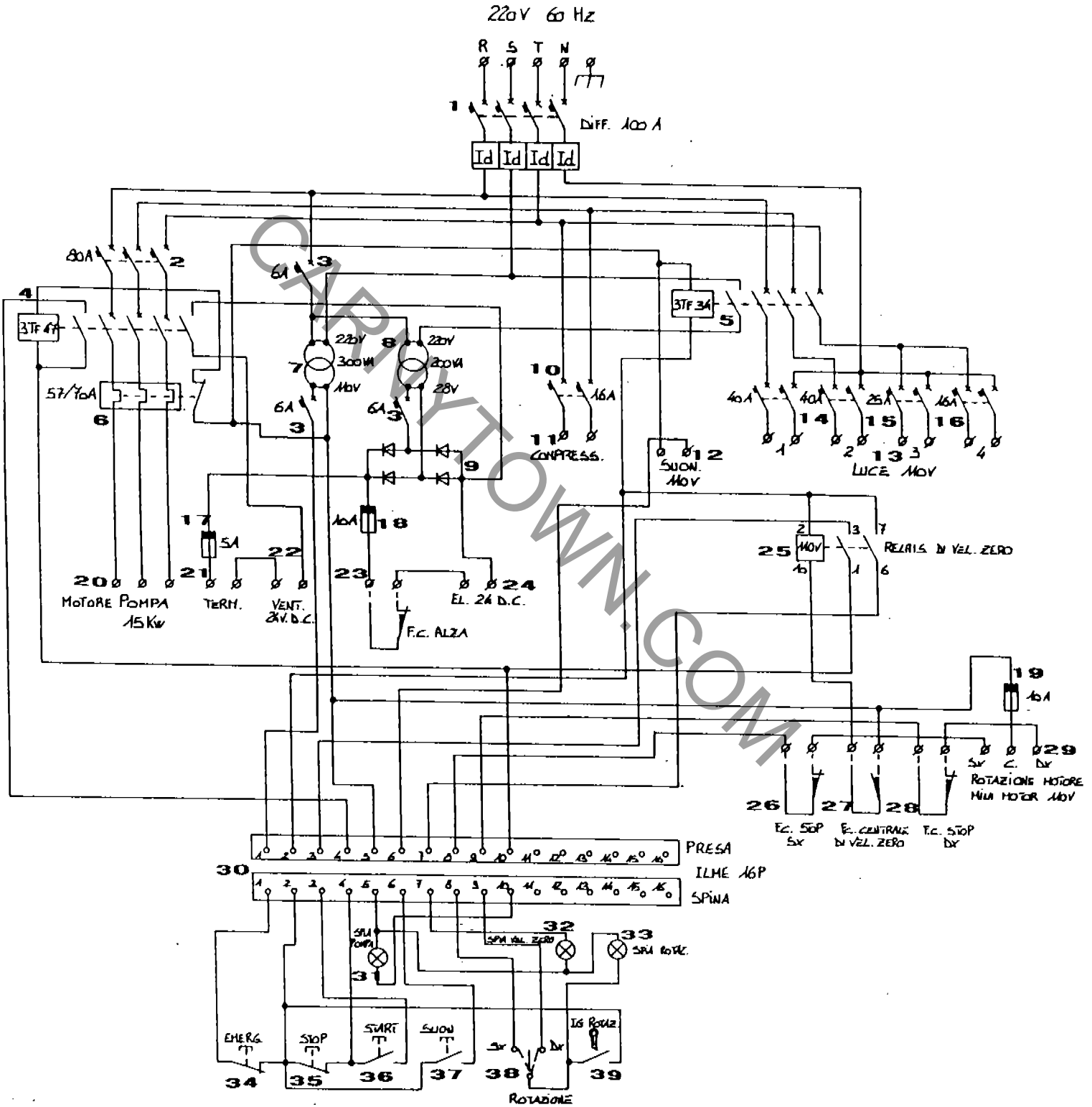

## LIST OF ELECTRIC COMPONENTS

- 1) Differential switch Siemens 100A
- 2) Tripolar magnetothermic switch Siemens 80A
- 3) Unipolar magnetothermic switch Siemens 6A
- 4) Contactor Siemens 3TF47
- 5) Contactor Siemens 3TF34
- 6) Thermic contact of contactor pos.4
- 7) Transformer/rectifier 220V/110V 300VA
- 8) Electrovalve transformer 220V/28V 200VA
- 9) Rectifier 24 D.C. electrovalve supply
- 10) Bipolar magnetothermic switch Siemens 16A
- 11) Terminals for 220V auxiliary compressor supply
- 12) Terminals for 110V bell supply
- 13) Terminals for 110V light supply
- 14) Bipolar magnetothermic switch Siemens 40A
- 15) Bipolar magnetothermic switch Siemens 25A
- 16) Bipolar magnetothermic switch Siemens 16A
- 17) Fusible 5A oil radiator thermostat protection
- 18) Fusible 10A protection of limit-switch for lifting
- 19) Fusible 10A protection of minimotor-reducer
- 20) Pump-motor terminal box
- 21) Terminal box of oil radiator thermostat

- 22) Terminal box of oil radiator fan
- 23) Terminal box of limit switch for lifting
- 24) Terminal box of 24 V D.C. electrovalve supply
- 25) Elesta relais 110V undecal
- 26) Terminal box F.c. STOP left
- 27) Terminal box F.c. central 0 speed
- 28) Terminal box F.c. STOP right
- 29) Terminal box of 110V minimotor-reducer supply
- 30) Male / female plug ILME 16P
- 31) Light of pump motor working
- 32) Zero speed light
- 33) Light of connected /disconnected rotation lever
- 34) EMERGENCY button
- 35) STOP button
- 36) START button
- 37) BELL button
- 38) Manual lever for right and left speed regulation
- 39) 38 lever excluder key switch

# 10) HYDRAULIC INSTALLATION PLAN

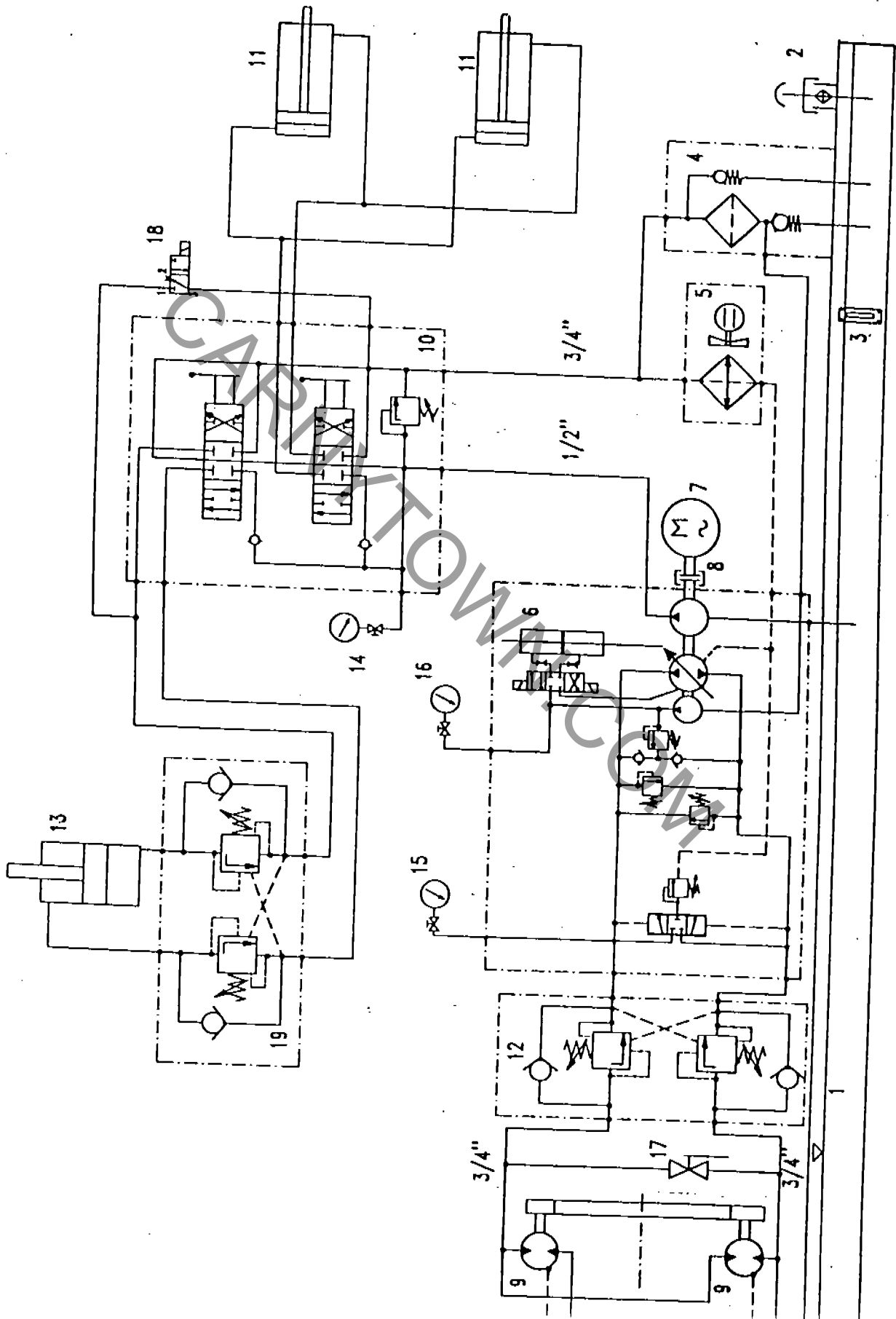

## LIST OF HYDRAULIC INSTALLATION COMPONENTS

- 1) Hydraulic oil tank capacity 200 lts
- 2) Oil filling up / vent plug
- 3) Oil level
- 4) Combined filter
- 5) Air oil heat exchanger
- 6) Pistons + gears pump
- 7) Electric motor
- 8) Joint + elastic joint
- 9) Hydraulic motor
- 10) Manual distributor
- 11) Cylinder lifting back stabilizer
- 12) Valve of descent stop and control
- 13) Column lifting cylinder
- 14) Manometer + excluder
- 15) Manometer + excluder
- 16) Manometer + excluder
- 17) Ball-cock
- 18) Electrovalve
- 19) Valve of descent control and stop
- 20) Valve of descent control

## 12) HYDRAULIC CONTROL BOX

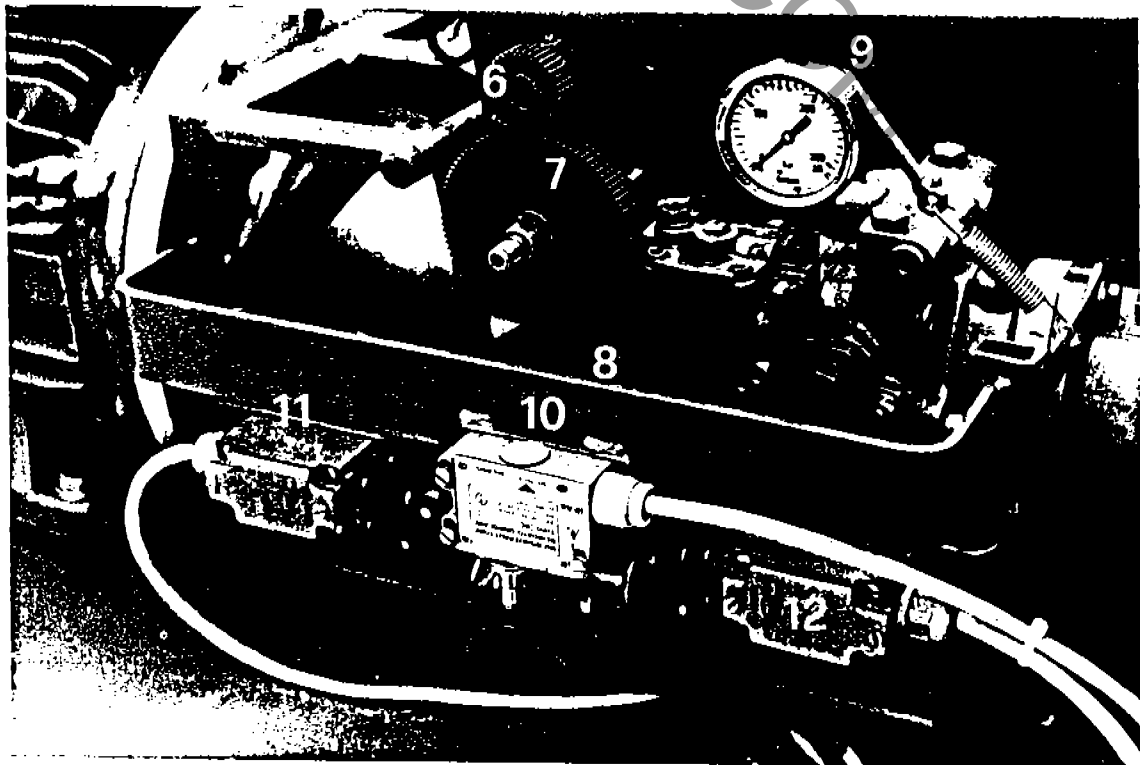
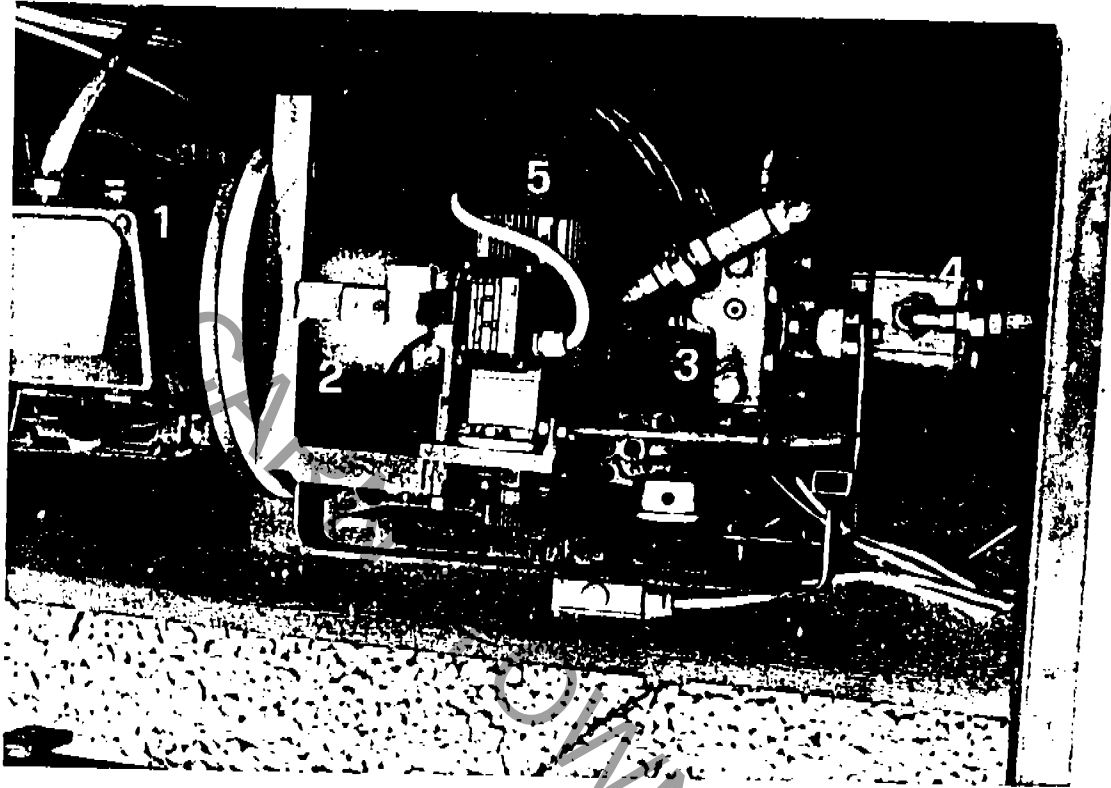

## LIST OF HYDRAULIC CONTROL BOX

- 1) Electric motor "Leroy Somer" HP20 B3-B5 380V 50Hz
- 2) Joint + elastic joint "HYDR-APP" HLC9 + GB42-Z15.16/32
- 3) Pistons pump "HP" M4PV 50-50 I221.3BVR
- 4) Gear pump "VIVOIL" KV2P 14D d=82,5 SAE
- 5) Minimotoreducer "Minimotor" ACE 40 B5 i=920,5
- 6) Minimotoreducer pinion Z=38
- 7) Satellite gear Z=80
- 8) Half-moon gear Z=125
- 9) Manometer "FT" Diam. 63 0...320bar + FT290.01
- 10) Limit switch "Electrica" speed 0 BC 7AZP
- 11) Limit switch "CEMA" Stop left 114FCB11F
- 12) Limit switch "CEMA" Stop right 114FCB11F

13) CONTROLS FOR LIFTING OF COLUMN AND STABILIZER

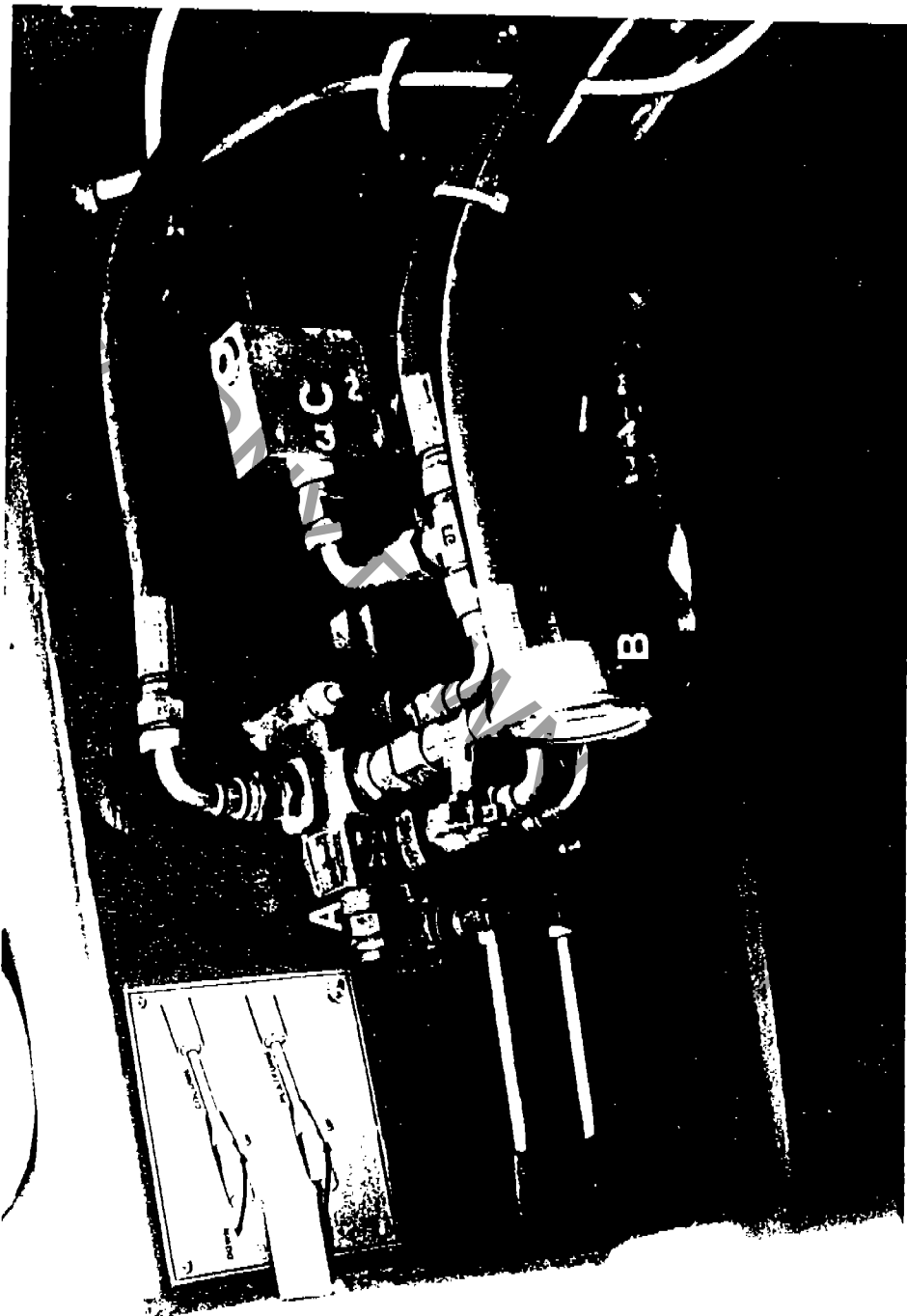

## LIST OF CONTROLS FOR COLUMN AND STABILIZER LIFTING

- A Manual distributor with "Galtec" levers  
PL 25M2.F7S(N) 2 x 103A1M1 F3D
- B Manometer "FT" Diam. 63.0....100 bar FT 290.01
- C Electrovalve "Delta" 3V.-2P.NC.24V DC-3/8"-S2A.1

CARNYTOWN.COM



## LIST OF BRAKING INSTALLATION COMPONENTS

- A ISO red joint (automatic)
- B ISO yellow joint (adjustable)
- C Servoautodistributor
- D Braking release cock
- G Brake chamber 16" with yoke
- H Condensation drain valve
- K Handle emergency brake
- L Steel tank 75 lt. (D=360 x 866)
- M ABS MODAL 4S/2K
  - ABS Modal control box
  - ABS Modal relay (2 outputs M22 x 1,5)
  - Electrovalve yellow cable 6m.
  - Electrovalve blu cable 6 m.
  - Sensor yellow cable 6 m. 2B
  - Sensor yellow cable 6 m. 3B
  - Sensor blu cable 6 m. 2A
  - Sensor blue cable 6 m. 3A
  - Green light
  - Lamp support
  - Bulb 24V 5W
  - Cable ABS Modal 12 m. ISO 7638
  - Cable for joint 24N Modal
- 1 Straight fitting M16 x 1,5 T12 with spring

- 2 Straight fitting M16 x 1,5 T12
- 3 3 way banjo union T12 M22 x 1,5 T12
- Pressure test connection fM 18 x 1,5
- Copper washer Di=10
- 4 Straight fitting M22 x 1,5 T20
- 4' 3 way banjo union T20 M22 x 1,5 T20
- 6 Cranks banjo union M22 x 1,5 T20
- 7 3 way banjo union T12 M22 x 1,5 T12
- 9 Straight fitting M22 x 1,5 T12
- 10 Cranks banjo union M16 x 1,5 T12
- 11 Cranks banjo union M22 x 1,5 T12
- 12 Pressure test connection M16 x 1,5
- 14 3 way fitting M16 x 1,5 T12 for joints
- 17 3 way banjo union T12 M16 x 1,5 T12
- Pressure test connection fM 18 x 1,5
- Copper washer Di=10
- Reinforcement bush Di=8
- Reinforcement bush Di=12
- Reinforcement bush Di=16
- Copper washer Di=16
- Copper washer Di=22

# 16) PLAN OF PNEUMATIC SUSPENSION INSTALLATION

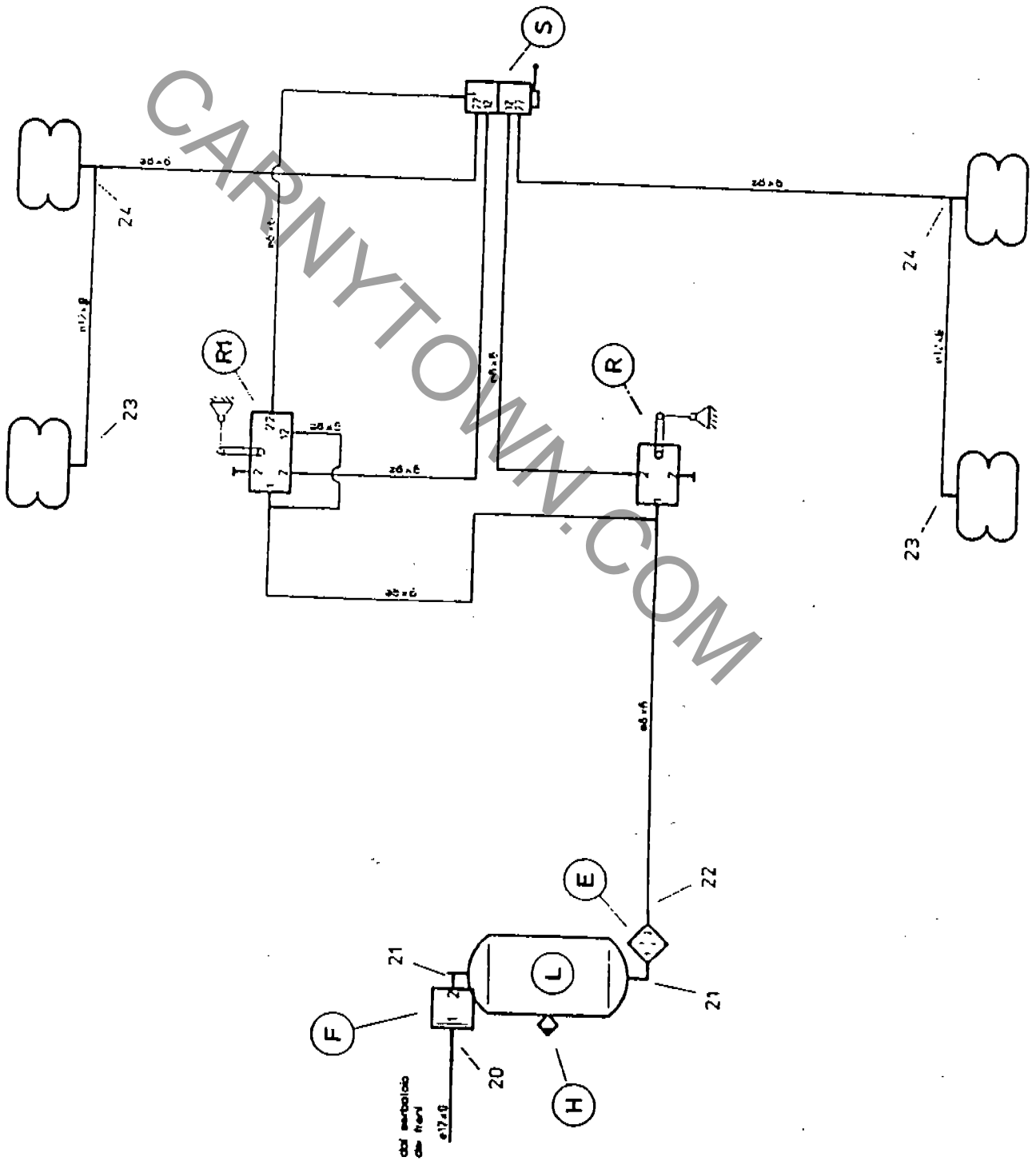

## LIST OF COMPONENTS OF THE PNEUMATIC SUSPENSION INSTALLATION

- E Line filter
- F Pressure valve 4,2 bar
- H Condensation drain valve
- l Steel tank 75 lt. (D=360 x 866)
- R Leveller with larger pipe
  - Adjustable tie-rod for leveller L=259
  - Plug M12 x 1,5
  - Straight fitting M12 x 1,5 T8
  - 3 way banjo union T8 M12 x 1,5 T8
- R1 Leveller with limit switch with larger pipe
  - Adjustable tie-rod for leveller L=259
  - 3 way banjo union T8 M12 x 1,5 T8
  - Plug M12 x 1,5
  - Straight fitting m16 x 1,5 T8
- S Up / down valve 2 sections
  - Cranks banjo union M16 x 1,5 T8
- 20 Straight fitting M22 x 1,5 T12
- 21 Cranks banjo union M22 x 1,5
- 22 Straight fitting m22 x 1,5 T8
- 23 Cranks banjo fitting M22 x 1,5 T12
- 24 3 way banjo union T12 M22 x 1,5 T12

- Smooth straight fitting 12 T8
- Aluminium washer  $D_i=22$
- Aluminium washer  $D_i=16$
- Aluminium washer  $D_i=12$
- Reinforcement bush for  $D_i=6$  and  $D_i=8$

CARNYTOWN.COM

## WHAT TO DO IF....

### THE ATTRACTION DOES NOT RESPOND TO THE CONTROLS

Check in the general board all fusibles, replace them if damaged.

### LIGHTS DO NOT WORK

Check the fusibles in the lights control box, check the lights out and replace the damaged ones. We remind that in each car there is a fusible which controls the electric installation of the car. Therefore, if only the lights of the car do not work, check the fusible on the top of the car (pict. 14) or the brushes of the collectors in the arms.

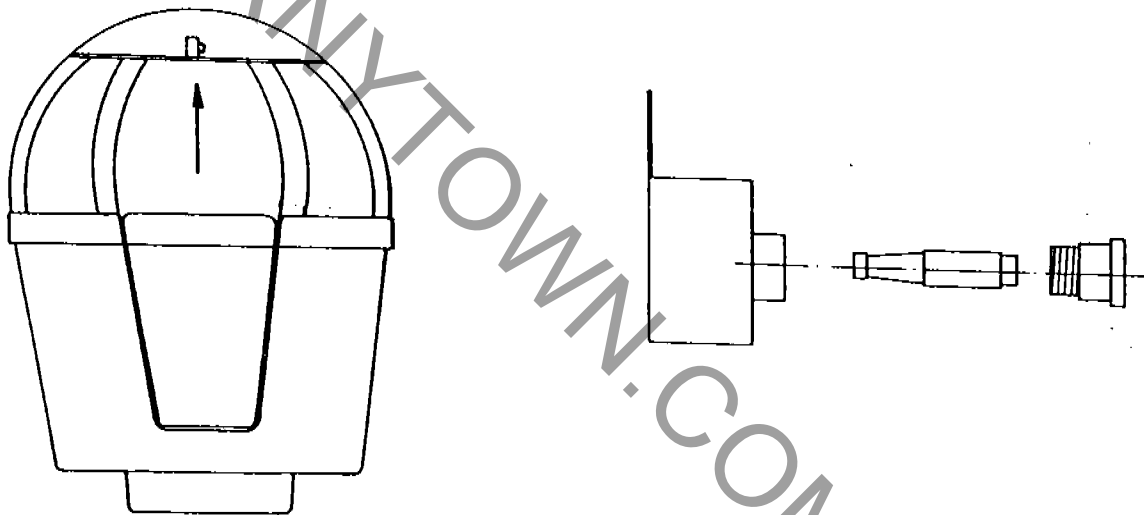

### POWER FAILS, THE ATTRACTION STOPS

In this case, the first operation is to assure the maximum safety to the riders, then release the two hydraulic motors by a lever on one side of the bearing column and take each car to riders loading / unloading position.

After this operation, check the fusibles in the general board, replace them if needed. If the problem does not depend on the fusibles, please contact our technicians.

### ROTATION DOES NOT STOP USING THE PROPER LEVER

Check the limit switches of the hydraulic control box, replace them if needed.

### THE SAFETY GATE OF A CAR DOES NOT WORK

For riders safety replace the gates immediately; if it is not possible, do not use the damaged car.

## **THE COLUMN AND STABILIZER LIFTING DEVICE DOES NOT WORK**

Check the integrity of the fusibles in the general board, then check limit switches for column and stabilizer lifting.

## **THE AUXILIARY COMPRESSOR JAMS**

In case of a heavy use the auxiliary compressor may jam because of the overheating. We recommend to wait some minutes and let the compressor get cool, then start it by the button placed as in the picture.

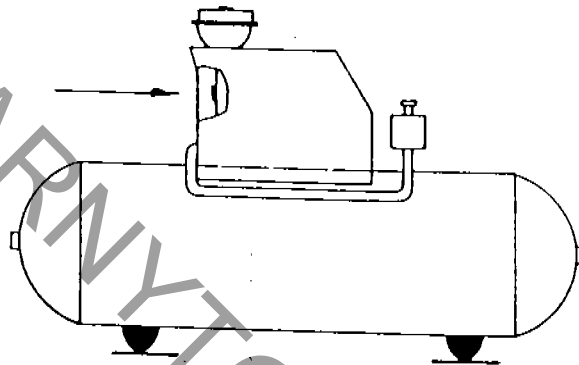

**FOR POSSIBLE PROBLEMS WHICH DO NOT FIND A SOLUTION IN THIS MANUAL BOOK, PLEASE CONTACT OUR COMPANY, OUR TECHICIANS WILL BE AT YOUR COMPLETE DISPOSAL.**