

MFG: MCGUFFY  
NAME: OSCAR AND THE WHALE  
TYPE: KIDDIE

OPERATION MANUAL

OSCAR AND THE WHALES

CARNYTOWN.COM

Manufactured by:

McGuffey Manufacturing  
1514 30th Street  
Parkersburg, WV 26101

(304) 375-7625

OPERATION MANUAL

OSCAR AND THE WHALES

- 1.0 This Operation Manual establishes the operating and maintenance procedures for this amusement ride in accordance with the requirements of ASTM F770-88 and F853-86.
- 2.0 The purpose of this Operation Manual is to describe the operating and maintenance procedures necessary to properly operate and maintain this amusement ride.

CARNY TOWN.COM

### 3.0 OPERATION:

3.1.1. The following is a description of the ride including the function and operation of its major components.

Oscar and the Whales is a kiddie ride consisting of 8 whales and an octopus center.

3.1.1.1. Description of the motion of the ride during operation.

The ride is operated in a counter-clock-wise motion with four hills and valleys.

3.1.1.2. Description of the recommended passenger loading procedures during operation, including recommended seating, where applicable.

The preferred order of loading is to load sweep no. 1, no. 4, no. 6, no. 7, no. 2, no. 3, no. 8, and finally, no. 5. If two children are seated in a whale, the larger child should sit on the outside of the whale.

3.1.2. Recommended safety procedure and instructions, and information about safety equipment pertaining to patrons and ride operators and attendants.

All passengers must be restrained. At no time shall a passenger be allowed to stand while the ride is in operation. All parts of his body, especially arms and hands, should be inside the whale and on the hand rail. All persons, except passengers and operators, shall be outside the enclosed area with gates closed and latched. The operator must keep a close watch on the patrons at all times. The ride attendant must hold the dead-man switch with a part of his body.

3.1.2.1. Maximum total passenger weight and maximum number of passengers by carrier unit or ride total.

There should be a maximum of two passengers per car with a maximum weight of 60 pounds per car.

3.1.2.2. Description of the passenger restraint system, its recommended use and operation.

Each passenger must be restrained with a safety belt placed over the lap of the child and tightened.

3.1.2.3. Ride or device operator and attendant safety check: recommended visual or other inspections to be performed by ride operators and attendants prior to and during each ride cycle.

Per OABA ride safety checklist.

3.1.2.4. Instructions to the patron: recommended information that should be made available to each patron of the ride.

Safety guidelines are to be posted by this ride advising that there is an inherent risk in using or riding an amusement device. The patron must inform himself of the warnings and obey them if he/she decides to participate. Participation is at your own risk. The safety guidelines listed in 3.1.2 shall be posted plus any additional ones at the discretion of the owner.

3.1.2.5 Recommendations for operational restriction relating to environmental conditions such as wind, rain, or temperature fluctuation.

The ride cannot be operated in heavy rains, or strong winds. In case of flood, do not let the whales swim away.

3.1.3. Manufacturer's recommended ride operating procedures, including the location of ride operators and attendants.

The operator must stand by the operating switch with a part of his body controlling the dead man switch.

3.1.3.1. Description of the recommended, daily preopening inspection to be performed by ride operators and attendants that is in addition to previously performed maintenance or other inspections.

Refer to 3.1.2.3.

3.1.3.2. Description of the recommended ride operators positions and functions.

The ride operator's responsibility is to load the ride properly, fasten the seat belts, take all safety precautions, operate ride, and unload the passengers.

3.1.3.3. Description of the recommended series of steps to be followed in a definite order to complete the operation of the ride.

The operator must load the passengers in the proper order, fasten the safety belts, remind the children to keep arms and hands inside the ride, check the ride for safety, clear area of people, latch the gates, press the dead man switch, press the start button, watch ride until the timer expires, and unload the kids.

3.1.4. Manufacturer's recommended emergency procedures.

The operator must stop the ride immediately and attend to the emergency.

3.1.4.1. Recommended evacuation procedures for the ride.

Remove the children immediately to a safe location.

3.1.4.2. Use of emergency power equipment if provided with the ride.

Not provided.

3.1.4.3 Description of any emergency equipment that is provided with the ride and its uses.

A dead man switch is provided to keep the operator from leaving the ride unattended.

3.1.4.4. Description of any emergency procedure made necessary by an interruption of power, and restart procedures.

The ride will not restart on its own without pushing the restart button.

#### 4.0 MAINTENANCE:

4.1 The manufacturer of an amusement ride shall provide with each ride documented maintenance instructions in the English language. These instructions shall include, but not be limited to the following:

4.1.1. Description of the ride including the function and operation of its major components.

A kiddie ride consisting of an octopus and eight whales that run on a track, moves in a counter-clockwise direction, and goes up and down hills.

4.1.1.1. Description of the designed motions of the ride during operation.

The ride moves in a counter-clockwise direction, and moves up and down hills.

4.1.2. Description of the recommended procedures for installation, setup, disassembly, and transportation of an amusement ride.

First, set up the base in the center of the location. Place the track connectors to the base with the #1 track connector where the electrical cord goes into the base. Place pins in holes and key them. Repeat this through #4 track connector. Then, place #1 track to #1 connector. #1 track has a large hole in it for the electrical cord. Put in pins and key them. Repeat the same procedure for #2 through #4. You cannot get them mixed up. Next, you bolt the track together, but do not tighten it. Put in the squaring rods. This will square the ride. Now tighten the track bolts. Set level on track connectors. Level ride by putting the level jacks down with plates under them. Tighten level jacks. Place Oscar on the stand, and bolt it down. Put the sweeps on #1 through #8. Pin the sweeps into the center and key them. Put Oscar's arms on the ride. Place arms on wheels in center and pin and key them to the sweeps. Place vinyl gear cover over sweeps. Set up fence and gates. Hook up electric to 220 volts. Split the 220 volts to 110 for the motors. Hook up 110 volts to the lights.

To disassemble, reverse the process.

To transport the ride, rack it in a truck or trailer properly.

4.1.3. Recommended lubrication procedures for the amusement ride.

Grease the zerk fittings and check the oil in the gear boxes.

4.1.3.1. Recommended types and specifications of lubricants.

The ride uses standard grease and gear oil.

4.1.3.2. Recommended frequency of lubrication.

The ride should be lubricated when necessary or when it is dry.

4.1.3.3. A lubrication drawing, chart, or instruction, showing the location of lubrication points.

There are two zerkl fittings on the end of the sweeps in the bearings. There is a zerkl fitting on the ends of each truss rod. One zerkl fitting is on every other sweep over the wheel. One zerkl fitting is under the center plate in the hub. The gear boxes are on the motors.

4.1.3.4. Recommended special method of lubrication, where applicable.

Not applicable.

4.1.4. Description of the recommended daily pre-opening inspection to be performed and identification of special care areas and recommended procedures for inspection and maintenance of these areas.

Follow the OABA recommended safety checklist.

4.1.5. Description, including frequency, of recommended maintenance inspections and testing, other than daily pre-opening inspection.

A maintenance inspection should be made when deemed necessary by the owner in accordance with the number of operating hours placed upon the ride.

4.1.5.1. Recommended wear limits or tolerances, where deemed necessary by the manufacturer.

The wear limits or tolerances should be the standard limits.

4.1.5.2. Recommended operational tests, along with minimum intervals for these tests to be performed, that will allow the owner/operator of the ride to determine whether a given ride is operating within recommended prescribed operational limits.

Everyday, the owner/operator should check wheels to make sure they are tracking in the proper position. If they are not tracking in the proper position, loosen the collars. Align the wheels and tighten the collars. Check the truss rods. The bearings should be set 5 degrees off center.

4.1.5.3. Where applicable, recommended nondestructive testing along with appropriate acceptance criteria, including suggested frequency and the special parts or areas to be tested.

A visual check should be made for cracks of any kind in the structure or welds.

4.1.5.4. Tests recommended pursuant to 4.1.5, shall meet the following criteria:

A. The tests shall have been performed satisfactorily by the manufacturer prior to the sale of the amusement ride.

Tests have been performed by the manufacturer.

B. The test shall be a test which the amusement ride can reasonably be expected to pass during the expected life of the amusement ride assuming recommended maintenance and operating procedures have been followed.

C. The test shall be a test that is reasonable, and which the owner/operator can reasonably be expected to be competent to perform or cause to be performed.

4.1.6. Recommended specifications for the use of replacement fasteners, and recommended torque requirements

for fasteners, where applicable. If appropriate, precautionary information will be provided relating to the continued use of fasteners that have been loosened or retorqued.

McGuffey used stainless bolts and pins with lock nuts. It's up to the discretion of the purchaser if he wants to continue this practice.

4.1.7. Schematics of electrical power, lighting, controls, and other systems, including location charts and manufacturer's troubleshooting guide, where applicable.

Schematics are enclosed.

4.1.7.1. Description of recommended maintenance procedures for electrical components.

Standard electrical practices.

4.1.7.2. The name of the component manufacturer and appropriate identification number, specifications, or both, will be provided for electrical components used within the amusement ride.

Placed upon the schematics enclosed. All electrical components are standard.

4.1.7.3. Each electrical component used within the amusement ride will be assigned an individual identification number, symbol, or code to facilitate its location and identity on the electrical schematics.

Each electrical component is marked on the enclosed schematic.

4.1.8. Schematics of hydraulic and pneumatic systems, including recommended pressures, location of components, line specification, fitting specification, type of fluid, location chart, and manufacturer's troubleshooting guide.

Not applicable.

4.1.8.1. Description of recommended maintenance procedures for hydraulic and pneumatic systems and components.

Non-Applicable.

4.1.9. List of parts used in the assembly of the ride or drawings showing component parts and their use.

Parts list for Oscar and the Whales:

| <u>Description</u>         | <u>part no.</u> | <u>Qty.</u> |
|----------------------------|-----------------|-------------|
| 1. Center Base             | OW001           | 1           |
| 2. Center Axle             | MO1             | 1           |
| 3. Center Spindle          | MO2             | 1           |
| 4. Center Plate            | OW002           | 1           |
| 5. Center Lug Nuts         | MO3             | 4           |
| 6. Center Gasket           | OW003           | 1           |
| 7. Commutator Ring         | OW004           | 3           |
| 8. Commutator Brushes      | MO4             | 5           |
| 9. Commutator Brush Holder | MO5             | 5           |
| 10. Oscar Head             | OW005           | 1           |
| 11. Oscar Base             | OW006           | 1           |
| 12. Oscar Arms             | OW007           | 8           |
| 13. Oscar Arms Brace       | OW008           | 8           |
| 14. Oscar Arms Caster      | OW009           | 8           |

|     |                        |           |     |
|-----|------------------------|-----------|-----|
| 15. | Casco Arms Lower Brace | OW010     | 8   |
| 16. | Lower Brace Pins       | OW011     | 8   |
| 17. | Sweep                  | OW012     | 6   |
| 18. | Sweep Mounts           | OW013     | 8   |
| 19. | Sweep Bearing          | 5X692     | 16  |
| 20. | Wheel Axle             | OW029     | 6   |
| 21. | Wheel Bearing          | AP-W2922  | 6   |
| 22. | Wheel Rims             | AP-AP1005 | 16  |
| 23. | Tires                  | AP-AP492  | 8   |
| 24. | Tube                   | AP-7122   | 8   |
| 25. | Drive Hub              | AP-W2921  | 2   |
| 26. | Drive Extention        | OW014     | 2   |
| 27. | Drive Sweep            | OW015     | 2   |
| 28. | Drive Motor            | 5X110     | 2   |
| 29. | Speed Reducers         | 42617     | 2   |
| 30. | Flange Bearing         | 5X705     | 4   |
| 31. | Spreader Bars          | OW016     | 8   |
| 32. | rod ends L             | 55-mm8    | 8   |
| 33. | rod ends R             | 55MB8     | 8   |
| 34. | whales                 | ow017     | 8   |
| 35. | seats                  | ow018     | 8   |
| 36. | safty belts            | ow019     | 8   |
| 37. | Inter hand bars        | ow020     | 8   |
| 38. | track                  | ow021     | 4   |
| 39. | track connectar        | ow022     | 4   |
| 40. | pens                   | 3/8x3     | 8   |
| 41. | pens                   | 1/2x21/2  | 24  |
| 42. | pens                   | 3/8x41/2  | 8   |
| 43. | pens                   | 1/2x21/2  | 8   |
| 44. | bolts                  | 1/2x11/4  | 16  |
| 45. | bots                   | 5/16x11/4 | 32  |
| 46. |                        | 1/2x11/2  | 32  |
| 47. |                        | 3/8x2     | 16  |
| 48. |                        | 1/2x3     | 8   |
| 49. | nuts                   | 1/2lock   | 52  |
| 50. |                        | 5/16 lock | 36  |
| 51. |                        | 3/8       | 16  |
| 52. |                        | 1/4 lock  | 48  |
| 53. | bolt                   | 1/4x11/2  | 32  |
| 54. | 1/4x1 u bolt           |           | 16  |
| 55. | lights                 |           | 144 |
| 56. | 500w light             |           | 3   |
| 57. | fence                  | ow023     | 11  |
| 58. | gates                  | ow024     | 2   |
| 59. | gates feet             | ow026     | 2   |
| 60. | fence feet             | ow027     | 4   |
| 61. | light pole             | owo28     | 3   |

4.1.10. Recommended procedures to be followed in the event of an extended period of non-operation or storage, or both.  
None.

4.1.11. Description of recommended assembly and disassembly techniques and procedures, pertaining to specific components, as deemed necessary by the manufacturer.

None.

4.1.12. Recommended restrictions and special procedures, lubricants, materials, or equipment that may be necessary because of environmental conditions.

None.

4.1.13. Other recommendations known to the manufacturer and specific to certain serial numbered rides.

None.

4.1.14. Maintenance bulletins or similar documents originated by the manufacturer of the amusement ride after the initial instructions have been provided as described in 4.1. will be supplied to all known owner/operators of the amusement ride.

None at this time.

Any and all special modifications that are requested to be made on the Oscar and the Whales or its accessories due to codes, rules, and regulations as placed in force by insurance companies, towns, cities, countries, or other political subdivisions, or government agencies, are the responsibility of the buyer.

Oscar and the Whales meets or exceeds the ASTM standards F-24 as of this date, February 19, 1991.

McGuffey Manufacturing  
Andrew McGuffey, manager  
1514-30th St.  
Parkersburg, WV 26101  
(304) 375-7625

4.1.15. Tire pressure in the eight tires shall be checked daily. Pressure shall be maintained at 50 psi. Do not exceed 57 psi (4.0 kg/cm<sup>2</sup>), in each tire.

### ③ Magnetic Starter

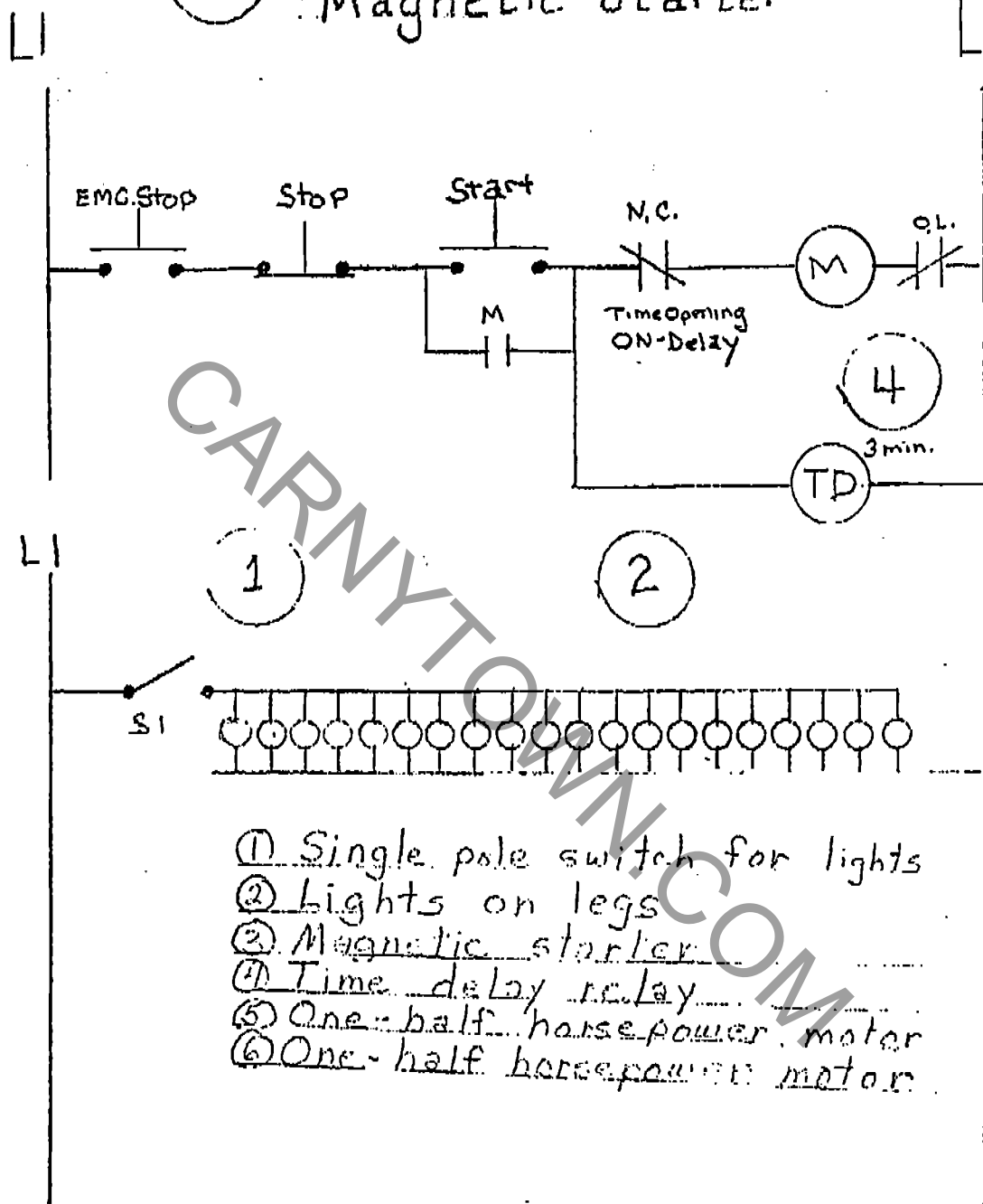

Lights shown on one leg —  
 Typical for B.  
 Motors grounded at source

OSCAR and the Whales

-MAGNETIC STARTER DIAGRAM

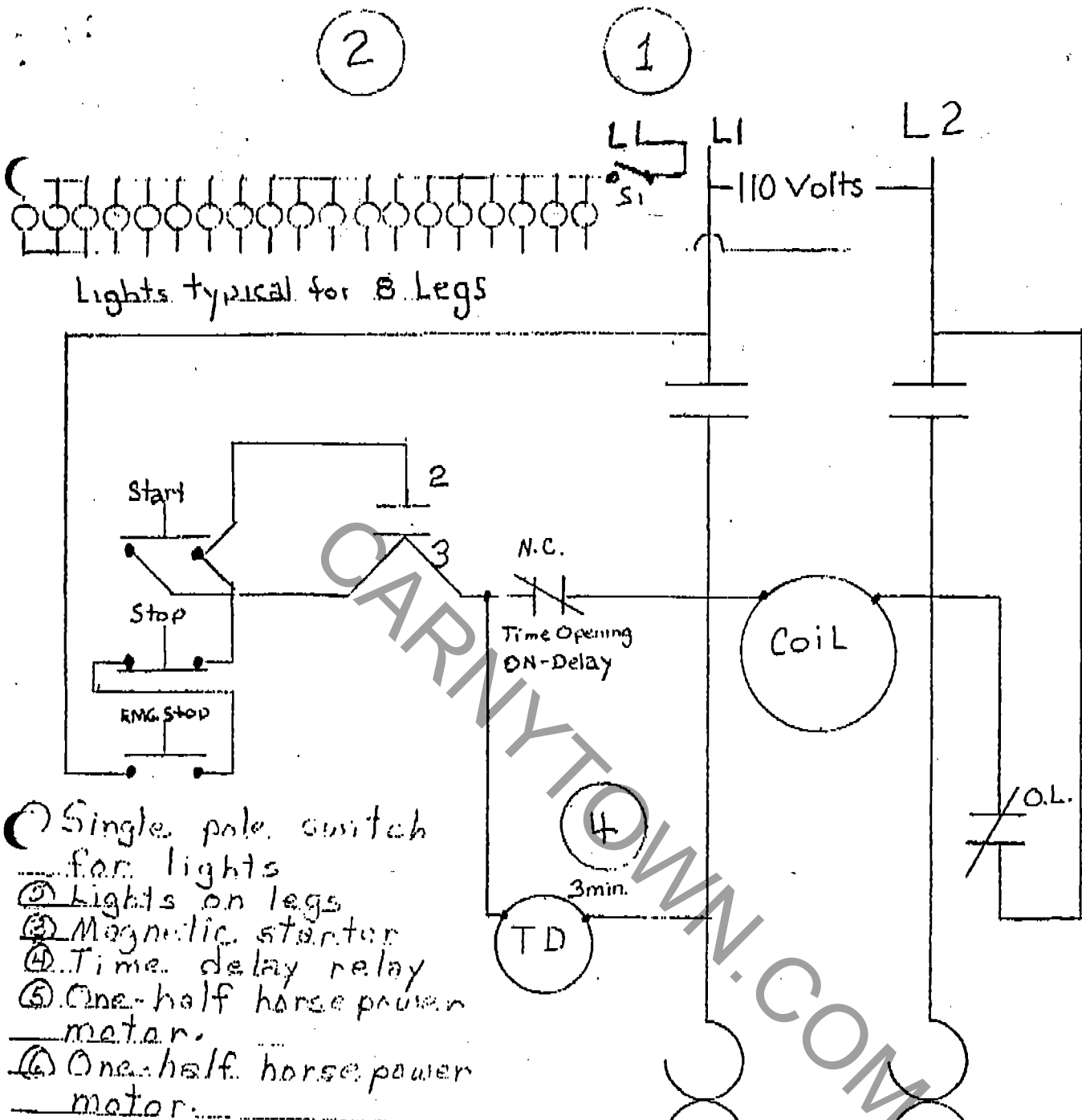

- ① Single pole switch for lights
- ② Lights on legs
- ③ Magnetic starter
- ④ Time delay relay
- ⑤ One-half horse power meter.
- ⑥ One-half horse power motor.

## Oscar and the Whales

WIRING DIAGRAM

