

Rutthoffer

05348

MFG: MAJESTIC RIDES MFG.
NAME: CENTRAL PARK
TYPE: NON-KIDDIE

Central
Park

CARNYTOWN.COM

Majestic

Central
Park
CARNY TOWN.COM

Moje stic

TO THE OWNER AND OPERATOR

This manual contains information concerning the operation, maintenance and safety of your new Central Park Ride. It should be read carefully before attempting to operate your ride. You will find many helpful pointers which will assist you in obtaining the performance for which the ride was designed.

Make note of warranty or claims arising from the use of this manual and the owner-operator assumes complete responsibility for any decisions made or actions taken based on information obtained from using this manual.

BE CAREFUL

The notes appearing in boxes throughout this manual are used whenever personal safety is involved. Take time to be careful for you and the safety of your patrons.

IMPROVEMENTS

The company is continually striving to improve products and reserves the right to make improvements when it becomes practical and feasible to do so, without incurring any obligations or responsibility to make these improvements to rides sold previously.

TABLE OF CONTENTS

	PAGE
WARRANTY.....	1
SAFETY INFORMATION.....	2
PRECAUTIONARY MEASURES.....	3
ASSEMBLY/SET UP PROCEDURE.....	4
CARS.....	5
INSPECTION.....	6
ELECTRICAL SERVICE.....	7
PERIODIC SERVICE.....	8
MAINTENANCE INSTRUCTION.....	9
DAILY INSPECTION SCHEDULE.....	10
CUSTOMER COMMENTS.....	11

HOW TO ORDER

- PHONE -

1-330-457-2447 1-330-457-7280 1-201-983-1296

FAX 1-330-457-7490

KNOWLEDGEABLE STAFF

If you are unsure of your needs, call us. We are the Rides Experts!

SAME DAY SHIPMENT

We strive to ship orders we receive the same day, whenever possible.

This is another example of our commitment of service to you.

IN STOCK, ON THE SHELF

We make it a priority to maintain a high level of replacement ride parts for our customers.

FAST DELIVERY

We offer UPS, Federal Express, Commercial Carrier, etc.

If you have an address, we will get it to you!

- FOR FAST AND EFFICIENT SERVICE -

Having you Parts Book with you when you are placing your order is extremely helpful.

Call us at 330-457-2447 or 330-457-7280.

After business hours you can call your order on our answering service, or

Fax us your order at 330-457-7490.

WHAT WE NEED TO KNOW WHEN YOU CALL:

- * Your company name**
- * Your name**
- * Your phone number**
- * Your complete ship-to address (not your P.O. Box)**
- * Your mailing address if different from above**
- * Your preferred method of shipment**
(ex: UPS next day, UPS ground, Fed Ex, Commercial Carrier)
- * Your style of ride**

WARRANTY

DATE OF DELIVERY JUNE 11, 1997

DATE OF MANUFACTURE JUNE 10, 1997

RIDE SERIAL NUMBER 1M9LN28T7VW276010

MODEL NUMBER TM300

NUMBER OF CARS 5

TYPE OF CARS ANTIQUE CARS

COLOR OF CANVAS HOT PINK TURO YELLOW

1. All parts manufactured by seller, except tires, hydraulics, electrical, battery, etc. which come under each manufacturer's own warranty for a period of six months.
2. The purchaser will pay for any service charge for making service calls and/or transporting the equipment to the place where the warranty work is done.
3. This warranty does not cover depreciation or damage caused by normal wear, accident, improper maintenance, improper protection in storage or improper use. Normal maintenance and service replacement cost will be borne by the purchaser.
4. Seller shall not be liable for loss, damage or expenses directly or indirectly arising from improper use of the ride.
5. Under these conditions all such parts and materials will be invoiced to the customer upon shipment by us of required replacement parts. Full credit will be allowed on such parts subject to the following conditions:
 - A. if they are returned to us, freight PREPAID within a period of fifteen (15) days after date of invoice
 - B. after our examination of said parts they provide to our satisfaction that such defects did exist.
This is our sole obligation under the warranty.

SAFETY INFORMATION

PLEASE TAKE TIME TO READ ALL SAFETY INFORMATION

Unsafe operating practices and improper use of this equipment on the part of the operator can result in injuries. Observe the following safety precautions.

1. Proper blocking for trailer and purlings is essential for safe operation. NOTE: when setting on soft or sandy ground always use a plywood base for blocking. We recommend a 2 1/4" x 1' 0" x 2' 0" plywood base for trailer and 3/4" x 1' 0" x 1' 0" for purling blocking. Always block purlings where the letter B is noted on purling.
2. When raising or lowering trailer, never have anyone stand near or under trailer.
3. When attaching or removing truck from trailer never fully extend hydraulic cylinders. Always use mechanical support stands for extended periods. After support stands are in place, retract hydraulic cylinder. Support pad approximately 1" above bottom of stand base.
4. Overheating 12 volt motors will affect the safe operation of the motors.
 - A. Hydraulic 12 volt motor maximum recommended continuous use is 10 minutes.
 - B. Winch 42 volt motor maximum recommended continuous use is 5 minutes.
 - C. A fully charged battery will ensure proper amperage to 12 volt motors.
5. Proper size safety keys and pins are important, and must be installed in following before operating ride.

A. Track	E. Purlings
B. Fence	F. Ramps
C. Platform	G. Rocking
D. Scenery	H. Railings
6. Never permit customers to run to or from the ride.
NOTE: aluminum decks are slippery when wet.
7. Always have on each car

A. Side Safety Bar
B. Two Seatbelts
8. Never operate cars without everyone wearing seatbelts.
9.

A. Always operate cars at a safe speed.
B. Rectifier speed setting of 3 F.P.S. is recommended
10. The trailer is 28' long, 12' 6" in height. NOTE: Extreme caution must be taken when negotiating corners and low overpasses.
11. The trailers currently being manufactured are equipped with electric trailer brakes but it is advisable to chock trailer wheels when unit is parked.
12.  CAUTION: DO NOT WALK ON TRACK WHILE RIDE IS IN OPERATION
13. After ride is erected, a visual inspection is required to insure there are no electrical shorts between track or other adjacent equipment.
14. To insure safety, the hydraulic switch located by hydraulic unit should be in the off position while ride is in operation. Quick disconnect electrical plug between battery and hydraulic pump, is to be connected at all times.
15. All gates must be closed while ride is in operation.
16. Never ride on back of cars while in operation.
17. Extreme caution is required in high wind when handling scenery or canvas.
18. Safety is an ongoing process. Every operator must use his own judgment for safety due to constant changes in conditions.

THANK YOU

PRECAUTIONARY MEASURES



DO'S

1. KEEP BATTERY FULLY CHARGED.

NOTE: A 10 amp battery charger has a charging rate of 10 amps per hour.

CAUTION! A low battery may damage the hydraulic pump motor or hoist motor.

- 2. When removing or attaching tractor to trailer, trailer must be resting on landing gear support stands, with hydraulic cylinders raised approximately 1" to prevent damage to cylinders.**
- 3. Inspect each and every car prior to operation for safety.**
- 4. Operate cars at a safe, recommended rectifier speed setting of 3 or 3 F.P.S.**
- 5. Chock trailer wheels when unit is parked.**
- 6. Have all customers wear their seatbelts.**
- 7. Turn hydraulic pump switch to the off position before operating ride.**
- 8. Close entrance and exit gates before operating ride.**
- 9. Exercise extreme caution in high winds when handling scenery or canvas.**
- 10. Use the Periodic Service Instruction Sheet on page of the manual to maintain your equipment.**
- 11. Use the Daily Inspection Schedule Sheets provided on page of this manual.**

DON'TS

- 1. Operate ride unless all necessary blocking is in place under trailer frame and purlings.**
- 2. Remove tractor from trailer until trailer is resting on landing gear support stands.**
- 3. Operate electric motors over their recommended maximum continuous usage time.**
- 4. Operate ride until all proper support pins and safety keys have been installed.**
- 5. Operate ride unless all safety features have been installed on cars.**
- 6. Walk on track**
- 7. Operate ride until a thorough visual inspection has been made to assure there are no electrical shorts between track or any adjacent equipment.**
- 8. Operate ride unless the hydraulic pump switch is in the off position.**
- 9. Operate ride until entrance and exit gates are closed.**
- 10. Ride on back of cars.**

SET-UP PROCEDURE

1. Chose a flat and level site. An over all interference area is 76' x 40' . See drawing No# Q-1804.
2. Lay-out all stainless track on ground and attach each section of track with corresponding number. ex: Track No# 1 attaches to track No# 2, etc.
3. All Park model sections bolt together. All portable model track sections use an adjustable tension clamp device. Adjust all clamps with just enough tension to secure sections together then safety key to prevent clamp from opening when ride is setup in operation.
4. Track lay-out must be fairly level for operation if blocking is necessary, follow appropriate guidelines for each state and local blocking codes.
5. Portable units incorporate a trailer that is attached and is part of the ride. Park models are separate. Once track is assembled and all necessary electric plugs, nuts, bolts, fasteners with safety keys are in place a visual inspection is required.

Prior to any patrons being allowed on the ride, all vehicles are to be inspected in accordance with the area's inspection requirements.

1. All seatbelts are in place and functional to factory standards.
2. Side safety bar should be secure and in place. This only permits entry or exit from vehicle from one side only.
3. Any and all sharp objects and/or edges should be removed that would cause injury , accident or incident to any and all patrons or riders.
4. Under carriage area should be in proper working order with all rolling wheels functional and all side anti-lift rollers are in place and functional.
5. All electrical wiring is properly secure and fused with no bare wires or connections exposed.
6. Proper tension on main drive chain less than 1/4" slack between sprockets. Be sure to lubricate chain well.
7. Check for wear on main and secondary wheels, anti-lift wheels, pick-up brushes, etc.
8. Run each car two cycles prior to patron riders to verify safe and functional operation of each car. If there is any reason to question the safe operation of any phase of this unit **CEASE OPERATION** and contact the factory or factory representative for any and all operational and safety concerns.

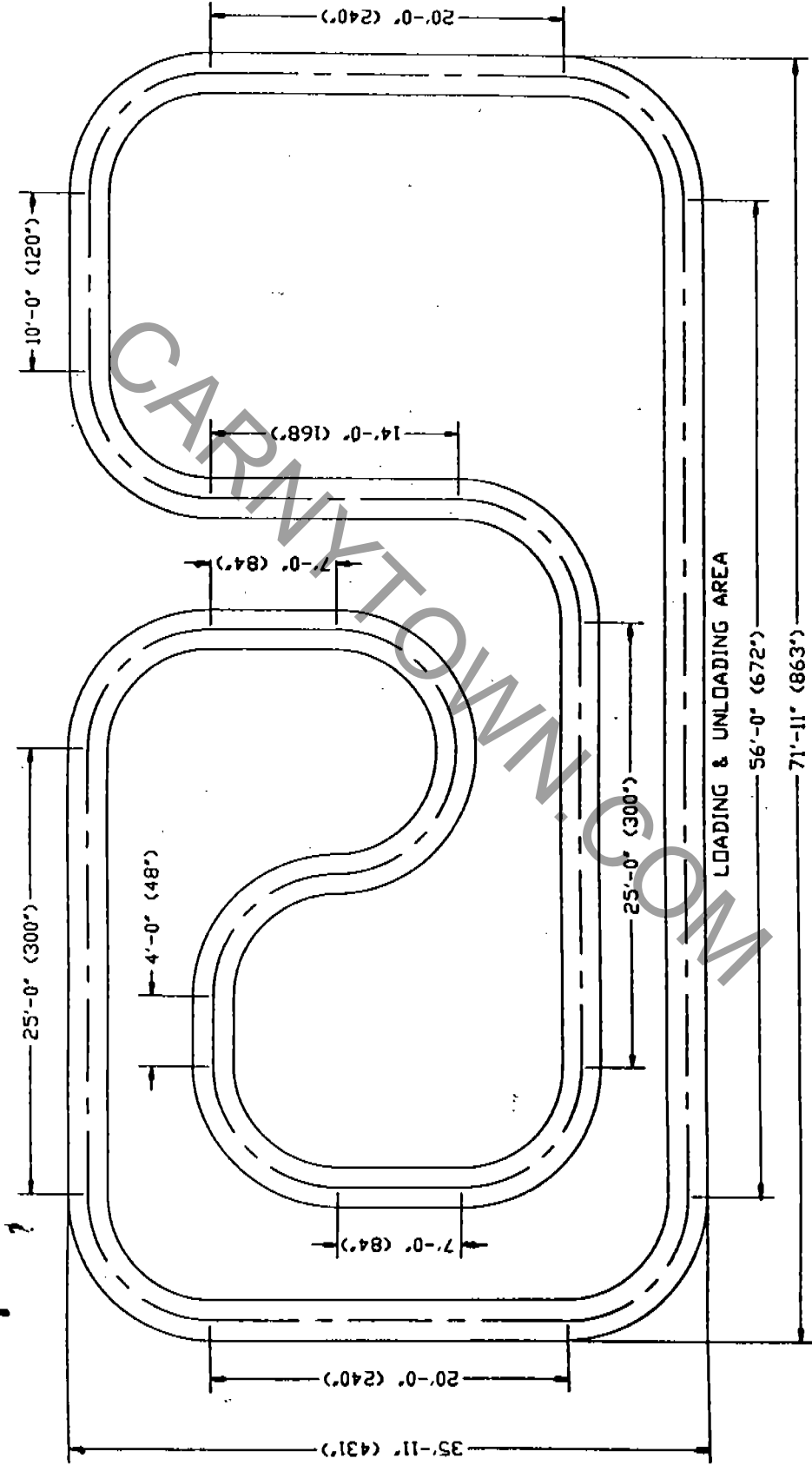

MAJESTIC MFG. INC. 4536 ST RT 7 NEW WATERFORD OHIO 44445	
SCALE:	APPROVED BY: REF. X-XXXX
DATE: 11/9/95	DRAWN BY: T JG
SHEET 1 OF 1	
REVISED 00-00-01	
TRACK LAYOUT	
HOOTERVILLE HIGHWAY	
DRAWING NUMBER Q-1804	

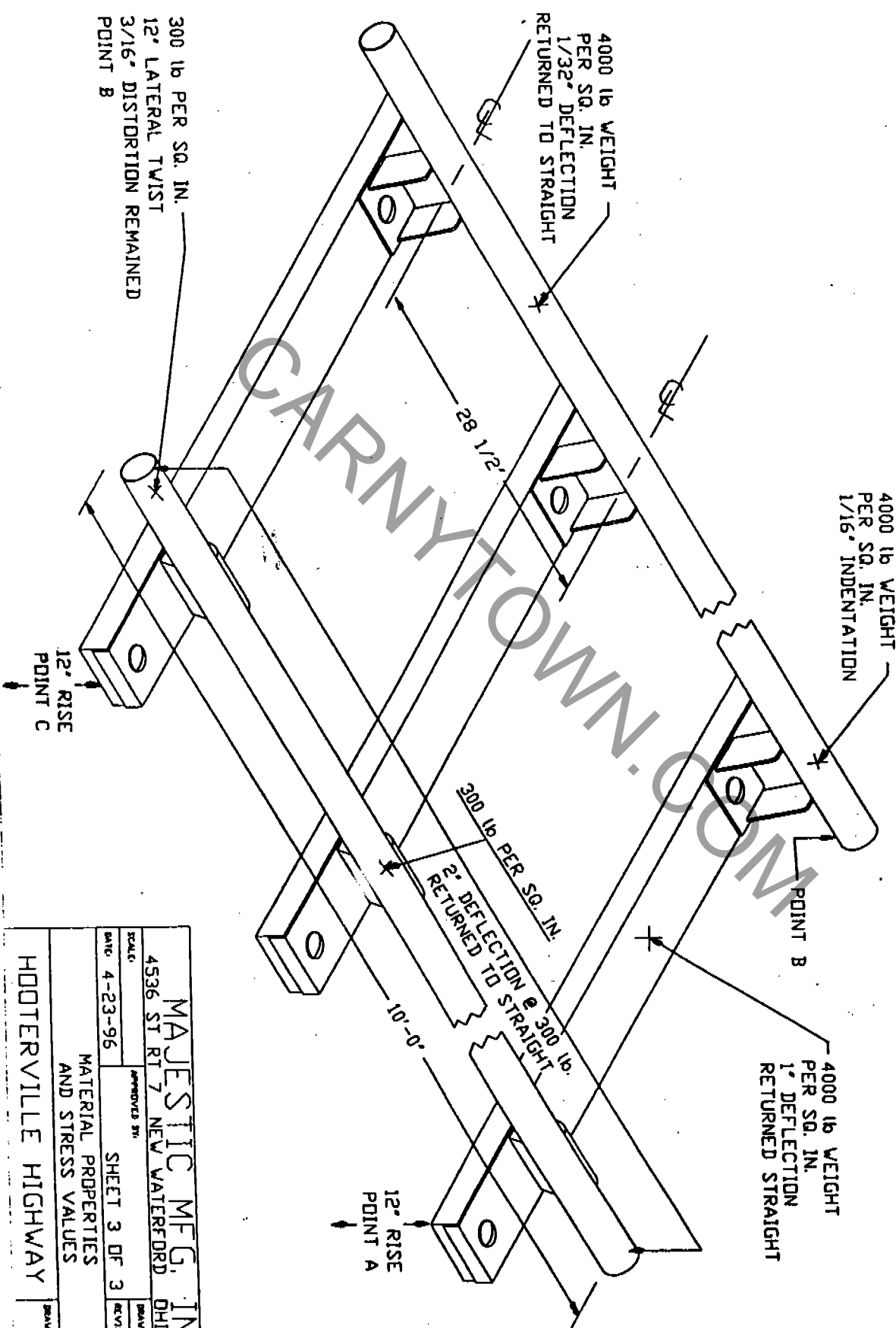

300 lb PER SQ. IN.
 12° LATERAL TWIST
 3/16" DISTORTION REMAINED
 POINT B

12° RISE
 POINT C

4000 lb WEIGHT
 PER SQ. IN.
 1/32" DEFLECTION
 RETURNED TO STRAIGHT

4000 lb WEIGHT
 PER SQ. IN.
 1/16" INDENTATION

4000 lb WEIGHT
 PER SQ. IN.
 1" DEFLECTION
 RETURNED STRAIGHT

300 lb PER SQ. IN.
 2" DEFLECTION @ 300 lb.
 RETURNED TO STRAIGHT

12° RISE
 POINT A

MAJESTIC MFG. INC. 4536 ST RT 7 NEW WATERFORD OHIO 44444	
SCALE: DATE: 4-23-96	APPROVED BY: SHEET 3 OF 3
MATERIAL PROPERTIES AND STRESS VALUES	
HOOTERVILLE HIGHWAY	
DRAWING NUMBER: 0-1806	DRAWN BY: RAS REVISED: 00-00

DURAWOOD PLASTIC LUMBER

DENSITY - .025-.028
 COMPRESSIVE STRENGTH @ 2' - 2540-2580
 4' - 3040-3120
 6' - 5130-5350

TENSILE STRENGTH PSI - 2160-2630
 FLEX MODULUS PSI - 97900-103300
 SHEAR STRENGTH PSI - 1850-2050
 THERMAL EXPANSION in/in/°F - .00007"
 ACCELERATED WEATHERING 91% OF COLDR

TEST CYCLE INCLUDED MATERIALS LISTED ABOVE
 APPROXIMATE WEIGHT OF CAR & SAND USED
 DURING TEST EQUALLED 1,160 LBS. AND DURATION
 TIME WAS ONE HOUR CONTINUOUS USE

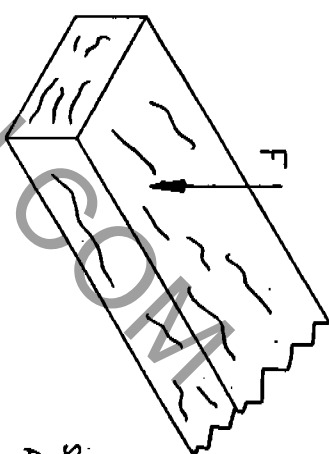

$$S_{SM} = \frac{F}{A}$$

SHEAR STRESS MEAN = 1950 PSI
 A = 8 SQ. IN
 F = 1950 x 8 = 15600 lbs

ALLOWABLE WEIGHT / PIECE

15600 > 1160

WHEELS UHMW PLASTIC

YIELD 2900-3400 PSI
 TENSILE 4600-6800 PSI

MAJESTIC MFG. INC.	
4536 ST RT 7	NEW WATERFORD OHIO 4444
DATE: 11-14-95	REVISION: 00-01
APPROVED BY: REF. X-XXXX	DRAWN BY: STR
SHEET 2 OF 3	

MATERIAL PROPERTIES & STRESS VALUES
 HOOTERVILLE HIGHWAY
 0-1806

RAIL 1 3/4" DIA X 16 GA WALL - 304 STAINLESS STEEL TUBE

**MECH. PROPERTIES
(NOMINAL)**

YIELD STRENGTH (KSI min) 35 **ULTIMATE STRENGTH (KSI min)** 85 **ELONGATION % IN 2"** 55

MOD OF ELAST. lb/in x 10 29 **HARDNESS - BRINELL (MAX)** 180 **HARDNESS - ROCKWELL (MAX)** B90

CHEM. COMP. - CHROMIUM - 17-19%
NICKEL - 8-10%
CARBON - .08%
MANGANESE - 2%
SILICON - 1%

PHYSICAL DATA - MELTING °F - 2550
DENSITY lb/in - 0.29
BTU/°F/lb (32-212°F) - 0.12

CONDUCTIVITY } 212=9.4
BTU/ FT /HR/°F/FT } 432=12.4

MEAN COEFFICIENT OF EXPANSION - 9.2-11

SS = $\frac{F}{AS}$
F = FORCE (LB)
AS = AREA (IN²)

HEAT RESIST - INTERMITTENT °F - 1600
CONTINUOUS °F - 1700

SS = $\frac{1160}{.345 \text{ SQ. IN.}}$ = 3362 PSI

3.3 KSI < 35 KSI

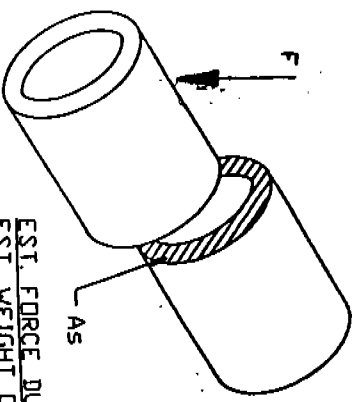

EST. FORCE DURING OPERATION
EST. WEIGHT OF CAR = 660 lbs.
EST. WEIGHT 4 RIDERS = 500 lbs.
TOTAL 1160 lbs.

CALC. SHEAR AREA OF TUBE
AS = R (1 3/4" O.D.) - R (1.62 I.D.)
AS = 2.405 sq. in - 2.06
AS = .345 SQ. IN.

MOUNTING BRKT 11 GA. 304 STAINLESS STEEL PLATE
SAME AS ABOVE

CALCULATED SHEAR STRESS BRKT PLATE

$$SS = \frac{F}{A}$$

$$SS = \frac{1160 \text{ lbs}}{.42 \text{ SQ. IN.}} = 2762 \text{ PSI}$$

27 KSI < 35 KSI

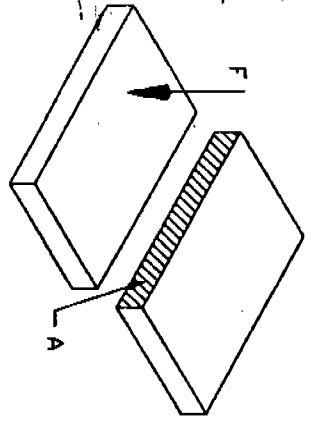

MAJESTIC MFG. INC.		OHIO 44445	
4536 ST RT 7		NEW WATERFORD	
SCALE	APPROVED BY	DRAWN BY	STR
DATE: 11-14-95		REVISED	00-00-00
SHEET 1 OF 3			
MATERIAL PROPERTIES AND STRESS VALUES			
HOOTERVILLE HIGHWAY			
DRAWING NUMBER: Q-1806			

CARS

Each car is equipped with a 36 volt motor to drive each car.

To operate each car, four zones are incorporated in the staging area. Jog cars forward by depressing each zone button.



Never jog car with a patron standing, stepping or moving in car. Injury is possible. Always know what zone button corresponds to car affected.

Recommended speed setting is 3 F.P.S. (feet per second) this may vary depending on total weight per car. Operator discretion is recommended.



An emergency shut off switch is located on operators panel. If for any reason there is a safety concern, USE IT. It is recommended that the switch is tested on a regular basis to insure reliability.

Proper spacing is required when ride is in operation.



Never operate cars too close. 15' - 20' of spacing is necessary between each car.



Never operate cars with any part of the rider's body out of the car, ex: head, arms, legs. The rider/patron should be completely seated in the designed seat.



Never operate cars unless a daily inspection has been performed

CARNYTOWN.COM

INSPECTION

- I. Cars - see section 4 for total inspection of cars.**

- II. Track - see section 4 for total inspection of track.**

- III. Trailer**
 - 1. Trailer must be firmly blocked prior to operation.**
 - 2. All fencing and one way gates must be in place prior to operation.**
 - 3. All ramps must have anti-skid strips installed and secure.**
 - 4. All safety keys and pins are in place.**
 - 5. Safety rules visible and in tact.**

C E N T R A L P A R K

Inspection Schedule Operational

1. All wiring is in accordance with state, local and manufacturers' guidelines.
2. Trailer is secure and blocked properly.
3. Track is attached together and blocking is such that as car travels around corners, car will not tip over.
4. When loading cars with customers, some very important factors:
 - a) Distribute load evenly. Eg: Never have car unbalanced. Car can tip over around corners if not properly distributed.
 - b) Never exceed 500 lbs. total weight
 - c) Have all customers conform to safety rules posted on front of ride
 - d) Always walk the track before operating for the day.
 - e) Always inspect interior of car before operating for the day. Eg: Sharp objects, loose or non-functional seat belt.
 - f) Inspect all hook rollers for proper distance from rail.
 - g) Inspect above trailer for any loose objects that may fall on a patron or person.
 - h) Is one way gate system functional and operating properly?

Any questions concerning the safety of this unit, call MAJESTIC MANUFACTURING, INC. Monday thru Friday, 8:00 AM - 4:30 PM at 330-457-2447.

5. Preventive maintenance is very important.
 - a) Oil chain every 10 hours of use.
 - b) Check tension - 1/4" of play from sprocket to sprocket is normal.
 - c) Hook rollers last longer with a small amount of oil on the shaft every week.
 - d) Hard hitting of cars in the staging area will do damage and excessive wear on cars.

ELECTRICAL SERVICE

Trailer model - 5 cars Total/320 feet of Stainless Steel Track

A. Total power requirements
amps 100 amp service
volts 220 volt 1 phase

B. Power requirement per car average
amps 8 amps
volts 42 volts

Park Model - 5 car Total/320 feet of Stainless Steel Track

Total power requirements
amps 55 amp service
volts 220 volt 1 phase

CARNYTOWN.COM

RECTIFIER

OPERATION:

1. Never operate the unit with any panel removed when under load.
2. Turn the voltage control counterclockwise (to the left) so that the dial indicator is on the "1" position of the dial plate. This is the setting for the lowest possible output voltage available.
3. After the power supply is installed as above, apply the line voltage to it.
4. Energize the "Timer".
5. Turn the voltage control knob clockwise (to the right) to increase the output voltage.
6. The ammeter and voltmeter will monitor the D.C. output. The ammeter will only read when the load is supplied.



CAUTION: DO NOT EXCEED A D.C. OUTPUT VOLTAGE GREATER THAN THE NAMEPLATE RATING. ADDITIONAL VOLTAGE IS AVAILABLE TO COMPENSATE FOR POSSIBLE LOW INCOMING LINE VOLTAGES. DO NOT CHANGE SPEED WHILE UNDER LOAD.

7. Do not load the unit in excess of the nameplate rating. In the event of an overload, ground or short the load, the D.C. ampere output and/or clear the ground before restarting the power supply.
8. The RED pilot light will indicate POWER ON.
9. REMOTE KILL SWITCH: TB-3 makes provisions for wiring up a remote "KILL SWITCH" at the work area. Opening this remote switch prevents the Power Supply from allowing its output.

MAINTENANCE:

1. Rectifier elements **MUST** be kept clean to insure proper ventilation. Dirt accumulations will result in improper cooling, causing excessive overheating, which will eventually damage the rectifier elements and other components. We urge cleaning of the power supply every six months, using compressed air or a vacuum cleaner. Do not place objects on top, as they will restrict the air flow and damage components. Fan motors (of 1/4 and 1/3 HP) are packed with sufficient grease for approximately five years of operation under normal conditions. After five years, the bearing and housings should be cleaned thoroughly and repacked. Smaller fan motors should be oiled carefully every six months.
2. Inspect all cables, wires and connections for loose connection or overheating. If hot looking spots are found, repair them before they open up, causing serious trouble.
3. Check the calibration of the meters. They should be kept within 2% accuracy of the

full scale readings. Watch for sticking of the pointer. See that the pointers are zeroed.

4. In case of blown diodes, the following steps should be taken:

A. Before replacing the blown diode, the reason or cause of failure should be determined. The diode or diodes in the affected circuit should be isolated (disconnect the pig-tail end)

B. Each diode should then be checked for forward and reverse resistance.

NOTE: IF THE DIODE IS GOOD, THE LOW RESISTANCE READING SHOULD BE VERY LOW, APPROXIMATELY 10 TO 20 OHMS. THE HIGH RESISTANCE WOULD BE IN THE RANGE OF 1,000 OHMS TO 50,000 OHMS. THIS IS VARIABLE IN DIODES. IF BOTH READINGS ARE HIGH, THEN THE DIODE SHOULD BE CONSIDERED BAD AND REPLACED. IF NO CONTINUITY IS FOUND, THE DIODE IS OPEN AND SHOULD BE REPLACED.



CAUTION: NEVER OPERATE THE UNIT WITHOUT THE FAN OR WITH ANY PANEL REMOVED WHEN UNDERLOAD. AFTER UNIT HAS BEEN CLEANED, BE SURE PANELS ARE PUT BACK.

ORDINARY MAINTENANCE

A. Drive Chain

- 1) The drive chain's tension of the cars has to be controlled monthly. The admitted oscillation is about 2-3 mm. If this oscillation is higher, the chain has to be taken in tension, then unfasten the nuts and move the reduction gear until you reach the desired result. Inspect the correct centering between the reduction gear's pinion and the engine crown. Then block all with the nuts.
- 2) Lubricate the chain weekly with automatic transmission fluid.

B. Electric System

- 1) Motor brushes - Verify every two months the brushes' wearing of the car's engine. To inspect brushes it is necessary to remove the crankcase.
- 2) Track brushes - Inspect monthly the condition of the feeding brush and replace it if it is necessary.
- 3) Grounding - Carry out a proper grounding of the attraction while installing and inspect its conditions daily. N.B. This connection and the control has to be carried out by competent staff.
- 4) Controls - Check daily the press button's functions state, stop and emergency.

C. Guide Roller

- 1) Check weekly the car hold down rollers and replace it if it is necessary.

D) Trolley Wheels

- 1) Inspect the wearing of the eight cast nylon wheels of the car and replace them it is necessary.

E. Drive Wheels

- 1) Inspect the center rubber section of the drive wheel and replace them if necessary.

CARNYTOWN.COM

DAILY INSPECTION SCHEDULE

INITIAL APPROPRIATE BLOCK AFTER INSPECTION. DATE: WEEK ENDING MO. DAY YR		MONDAY	TUESDAY	WEDNESDAY	THURSDAY	FRIDAY	SATURDAY	SUNDAY	COMMENTS	
RIDE UNIT	RECTIFIER SPEED SETTING ●									
	ALL FENCE INSTALLED									
	GATES OPERABLE									
	RAMPS AND HINGE PINS INSTALLED									
	RAMP ANTI-SKID									
	RAMP RAILING & SPRING PINS INSTALLED									
	Track Secure Bolt Clamps & R Keys									
	HYDRAULIC SWITCH OFF									
	FENCE GUARDS INSTALLED (IF APPLICABLE)									
	CONTINUITY Blocking (If Applicable)									
	SAFETY RULES LEDGEABLE									
	SAFETY KEYS									
	EXITS NOT BLOCKED									
	All Electrical Connections									
	CAR	SEAT BELTS								
		Safety Side Bar								
Motor, Gear Box, Chain										
Bumpers										
Running Gear										
Electrical Speed Setting										
CAR INTERIOR CLEAN										
Car Interior Defects										
Sharp Objects Interior & Exterior										

CENTRAL PARK TRACK RACKING

1. ALL CURVE SECTIONS OF TRACK ARE TO BE RACKED FIRST. THE TIES OF THE FIRST CURVED SECTION RACK AGAINST TRAILER FRAME. REMAINING CURVES ALTERNATE THEREAFTER.
2. RACK THE FOUR 6' SECTIONS OF TRACK NEXT.
3. RACK THE SECTIONS OF TRACK WITH THE CAR GUIDERAIL MOUNTED TO THE TRACK.
4. RACK ONE 4' SECTION OF TRACK AND THEN ONE 10' SECTION OF TRACK AND THEN RACK THE OTHER 4' SECTION AND THEN THE OTHER 10' SECTION.
5. RACK REMAINING STRAIGHT PIECES OF TRACK.

C A U T I O N

Tighten Wheel Lugs

Tighten cone type nuts to 175 to 225 Lb. - Ft.
Tighten flange type nuts to 275 to 325 Lb -
Ft.

On first road use, re-tighten lugs at the
first 50 miles and 100 miles. Check lugs
regularly thereafter.

CARNYTOWN.COM

CERTIFICATE OF FLAME RESISTANCE



Registered Application Concern No.

F-306.1

ISSUED BY
WATERLOO TENT & TARP CO., INC.
1029 COMMERCIAL ST.
WATERLOO, IA 50702
319-234-4679 800-5371193

Date Work Performed

February, 1997

This is to certify that the material described have been flame retardant treated (or are inherently nonflammable).

Majestic Mfg.

P. O. Box 128 New Waterford OH 44445

Certification is hereby made that:

- The articles described below on this Certificate have been treated with a flame retardant chemical approved and registered by the State Fire Marshal and that the application of said chemical was done in conformance with the laws of the State of California and the roles and regulations of the State Fire Marshal.

Name of chemical used

Chem. Reg. No.

Method of Application

- The articles described below on the Certificate are made from a flame-resistant fabric or material registered and approved by the State Fire Marshal for such use.

Trade name of flame resistant fabric or material used

Sunburst

Reg. No.

F-306.1

The flame Retardant Process used **WILL NOT** Be Removed By Washing

Meridian Mfg.

Jimmie Robertson

Production Company

Quality Control Supervisor

We hereby certify this to be a true copy of the original "CERTIFICATE OF FLAME RESISTANCE" issued to us, "original copy" of which has been filed with the California State Fire Marshall.

WATERLOO TENT & TARP CO. INC.

BY 

Customer Number maj44445

Order # 8220

P.O. Number

Items (1) Hooterville Awning Description

Hot Pink-Turq-Yellow Stripe Width 15"

Color

Type & Weight of Material 14 oz. vinyl

IMPORTANT!!!

DO NOT LOSE

**THIS IS PROOF THAT YOUR TOP IS FLAME
RETARDANT FIRE MARSHALLS WILL ASK TO
SEE THIS CERTIFICATE**

CARNYTOWN.COM

MANUFACTURER'S STATEMENT OF ORIGIN TO A TRAILER

The undersigned corporation hereby certifies that the new trailer described below, the property of said corporation, has been transferred

this _____ Tenth _____ day of

_____ JUNE _____, 19 97, on Invoice No. _____ H010 _____

to _____ REITHOFFER EQUIPMENT INC. _____
(Distributor, Dealer, Etc.)

whose address is _____ 500 DUAL HIGHWAY SEAFORD, DE 19973 _____
(Street, City and State)

Trade Name _____ CENTRAL PARK _____ Year _____ 1997 _____ Model _____ TM 300 _____

Type _____ FLATBED _____ Serial _____ 1M9LN28T7VW276010 _____ Weight _____ 14,500 LBS _____

The corporation further certifies that this was the first transfer of such new trailer in ordinary trade and commerce.

MAJESTIC MANUFACTURING, INC.

By _____ *Jeff Kudler* _____ PRES _____
Sign Name Title or Position

Rt. 7, New Waterford, Ohio 44445

FIRST ASSIGNMENT

FOR VALUE RECEIVED, the undersigned hereby transfers this Statement of Origin and the trailer described therein to REITHOFFER EQUIPMENT CO., INC.

Address 500 DUAL HIGHWAY SEAFORD, DE

and certifies that the trailer is new and has not been registered in this or any other state: he also warrants the title of said trailer at time of delivery, subject to the liens and encumbrances, if any, as set out below:

Amt. of Lien Date To Whom Due Address

Dated JUNE 10, 1997, at NEW WATERFORD, OH

MAJESTIC MANUFACTURING, INC. By: Jeff Kudler PRES.
Transferor (Firm Name) Sign Here Position

Before me personally appeared _____ who by me being duly sworn upon oath says that the statements set forth above are true and correct. Subscribed and sworn to before me this 10th day of June, 1997

Notary Public for COLUMBIANA County, State of OHIO
CANDICE L. HANCOCK
Notary Public, State of Ohio
9-79-01
My Commission Expires



SECOND ASSIGNMENT

FOR VALUE RECEIVED, the undersigned hereby transfers this Statement of Origin and the trailer described therein to _____

Address _____

and certifies that the trailer is new and has not been registered in this or any other state: he also warrants the title of said trailer at time of delivery, subject to the liens and encumbrances, if any, as set out below:

Amt. of Lien Date To Whom Due Address

Dated _____, at _____

By: _____
Transferor (Firm Name) Sign Here Position

Before me personally appeared _____ who by me being duly sworn upon oath says that the statements set forth above are true and correct. Subscribed and sworn to before me this _____ day of _____, 19____

Notary Seal
Notary Public for _____ County, State of _____

THIRD ASSIGNMENT

FOR VALUE RECEIVED, the undersigned hereby transfers this Statement of Origin and the trailer described therein to _____

Address _____

and certifies that the trailer is new and has not been registered in this or any other state: he also warrants the title of said trailer at time of delivery, subject to the liens and encumbrances, if any, as set out below:

Amt. of Lien Date To Whom Due Address

Dated _____, at _____

By: _____
Transferor (Firm Name) Sign Here Position

Before me personally appeared _____ who by me being duly sworn upon oath says that the statements set forth above are true and correct. Subscribed and sworn to before me this _____ day of _____, 19____

Notary Seal
Notary Public for _____ County, State of _____

Midway Engineering

June 18, 1996

Ms. Ann Millben
Michigan Dept. of Commerce
Carnival-Amusement Safety Unit
P.O. Box 30018
Lansing, MI 48909-7518

Dear Ms. Millben:

Ref: Central Park Series Ride by Majestic Manufacturing Inc.

In accordance with a request by Mr. Jeff Kudler of Majestic Manufacturing, my services as a professional engineer were utilized with regard to the Central Park Series Ride. This ride will be manufactured in a number of themes (i.e. Central Park, Hooterville Highway, etc.) with similar components. This certification will be applicable to all themes in the series.

Enclosed are copies of the Engineering Drawings, Specifications, Engineering Analysis, and Operation and Maintenance Manual. The Drawings and Analysis have been reviewed in accordance with the requirements of the Michigan Carnival Amusement Safety Act. The results of the review of the Analysis are as follows:

- 1) The assumptions and theory utilized are based upon sound engineering practice.
- 2) The references utilized are applicable to the type of analysis being performed.
- 3) The loads which were utilized are the maximums to be expected during the life of the amusement device.
- 4) The stresses calculated do not exceed 50% of the material yield strengths.

My conclusion based upon the above results is that the Engineering Analysis indicates that the Central Park Series Ride can safely sustain the imposed loads when operated in accordance with the manufacturers instructions.

Based upon the above conclusion, I do hereby certify the Engineering Drawings and Analysis for the Central Park Series Ride manufactured by Majestic Manufacturing Inc. of New Waterford, Ohio.

Should you have any questions regarding the above, please contact me at my office. Thank you for your help in this matter.

Sincerely,

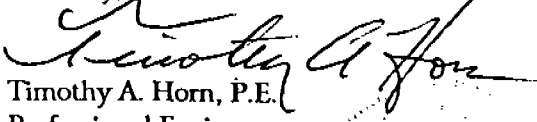
Timothy A. Horn, P.E.
Professional Engineer

c: Mr. Allen Chester
Mr. Jeff Kudler ✓
Mr. Len Soled
Enclosures

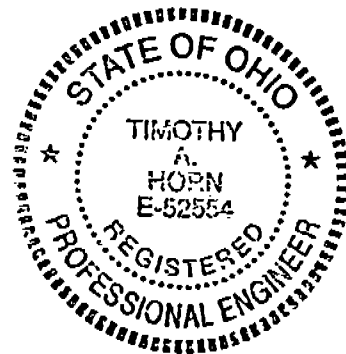

CARNYTOWN.COM



2695 SPRINGMILL RD. • MANSFIELD, OH 44903
(419) 747-4708 FAX (419) 747-4715

ENGINEERING ANALYSIS		
CENTRAL PARK SERIES RIDE		
pg. 1 of 12	06-04-96	TW

1.0) SCOPE

THE FOLLOWING ENGINEERING ANALYSIS IS INTENDED TO DEMONSTRATE THAT THE CENTRAL PARK SERIES RIDE MANUFACTURED BY MAJESTIC MANUFACTURING OF NEW WATERFORD, OH CAN SAFELY SUSTAIN THE LOADS IMPOSED WHEN OPERATED IN ACCORDANCE WITH THE OPERATORS MANUAL. THIS RIDE WILL BE THEMED UNDER SEVERAL NAMES INCLUDING CENTRAL PARK, HOOTERVILLE HIGHWAY, ETC. THIS ANALYSIS IS APPLICABLE TO ALL THEMES IN THE SERIES WHICH UTILIZE THE SAME MECHANICAL COMPONENTS.

2.0) MAXIMUM LOADED WEIGHT

VEHICLE STATIC WEIGHT — 700 LBS.
MAX. CAPACITY — 800 LBS.

TOTAL LOADED WT. 1500 LBS.

WEIGHT DISTRIBUTION
FROM WEIGHING VEHICLES.

60% REAR
40% FRONT

FRONT AXLE LOAD. = 600 LBS.
REAR AXLE LOAD = 900 LBS.



2695 SPRINGMILL RD. • MANSFIELD, OH 44903
(419) 747-4708 FAX (419) 747-4715

ENGINEERING ANALYSIS		
CENTRAL PARK SERIES RIDE		
pg. 2 of 12	06-04-96	TML

3.0) REFERENCES

- A) CENTRAL PARK OPERATION MANUAL
- B) CENTRAL PARK DRAWINGS & SPECIFICATIONS
- C) MACHINERY'S HANDBOOK
21st. EDITION INDUSTRIAL PRESS
- D) MECHANICAL ENGINEERS HANDBOOK
EIGHTH EDITION MARKS

4.0) ALLOWABLE STRESSES

- A) STEEL SHEET, TUBE, & BAR YIELD 36,000 psi.
ASTM A-36
ALLOWABLE (50% YIELD) 18,000 psi.
- B) STAINLESS STEEL YIELD 35,000 psi.
ASTM A 304
ALLOWABLE (50% YIELD) 17,500 psi.
- C) STEEL TUBE DIN 17100 YIELD 50,000 psi.
EQUAL TO ASTM A-572
(FRAME OF CAR) ALLOWABLE (50% YIELD) 25,000 psi.
- D) UHMW PLASTIC YIELD 3,500 psi.
ALLOWABLE (50% YIELD) 1,500 psi.



2695 SPRINGMILL RD. • MANSFIELD, OH 44903
 (419) 747-4708 FAX (419) 747-4715

ENGINEERING ANALYSIS		
CENTRAL PARK SERIES RIDE		
pg. 3 OF 12	06-05-96	TW

- E) SAE GRADE 5 BOLTS YIELD 150,000 psi
 ASTM A 354
 ALLOWABLE (50% YIELD) 75,000 psi
- F) SAE GRADE 2 BOLTS YIELD 69,000 psi
 ALLOWABLE (50% YIELD) 34,500 psi

5.0) TRACK TUBING

MAXIMUM LOAD IS BY REAR AXLE = 900 LBS.
 OVER

(4) WHEELS $P = \frac{900}{4} = 225$ LBS.

TRACK TIE SPACING MAX. = 29 IN.

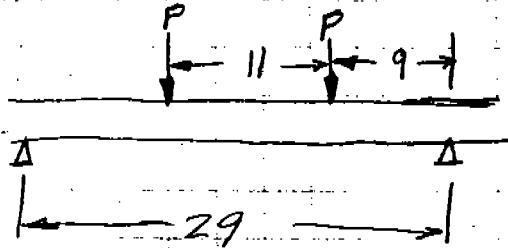

REF. D, pg. 5-35
 $M_{max} = \frac{P}{2l} (l - \frac{a}{2})^2$
 $= 2,142$ LB. IN.

1.75 D

 1.62 d
 FROM REF. C, pg. 372
 $I = .049 (D^4 - d^4)$
 $= .122$ IN.⁴

$\sigma = \frac{Mc}{I} = \frac{(2,142)(.875)}{.122} = 15,365$ psi.

FACTOR OF SAFETY

$\Sigma = \frac{18,000}{15,365} = 1.17$ OKAY



2695 SPRINGMILL RD. • MANSFIELD, OH 44903
 (419) 747-4708 FAX (419) 747-4715

ENGINEERING ANALYSIS		
CENTRAL PARK SERIES RIDE		
pg. 4 of 12	06-06-96	TJM

6.0) TRACK MOUNTING BRACKET

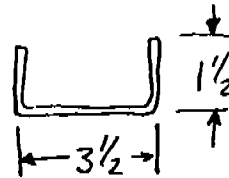
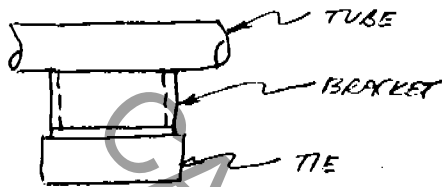

$t = .120$
 TYPE 304
 S.S.

$A = .78 \text{ in}^2$

LOADING IS FROM (2) WHEELS OR 450 LBS.

$$\sigma = \frac{P}{A} = \frac{450 \text{ LBS.}}{.78 \text{ IN}^2} = 577 \text{ PSI.}$$

FACTOR OF SAFETY

$$\phi = \frac{17,500}{577} = \underline{\underline{30.3 \text{ OKAY}}}$$

7.0) TRACK CROSS TIES

SEE ITEM 6.0 ABOVE.

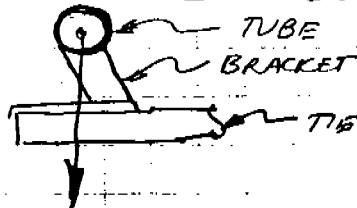

2x4 DURAWOOD.
 $A = 8 \text{ IN}^2$

450#

$$\sigma = \frac{P}{A} = \frac{450 \text{ LBS.}}{8 \text{ IN}^2} = 56 \text{ PSI.}$$

FACTOR OF SAFETY

$$\phi = \frac{1,300}{56} = \underline{\underline{23.1 \text{ OKAY}}}$$



2695 SPRINGMILL RD. • MANSFIELD, OH 44903
(419) 747-4708 FAX (419) 747-4715

ENGINEERING ANALYSIS		
CENTRAL PARK SERIES RIDE		
pg. 5 OF 12	06-06-96	<i>ML</i>

8.0) INSULATOR ROAD WHEELS

5 1/4" DIA. x 2 3/4" WIDE
UHMW PLASTIC.

MAXIMUM LOAD PER WHEEL = 225 LBS.

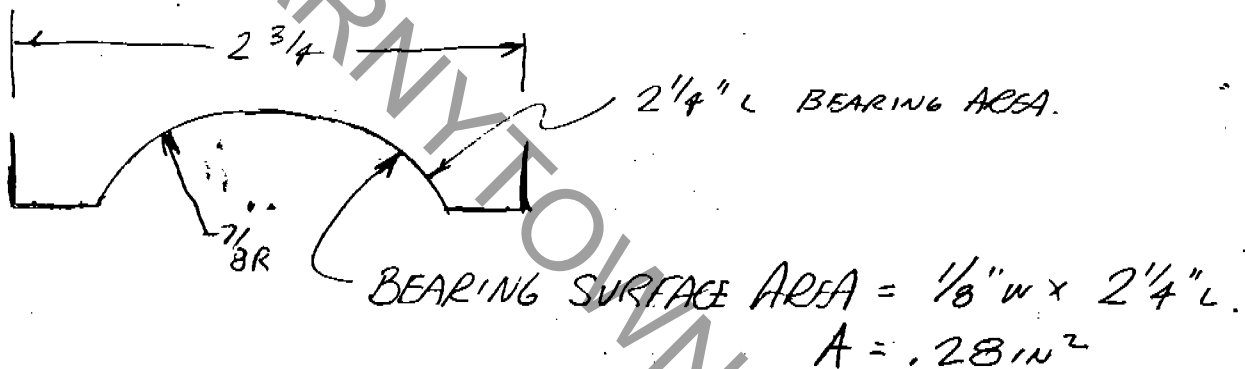

$$\delta = \frac{225 \text{ LBS}}{.28 \text{ in}^2} = 800 \text{ PSI}$$

FACTOR OF SAFETY

$$C = \frac{1,500}{800} = 1.88 \quad \text{OKAY}$$

9.0) ROAD WHEEL BEARINGS

MAXIMUM LOAD PER WHEEL = 225 LBS.

EACH WHEEL HAS (2) BEARINGS RATED
AT 843 LBS.

TOTAL CAPACITY = 843(2) = 1686 LBS.

FACTOR OF SAFETY

$$C = \frac{1686}{225} = 7.49 \quad \text{OKAY}$$



2695 SPRINGMILL RD. • MANSFIELD, OH 44903
 (419) 747-4708 FAX (419) 747-4715

ENGINEERING ANALYSIS		
CENTRAL PARK SERIES RIDE		
pg. 6 of 12	06-07-96	TW

REF. C, pg. 372

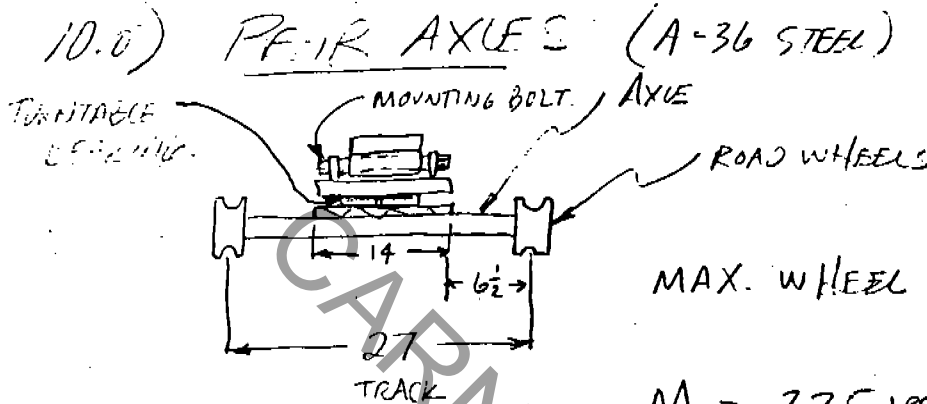

$I = .055 d^4$
 $= .197 \text{ in}^4$

MAX. WHEEL LOAD = 225 LBS.

$M = 225 \text{ LBS.} (6 \frac{1}{2} \text{ IN.})$
 $= 1,462 \text{ LB IN.}$

$\sigma = \frac{Mc}{I} = \frac{(1,462)(.687)}{.197}$
 $= 5,098 \text{ psi.}$

FACTOR OF SAFETY

$\delta = \frac{18,000}{5,098} = 3.53 \text{ OKAY}$

11.0) REAR TURNABLE BEARING

5" DIA. RATED @ 4,950 LBS.

TOTAL REAR AXLE LOAD = 900 LBS.

FACTOR OF SAFETY

$\delta = \frac{4,950 \text{ LBS.}}{900} = 5.5 \text{ OKAY.}$



2695 SPRINGMILL RD. • MANSFIELD, OH 44903
 (419) 747-4708 FAX (419) 747-4715

ENGINEERING ANALYSIS
 CENTRAL PARK SERIES RIDE

pg. 7 of 12 06-08-96 TJK

12.0) TURNTABLE MOUNTING BOLT - REAR

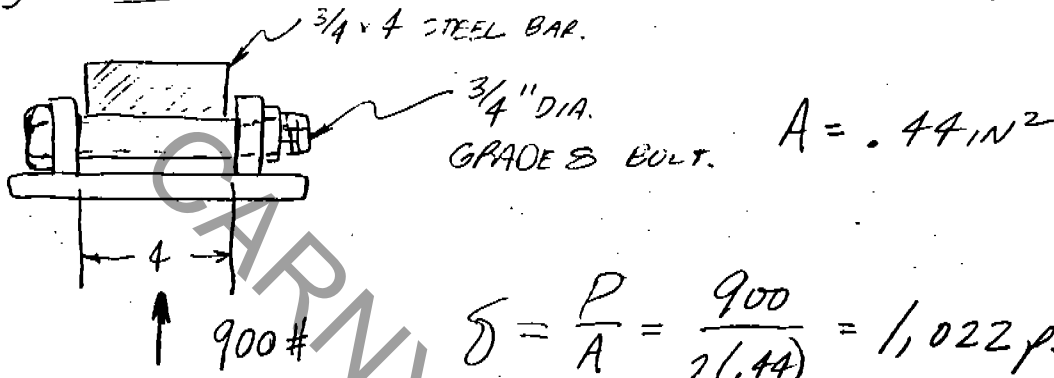

$$\sigma = \frac{P}{A} = \frac{900}{2(.44)} = 1,022 \text{ psi.}$$

FACTOR OF SAFETY

$$F = \frac{75,000}{1,022} = 73.3 \text{ OKAY}$$

13.0) TURNTABLE MOUNTING FRAME - REAR

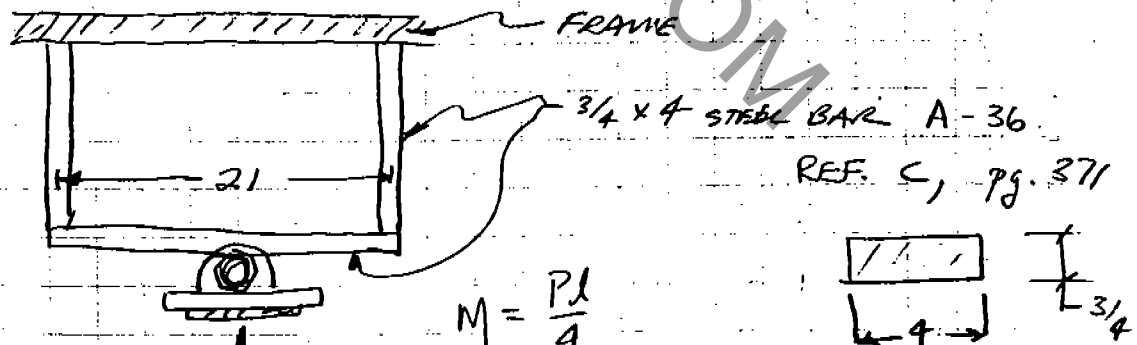

$$M = \frac{Pl}{4} = \frac{900(21)}{4} = 4,725 \text{ IN. LB.}$$

$$I = \frac{bd^3}{12} = \frac{(4)(.75)^3}{12} = .14 \text{ IN.}$$

$$\sigma = \frac{M_c}{I} = \frac{(4,725)(.375)}{.14} = 12,656 \text{ psi.}$$

FACTOR OF SAFETY

$$F = \frac{18,000}{12,656} = 1.42 \text{ OKAY}$$



2695 SPRINGMILL RD. • MANSFIELD, OH 44903
 (419) 747-4708 FAX (419) 747-4715

ENGINEERING ANALYSIS		
CENTRAL PARK SERIES RIDE		
pg. 8 of 12	06-9-96	<i>[Signature]</i>

14.0) FRONT WHEEL BOLTS

FRONT AXLE LOAD = 600 LBS.

OVER (4) WHEELS $P = \frac{600}{4} = 150$ LBS.

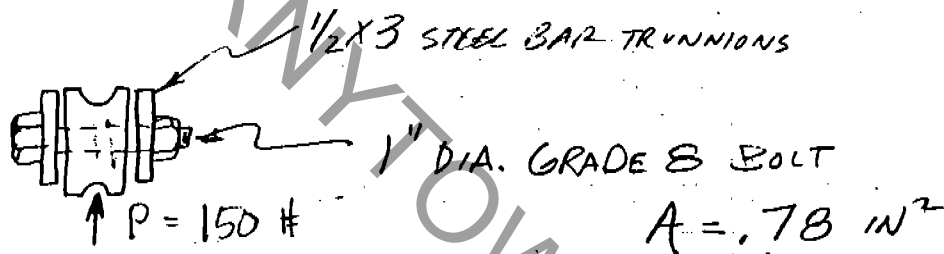

$$\sigma = \frac{150 \text{ LBS}}{(2)(.78)} = 96 \text{ PSI}$$

FACTOR OF SAFETY

$$\delta = \frac{75,000}{96} = \underline{785} \text{ OKAY}$$

15.0) FRONT AXLE TRUNNION

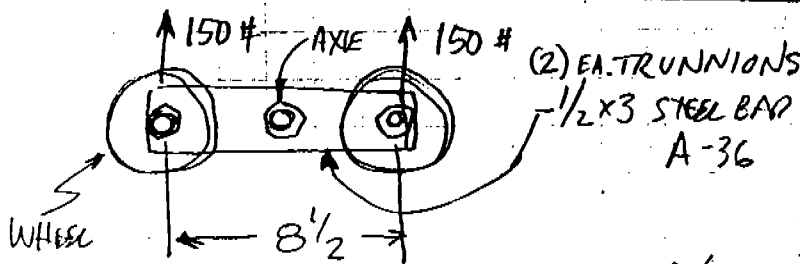

REF. c, pg. 371

$$I = \frac{bd^3}{12} = \frac{.5(3)^3}{12} = 1.12 \text{ in}^4$$

$$\sigma = \frac{M_c}{I} = \frac{(2)(150)(4.25)(1.5)}{1.12} = 1,707 \text{ PSI}$$

FACTOR OF SAFETY

18,000 17.54 OKAY



2695 SPRINGMILL RD. • MANSFIELD, OH 44903
 (419) 747-4708 FAX (419) 747-4715

ENGINEERING ANALYSIS		
CENTRAL PARK SERIES RIDE		
Pg. 9 of 12	06-10-96	TM

16.0) FRONT AXLE (A-36 STEEL) REF. C, Pg. 372

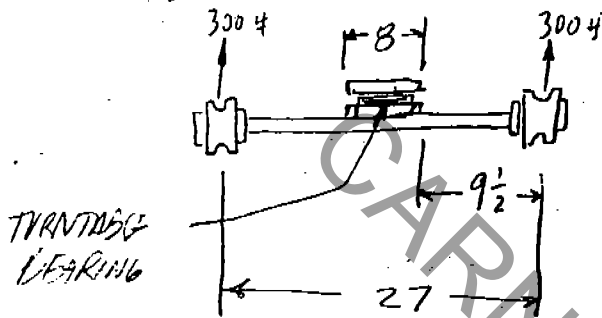

$M = 300 \text{ LBS.} \cdot (9\frac{1}{2}) \text{ IN.} = 2,850 \text{ LB.-IN.}$

$I = .055 d^4 = .197 \text{ IN.}^4$

$d = 1\frac{3}{8} \text{ D.}$

$$\sigma = \frac{M_c}{I} = \frac{(2,850)(.687)}{.197} = 9,938 \text{ psi.}$$

FACTOR OF SAFETY

$$S = \frac{18,000}{9,938} = 1.81 \text{ OKAY}$$

17.0) FRONT TURNTABLE BEARING

5" DIA. RATED @ 4,950 LBS.

TOTAL FRONT AXLE LOAD = 600 LBS.

FACTOR OF SAFETY

$$S = \frac{4,950}{600} = 8.25 \text{ OKAY}$$



2695 SPRINGMILL RD. • MANSFIELD, OH 44903
 (419) 747-4708 FAX (419) 747-4715

ENGINEERING ANALYSIS		
CENTRAL PARK SERIES RIDE		
pg. 10 OF 12	06-10-96	TJM

18.0) TURNABLE MOUNTING PINS - FRONT

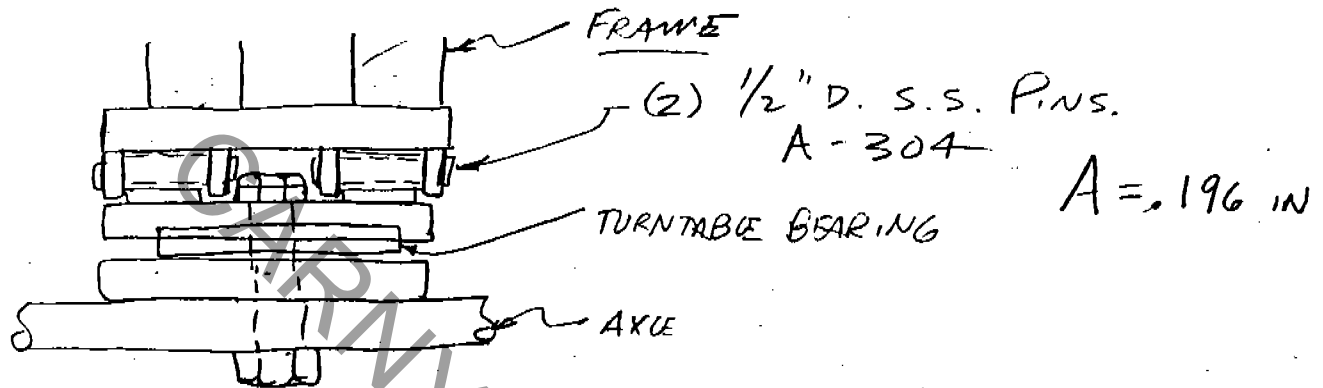

$A = .196 \text{ IN}$

$\sigma = \frac{P}{A} = \frac{600}{(4)(.196)} = 764 \text{ psi.}$

FACTOR OF SAFETY

$\delta = \frac{17,500}{764} = 22.9 \text{ OKAY}$

19.0) FRAME RAILS

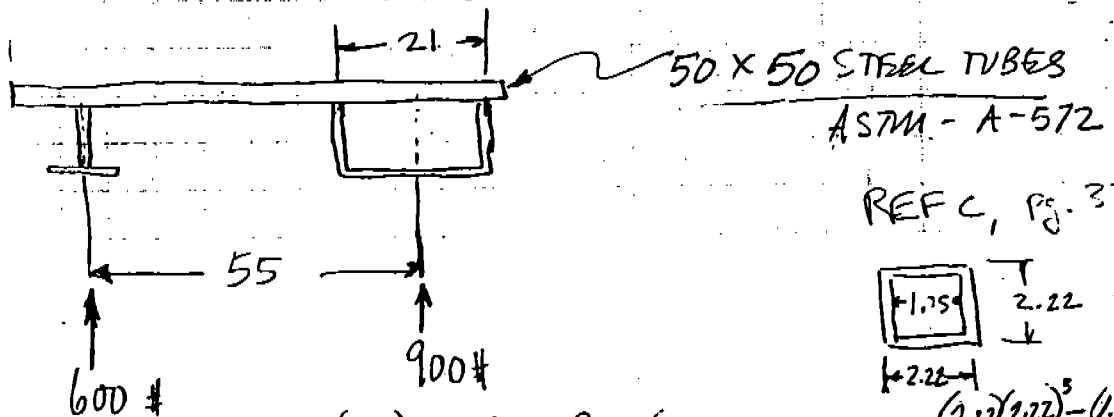

$I = \frac{(2.22)(2.22)^3 - (1.75)(1.75)^3}{12} = 1.24 \text{ IN}^4$

$M = \left(\frac{600}{2}\right)(27.5) + \frac{900}{2}(27.5) = 20,625 \text{ IN.LB.}$

$\sigma = \frac{M_c}{I} = \frac{(20,625)(1.11)}{1.24} = 18,425 \text{ psi.}$



2695 SPRINGMILL RD. • MANSFIELD, OH 44903
(419) 747-4708 FAX (419) 747-4715

ENGINEERING ANALYSIS		
CENTRAL PARK SERIES RIDE		
pg. 11 of 12	06-10-76	TJK

FACTOR OF SAFETY

$$C = \frac{25,000}{18,425} = \underline{1.36} \quad \underline{\underline{OKAY}}$$

20.0) SEAT BELTS

ASSUME A 150# PASSENGER OR
1/4 OF THE VEHICLE WEIGHT CAPACITY.

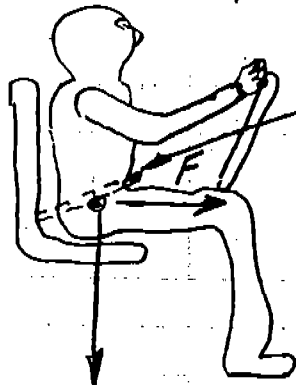

SEAT BELT TEST
STRENGTH = 375 LBS.

ASSUME $F = 50$ LBS. OR 1/3
OF PASSENGER WEIGHT.

ASSUME MAX. DECELERATION
FORCE OF 2g's FROM ACCIDENT
IMPACT BECAUSE OF LOW
SPEEDS AND BUMPER CONSTRUCT.

$$\therefore F = (2)(50) = 100 \text{ LBS.}$$

FACTOR OF SAFETY

$$C = \frac{375}{100} = \underline{3.75} \quad \underline{\underline{OKAY}}$$



2695 SPRINGMILL RD. • MANSFIELD, OH 44903
(419) 747-4708 FAX (419) 747-4715

ENGINEERING ANALYSIS		
CENTRAL PARK SERIES RIDE		
pg. 12 of 12	6-13-96	TM

21.0) SEAT BELT ANCHORAGE

SEAT BELT IS MOUNTED WITH
(2) $5/16$ DIA. GRADE 2 BOLTS. ASSUME
EQUAL LOAD DISTRIBUTION.

$$F = \frac{100 \text{ LBS.}}{2} = 50 \text{ LBS.}$$

 FOR A $5/16$ " DIA. BOLT.
 $A = .052 \text{ IN}^2$

$$\delta = \frac{50}{.052} = 961 \text{ PSI.}$$

FACTOR OF SAFETY

$$\delta = \frac{34,500}{961} = \underline{35.8 \text{ OKAY}}$$

22.0) RESULTS

THE ANALYSIS DEMONSTRATES THAT THE CENTRAL PARK SERIES RIDE CAN SAFELY SUSTAIN THE LOADS IMPOSED WHEN OPERATED IN ACCORDANCE WITH THE MANUFACTURER INSTRUCTIONS. THIS APPLIES TO ALL THEMES OF THE RIDE UTILIZING THE SAME COMPONENTS.

CARNYTOWN.COM