

USA-ED  
3146  
(PIRATES COVE)

# KREATIVE KARTS INC

---

## KART MANUAL

---



**FOR PARTS AND SERVICE CALL**  
**1800-305-6091**

## CONTENTS

1. OWNERS RULES
2. SUGGESTED RULES
3. TOOL LIST
4. DAILY INSPECTION
5. SAMPLE DAILY CHECK SHEET
6. WEEKLY SERVICE SCHEDULE
7. ROLLBAR, BODY, AND ENGINE
8. TIRES, TUBES AND RIMS
9. STEERING SYSTEM
10. BRAKES
11. BRAKE BLEEDING PROCEDURES
12. FRONT HUBS
13. REAR HUBS
14. DRIVE BELT INSTALLATION
15. SHOULDER HARNESS

## OWNER'S CHECK LIST

1. READ ALL THE INFORMATION INCLUDED IN THIS MANUAL. PROVIDE MECHANIC WITH HONDA SHOP MANUAL.
2. GAS AND OIL ENGINE & R.D. BOX. RE: HONDA MANUAL.
3. MAKE SURE THAT KARTS ARE AS ORDERED . I) KART COLOURS, DECAL PACKAGES, ETC.
4. INSTRUCT EMPLOYEES ON FASTENING & TIGHTENING OF SEATBELTS.
5. INSTRUCT EMPLOYEES ON VISUAL & DRIVEN DAILY INSPECTIONS.
6. INSTRUCT EMPLOYEES ON CLEANING THE KARTS.
7. REPORT ANY SHIPPING DAMAGE AS SOON AS POSSIBLE TO MANUFACTURER.
8. INSTRUCT MECHANIC ON ORDER PROCEDURES. I.E.) IF P.O. IS REQUIRED OR AUTHORIZATION & PHONE NUMBERS. ROB OR PAUL TOLL FREE 1-800-305-6091.
9. IMPORTANT AFTER ONE DAYS USE, HAVE MECHANIC CHECK FRONT WHEELS AND RE-SET BEARING LOAD.
10. IF YOU HAVE ANY QUESTIONS ON OPERATION OR MAINTENANCE PLEASE CALL US.

## SUGGESTED RULES

1. MINIMUM HEIGHT REQUIREMENT AS PER KART & MANUFACTURER.
2. NO SMOKING.
3. STAY IN KART AT ALL TIMES.
4. NO BUMPING.
5. LISTEN TO TRACK EMPLOYEES AT ALL TIMES.
6. NO IN-LINE DOUBLE RIDING. (ONLY ON SIDE BY SIDE DOUBLE SEATED KART)
7. NO DRIVING WHILE UNDER THE INFLUENCE OF DRUGS OR ALCOHOL.
8. SEATBELT MUST BE FASTENED AT ALL TIMES WHILE RIDING THE KART.
9. HELMETS MUST BE WORN. (THIS VARIES AS PER INSURANCE & STATE LAWS)
10. RIDE AT YOUR OWN RISK.

## SUGGESTED TOOL LIST

AIR COMPRESSOR  
AIR GUN 3/8" DRIVE  
AIR RATCHET 3/8" DRIVE  
AIR BLOWER NOZZLE  
1/4" TO 3/4" SOCKET SET 3/8" DRIVE  
1/4" TO 3/4" COMBO WRENCH SET  
15/16" COMBINATION WRENCH  
1 1/8" SOCKET 3/8" DRIVE  
10 MM SOCKET 3/8" DRIVE  
12 MM SOCKET 3/8" DRIVE  
13 MM SOCKET 3/8" DRIVE  
17 MM SOCKET 3/8" DRIVE  
7/32" HEX HEAD SOCKET 3/8" DRIVE  
5/16" HEX HEAD SOCKET 3/8" DRIVE  
3/16" HEX HEAD SOCKET 3/8" DRIVE  
1/4", 3/32" & 5/32" ALLEN WRENCHES  
HAMMER  
NEEDLE NOSE PLIERS  
MEDIUM SIZED VICE GRIPS  
STANDARD SCREW DRIVER  
PHILIPS SCREW DRIVER  
GREASE GUN  
RUBBER Mallet  
BENCH VICE

\*\*\*\*\*OPTIONAL\*\*\*\*\*

HYDRAULIC OR ELECTRIC LIFT

## DAILY INSPECTION

GO-KARTS SHOULD BE VISUALLY INSPECTED DAILY. EACH KART SHOULD ALSO BE DRIVEN BY STAFF BEFORE YOU OPEN TO THE PUBLIC TO ENSURE THE BRAKE SYSTEM, THE STEERING SYSTEM & ACCELERATOR SYSTEM ARE ALL WORKING PROPERLY. BY ENSURING YOUR KARTS ARE IN GOOD MECHANICAL CONDITION YOU WILL PREVENT UNNECESSARY DOWN TIME DURING YOUR BUSIEST TIMES OF THE DAY, AS WELL AS RIDER & TRACK SAFETY.

### VISUAL INSPECTION SHOULD INCLUDE

- |                                |  |
|--------------------------------|--|
| INSPECTION OF TRACK & BARRIERS | <ul style="list-style-type: none"> <li>- MAKE SURE TRACK IS CLEAN</li> <li>- BARRIERS ARE SECURED PROPERLY</li> </ul>  |
| TIRES                          | <ul style="list-style-type: none"> <li>- ADD AIR IF TIRE IS LOW</li> <li>- REPLACE BADLY WORN TIRES</li> </ul>   |
| BODY                           | <ul style="list-style-type: none"> <li>- INSPECT FOR BREAKAGE</li> <li>- ALL BODY MOUNT BOLTS ARE SECURE</li> <li>- KEEP BODIES CLEAN</li> </ul>   |
| STEERING WHEEL                 | <ul style="list-style-type: none"> <li>- BE SURE NO FOAM HAS BEEN REMOVED</li> <li>- STEERING WHEEL IS NOT BENT</li> <li>- SECURELY FASTENED TO STEERING SHAFT</li> </ul>  |
| UPHOLSTERY                     | <ul style="list-style-type: none"> <li>- ENSURE NO RIPS HAVE OCCURRED</li> <li>- REPLACE ANY MISSING PLUGS</li> <li>- CLEAN WITH A VINYL PRODUCT</li> </ul>  |
| BELT TENSION                   | <ul style="list-style-type: none"> <li>- MAKE SURE BELT IS TIGHT AND NOT DAMAGED</li> </ul>  |
| ENGINE                         | <ul style="list-style-type: none"> <li>- VERY IMPORTANT CHECK &amp; DOUBLE CHECK TO ENSURE GAS CAP IS FASTENED PROPERLY &amp; TIGHT</li> <li>- NO OIL LEAKS</li> <li>- AIR FILTER IS CLEAN</li> <li>- CHECK OIL LEVELS, BOTH ENGINE &amp; R.D.</li> <li>- BOX</li> </ul> |

**NOTES:** USE A LOG SHEET TO KEEP A RECORD OF YOUR MAINTENANCE & INSPECTIONS FOR EACH KART. THIS WILL HELP ENSURE ALL CHECKS ARE BEING PERFORMED REGULARLY.

MONTH

DAILY CHECK SHEET

KART#	MON		TUE		WED		THU		FRI		SAT		SUN	
	VISUAL	DRIVEN	VISUAL	DRIVEN	VISUAL	DRIVEN	VISUAL	DRIVEN	VISUAL	DRIVEN	VISUAL	DRIVEN	VISUAL	DRIVEN
1														
2														
3														
4														
5														
6														
7														
8														
9														
10														
11														
12														
13														
14														
15														
16														
17														
18														
19														
20														
21														
22														
23														
24														
25														
26														
27														
28														
29														
30														
31														
32														
33														
34														
35														
36														
37														
38														
39														
40														
41														
42														
43														
44														
45														

CARPLYTOWN.COM

## WEEKLY SERVICE SCHEDULE

1. BRAKE SYSTEM - CHECK PEDAL FOR FIRMNESS
2. ENGINE OIL - CHANGE
3. REDUCTION BOX OIL - CHANGE
4. ENGINE AIR FILTER - REMOVE, CLEAN & REINSTALL
5. LUG NUTS & BOLTS - RE-TIGHTEN IF REQUIRED
6. THROTTLE LINKAGE - LUBRICATE
7. BELT TENSION - ADJUST IF NECESSARY
8. BEARINGS - MAKE SURE ALL BEARINGS MOVE FREELY  
- FRONT HUBS HAVE NO PLAY UP OR DOWN  
- GREASE IF NECESSARY
9. STEERING - LUBRICATE TIE ROD ENDS WITH WD40 OR  
LIKE PRODUCT
10. CLEANING - CLEAN EXCESS OIL & GREASE OFF ENGINE  
AND KART

**IMPORTANT:** THIS IS A SAMPLE OF REQUIRED MAINTENANCE. YOU MAY CHOOSE TO DO THE SERVICE DIFFERENTLY, BUT REMEMBER TO KEEP RECORDS ON ALL YOUR SERVICE TO KARTS.

REGULAR MAINTENANCE WILL SAVE YOU TIME & MONEY IN THE FUTURE. KEEP YOUR KARTS IN GOOD WORKING CONDITION AND REPLACE WORN PARTS AS SOON AS POSSIBLE TO AVOID DOWN TIME WHEN YOU ARE BUSY.

## ROLL BAR & BODY

### REMOVAL OF ROLL BAR

- UNCLIP SEATBELT FROM ROLL BAR
- USE 5/8" SOCKET & 5/8" WRENCH TO REMOVE THE 2 BOLTS, HOLDING ROLL BAR TO FRAME
- TAP CENTER SUPPORT ON ROLL BAR UP USING RUBBER Mallet

TO INSTALL REVERSE ABOVE INSTRUCTIONS

### REMOVAL OF BODY

- REMOVE ROLL BAR & SEATBELT PRIOR TO BODY
- USE 5/16" HEX HEAD SOCKET AND REMOVE BODY BOLTS
- USE 2 PEOPLE AND LIFT BODY UP & SLIGHTLY BACK TO GET LEG OPENING BY STEERING WHEEL

TO INSTALL REVERSE ABOVE INSTRUCTIONS

## ENGINE

USE ONLY RECOMMENDED OIL IN YOUR HONDA ENGINES TO DO MAJOR & MINOR REPAIRS ON ENGINE YOU ONLY REQUIRE 10 MM SOCKET = RD HOUSING & VARIOUS. 12 MM SOCKET = MUFFLER & R.D. BOX. 13 MM SOCKET = DRIVE GEAR BOLT. 17 MM SOCKET = R.D. BOX DRAIN PLUG. 3/4" SPARK PLUG SOCKET = PLUGS

FOR SERVICING OF ENGINE USE HONDA SHOP MANUAL PROVIDED WITH KARTS

## TIRES, TUBES & RIMS

### HOW TO ASSEMBLE TIRES, TUBES & RIMS

- PLACE TUBE IN TIRE
- ADD A LITTLE AIR TO TUBE
- PUT VALVE STEM OF TUBE THROUGH RIM HALF WITH HOLE PUNCHED ON THE SIDE
- SET RIM INTO TIRE, MAKE SURE TUBE IS NOT PINCHED BETWEEN RIM & TIRE
- PUT BACK HALF OF RIM ONTO A SPARE HUB WHICH IS LOCKED IN A VICE
- PLACE TIRE ASSEMBLY ON TOP OF RIM IN VICE
- BOLT TOGETHER USING 3 5/16" BOLTS & NUTS WITH LOCK WASHER IN BETWEEN NUT & RIM. USE 1/2" SOCKET AND WRENCH TO TIGHTEN TOGETHER

NOTE: BE SURE TUBE IS NOT PINCHED BETWEEN THE 2 RIM HALVES PRIOR TO TIGHTENING

#### - INFLATE TO RECOMMENDED PRESSURE

340 X 300 X 5 = 30 TO 32 LBS

410 X 350 X 5 = 30 TO 32 LBS

12 X 400 X 5 = 30 TO 32 LBS

11 X 600 X 5 = 30 TO 32 LBS

16 X 16.5 X 8 = 30 TO 32 LBS

THESE PRESSURES MAY VARY DUE TO TRACK & WEATHER CONDITIONS

**IMPORTANT: ALWAYS HAVE SPARE TIRES READY TO INSTALL**

## STEERING SYSTEM

### STEERING ALIGNMENT

1. POSITION PITMAN ARM SO IT IS CENTER ON KART.
2. DRAW A CHALK LINE ON CENTRE OF EACH TIRE & TAKE MEASUREMENT FROM LINE TO LINE.
3. REVOLVE TIRE 180 DEGREES AND TAKE MEASUREMENT AGAIN.
4. THIS MEASUREMENT SHOULD BE WITHIN 1/8" OF FIRST MEASUREMENT.

### CHANGING ALIGNMENT

1. ESTABLISH WHICH TIRE IS TOWED IN OR OUT. CHECK PARALLEL BETWEEN TIRE & FRAME.
2. REMOVE TIE ROD END FROM SPINDLE USING 3/4" SOCKET & WRENCH.
3. LOOSEN JAM NUT ON TIE ROD, TURN ROD END IN TO RELIEVE TOE OUT OR TURN ROD END OUT TO RELIVE TOE IN.
4. RETAKE MEASUREMENTS AS ABOVE.

TOP VIEW STEERING ASS'Y.

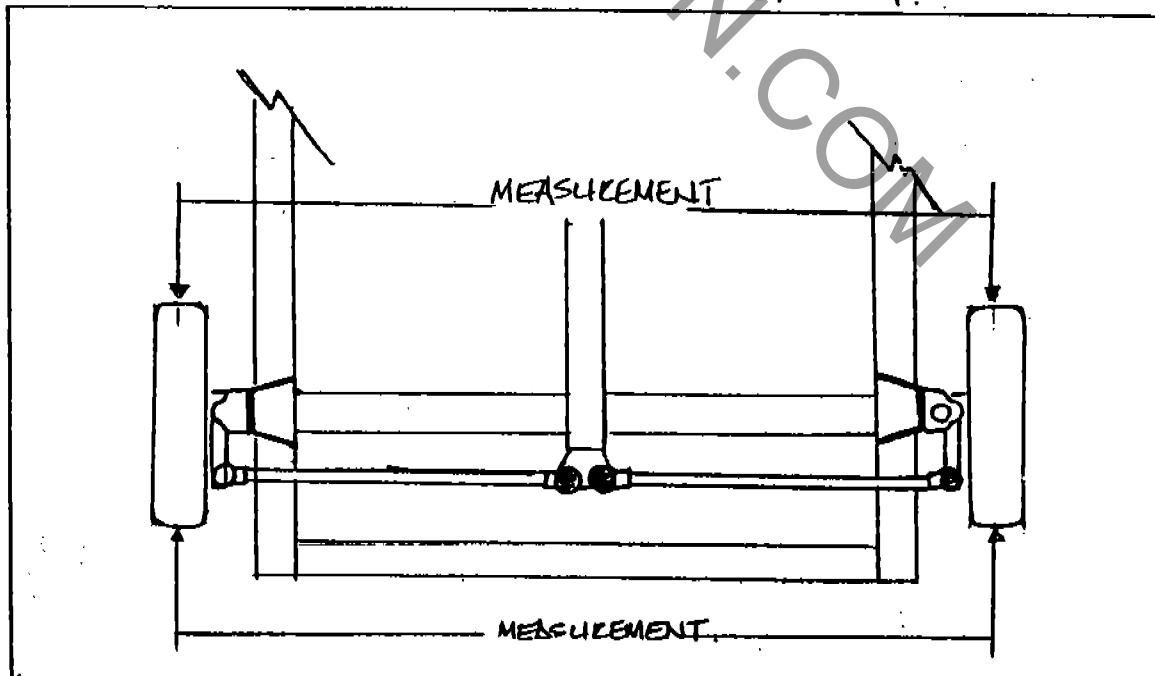

## BRAKE SYSTEM

### BRAKE PAD GAP ADJUSTMENT

BY USING A 1/4" ALLEN WRENCH YOU CAN ADJUST THE PAD IN AND OUT AS REQUIRED. A LITTLE DRAG ON THE PAD IS ADEQUATE.

### BRAKE PAD REPLACEMENT

TO REPLACE PADS USE 3/16" ALLEN WRENCH TO UNSCREW INNER SOCKET HEAD CAP SCREW

### THINGS TO CHECK

- NO AIR IN LINES
- MAKE CERTAIN GRUB SCREWS ON BRAKE DISC ARE TIGHT. IF YOU REMOVE SCREWS USE LOCK TIGHTS ON SCREWS WHEN REPLACING
- MAKE SURE RODS ARE NOT RUBBING ON KART BODY

CAMPY TOWN.COM

## BLEEDING INSTRUCTIONS

BE SURE ALL HYDRAULIC CONNECTIONS ARE SECURE. NEVER USE TEFLON TAPE TO SEAL THE FITTINGS IN THE CASTINGS. AN APPROPRIATE TEFLON PASTE LIKE THAT USED FROM THE MANUFACTURER IS RECOMMENDED. THE HIGH PRESSURE TUBING SHOULD BE INSERTED COMPLETELY INTO THE CAP AND FERRULE. FROM FINGER TIGHT, THE FITTING CAP SHOULD BE TIGHTENED TWO TURNS. THIS SHOULD LEAVE A GAP OF ABOUT .050" BETWEEN THE CAP AND THE HEX PART OF THE FITTING BODY.

REMOVE THE FILLER PLUG FROM THE MASTER CYLINDER TOP AND FILL RESERVOIR WITH DOT 5 SILICONE BRAKE FLUID ONLY 1 STROKE THE MASTER CYLINDER LEVER ARM A FULL STROKE AND OPEN THE BLEED SCREWS ON THE CALIPER FOR ABOUT TWO SECONDS THEN CLOSE. NOW WAIT APPROXIMATELY TEN SECONDS. THIS ALLOWS TIME FOR THE FLUID IN THE RESERVOIR TO TRANSFER INTO THE BORE OF THE MASTER CYLINDER. REPEAT THE PROCESS OF STROKING THE MASER CYLINDER AGAIN, OPEN AND CLOSE THE BLEED SCREWS THE SAME AS BEFORE. WAIT AGAIN. CONTINUE THIS PROCEDURE UNTIL A MORE FIRM PEDAL IS REALIZED (DEPENDING ON THE LENGTH OF LINE USED, THIS WILL BE PROBABLY FOUR TO SIX TIMES).

AFTER A REASONABLE PEDAL IS FIRMING UP, TAKE SHORTER STROKES OF THE MASER CYLINDER WITH THE BLEED SCREWS OPEN SO AS TO ALLOW ONLY A SHORT SPURT OF BRAKE FLUID TO ESCAPE AT A TIME. FOR THE FINISHING PROCESS THE BRAKE PEDAL SHOULD BE HELD DOWN FIRMLY BEFORE OPENING THE BLEED SCREWS TO PURGE AS MUCH AIR WITH THE ESCAPE OF FLUID AS POSSIBLE.

CHECK ALL HYDRAULIC CONNECTIONS FOR ANY POSSIBLE FLUID LEAKS.

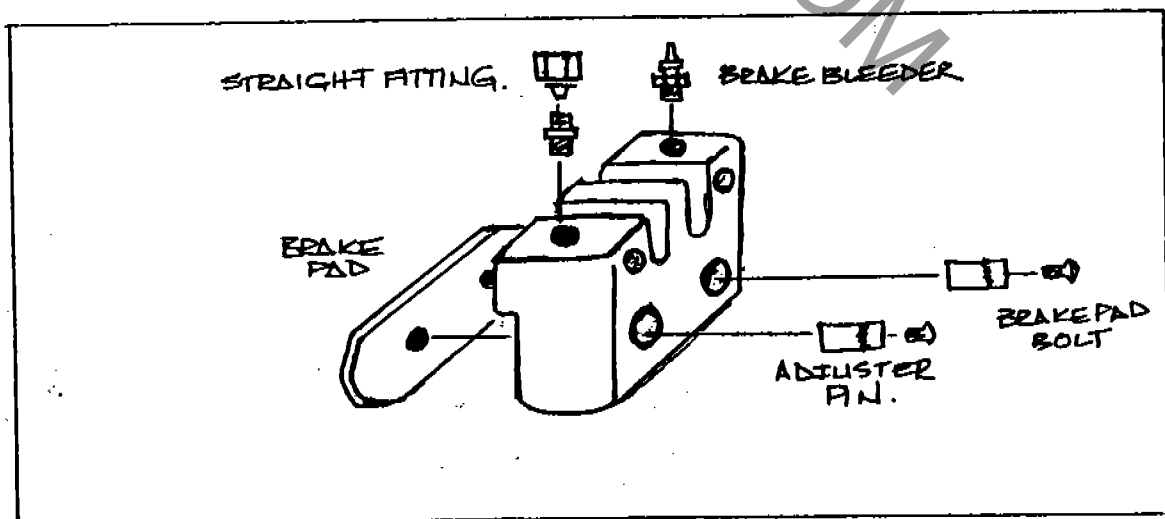

## WHEEL HUBS

### FRONT HUB INSTALLATION

1. BACK BEARINGS WITH GREASE.
2. PREASSEMBLE HUB WITH REARING RACE, REAR SEAL AND BEARINGS.
3. PLACE ASSEMBLY ON SPINDLE
4. SCREW CASTLE NUT ON SPINDLE AND TIGHTEN ASSEMBLY.
5. MAKE SURE YOU DO NOT OVER TIGHTEN CASTLE NUT. BEARING SHOULD MOVE FREELY WITH NO WOBBLE IN THE HUB UP OR DOWN IF YOU LIFT ON IT.

**IMPORTANT: AFTER CHANGING BEARINGS YOU NEED TO RE-SET BEARING LOAD AFTER 10 TO 15 HOURS USE.**

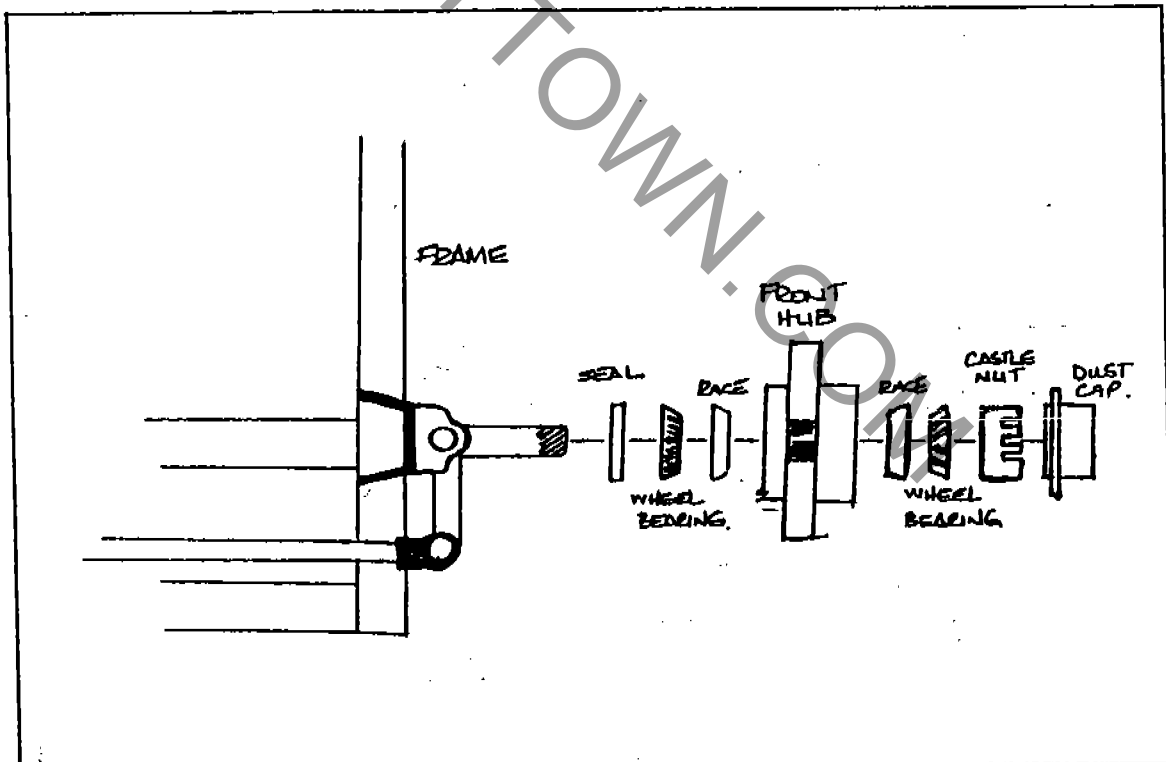

**WHEEL HUBS****INSTALLATION REAR HUB**

1. PREASSEMBLE HUB TO BUSHING BY INSERTING BOLTS THROUGH LOCK WASHER AND THROUGH UNTHREADED HOLES IN BUSHING AND SCREW INTO HUB LOOSELY.
2. PLACE HUB ASSEMBLY ON AXLE AT DESIRED LOCATION AND INSERT KEY STOCK.
3. TIGHTEN 3 BOLTS ON ASSEMBLY, THIS WILL DRAW THE HUB UPON THE BUSHING AND FASTENING IT TIGHTLY TO AXLE.

**REMOVAL OF REAR HUB**

1. REMOVE 3 BOLTS HOLDING HUB & BUSHINGS TOGETHER.
2. RE-INSERT BOLTS IN THREADED HOLES ON BUSHING.
3. SCREW BOLTS IN UNTIL HUB IS BACKED OFF, BUSHING ASSEMBLY CAN NOW BE REMOVED.

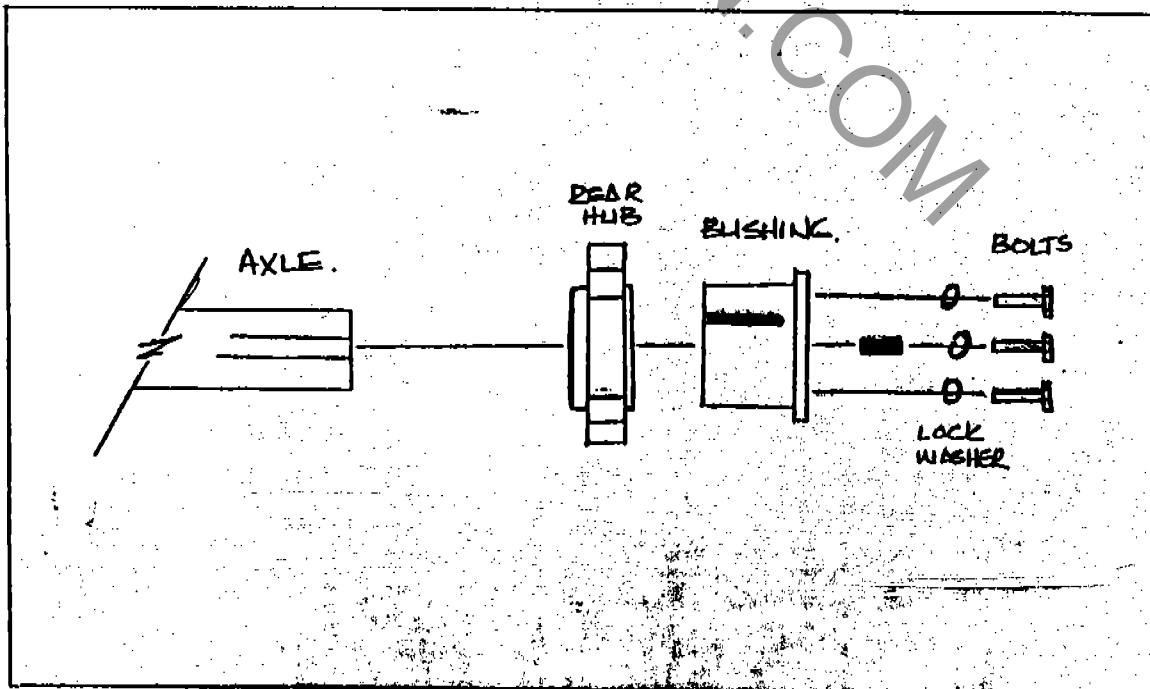

**DRIVE BELT****REMOVAL & INSTALLATION**

1. REMOVE TIRE & RIM ASSEMBLY.
2. LOOSEN NUTS OFF ENGINE MOUNT PINS AT REAR OF KART. THIS WILL LOOSEN BELT.
3. REMOVE DRIVE BELT FROM BOTTOM GEAR, AND THEN TOP GEAR.
4. PLACE NEW DRIVE BELT ON TOP GEAR AND THEN ON BOTTOM GEAR.
5. MAKE SURE BELT IS ALIGNED PROPERLY ON GEARS AND TEETH ARE MESHING PROPERLY.
6. RE-TIGHTEN NUTS ON ENGINE MOUNT PINS UNTIL BELT IS TIGHT.
7. SPIN HUB TO ENSURE BELT RIDES ON GEARS PROPERLY.

CARPARTYTOWN.COM

## SEATBELT AND SHOULDER HARNESS

### ADJUSTING

1. HAVE CUSTOMER SLIP ARMS THROUGH SHOULDER RESTRAINTS AS THEY ARE ENTERING THE GO KART.
2. WHEN CUSTOMER IS SEATED THEY SNAP BUCKLE INTO PLACE.
3. TIGHTEN LAP BELT UNTIL SNUG AROUND WASTE.
4. PULL DOWN ON GREEN TABS OF SHOULDER RESTRAINT UNTIL SNUG AGAINST UPPER BODY OF CUSTOMER.
5. BE SURE CUSTOMER KNOWS NOT TO REMOVE SEATBELT WHILE RIDING IN THE GO KART AND TO STAY IN THE KART AT ALL TIMES.

### RELEASING

1. TO RELEASE CUSTOMER FROM SEATBELT PULL UP ON THE RED TABS OF THE SHOULDER RESTRAINT.
2. UNBUCKLE LAP BELT USING THE PUSH BUTTON.

**IT IS VERY IMPORTANT FOR STAFF TO ENSURE CUSTOMERS SEAT BELT IS PROPERLY ADJUSTED AND WORN TO PREVENT INJURIES.**

## GO-KART OPERATIONS

1. NO PERSON SHALL BE ALLOWED TO OPERATE AN ADULT (BLACK) VEHICLE IF THEY ARE UNDER THE AGE OF 11 AND/OR UNDER THE HEIGHT OF 54 INCHES.
2. NO PERSON SHALL OPERATE A JUNIOR VEHICLE IF THEY ARE UNDER THE AGE OF 8 AND/OR UNDER THE HEIGHT OF 48 INCHES.
3. NO PERSON WHO EXCEEDS THE AGE OF 8 AND/OR IS TALLER THAN 48 INCHES WILL BE ALLOWED TO OPERATE A KIDDIE STYLE VEHICLE.
4. ALL VEHICLES THAT ARE OPERATED ON THE TRACK AT THE SAME TIME WILL HAVE IDENTICAL BODY STYLES AND PARTS. (IN OTHER WORDS, DO NOT MIX STYLES OF VEHICLES ON THE TRACK AT THE SAME TIME.)
5. EVERY SECTION OF THE TRACK SHALL BE MONITORED AT ALL TIMES BY AN EMPLOYEE OF PIRATE'S COVE, INC.
6. TRACK SHALL BE KEPT FREE FROM OIL AND FUEL SPILLS. ANY VEHICLE THAT HAS SUCH A LEAK WILL BE REMOVED FROM THE TRACK IMMEDIATELY AND FIXED BY THE MECHANIC, ANY AREA OF THE TRACK THAT HAS OIL AND/OR GAS WILL BE CLEANED COMPLETELY BEFORE THE TRACK IS RE-OPENED.
7. HELMETS AND GOGGLES MUST BE MADE AVAILABLE TO ANY CUSTOMER THAT WISHES TO USE THEM. THESE ARE KEPT IN THE SNACK-BAR AREA WHERE IT IS CLEAN.
8. ANY PERSON WHO HAS HAIR OF A LONG LENGTH THAT COULD BECOME ENTANGLED IN THE MOVING PARTS OF THE VEHICLES WILL NOT BE ALLOWED TO OPERATE THE VEHICLE UNTIL THE HAIR IS RESTRAINED.
9. ALL LOOSE CLOTHING SHALL BE SECURED SO AS NOT TO INTERFERE WITH THE OPERATION OF THE VEHICLE.
10. INSTRUCTIONS SHALL BE GIVEN TO EACH AND EVERY RIDE OPERATED THAT WILL INCLUDE AT LEAST THE FOLLOWING:
  - SMOKING IS NOT PERMITTED IN OR AROUND THE PIT AREA.
  - CUSTOMERS MUST REMAIN SEATED AT ALL TIMES UNTIL TOLD TO GET UP BY THE DESIGNATED TRACK OFFICIAL.
11. ALL LIGHTS THAT ARE IN PLACE ON THE TRACK AND SURROUNDING AREA WILL BE LIT DURING ALL NIGHT OPERATION HOURS.
12. ALL CUSTOMERS WILL BE GIVEN SAFETY PROCEDURES EVERY RIDE.
13. ALL RULES WILL BE ENFORCED AT ALL TIMES. NO EXCEPTIONS.
14. EMERGENCY PROCEDURES WILL BE EXPLAINED TO EVERY RIDE.
15. ANY AND ALL ACCIDENTS WILL BE REPORTED TO THE MANAGER ON DUTY.
16. ALL RIDES WILL BE CONTROLLED BY THE DESIGNATED TRACK "BOSS" IN CHARGE OF THE "PIT CONTROL".