

MFB: KMG

RIDE: FIREBALL / Frisbee / Beach  
Party

# FIREBALL MANUAL

CARNYTOWN.COM

## **CONTENTS**

<b>Chapter 1</b>	<b>General information</b>
<b>Chapter 2</b>	<b>Safety regulations</b>
<b>Chapter 3</b>	<b>User-restrictions</b>
<b>Chapter 4</b>	<b>Inspection and maintenance attraction</b>
<b>Chapter 5</b>	<b>Machine operation</b>
<b>Chapter 6</b>	<b>Run cycles</b>
<b>Chapter 7</b>	<b>Setting up the attraction</b>
<b>Chapter 8</b>	<b>Dismantlement of the attraction</b>
<b>Chapter 9</b>	<b>Ordering spare parts</b>
<b>Chapter 10</b>	<b>Hydraulic scheme</b>
<b>Chapter 11</b>	<b>Electrical scheme</b>
<b>Chapter 12</b>	<b>Emergency stop</b>
<b>Chapter 13</b>	<b>Technical specifications of the trailers</b>
<b>Chapter 14</b>	<b>Technical specifications of the attraction</b>
<b>Chapter 15</b>	<b>Spare parts list Dolly</b>
<b>Chapter 16</b>	<b>Addresses</b>

## CHAPTER 1 General Information

These operation instructions for the "FRISBEE" have been composed for the user as well as for the owner of the attraction. It is absolutely imperative that these operation instructions are being read as well as understood in order to use the "FRISBEE" in a safe and optimal way.

### Description of the machine

The "FRISBEE" attraction is installed on two trailers. The "FRISBEE" knows a pendulum motion as well as a rotary motion.

The "FRISBEE" consists of a frame, built of two trailers and four masts, which have been fixed together on top, whereas the pendulum is fixed in between them. At the bottom of the pendulum the gondolas are fixed, crosswise rotating. The gondolas seat 24 persons. A shoulder bracket is being used as a safety device for the passengers.

CARNYTOWN.COM



## **CHAPTER 2 Safety regulations**

See to it that the attraction is in perfect order. A disorderly operating environment leads to accidents.

Take the environmental influences into account. Don't leave electrical tools outside lying in the rain. Be sure that electrical connections are well closed.

Don't allow unauthorized persons to go near the attraction during operation.

Don't allow unauthorized persons near the attraction during the setting up and/or the dismantlement.

Put away the material that is not to be used before the attraction is being operated.

Use the tools correctly.

Make sure the electrical connections are in order.

Maintain the attraction properly.

Take care that no unauthorized persons can go underneath or on the attraction while setting it up or during dismantlement or operation.

Be sure to have a safe operating environment when you are working at the attraction.

Dismantle the attraction correctly.

Take care passengers can enter or leave the attraction safely. Take care the platform and the fencing is fixed correctly.

Be sure you have sufficient personnel in order to guarantee a safe operating environment. There should always be 1 person available at the control box during operation. At least 1 person should be available at the entrance/exit during operation.

Be sure you have a good survey while operating the machine.

Don't allow more than 1 person per seat and 4 persons per gondola and see to it that 24 persons maximum are in the whole attraction.

The gondolas have been designed in such a way that each and every person is clamped by a separate bracket. Take care that the passengers are well locked by means of the shoulder bracket.

It is not allowed to transport persons on the brackets. This could lead to grievous bodily harm.



**CHAPTER 3. User-restrictions.**

The following instructions should be let known to the public at a clear spot:

Persons under 1.22 m not admitted.

No eating or drinking while in the attraction.

No loose articles in the attraction.

No persons under medical treatment or suffering from back- or neck symptoms.

No pregnant persons.

Only 4 persons per gondola.

The operator has to see to it that persons ignoring the regulations above, should be forbidden to use the attraction.

CARINYTOWN.COM

- L) Check the joints of the floor cylinders.

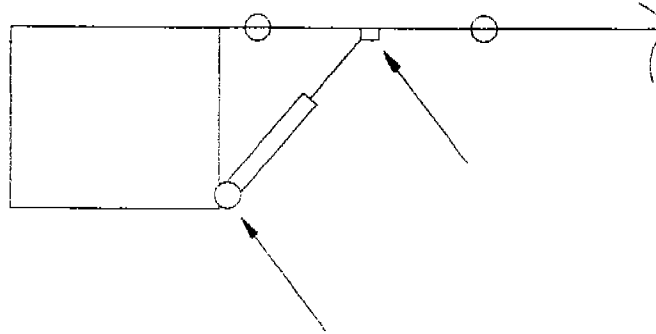

- M) The cylinders should move gradually, not with jolts. When necessary, the cylinders can be adjusted eventually.
- N) Check the speeds of the attraction:  
 - Max. angular movement  $\sim 120^\circ$  to the right and to the left.  
 - Gondola speed - 8 revolutions/min.
- O) Check the oil level in the tank. The attraction never should be operated when the oil level in the tank is to low.
- P) Check oil filter.
- Q) Check the electrical control box to be sure that the circuit breakers (earth leakage switches) function. During the "test run" you should check the functioning of the control lights.
- R) Check the main current cable and every other cable for damages. Damaged cables should be replaced.
- S) Make sure that all earthing points and earth leakage switches are in order and connected correctly. Damaged parts should be replaced immediately.
- T) Check if the lubricating points have in fact been lubricated.
- U) Check the hydraulic system for leakage. When a leakage has been found it should be repaired immediately.

### GREASING-SCHEME

Item nr.	Description	lubricating/changing interval	lubricate while setting up	sort of oil/grease	number
01	mast joint	1 * week	yes	EP2-bearing grease	4
02	lifting cylinder		yes	EP2-bearing grease	2
03	lifting cylinder		yes	EP2-bearing grease	2
04	parallelogram/locking cylinder		yes	EP2-bearing grease	12
05	hinge free arm	1 * week	yes	EP2-bearing grease	2
06	hinge points floor	daily		EP2 -bearing grease	8
07	hinge points transverse frame	1 * week	yes	EP2-bearing grease	4
08	hinge points floor cylinders	daily		EP2-bearing grease	8
09	Bearing	daily		EP2-bearing grease	8
10	clutches		yes	EP2-bearing grease	2
11	gear reducer	1 * year		Spartan EP150 Esso	2
12	hydraulic oil and filter	1 * year		ISO VG 46	2
13	Bearing	daily		EP2-bearing grease	4
14	gear reducer	1 * year		Spartan EP150 Esso	1

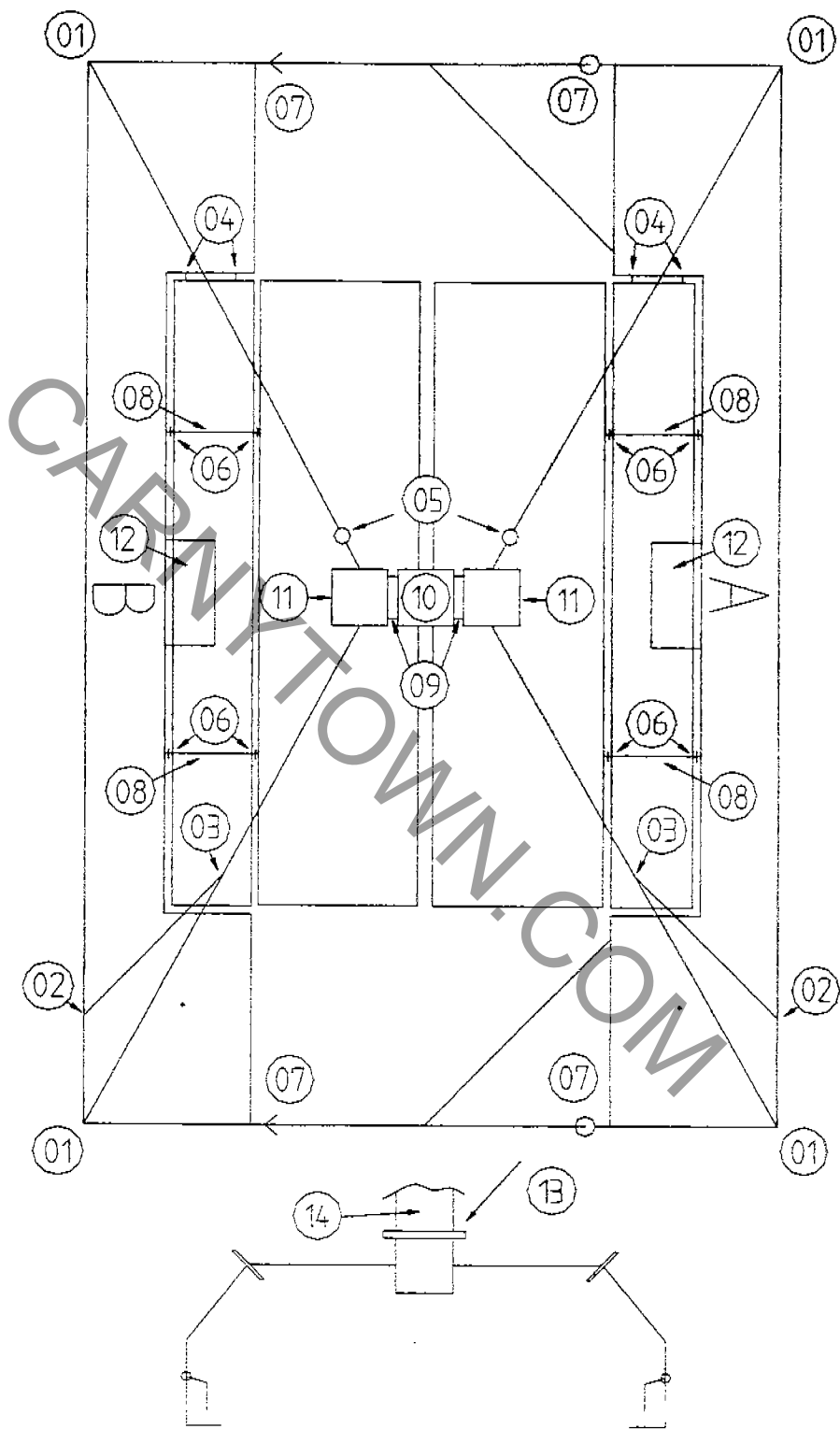



## CHAPTER 5 Operation

Connect main current cable.

Check phase sequence.

Red control light illuminates: phase connected wrong way, change phase.

Green control light illuminates: phase connected correctly.

Connect control box.

Pull out emergency stop.

Rotor installation and the small Frequency Inverter.

On the operating panel you may find the following buttons:

- 1) **Start**  
This button starts the attraction. After pushing this button, the rotor will start turning around (speed depending on position potentiometer) and the arm will start swinging at 25 % of the capacity.
- 2) **Stop**  
After pushing this button the swinging arm and the rotor will come to a standstill as fast as possible. After they both have come to a standstill the floor will be lifted. As soon as the floor has reached the correct height, the safety brackets can be opened.
- 3) **25%**  
When this button is pushed the attraction will start at 25% of the capacity. (Start function must be excited though).
- 4) **50%**  
When this button is pushed the attraction will start at 50% of the capacity (Start function must be excited though).
- 5) **100%. Blue control light will illuminate.**  
When this button is pushed the attraction will start at 100% of the capacity. (start function must be excited though). As soon as the attraction has reached a 100% speed the control will automatically shift down to a 50% capacity.
- 6) **Emergency button**  
When this button is pushed the swinging arm and the rotor will come to a standstill. Both the rotor and swinging arm will come to a standstill without applying the brakes, which will take longer to come to a hold. Having come to a hold the floor will stay in the lower position. Safety brackets will stay closed.
- 7) **Potentiometer**  
With the potentiometer the speed of the rotor can be adjusted. The maximum speed to be adjusted is 15 revolutions per minute.
- 8) **Opening/closing the brackets**  
With this button the brackets are operated. As soon as the brackets have been closed the green control light on the operating panel will illuminate and the attraction can be activated by means of the start button.

At the control box you may find the following control lights:

Blue control light: 100% capacity switched on.

Red control light: Malfunction.



If this light starts illuminating you should bring the attraction to a standstill and repair the defect. When repaired, you can start the attraction again.

CARNYTOWN.COM



## **CHAPTER 6 Run cycles**

As soon as passengers are entering the attraction, the user should be absolutely sure that the following stipulations have been complied with, before the attraction is been started as well as while the attraction is running.

There should be no more than 24 passengers per run.

Each and every gondola should be inspected very carefully, making sure that the passengers are seated correctly and that the brackets have been closed properly and the lock of the brackets are pinned correctly.

At each gondola 4 control lamps have been installed, which control the locking of the brackets independently.

When the bracket is pinned correctly, the control light illuminates..

When all brackets are pinned correctly and the last control light illuminates, they all will finally extinguish after a few seconds and the attraction can be started.

**While the attraction is running it is not allowed to have persons on the trailers.**

Start the attraction.

While the attraction is running you should watch it closely.

When the run is over, you should stop the attraction and open the brackets when the attraction stands still completely.

As soon as the brackets are opened you should have the passengers leave the gondolas and help them if necessary. Only when all passengers have left the platform you should open the gates and allow new passengers to enter the attraction.

## CHAPTER 7 Setting up the attraction

- Take care that the attraction always is set up on a hard and flat soil.
- Always check if there is enough space for the attraction.
- Use wooden filling blocks of good quality, dimensions at least 1000 x 1000 x 40 mm underneath the support pyramids.
- Roll out the trailer cable completely.
- While setting up the attraction no unauthorized people are allowed in the proximity of the attraction.

### SETTING UP

A= back trailer

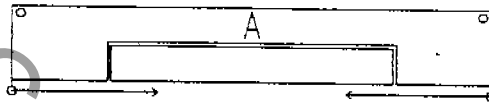

B = front trailer

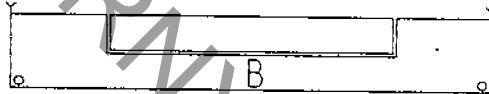

1. Place the back trailer on a flat and hard soil. Place the support pyramids. Uncouple the truck.



2. Release the air control at the dolly-set (blue button). When available, the steering ax can be adjusted now.

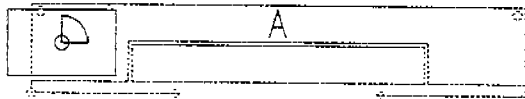

3. **Open transverse frames.**

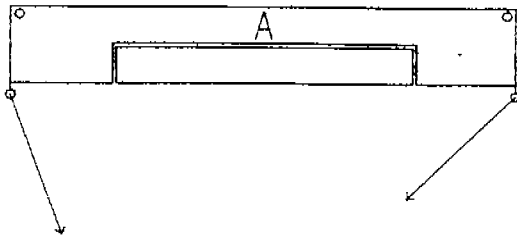

4. **Place the front trailer at approx. 4 m from the back trailer**

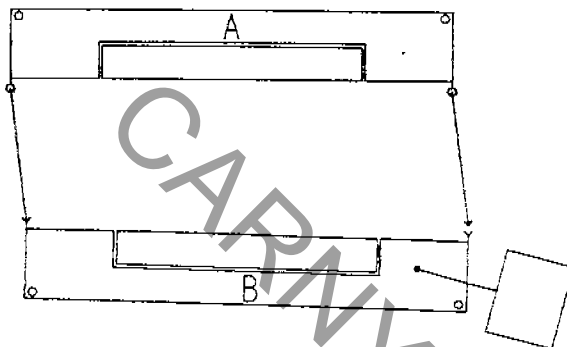

5. **Minimize the difference in height by means of the air control.**  
 6. **Now first of all put both pins into the back transverse frame.**

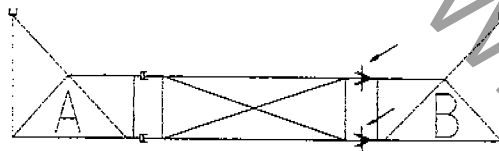

7. **Put both pins now into the front transverse frame. Move the truck max. 0.5 m.**  
 8. **Put the support pyramide underneath the front trailer.**  
 9. **Put the shores in place and fix the pins with a split pin.**

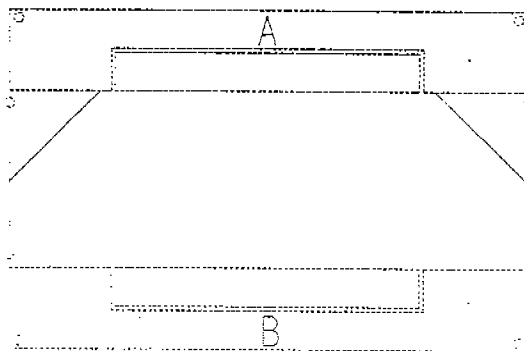

10. Uncouple the truck of trailer B.
11. Turn the controlled shaft of trailer B.

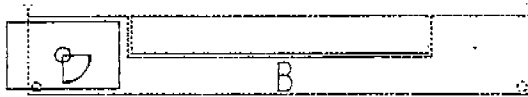

12. Connect the voltage at the electrical panel and start the hydraulic units.
13. Place two pyramides underneath the corners of the trailers (to the front). Watch very carefully where you place them in connection with the shores.



14. Have the two cylinders extending in order to get the support pyramides free. Take them away and move them to the back of the trailers.

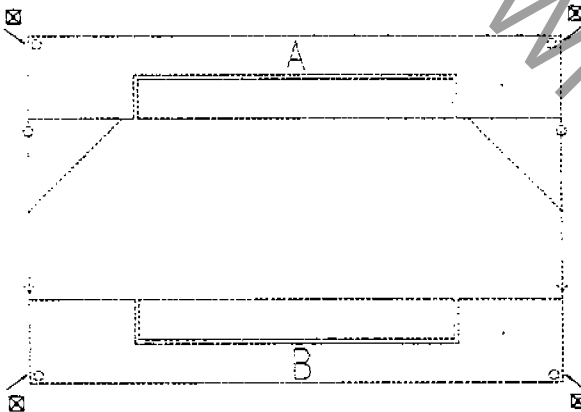

15. Now level the attraction by means of the cylinders. The cylinders should be extended 0,5 m max. when the attraction is running.

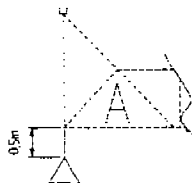

16. Remove the support from the logo between swivel floor and logo.
17. Put the front parts upright and lock them. When necessary, use shores.

18. Put the linking floor into place.

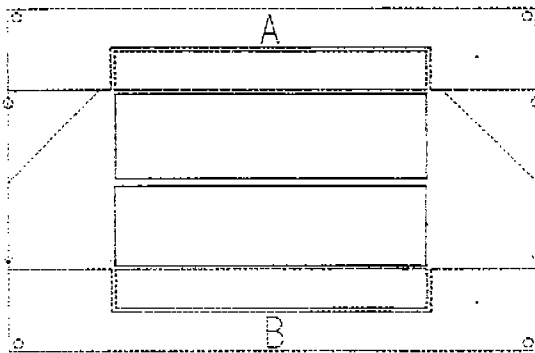

19. Fill the trailers with water. Take care: When the temperature is approx. 0° the trailers should be warmed up to avoid freezing, or use antifreeze.

20. Unfold the floors by means of the winches.

21. Put the supports into place according to following sketch.

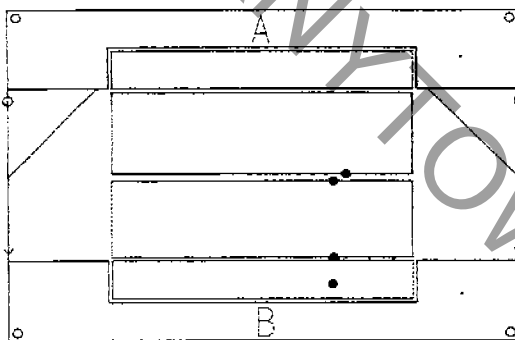

22. Move the gondolas to their place on the floor.

23. Put the plastic plates on the floor above the supports.

24. Remove the transport support of the swing arm.

25. Drive the swing arm halfway to the floor, above the supports.

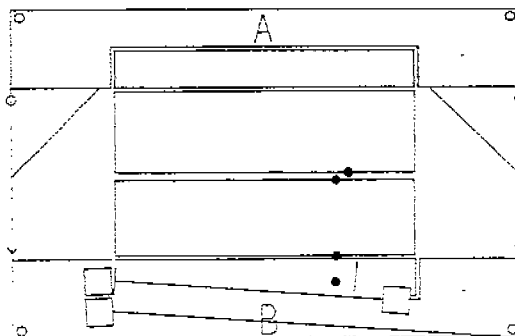

26. Open the hydraulic valve on hydro unit (trailer B) of the large setting up cylinder.

27. Have the main arm (trailer B) go to the center by means of extending the large setting up cylinder.

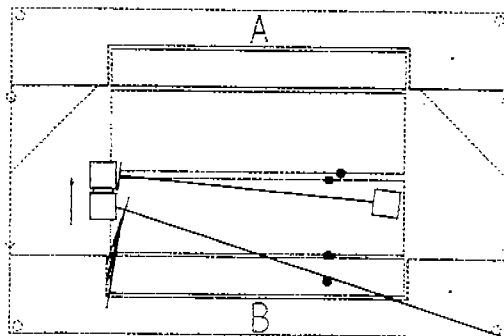

28. Open the hydraulic valve on hydro unit (trailer A) of the large setting up cylinder.

29. Send the main arm (trailer A) to the center by means of extending the large setting up cylinder.

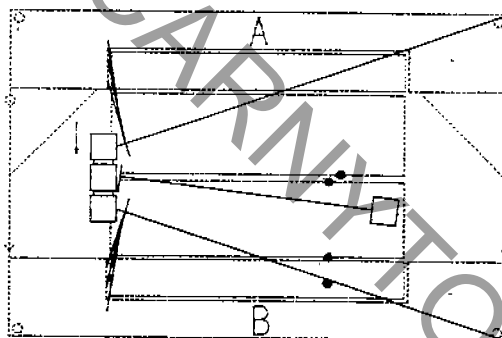

30. Connect the top edges by means of bolts. Use a torque wrench. The tightening moment is 400 Nm. Screw home crosswise.

31. Drive the swing arm to the center of the floor. Connect the bolts of the swing arm with a tightening moment of 400 Nm. Screw home crosswise.

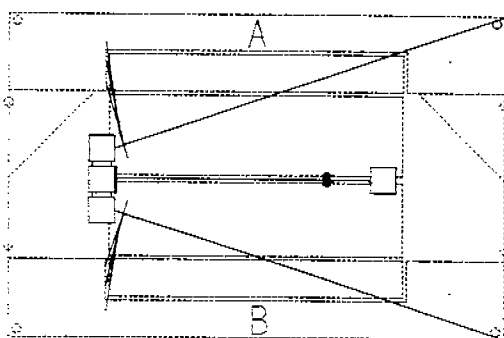

32. Fix the plugs of the slip rings.

33. Hang up the illumination and/or decoration.

34. Fix the bolt, that prevents the drive drum from swinging.

35. Connect the steel cables to the drum.

36. Close both valves on hydro units trailer A and B of the large setting up cylinder.

37. Put the setting up cylinder under pressure.
38. Uncouple the folding up cylinder and the parallelograms on the upside.
39. Lift the masts slightly. Fix eventually the illumination and/or logos.
40. Remove supporting wheel of the swing arm.
41. Place the masts at an angle of 50-55 degrees.

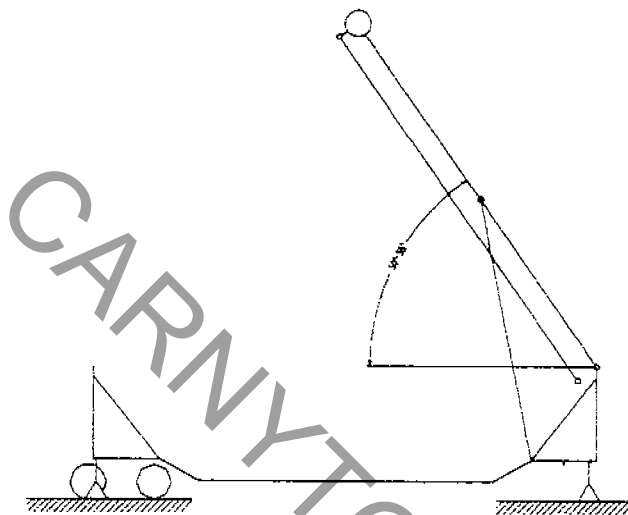

42. Now fix the winch cable by means of the pulley to the swing masts. Unlock the chain. Ease the swing masts now.

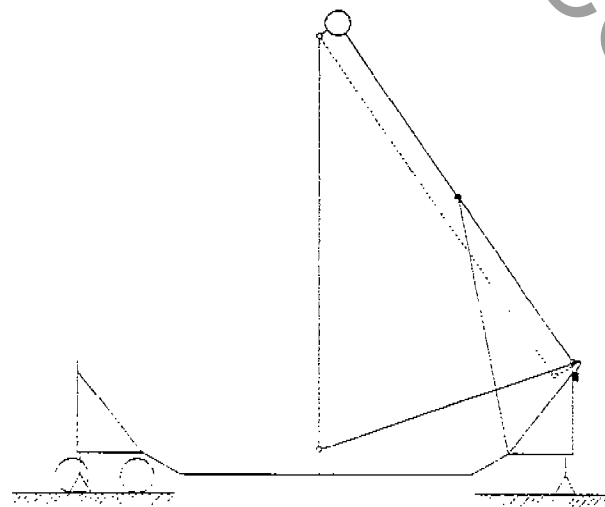

43. Loosen the cables and roll the winches up again.
44. Extend the large setting up cylinders completely.

45. Fasten the cable again onto the swing mast, to lift the swing mast.
46. Put the swing mast into place before the hole by means of the winch. Fix the pin with grease. Don't yet tighten the bolt

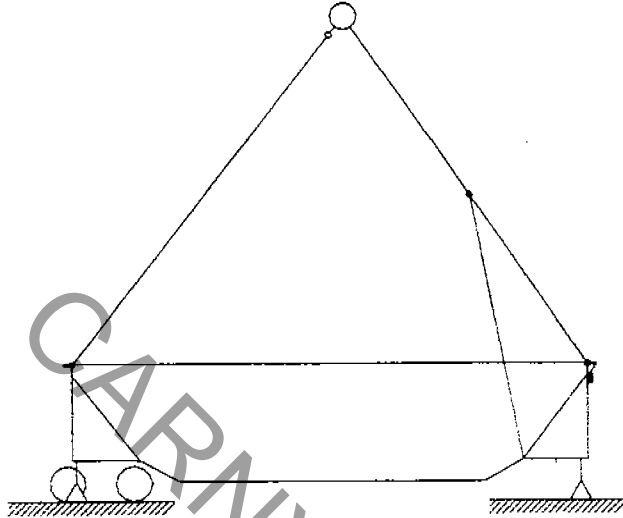

47. Repeat these steps for the other swing mast. When the holes don't come in line, you can rectify this by extending or pulling in the support cylinders a bit.
48. Tighten the bolts for the fixing now.
49. Open the levels of the hydro units (Trailer A and B) to take away the pressure of the large setting up cylinders.
50. Level the attraction.
51. Now fix the two pulleys to the front transverse frame at the corners and lower the swing arm by means of the winches to its middle position.

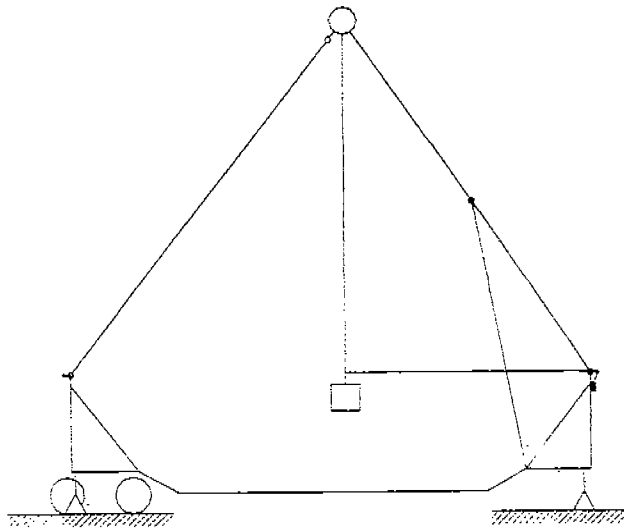

52. Place the platform and the fence. Support the platform if necessary.

53. Remove the bolt blocking the drive drum.
54. Place the winch cable crosslay over the attraction by the pulley onto the top ends. The arms of the gondolas can be lifted now.

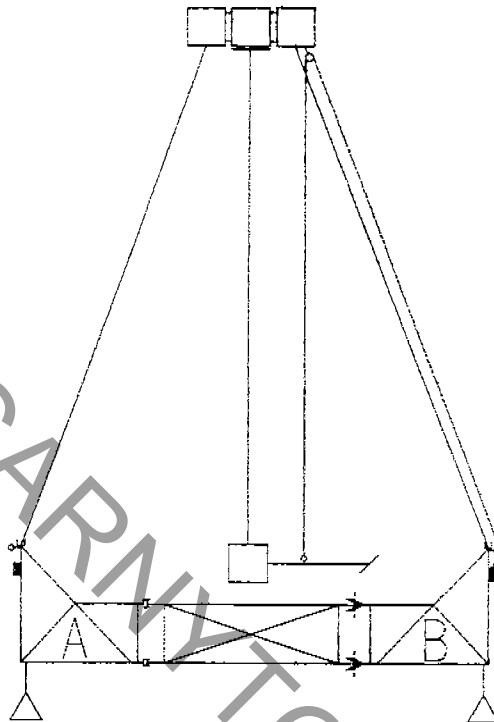

55. Fix the arms of the gondolas with clamping blocs. Take care, the clamping blocks are numbered. Tighten de bolts with 240 Nm.

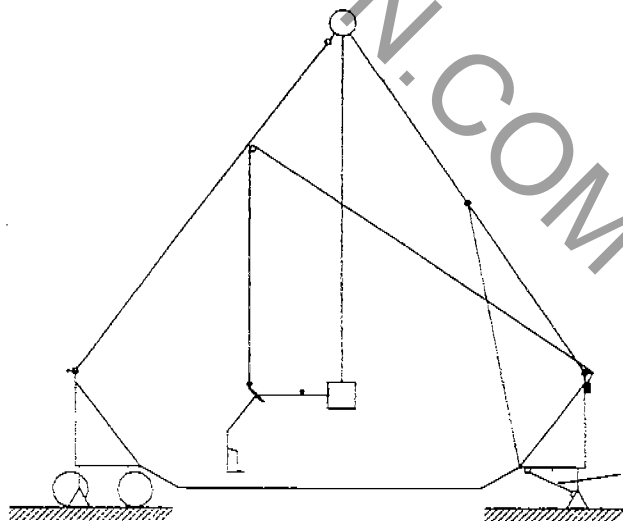

56. Turn the drum 60° to enable the fixing of the arm of the next gondola arm.
57. Repeat this procedure until all gondola arms are fixed.
58. Now fix the winch cable crosslay over the attraction to a support of the swing mast. Hang the gondolas onto the arms. Tighten the 10 bolts of the gondolas with a tightening moment of 240 Nm.

59. Now turn the drive drum to fix the next gondolas.
60. Fix the plugs to the drive drum.
61. Fix the plugs of the gondolas to the arms.
62. Remove the supports underneath the floor.
63. Fix the guys between the pyramids and the trailers. Tightening moment 1700 Nm.
64. Fix the decoration.
65. Put away the material and the tools and take care that they are out of reach for unauthorized persons.

**As long as the trailers are not filled with water it is not allowed to run the attraction.**

CARNY TOWN.COM

## **CHAPTER 8 Dismantlement of the attraction**

The dismantlement of the attraction goes roughly in reverse order of the setting up of the attraction. Take care that you have a safe operating environment to dismantle the attraction.

1. Remove the water from the trailers.
2. Take the gondolas from the arms and place them on the sheers and put the whole at its correct position on the trailer.
3. Take the arms from the drive drum and stack them on top of each other at the indicated position.
4. Fix the bolt to the drive drum, preventing it from turning.
5. Pull the swing arm to the transverse frame by means of the winches and fox the steel cables.
6. Close the levels on the hydro units of the large setting up cylinder.
7. Extend the large setting up cylinders to a pressure of 80 bar.
8. Pull the movable arms a bit under tension by means of the winches.
9. Now remove the pins from the masts by means of the "puller".
10. Lower the arms until they hang vertically.
11. Lower the main cylinders now a little and pull the movable mast a little higher then and fix the transport chains to the masts.
12. The main cylinders now can be pushed in completely now.
13. Fix the cylinders and parallel bars to enable you to fold up the masts.
14. Take care to remove the logo parts and to put the support wheel (on the swing arm) before the masts are taken down.
15. Place the supports underneath the floor at the position where the swing arm rolls over. (for position: see chapter on setting up of the attraction).
16. Remove the bolts of the swing arm and drive the swing arm to the inside.
17. Remove the remnants of the logo parts and the logo holder (when necessary).
18. Remove the plug of the slip ring.
19. Remove the bolts that are used to divide the masts.
20. Move the mast of the front trailer to the inside.
21. Remove the mast of the back trailer to the inside.
22. The gondolas now can be put at the correct position. Secure the sheers with pins.
23. Fold the floors up and secure them.
24. Fold the front parts up.
25. Load up the platform, fence and decoration.
26. Push in the support cylinders at the back side
27. Place the support pyramides at the front side of the trailer.
28. Push in the support pyramides at the front side.
29. Place the truck under the trailer.
30. Dismantle the shores.
31. Remove the lower pins of the transverse frames by means of the "puller".
32. Now take the pressure from the upper pins by means of the pneumatic suspension and remove these pins.
33. Fold up the transverse frames and secure them.

Check very carefully if all parts have been loaded up and have been secured properly.

## **CHAPTER 9    Ordering spare parts.**

If you want to order spare parts, please always mention the following:

- Machine number attraction
- Owner attraction
- Clear description or sketch of the parts you would like to receive.
- Address to which the parts have to be sent.

CARNYTOWN.COM



## CHAPTER 11 Electrical sheme

You will find all the electrical drawings in the other file.

On the following page you will find the layout of the printed circuit board.

This drawing will help you to find a problem when the red-light on the main control-panel is burning.

When the red-light burns you have to look at the printed circuit board in box 1 and see which led is burning. Then look at this drawing to see to which component(s) this led refers to and then you have located the problem.

CARNYTOWN.COM

# CONNECTED CIRCUIT BOARD IN BOX 1

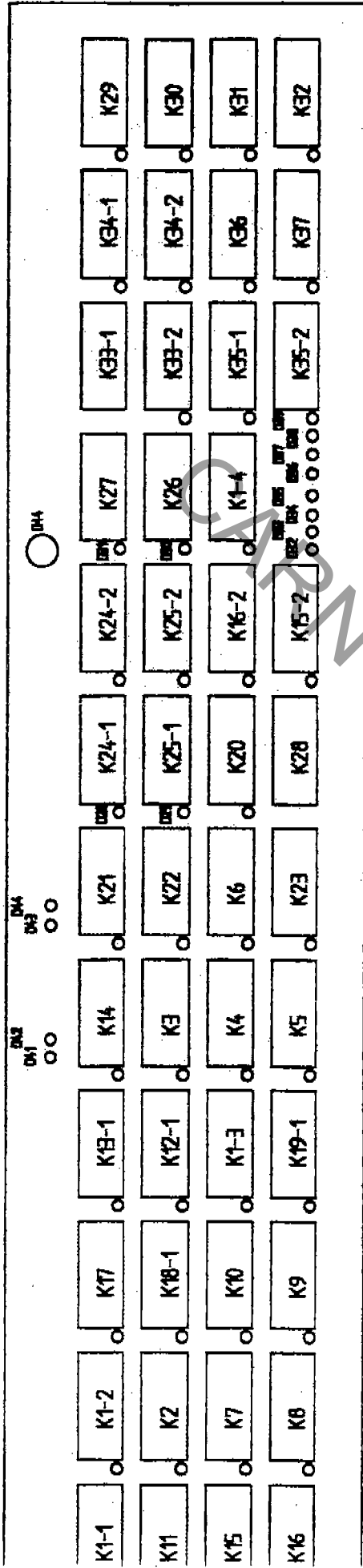

Left El. motor overheated		
Right El. Motor overheated		
Failure Hydraulic Units (left & Right side) and forced cooling	2F2	in Box 1
Cooling failure of cars-motor	1F3	in Box 3
Failure of Left hydraulic Unit	2F3	in Box 1
Failure of Right hydraulic Unit	2F6	in Box 1
Cooling failure of left driving motor	2F10	in Box 1
Cooling failure of Right driving motor	2F13	in Box 1
Main-power disconnection of big Frequency Regulator	1F5	in Box 1
Main-power disconnection of small Frequency Regulator	1F16	in Box 1
Left driving motor overloaded	1F6	in Box 1
Right driving motor overloaded	1F9	in Box 1
Failure left winch	3F1 / 3F2 / 3F6	in Box 1
Failure Right winch	3F13 / 3F14 / 3F18	in Box 1
Failure big Frequency Regulator		Look at the regulator for the kind of failure
Failure small Frequency Regulator		Look at the regulator for the kind of failure
Emergency shutdown = all right		There is a failure when the green led is off.

## CHAPTER 12 Emergency stop

In case of an emergency you can stop the ride with the emergency stop button.

There are two buttons:

- One is fitted on the main controlbox  
When this button is activated, the main swinging arm will go to its normal position (as quickly as possible), the gondola will stop to rotate (as quickly as possible) and the floor stays down.

To reset the system:

Pull the emergency stop button into its normal position.

Reset the system and reset the small frequency inverter. When you have done this, the floor will come up and you can open the safety bars.

- The other button is a separate (red) button.  
When you activate this button, the main swinging arm will go to its normal position (this takes a couple of minutes), the gondola will stop to rotate (this takes a couple of minutes) and the floor stays down.

To reset the system:

Pull this emergency stop button into its normal position.

Reset the main switch in box 1 (Push in the white button and after that pull the black lever downwards and upwards again). Now you have the power back on the system.

Reset the system and reset the small frequency inverter. When you have done this, the floor will come up and you can open the safety bars.

### Power failure

When there is a power failure the ride will stop. (Main swinging arm will stop (this takes a couple of minutes) the gondola will stop (this takes a couple of minutes) and the floor will stay down.

- If you can get the power back on you have to reset the system and the small frequency inverter.  
When you have done this the floor will come up and you can open the safety bars.
- When you can't get the power back on you have to open the safety bars with the separate power supply (from the batteries) cable.  
If this doesn't work you have to remove the back-panel from each car and put a mini-hose onto the cylinder. Now you can open the safety bar by lifting in up.  
You will find a specified drawing of the cylinder in chapter 10.

**CHAPTER 13      Technical specifications Trailers**

**Dimensions**

Length            = 14.65m  
 Width            = 2.5m  
 Height            = 4.0m

**Weight/ division**

Total weight    = 25 ton  
 Shaft pressure   = 15 ton  
 Dish pressure    = 10 ton

**Shafts**

Shafts per trailer = 2

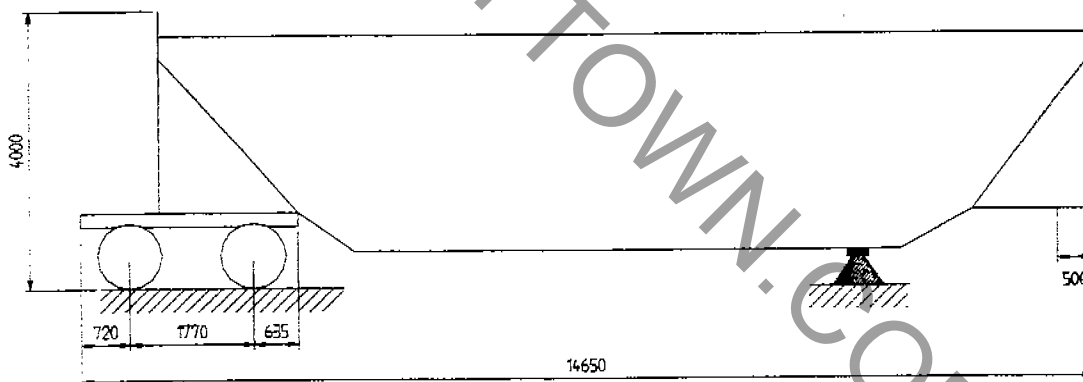

## CHAPTER 14 Technical specifications Attraction

Name of the attraction - Frisbee/Beach Party/Chaos

Manufacturer - KMG

### Dimensions

	Static	dynamic
Length	14.5 m	14.5 m
Width	12.5 m	12.5 m
Height	13 m	22 m

### Speeds:

Max. angle turn swing arm - 120° to the left and to the right

Max. number of revolutions gondola - 8 revolutions/min.

Number of persons - 24

Number of gondolas - 6

### Conditions for functioning

Min. length persons - 1.22 m

Max. length persons - 1.9 m

Min. age - 14

Max. weight - 1800 kg.

Max. duration run - 120 sec.

Weight division recommended - yes

### Electrical data

Voltage - 220 V / 380 V

Connection - 5-core, 3xphase, 1xzero, 1xearth

Frequency - 50 Hz

Drive - 67 kW

Max. current input - 150 A

Max. light capacity - 80 A

Minimum temperature surroundings - - 5° C

Max. wind speed - 5 Beaufort (10m/s)

### Hydraulic data

Per trailer	
Capacity	- 4 kW
Capacity pump	- 15 l/min
Pressure	- 150 Bar
Min. temperature necessary to operate	- - 5°
Max. temperature to operate	- 75°

## **CHAPTER 15 Spare parts list Dolly**

At the following pages you may find the spare parts and eventually a scheme of the dolly parts.

CARNYTOWN.COM

**CHAPTER 16** Addresses

Hydraulic D.O.W. Hydraulic B.V.  
Parkweg 163  
7545 MV ENSCHEDE  
Tel.: 0031 534326972  
Fax: 0031 534326973

CARNYTTOWN.COM