

MFG: JVI INDUSTRIES
NAME: KRAZY KARS
TYPE: NON-KIDDIE

GAS POWERED

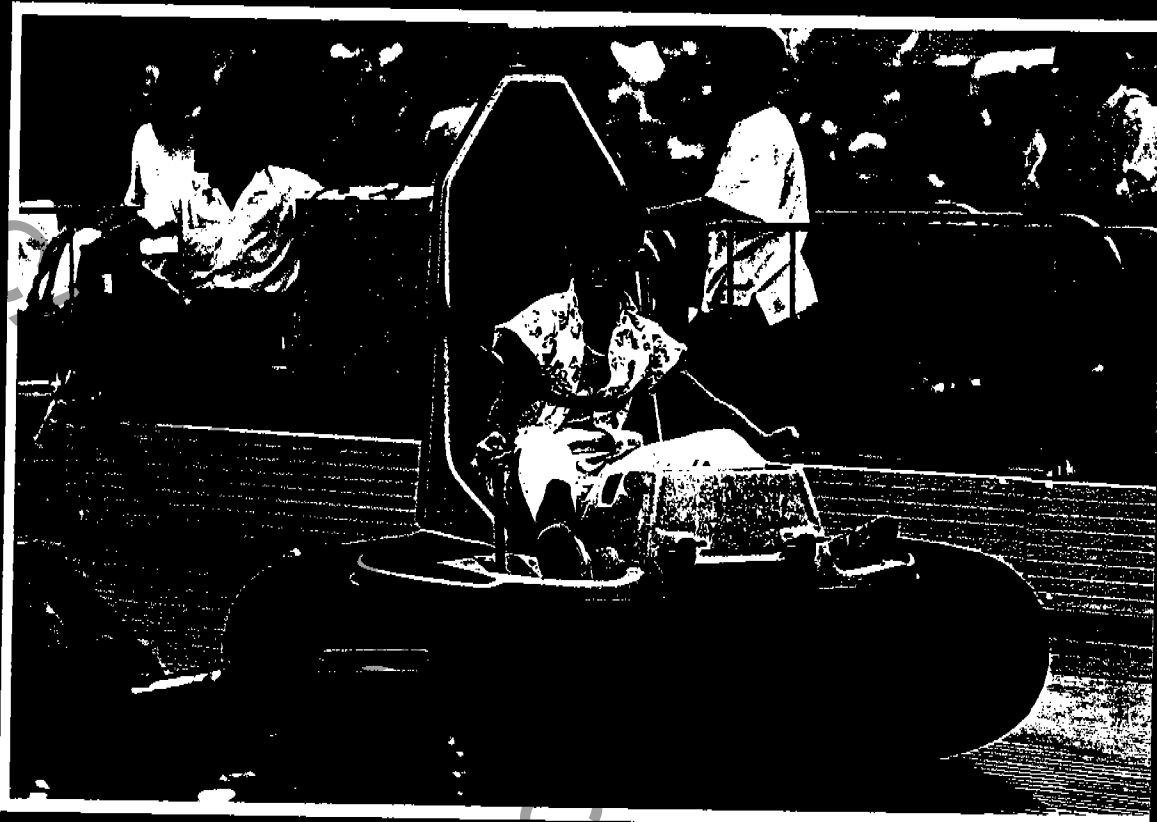

- An excitingly different bumper car
- Appealing to all ages
- Featuring proven Honda power in a tried and tested design
- Simple to operate and simple to maintain
- Single employee control with JVI's optional IDLE-BACK SYSTEM
- May be operated on a variety of surfaces (but works best on JVI's PORT-A-FLOOR SYSTEM)
- Keeps your fun zone crowd coming back for more

JVI INDUSTRIES, INC.

S A L E M , O R E G O N 3 9 9 - 0 8 1 7

GAS POWERED KRAZY KAR

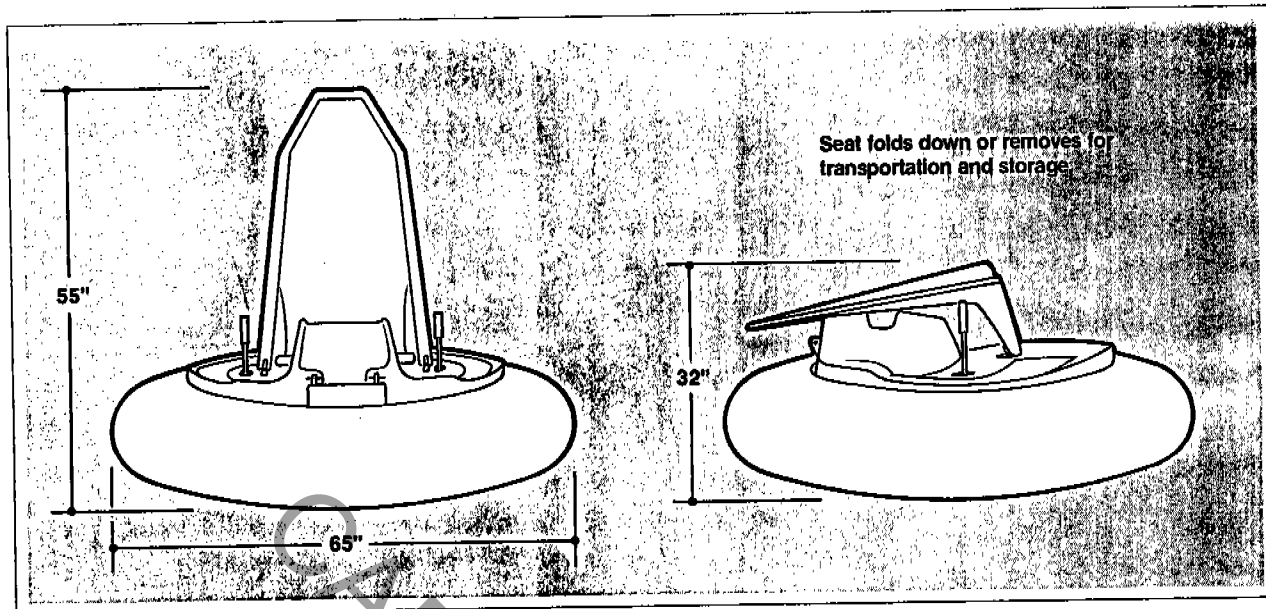

Features: 30 riders per hour per car (based on a two minute ride cycle); reliable 4 cycle Honda gasoline engine with; 1 1/2 gallon fuel tank; welded steel frame; removable fiberglass body, and a contoured folding

and removable padded seat with restraint belt. Standard colors are JVI orange and JVI yellow with black trim. Recommended operating area: 100 square feet per car.

Operation

One passenger per car. The cars forward, reverse and turning motions are controlled by two levers connected to hydrostatic transmissions which power two independent drive wheels. The engine is brought up to operating rpm through a seat activated throttle and speed is controlled through the operating levers.

Construction

Body: Fiberglass with high gloss gelcoat finish

Seat: Fiberglass with restraint and padded inserts.

Frame: Fabricated steel

Engine: Honda GX 140, 5 HP

Drive: Oil bath centrifical clutch with 2:1 reduction

Transmission: Reversible hydrostatic

Wheels: Cast aluminum with pneumatic tires and sealed bearings

Casters: High impact steel casters with pvc coated wheels

Bumper: Coated nylon rip-stop cover encasing an extra heavy air bladder

Finish: Metal surfaces are sandblasted to remove rust and mill scale. Finished with one coat of quality primer and two coats of high grade paint.



JV INDUSTRIES, INC.

P.O. Box 13399
Salem, OR 97309-1399
(503) 399-0817

FAX (503) 581-9537
TWX-910-250-1140
ESL-62019801

■ FABRICATORS OF STEEL AND FIBERGLASS PRODUCTS ■
■ MANUFACTURER OF AMUSEMENT DEVICES ■

SHOWLINE ACCESSORIES IMAGEMAKER FENCE

Half The Battle • Half The Weight

Win the Battle on Maintenance — Clear anodize coating lets you hose down and walk away. You never have to paint.

Win the Battle of Weight — Lower transport cost, less set-up time.

Meet The New Standard In The Business

— Better Image —

Choose your favorite design or ask about custom designing.

• More Versatility • More Optional Accessories •

• More Patterns • More Stability •

• Tri-Claw Design Foot means

less movement on any surface.

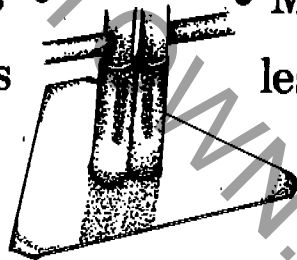

Compare Our Specs To Your Needs

We meet or exceed most requirements with our stock panels.

If we don't, we can customize your order.

Less than 5 $\frac{1}{4}$ inches between bars.

42" standard height.

All welded construction for ultimate strength.

2255

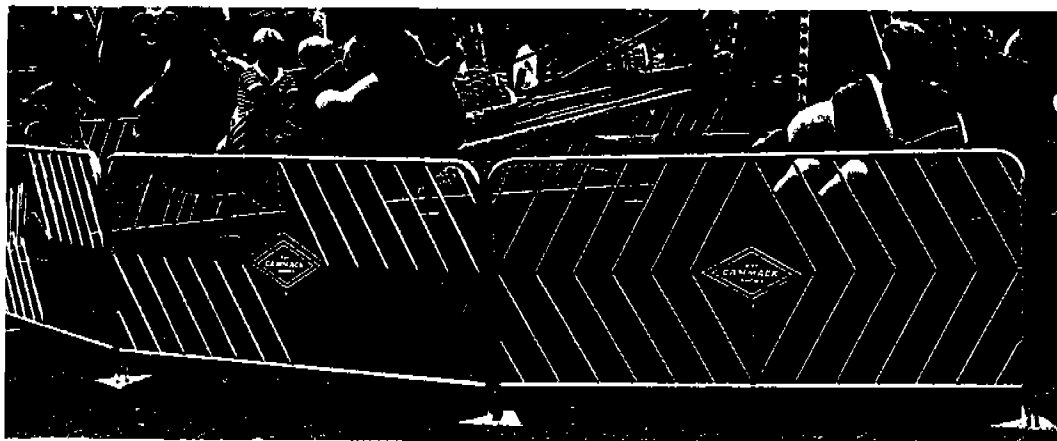

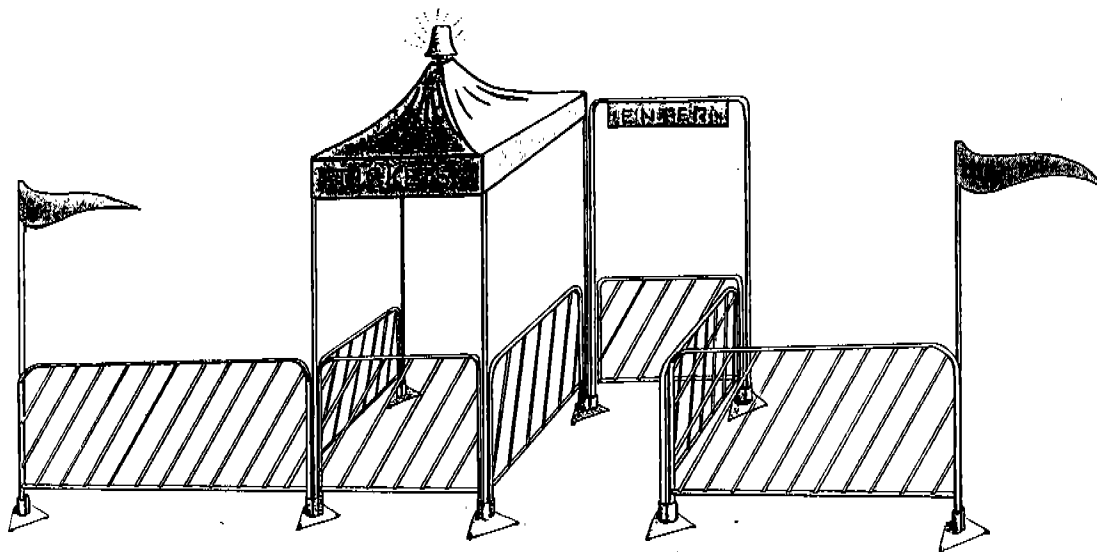

Five Stock Panels

COST EFFECTIVE FEATURES

Custom Design Your Own Space

All Aluminum Construction — 1" Diameter tubing $\frac{1}{2}$ " solid rods are formed and welded into a strong solid panel before being cleaned and anodized with a clear coating that provides protection to the aluminum. Anodizing also creates easy cleaning.

Five Stock Designs — Stock patterns help keep costs down.

Custom Design — Have a new idea, we can build it. We can bring your ideas into reality.

Accessories — Uniformity throughout options allow you to interchange parts for specific situations. Choose and combine any of the following — light poles, flagpoles, ticket booths, canopy covers, ticket boxes, flags, marquee banners.

Gates complete your safety barrier with matching Exit and Entrance gates. Removable Enter and Exit signs give clear direction for better crowd movement.

Racking System — Uniformity allows easy racking storage compartments for tri-claw feet and accessories like exit, enter signs, flags or marquee banner.

Showline Accessories
10899 Converse Rd.
Plain City, OH
43064

For More Information
Feel Free to Call or
Write

161A 979 5959 979 9491



JV INDUSTRIES ANNOUNCES THE ONLY
PROVEN SYSTEM:

IDLE BACK II

Remote Control For
GO KARTS

Instant Control:

- Individual Cars
- Separate Fleets
- Total Track

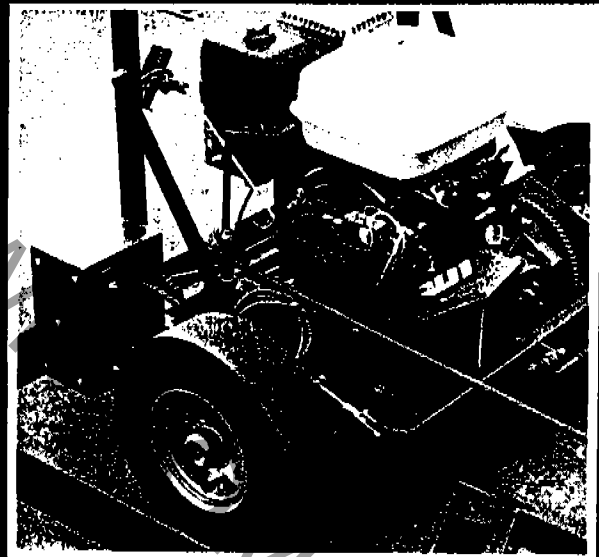

Instant Profit:

- Lower Insurance ■ Fewer Employees
- Reduced Equipment Damage



EYERLY
International Ltd.

PHONE: (503) 399-7708

FAX: (503) 581-9537

CARNYTOWN.COM

**JVI's New
IDLE-BACK II
REMOTE RADIO CONTROL DEVICE FOR GO-KARTS**

At Last

- A proven and reliable field control device for all go-kart operators and operations.

Operating Features:

- Full control of individual cars
- Full control of the entire track
- Full control of multiple fleets
- Console mounted command unit for control of operation from a single location

Cost Control Features:

- Fewer employees necessary for operation
- Much lower customer injury risk
- Greatly reduced employee injury risk
- Substantial reduction in equipment damage

Technical Features:

- Each car mounted unit is fully self contained and requires only minimal service
- Can be installed in the field
- No field adjustments or "tuning"
- Up to one-half mile range
- No federal communications license required
- Backup battery charging system in command console
- Engine driven service free power source
- "Fail-Safe" control to bring engines to idle no matter what
- Does not shut engine off
- Does not interfere with engine ignition system
- Does not effect normal operation of the engine
- Solid state maintenance free electronics
- Patent pending
- 90 day full factory warranty

The complete system consists of:

- For each car:
 1. Engine driven battery charging system
 2. Two channel (four position) receiver with solenoid control circuitry, and battery charging system
 3. Sealed electrolyte battery with battery box
 4. Positive lock solenoid engine control unit
 5. Cables, switches, and installation instructions.
- Console mounted weather resistant controller:
 1. "All Stop" *panic* button
 2. Separate control button for each car
 3. Optional "Fleet" controls
 4. Backup batteries stored and maintained in the console base
 5. Separate hand-held testing transmitter
 6. Remote antenna with 50' of lead.

NARRATIVE DESCRIPTION OF THE IDLE-BACK II SYSTEM

JVI's new Idle-Back II remote radio control system for Go-Karts and other gasoline engine applications represents more than three years of intensive development and testing. The original concept was developed to control JVI's gasoline model Krazy Kars amusement device, which required full operator control of the ride cycle without the engines being killed and restarted. The design project criteria required: a self contained power unit which needed no charging or other service, a reasonable operating range, "bullet-proof" reliability in a host of environmental and operating conditions, and simple installation.

Idle-Back II Operates as Follows

Each car will respond to either of two pair of radio signal transmissions from the control console transmitter. Within each pair, one code brings the engine to the preset idle speed by retracting the governor control and overriding the accelerator setting, the other code permits the accelerator to control the engine speed.

Individual car control is accomplished by using the car-specific individually numbered buttons. Fleet and total track control is accomplished by using the "All Start" and "All Stop" buttons. The codes for entire track and fleet control are common to the group or set of cars addressed; the codes for the individual cars are unique to each car.

Thus, individual cars may be dispatched; fleets may be dispatched; while it is *usually* neither necessary nor advisable, individual cars may be slowed (by momentarily overriding the accelerator in an addressed car); individual cars may be stopped *and* in emergency situations all of the cars on the track and in the loading areas can be immobilized. The "All Stop" signal will bring all engines to idle.

Each car system is fully self contained and the default condition, in the unlikely event of a system failure, is "All Stop."

The console control unit is 110V, line current – as is the backup batteries charging and maintenance system housed in the base of the control console. The control console is designed to be located at the entry to the loading area or wherever is the best view of the loading area and the track, and is weather resistant.

It is not advisable to permit the engines to idle for long periods of time with the radio control in the 'on' mode. The system is designed to maintain fully charged car batteries under normal ride cycle conditions.

Please note that circuitry that decodes the signals, tests each transmission for 75 nanoseconds (three-quarters of one second), and the transmitter design locks out the next signal for that period of time. When the red "transmit" light is momentarily on, a second signal cannot be sent.

Each car button can be lighted. With this feature, when the button is illuminated, the individual car is in the run mode; when the button is not illuminated the individual car is in the idle model. The "All Stop" buttons will override the individual car control – therefore when the individual button light is off the car is at idle, but if the "All Stop" button has been depressed, all cars will be immobilized whether or not the individual button is illuminated. In the event of an emergency total track shut down, the buttons for the cars operating on the track will remain illuminated. To restart these cars, each individual button must be depressed twice: to idle and then back to the operating mode.

Krazy Kars



JV INDUSTRIES, INC.

P.O. BOX 13399 SALEM, OR 97309-1399

(503) 399-0817

■ FABRICATORS OF STEEL AND FIBERGLASS PRODUCTS ■
■ MANUFACTURER OF AMUSEMENT DEVICES ■

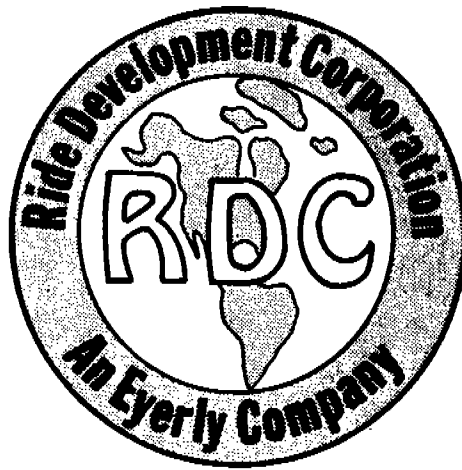

FOREWORD

The Ride Development Corporation Krazy Kars™ Amusement Ride is constructed of quality materials. Craftsmanship is the key to Ride Development Corporation Products with quality and durability as primary considerations. The design is appealing to the eye, and approved by professional engineers.

A Krazy Kars that continues to operate well needs a regular and careful maintenance program, the replacement of worn or damaged parts, and regular lubrication and service attention.

Ride Operators must be properly instructed both as to operating techniques and maintenance service requirements. As with any other mechanical device, an operator must never operate the Krazy Kars if he suspects a malfunction!

No modification of any part of the Krazy Kars or substitution of parts is authorized by Ride Development Corporation. Any unauthorized repair or modification may drastically change the stress loading, may reduce safety, and may result in failure.

Information in this manual is intended to serve as a guide to operation, trouble shooting, maintenance, regular lubrication and service, and replacement part selection.

RIDE DEVELOPMENT CORPORATION

AN EYERLY COMPANY

2050 TURNER ROAD, SE
P. O. BOX 12155
SALEM, OREGON 97309

MANUFACTURERS' LIMITED NORTH AMERICAN WARRANTY FOR NEW AMUSEMENT RIDES

Ride Development Corporation warrants that purchased property is free from all defects in material and workmanship at the date of delivery and 90 days thereafter. Ride Development Corp. does not warrant that purchased property will meet or exceed federal, state and local design criteria or electrical codes. Ride Development Corp.'s liability is hereby limited to the repair or replacement of any part which is defective due to failure of material or defective workmanship. The cost of returning defective parts to Ride Development Corp. and the cost of transportation of repaired or replaced parts to Purchaser shall be born by Purchaser. Ride Development Corp. shall not be liable for down time or loss of operating revenue or any other commercial consequential damages. Losses resulting from improper maintenance or failure to observe Ride Development Corp.'s operating instructions are expressly excluded from this warranty.

It is expressly understood between Ride Development Corp. and Purchaser that all warranty is void and Ride Development Corp. disclaims any and all liability or responsibility for failure, loss or damage if parts are installed or any repairs made to the purchased property which are not factory approved in writing or if ride is assembled, maintained, or operated other than as recommended in the Parts Catalogue and Operating Manual provided with each ride.

THIS WARRANTY, AND THE OBLIGATIONS AND LIABILITIES OF RIDE DEVELOPMENT CORP. HEREUNDER ARE IN LIEU OF ALL OTHER WARRANTIES, GUARANTEES, CONDITIONS OR LIABILITIES, EXPRESS OR IMPLIED, INCLUDING WARRANTIES OF MERCHANTABILITY AND FITNESS FOR A PARTICULAR PURPOSE AND SHALL NOT BE EXTENDED, ALTERED OR VARIED EXCEPT BY WRITTEN INSTRUMENT SIGNED BY RIDE DEVELOPMENT CORP. AND PURCHASER.

Specifications listed are for United States models delivered within the United States, Canada or Mexico. Ride Development Corporation hereinafter called company, is represented by distributors and agents in the United Kingdom, Ireland, the Common Market Countries, Central and South America, Japan, Indonesia and other foreign countries who provide sales assistance, warranty and repair services. Export models and specifications may be different from domestic versions. The company's North American warranty is null and void on any unit purchased for United States delivery and then exported within the warranty period. Export model warranties are administered by company's agents and distributors within the named countries and by the company for export sales to countries other than those named.

CONTENTS

1	LOCATION OF SERIAL NUMBERS
1	TRANSMISSION IDENTIFICATION
2	OPERATING INSTRUCTIONS
3	ADJUSTING THE STEERING LEVELS AND HYDROSTATIC TRANSMISSIONS
5	PREVENTIVE MAINTENANCE
6	FLOOR MAINTENANCE
6	PLASTIC INSULATION REPLACEMENT
7	LUBRICATION INSTRUCTIONS
9	TROUBLE SHOOTING THE CARS
11	ELECTRICAL TROUBLE SHOOTING
12	CAR ELECTRICAL WIRING DIAGRAM
13	INSTALLING BUMPER TUBE AND COVER
14	CAR STORAGE DURING NON-OPERATING SEASON
15	COMPONENT IDENTIFICATION
21	TRANSMISSION CARRIER ASSEMBLY
22	RECTIFIER ASSEMBLY

LOCATION OF SERIAL NUMBERS

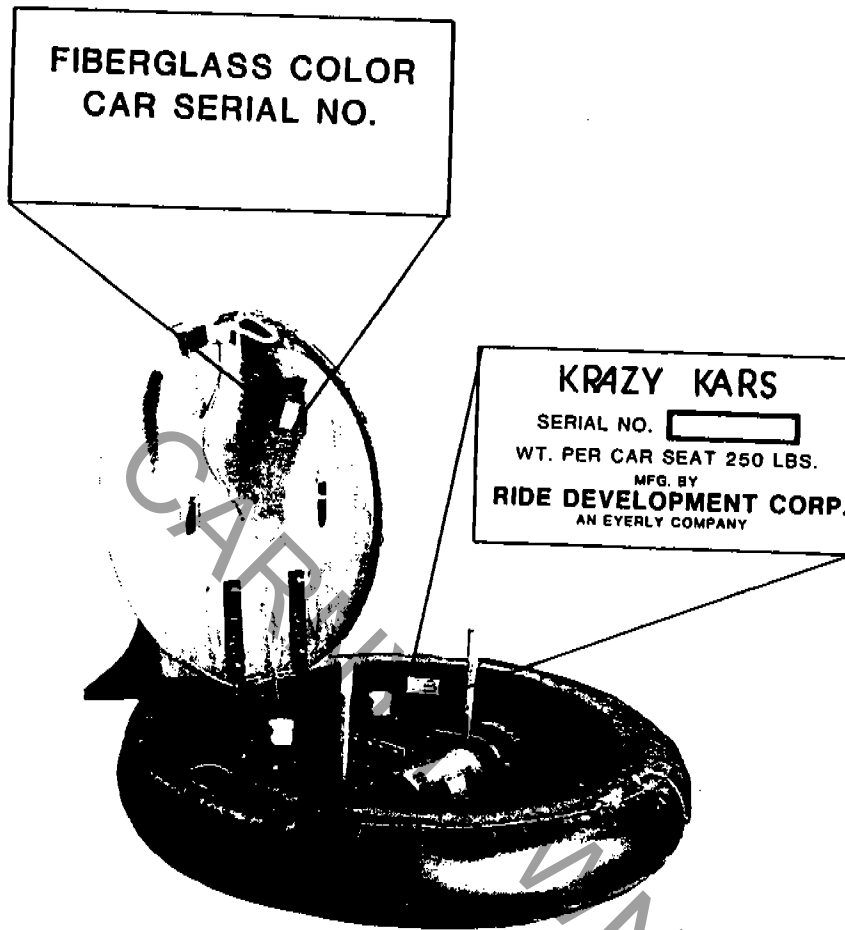

TRANSMISSION IDENTIFICATION

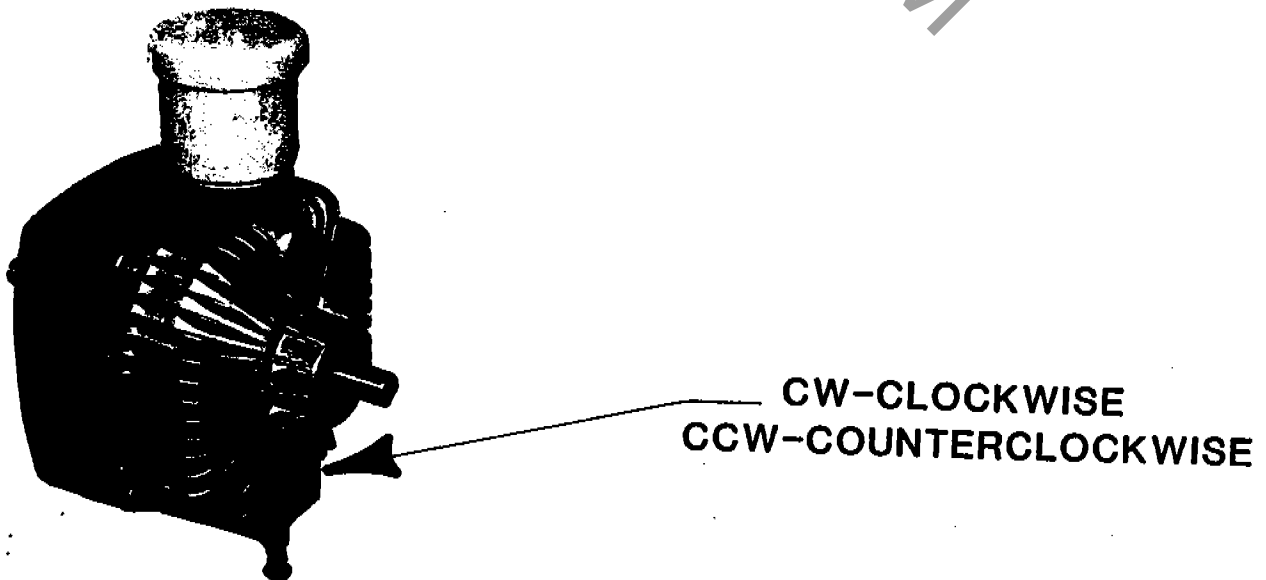

OPERATING INSTRUCTIONS

2

PRIOR TO OPERATING RIDE:

1. Inspect floor for tools and other foreign objects.
2. If present, squeegee standing water from floor.
3. De-activate all seat by pass switches.
4. Plug in "start" (on) "stop" (off) push button stations. Some rides have fixed push button stations. Mobile rides have a receptacle at each end of the ride.
5. Adjust timer (0 to 5 minutes) to determine ride length.

SPECIAL CAUTIONS:

6. Limit patrons by age, weight, seating, etc.
 - (a) Pre-school children should not be allowed on this ride.
 - (b) Patrons weighing in excess of 250 pounds exceed the car capacity.
 - (c) Allow only one (1) person per car.
 - (d) Severely handicapped persons should not be allowed on this ride.
 - (e) Loose clothing & long hair must be secured so that they cannot fall into the control handle openings.
7. Seat restraints must be in place about the passengers trunk and both arms must be free.
8. No car may be loaded or unloaded while the floor is energized.
9. During the ride cycle, keep spectators well away from bumpers, entrance and exit.

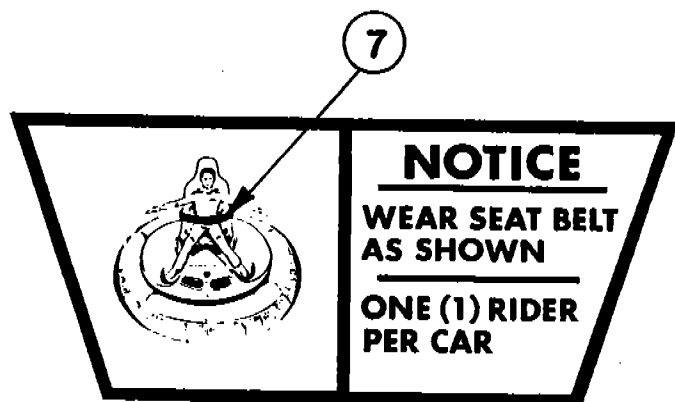

RIDE INSTRUCTIONS:

10. Car direction of travel and speed is determined by location of control levers.
 - (a) For a forward motion, push both levers forward.
 - (b) For a reverse motion, pull both levers backwards.
 - (c) Steering is accomplished by varying the control arm location with respect to each other and their neutral position.
 - (d) A spinning motion is accomplished by pushing one control arm forward and pulling one backwards at the same time.

OPERATION PROCEDURES:

11. Turn on main disconnect switch.
12. Push "Start" (on) push button.
13. If a car(s) fails to activate because a passenger does not weigh enough to operate the seat switch, the car may be energized by resetting the by-pass push button to the on position. **TURN OFF AFTER USE.**
14. Emergency stops can be accomplished by pressing the "Stop" (Off) push button.
15. The ride will automatically stop at the expiration of the timer setting.

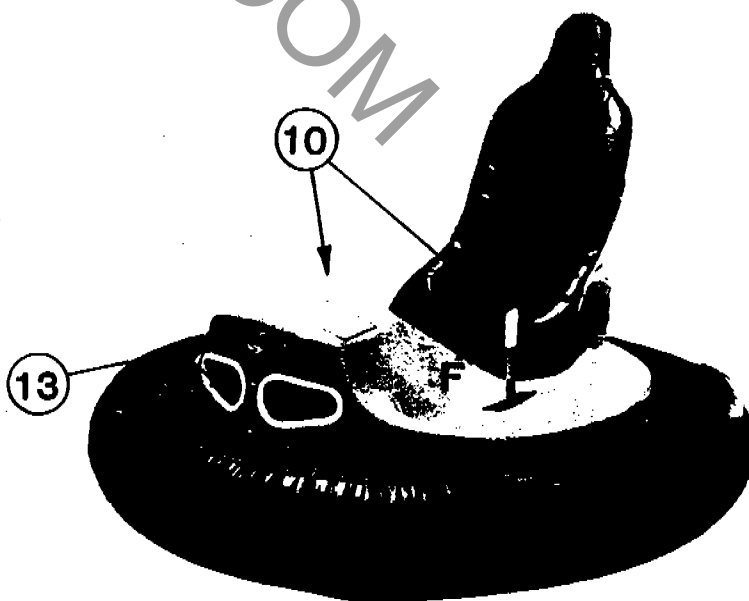

ADJUSTING THE STEERING LEVERS AND HYDROSTATIC TRANSMISSIONS

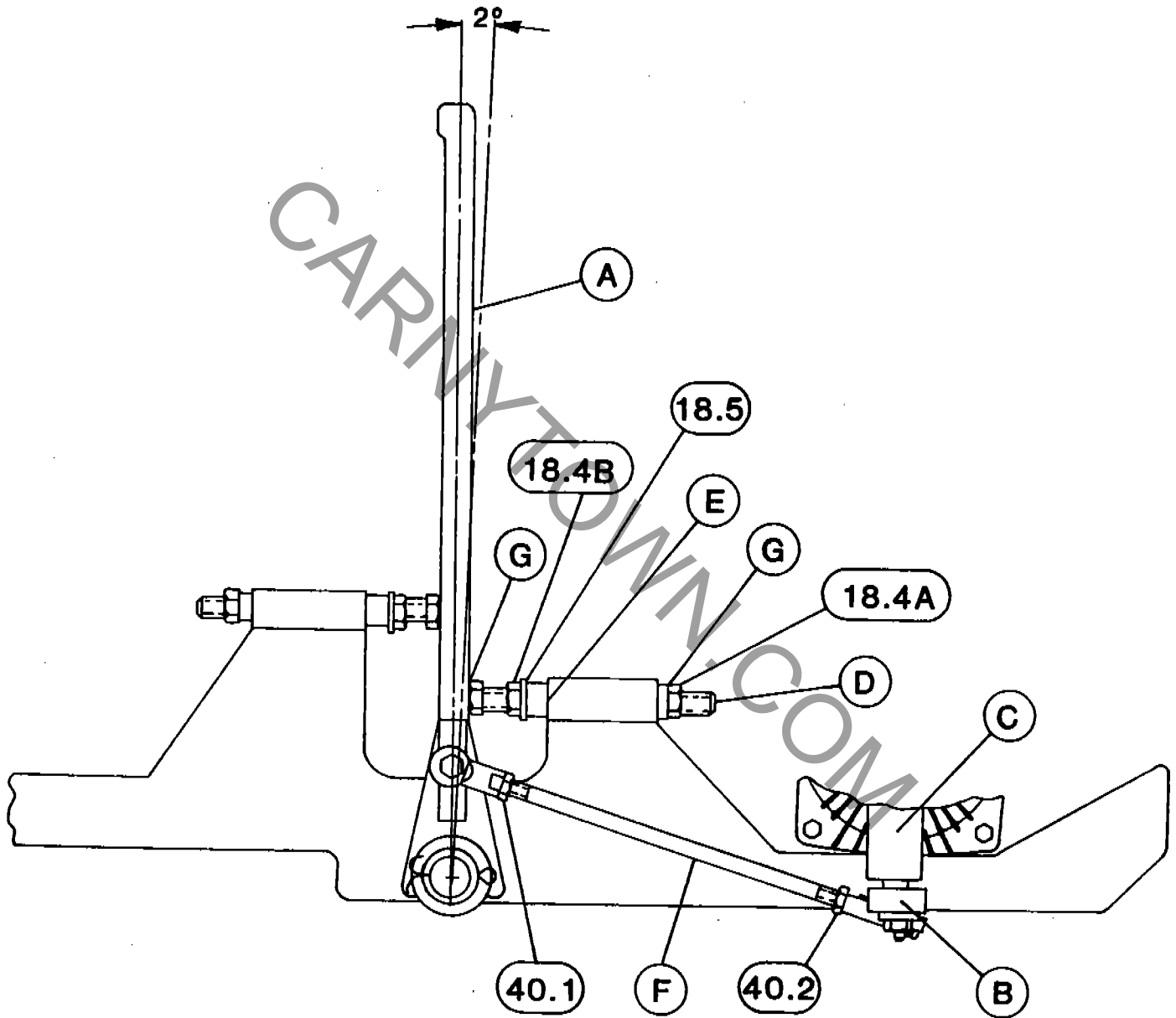

CARNYK TOWN.COM

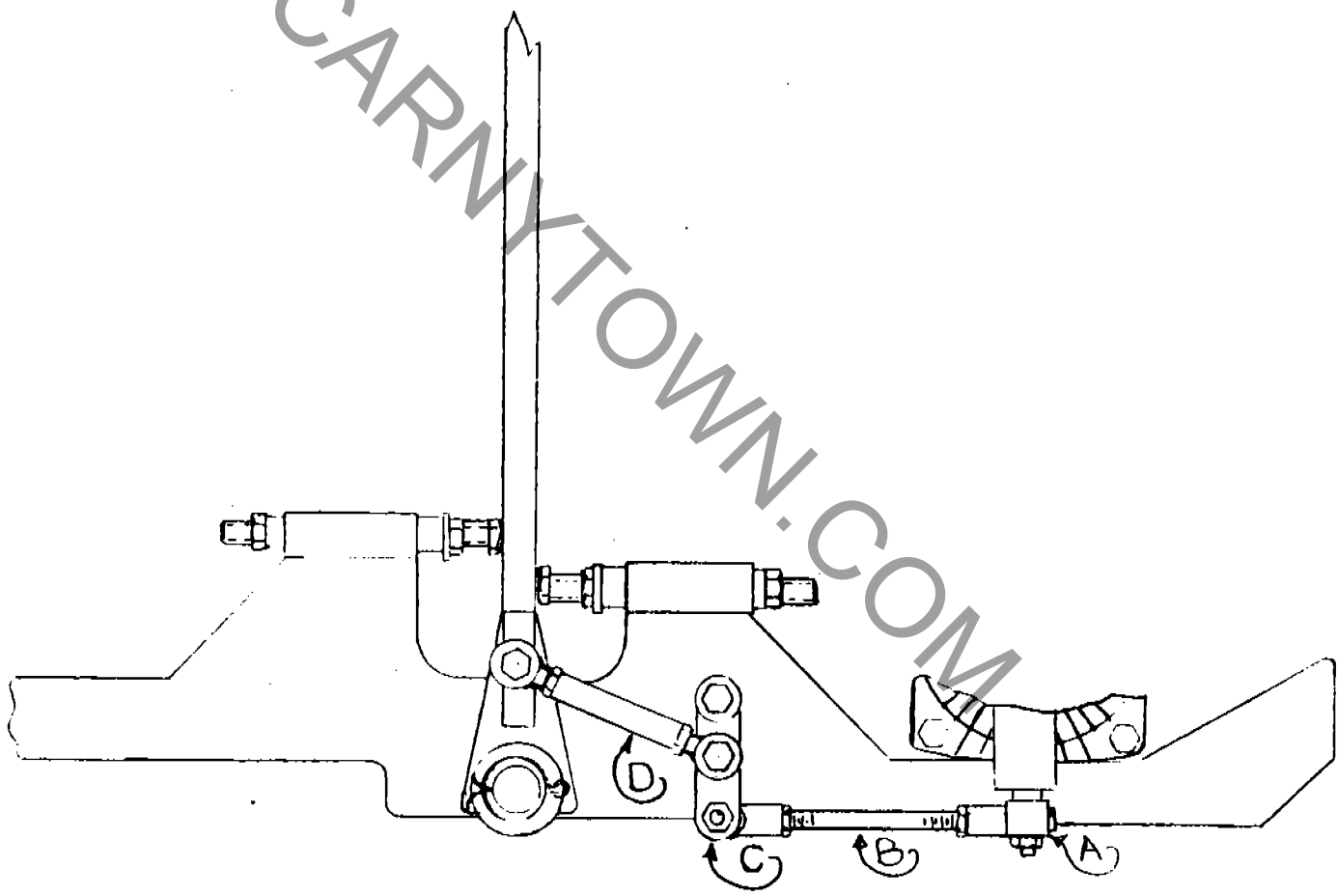

ADJUST ROD (B) SO TRANSMISSION LEVER (A) IS 90° TO STEERING LEVER FRAME AND BELLCRANK LEVER (C) IS STRAIGHT DOWN.
ADJUST TUBE (D) AS YOU WOULD CONTROL ROD (F) ON PAGE 3 AND 4 OF YOUR KRAZY KAR OPERATING AND SERVICE MANUAL.

STEERING LEVER LINKAGE MODIFICATION ADJUSTMENT				
DRAWN BY:	SCALE:	NO. REQ'D.:	MATERIAL:	
DATE:	NEXT ASSY.:	SDS. NO.:	SDD. BY NO.:	

Drg. No.

ADJUSTING THE STEERING LEVERS AND HYDROSTATIC TRANSMISSIONS

1. Centering Steering Levers

Position steering lever (A) in a vertical position and inclining about 2° away from hydrostatic transmission (C) by adjusting nuts (18.4-A) until all contact points (G) are at zero. Lever at this time should have zero movement.

2. Adjusting Neutral on Hydrostatic Transmission

To position bell crank (B) on transmission (C) at neutral mode, first place wood block under frame behind each drive wheel so each is free of floor. Loosen right hand threaded nut (40.2) and left hand threaded nut (40.1). After making sure all metal objects are clear of floor, energize floor. Turn on seat by-pass toggle switch.

CAUTION: CARE MUST BE MAINTAINED AT THIS TIME AS DRIVE MOTOR HAS BEEN ACTIVATED AND MOVING DRIVE BELTS ARE EXPOSED. BEWARE OF LOOSE CLOTHING, LONG HAIR, ETC.

Rotate control rod (F) right or left to center bell crank (B) in neutral position. Turn off by-pass switch, being careful not to move rod (F), tighten nuts (40.1) and (40.2). Activate car motor and push steering lever to forward and reverse positions, release to allow a return to neutral by means of the spring-loaded plunger assembly. If adjusted properly, drive wheel will stop, if not, repeat above.

3. Car Speed Adjustment

Back off nuts (18.4-B) towards hex head of plunger bolt (D) until washer (18.5) does not make contact with point (E) on plunger housing. The steering lever (A) travel should not be stopped by the hydrostatic transmission bell crank (B). Damage will occur to transmission if allowed to operate in this manner. Adjust nuts (18.4-B) away from plunger bolt (D) hex head until washers (18.5) make a solid contact with point (E) of plunger housing.

PREVENTIVE MAINTENANCE

1. Daily: Check car for loose or, broken wires & inspect tires for wear. Adjust & replace if excessive wear is indicated to help prolong life of stainless steel floor.
2. Daily: Purge machinery compartment with compressed air. Direct air into openings of the motor to help prevent a build-up on the armature at the brushes.
3. Daily: Sweep or vacuum ride floor to promote best slipper contact and reduce introduction of foreign materials into the motor.
4. Daily: Apply silicone to the bumper tube cover to reduce friction and prolong its life.
5. Daily: Apply Armour All or equivalent, to the vinyl seat cover to prolong life and resist parting of the material.
6. Daily: Inspect slipper contacts for sharp edges due to being worn flat. Restore radius by grinding or, replace.
7. Weekly: Inspect slipper contact braided leads for arc burns, wear, etc. Replace if current carrying capacity has been reduced.
8. Weekly: Inspect each fastener in the car. Hand wrench tighten all loose nuts, set screws, etc. Be especially careful to maintain an equalized tensioning of fasteners in the bolt circle of taper locks during tightening.
9. Each four (4) weeks, or 100 hours of operation, which ever occurs first, visually inspect motor brushes and replace if indicated by excessive wear.
10. Squeegee standing water from floor to reduce possibility of water damage in the car machinery compartment.

FLOOR MAINTENANCE

PORTABLE AND PARK MODELS

6

The track or floor is the most important component of the entire system.

As with any mechanical device, proper maintenance will result in longer trouble-free operation.

The floor of the portable model must be leveled at each set-up and checked daily. Adjustments in outrigger jacks and/or main frame will have to be made if settling occurs. The transition from main floor center section (trailer section) to the inner wings at the hinge point *must* be flush, flat and level. If the wing sections or the main frame section settles or is set-up out of alignment, excessive wear on the car contact slippers and floor will result.

The floor of the park model must be installed with all deck sections flush, flat and level and each panel joint should be checked periodically. If settling does occur it will be necessary to re-align deck sections until the adjoining sections are flush. Use metal shims between the deck and the steel frame. If shimming is necessary, the shims must be located at the deck securing screws to assure their not being vibrated out.

A clean floor will greatly increase the life of the car components and the floor. To enhance a long life and trouble-free operation, daily maintenance of the floor is a must. Keep it clean! The best method is a daily vacuuming. If residue from mud or grime is allowed to build up it will be necessary to wash down with water followed by a squeegee to remove water and grime. If water is not available, use a fine bristled broom in addition to an industrial-type vacuum cleaner.

NOTE: DO NOT USE A HIGH PRESSURE WASHER OR STEAM CLEANER!

Make a thorough check of stainless steel floor and insulation periodically to inspect for lifting from the plywood underlay. If ride is operated with floor sections out of alignment, serious damage will result to the stainless steel strips and the insulation between the stainless steel strips. If there is any lifting of the stainless strips, they must be re-secured with 10 x $\frac{5}{8}$ " flat head stainless steel screws countersunk to flush with stainless steel strips. If the insulation has lifted it will be necessary to re-secure with $\frac{1}{2}$ " or $\frac{5}{8}$ " wire brads. Make certain insulation is brought down flush with steel.

PLASTIC INSULATION REPLACEMENT

A. Instructions for Replacing Plastic Insulation on KRAZY KARS deck.

1. Carefully separate the plastic strips from the plywood, using a putty knife, wood chisel or, similar tool. Wood removal is prohibitive.
Grasp plastic with pliers or vise-grips and peel back sharply. **Do not** pull straight up, or at 90° angle, as this will tend to pull the top ply lamination loose or splinter the lamination itself.
2. After plastic strip removal, wire brush away old glue to a bare wood surface, and clean with M.E.K. to remove all contaminates.
3. Clean the new plastic strips (scored side) with M.E.K. solvent. Make sure this side is kept clean before applying cement.
4. After plywood and plastic strips are prepared, apply a light coat of 3M Brand "Fastbond" 5 contact cement, or equivalent, on both the plywood and plastic strips. Make sure the cement is applied to the scored and cleaned side of plastic. After cement has set so that it is dry to the touch, apply one more light coat to each and let set again until dry to the touch.
5. Apply plastic to wood, cemented sides together and in exact position to be bonded. Shifting of plastic on the wood after cement contact is not allowed. Use a roller to assure a firm even bond.

LUBRICATION INSTRUCTIONS

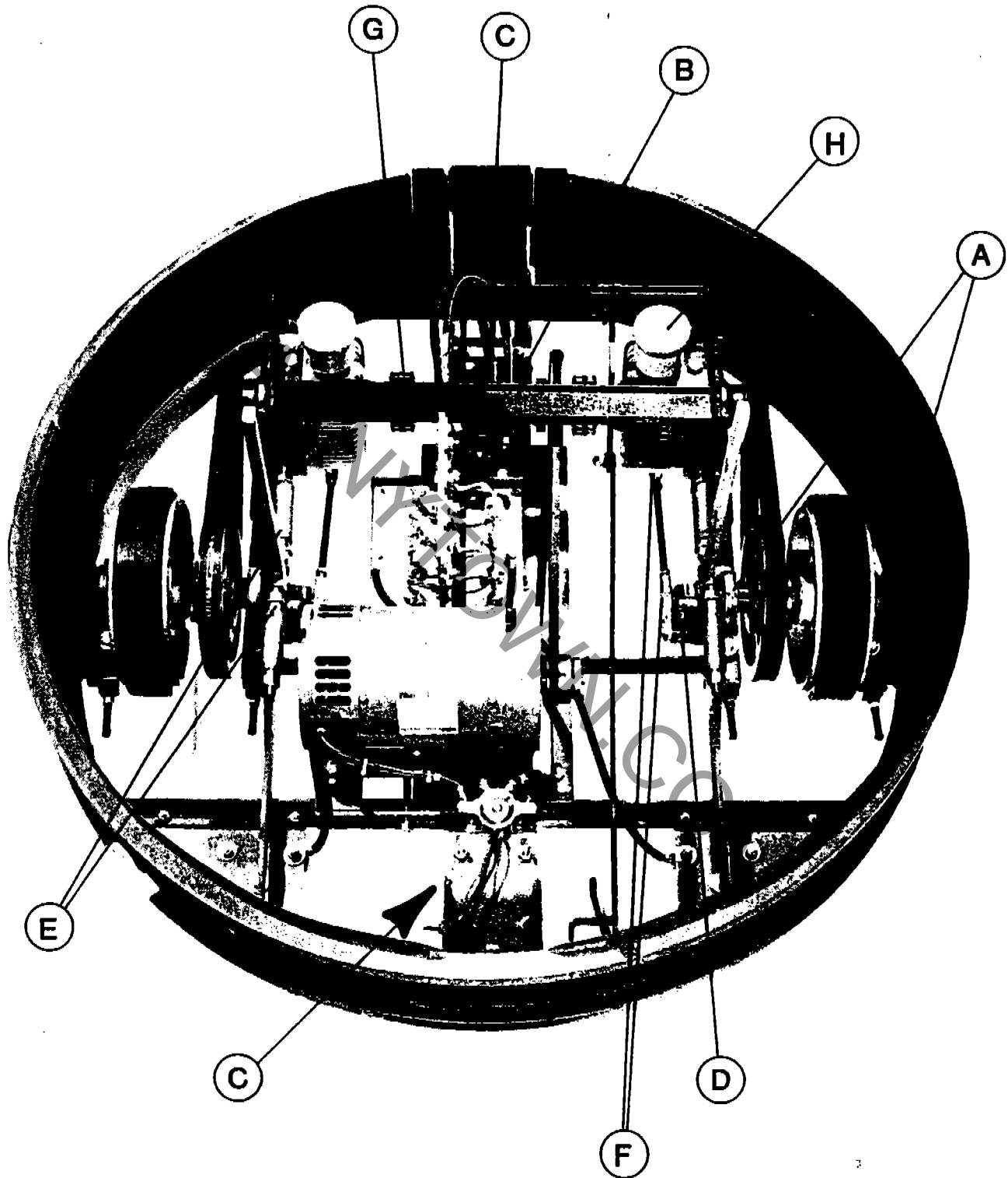

TROUBLE SHOOTING THE CAR

CAUSES AND CORRECTIONS

Excessive Tube Punctures:

1. Under pressurization. — Inflate to 5 to 6 PSI
2. Improperly installed tube. — Readjust as required for proper seating.
3. Foreign projection punctures. — Check ride bumpers and perimeter bumpers for protrusions and correct.

Car Pulls To One Side:

1. Unequal actuation of hydrostatic transmission. — Adjust control rod for equal throw.
2. Low oil level in hydrostatic transmission. — Fill transmission hydrostatic to proper level and check for leaks.
3. Steering lever out of adjustment. — Match adjust steering levels to an upright position set to incline about 2° from operator.
4. Broken chain. — Repair or replace with new chain and lubricate.
5. Loose or broken drive sheave. — Tighten or replace with new drive sheave.
6. Loose or broken drive belt. — Tighten or replace with new drive belt.

Motor Runs, Steering Levers Engaged, Car Does Not Drive:

1. Hydrostatic transmission in neutral mode. — Adjust steering levers to upright position inclining 2° from car operator.
2. Broken motor drive belt. — Replace belt.
3. Oil low in hydrostatic transmission. — Fill to proper level and check for leaks.
4. Steering levers out of adjustment. — Adjust steering levers to upright position inclining 2° from car operator.

TROUBLE SHOOTING THE CARS

CAUSES AND CORRECTIONS

10

Excessive Sparking:

1. Dirty floor contacts. — Clean contact surface to bright metal.
2. Dirty floor. — Thoroughly clean floor.
3. Low voltage. — Provide correct primary supply to transformers.
4. Inverted arch in contact rubber straps. — Remove straps and turn 180° to reverse arch to restore contact pressure.
5. Worn floor contacts. — Replace with new contacts.
6. Uneven floor conductors. — Check floor fasteners for tightness. — Shim and level if necessary to provide smooth, panel-to-panel transition.

Drive Motor Fails to Operate:

1. Faulty seat switch. — Replace with new switch.
2. Insufficient passenger weight to operate seat switch. — Utilize by-pass switch to by-pass circuit.
3. Loose connection in switch circuit. — Tighten connections.
4. Faulty solenoid. — Replace with new solenoid.
5. Worn motor brushes. — Replace with new brushes.
6. Blown Fuse(s). — Replace with new fuse(s).
7. Defective Diode(s). — Replace with new diode(s).
8. Defective or faulty motor. — Replace with new motor.
9. Floor panel shorted or not energized. — Check for shorted panel(s) or energize floor.
10. Missing or defective floor contact. — Replace with new contact.

ELECTRICAL TROUBLE SHOOTING

This section assumes power to the floor is on, of proper voltage, and proper current capacity.

Car Runs Erratically:

A, B, C, I, J

Car Will Not Run In Any Position:

A, B, C, D, E, F, G, K

Fuse Blowing, Immediate & Consistent:

C



Car Runs Backwards:

H

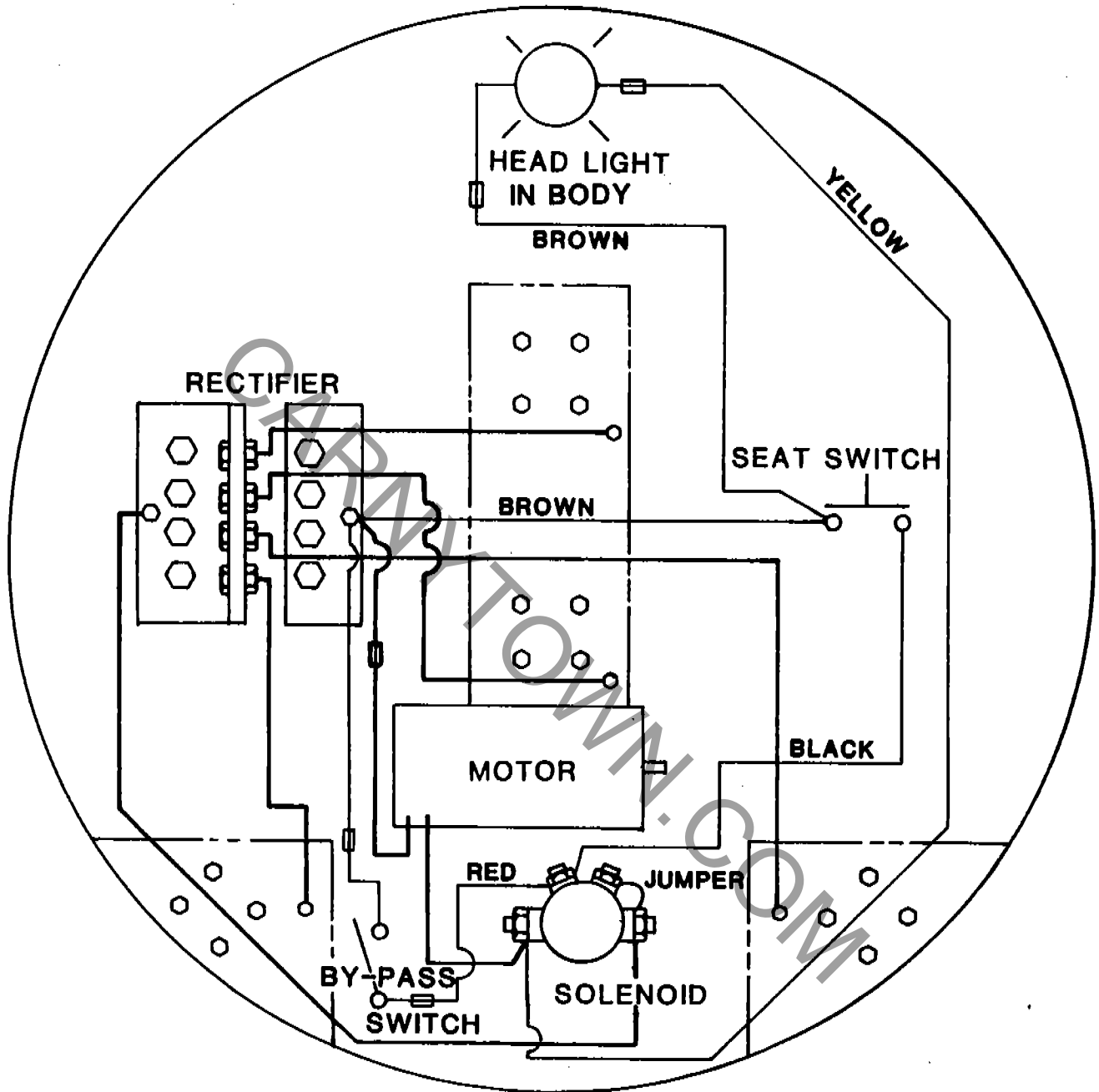
- A. Check fuse
- B. Check power to top of fuse
- C. Check Diodes
- D. Check power out of rectifier
- E. Turn on seat by-pass switch
- F. Check by-pass solenoid
- G. Check power at motor leads
- H. Reverse motor leads
- I. Check slipper contacts, clean slippers to bare metal.
- J. Check car deck, clean thoroughly
- K. Check motor



KEY

-  #6 WELDING CABLE
-  14 GAUGE STRANDED WIRE
-  CRIMP ON WIRE CONNECTOR

INSTALLING BUMPER TUBE AND COVER

1. Insert lower 1/8" cable through 1/2" round hole and pull loose ends together until snugly fit against the car frame wall and lying within the rim channel.
2. Pull lower cable taut for absolute bearing around the car frame and install 1/8" cable clamp without relaxing pressure on the cable.
3. Install tube with valve stem protruding at right angel to the car frame wall. Adjust tube to an equalized position about the frame and located in such manner as to prevent pinching of the tube at final closure of the cover. Secure valve stem with nut.
4. Insert upper cable as in Step 1.
5. Carefully tuck cables into rim channels.
6. Install upper cable as in Step 2.
7. Inflate tube to 10 PSI. Inspect cover for symmetry.
8. Reduce air pressure to 5 to 6 PSI.

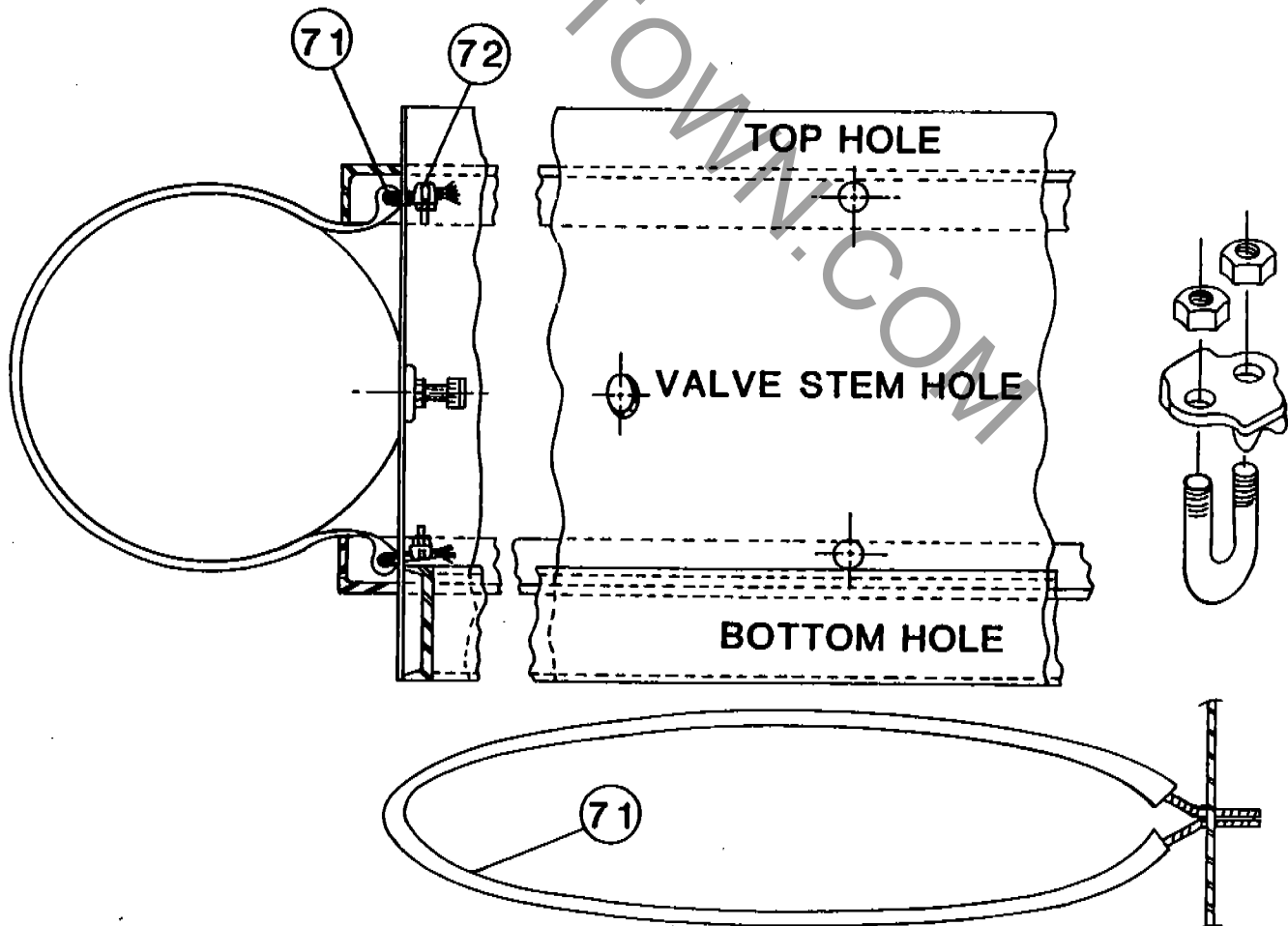

CAR STORAGE DURING NON-OPERATING SEASON

14

1. INSPECT CAR FOR WEAR, DAMAGE AND DEFECTS. TIGHTEN ALL BOLTS AND ORDER REPLACEMENT PARTS.
2. THOROUGHLY CLEAN CARS.
3. LUBRICATE ALL LUBRICATION POINTS.
4. APPLY A GENEROUS COAT OF SILICONE TO THE INFLATABLE BUMPER COVER.
5. REDUCE BUMPER TUBE PRESSURE TO 1½ PSI.
6. STORE IN A DRY AREA WHERE THE AMBIENT TEMPERATURE DOES NOT REACH FREEZING.
7. INSPECT FOR PRESENCE OF MOISTURE EVERY THIRTY (30) DAYS.

CARNYTOWN.COM

COMPONENT IDENTIFICATION

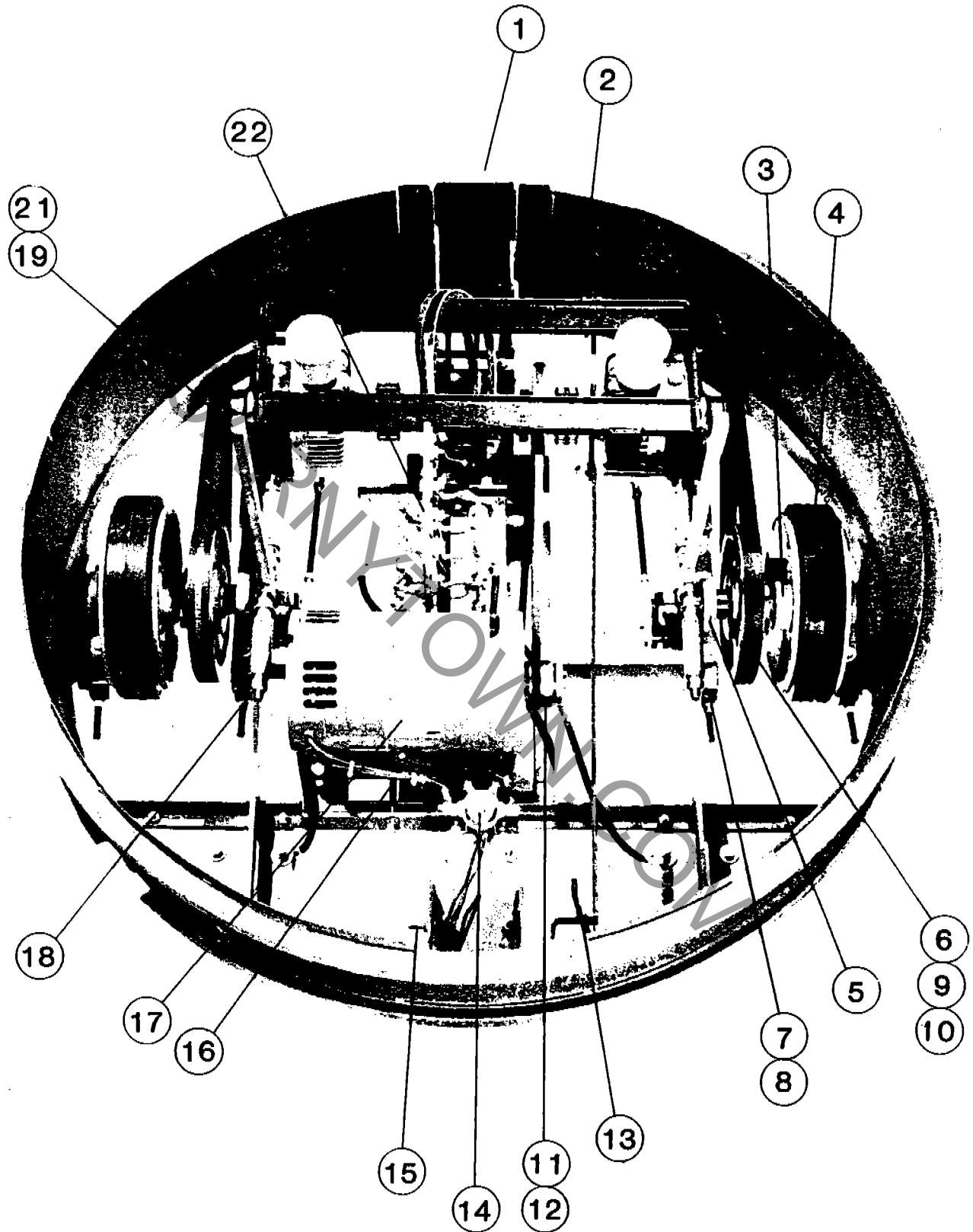

CARNYTOWN.COM

COMPONENT IDENTIFICATION

THIS CASTER ONLY (31)

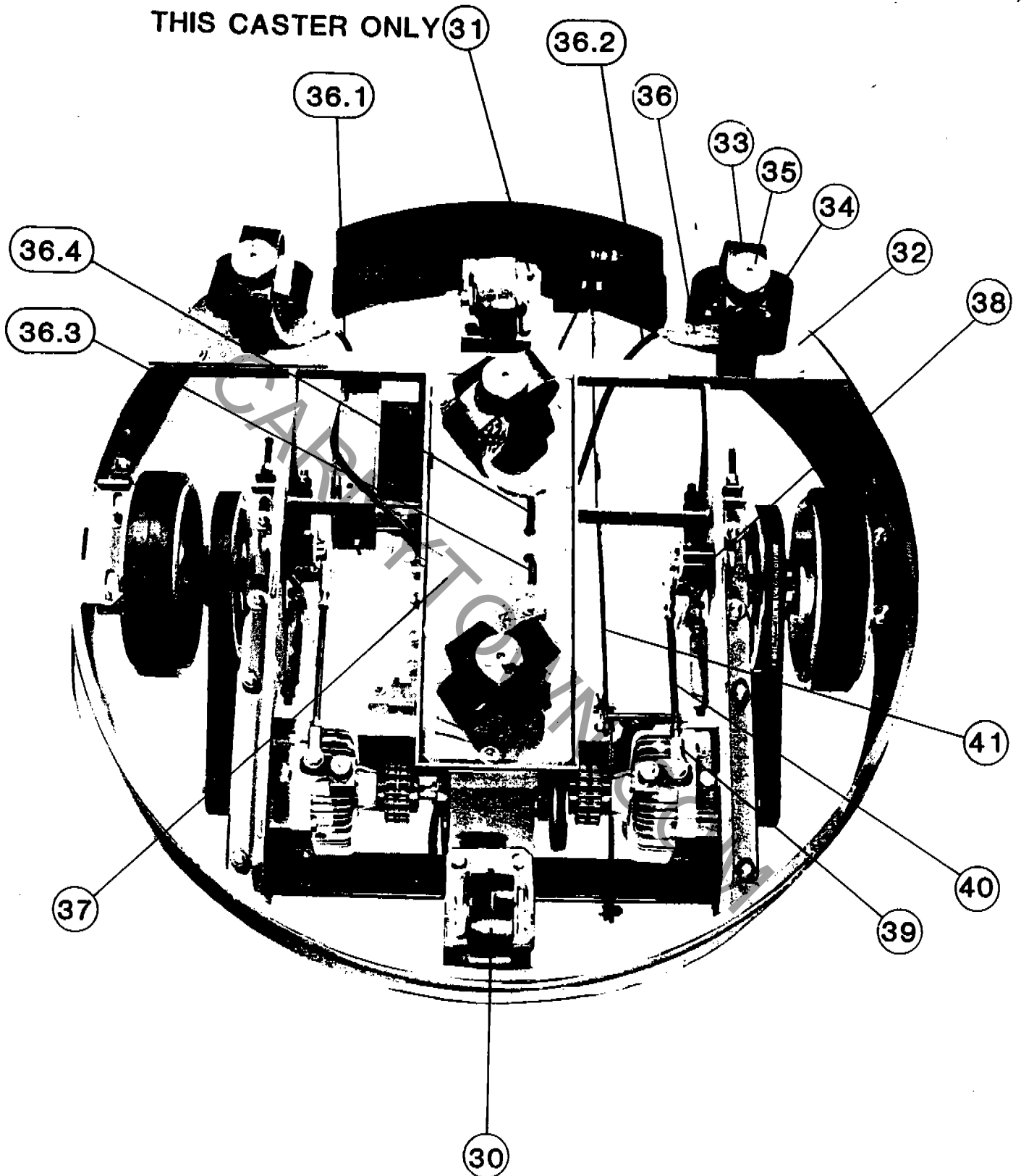

CARNYTOWN.COM

COMPONENT IDENTIFICATION

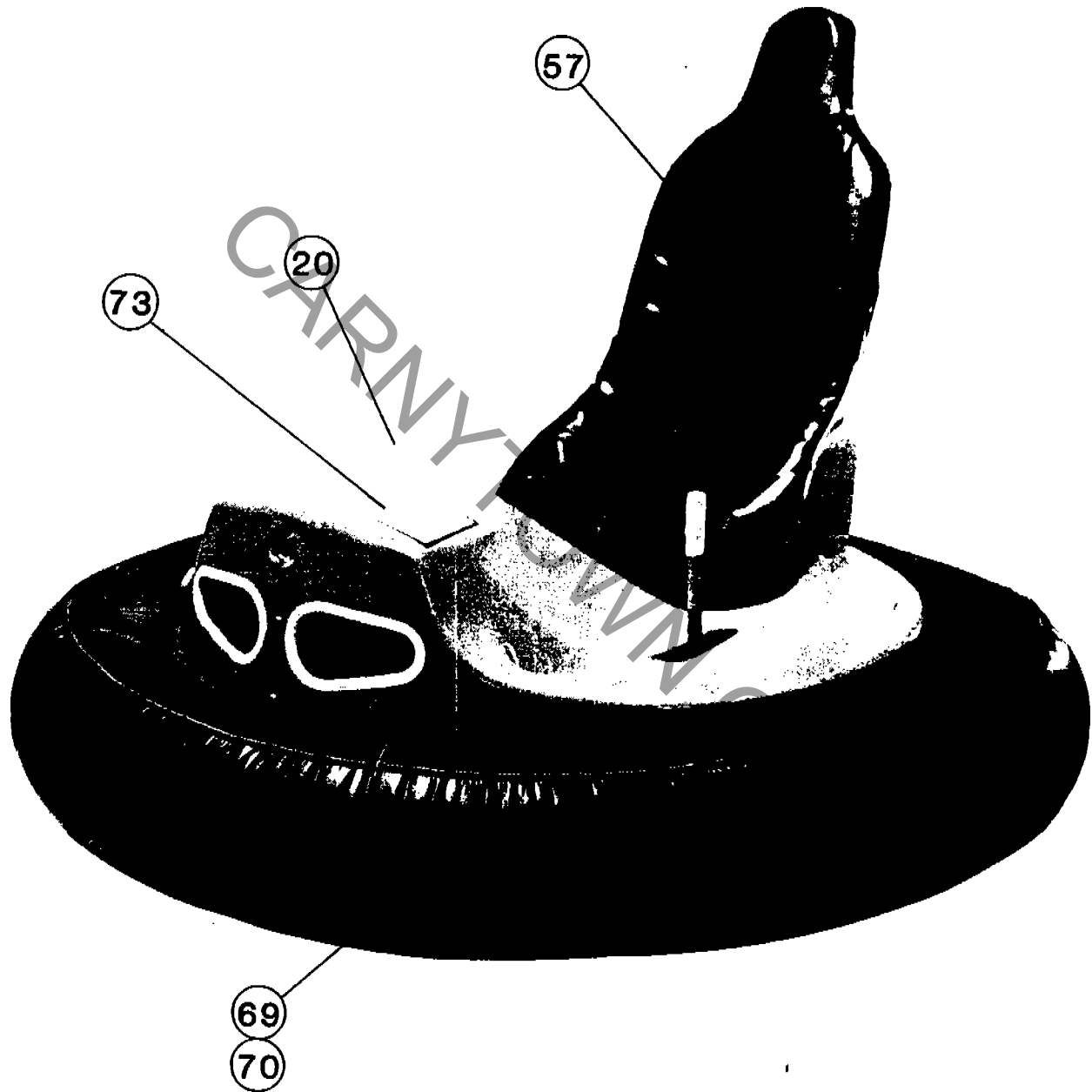

TRANSMISSION CARRIER ASSEMBLY

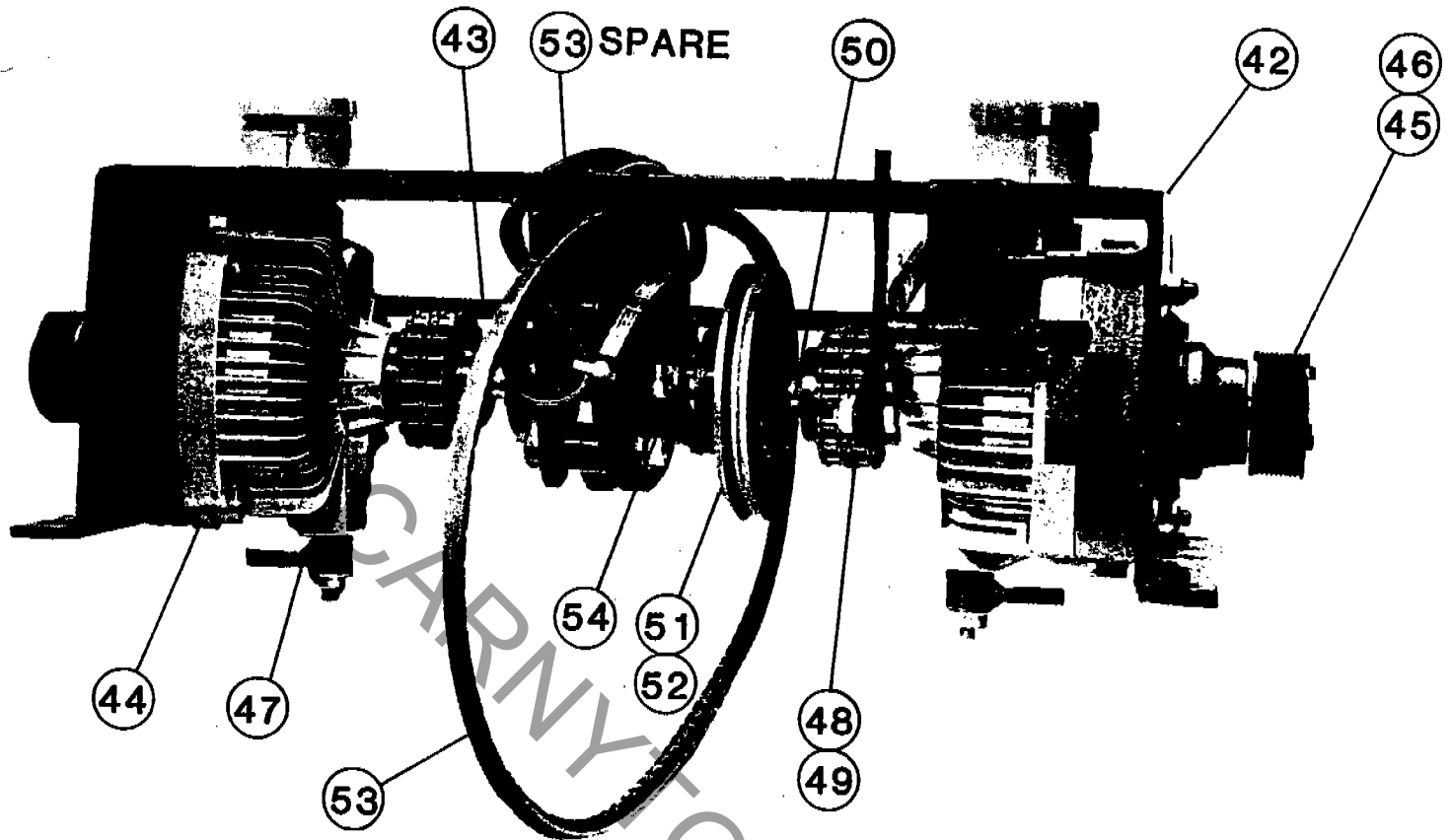

REF NO	PART NO	NAME OF PART	NO REQ
42	KC-9	Transmission Carrier	1
43	KC-9-6	Neutral Bar Assembly	1
44		Transmission - Specify	
	KC-1-1	Clockwise	1
	KC-1-2	Counterclockwise	1
		Bolt, $\frac{3}{8}$ - 16NC x 3	8
		Nut, $\frac{3}{8}$ - 16NC Lock	8

REF NO	PART NO	NAME OF PART	NO REQ
45	KC-1-11	Output Sheave	2
46	KC-1-10	Output Sheave Bushing	2
47		Bellicrank - Specify	
	KC-8-2	for CW Transmission	1
	KC-8-1	or CCW Transmission	1
		Washer, $\frac{3}{8}$ Flat	2
		Nut, $\frac{3}{8}$ - 16NC Lock	2
48	KC-1-17	Chain Coupling	2
49	KC-1-28	Coupling Bushing	4
50	KC-1-40	Jack Shaft	1
51	KC-1-16	Jack Shaft Sheave	1
52	KC-1-45	Jack Shaft Bushing	1
53	KC-1-19	Input Belt	1
54	KC-1-15	Pillow Block	2
		Bolt, $\frac{3}{8}$ - 16NC x 3	4
		Nut, $\frac{3}{8}$ - 16NC Lock	4

RECTIFIER ASSEMBLY

REF NO	PART NO	NAME OF PART	NO REQ
23	KC-5-4	Mounting Board	1
		Bolt, 1/4 - 20NC x 3/4	2
		Nut, 1/4 - 20NC Lock	2
24	KC-5-8	Conductor Strip	8
		Bolt, 1/4 - 20NC x 1	8
		Washer, 1/4 Flat	8
		Nut, 1/4 - 20NC	8
		Fuse Link, 100 AMP	4
25	EK-1	Bolt, #10 - 32 x 5/8 Brass	8
		Washer, #10 Brass	8
		Nut, #10 - 32 Brass	8
		Diode Mounting Angle	1
26	KC-5-2	Bolt, 1/4 - 20NC x 3/4	4
		Nut, 1/4 - 20NC Lock	4

REF NO	PART NO	NAME OF PART	NO REQ
27	EK-3	Diode ∇	4
		Nut, 1/2 - 20NF	4
28	KC-5-3	Diode Mounting Bar	1
		Bolt, 1/4 - 20NC x 3/4	4
		Nut, 1/4 - 20NC Lock	4
29	EK-2	Diode Δ	4
		Nut, 1/2 - 20NF	4

