

MFG: JVI INDUSTRIES

NAME: FLY-O-PLANE

Type: Non-Kiddie

FLY-O-PLANE

CARNY-TOWN.COM



JV INDUSTRIES, INC.

P.O. BOX 13399 SALEM, OR 97309-1399

(503) 399-0817

■ FABRICATORS OF STEEL AND FIBERGLASS PRODUCTS ■
■ MANUFACTURER OF AMUSEMENT DEVICES ■

LOCATION OF SERIAL NUMBERS ON FLY-O-PLANE

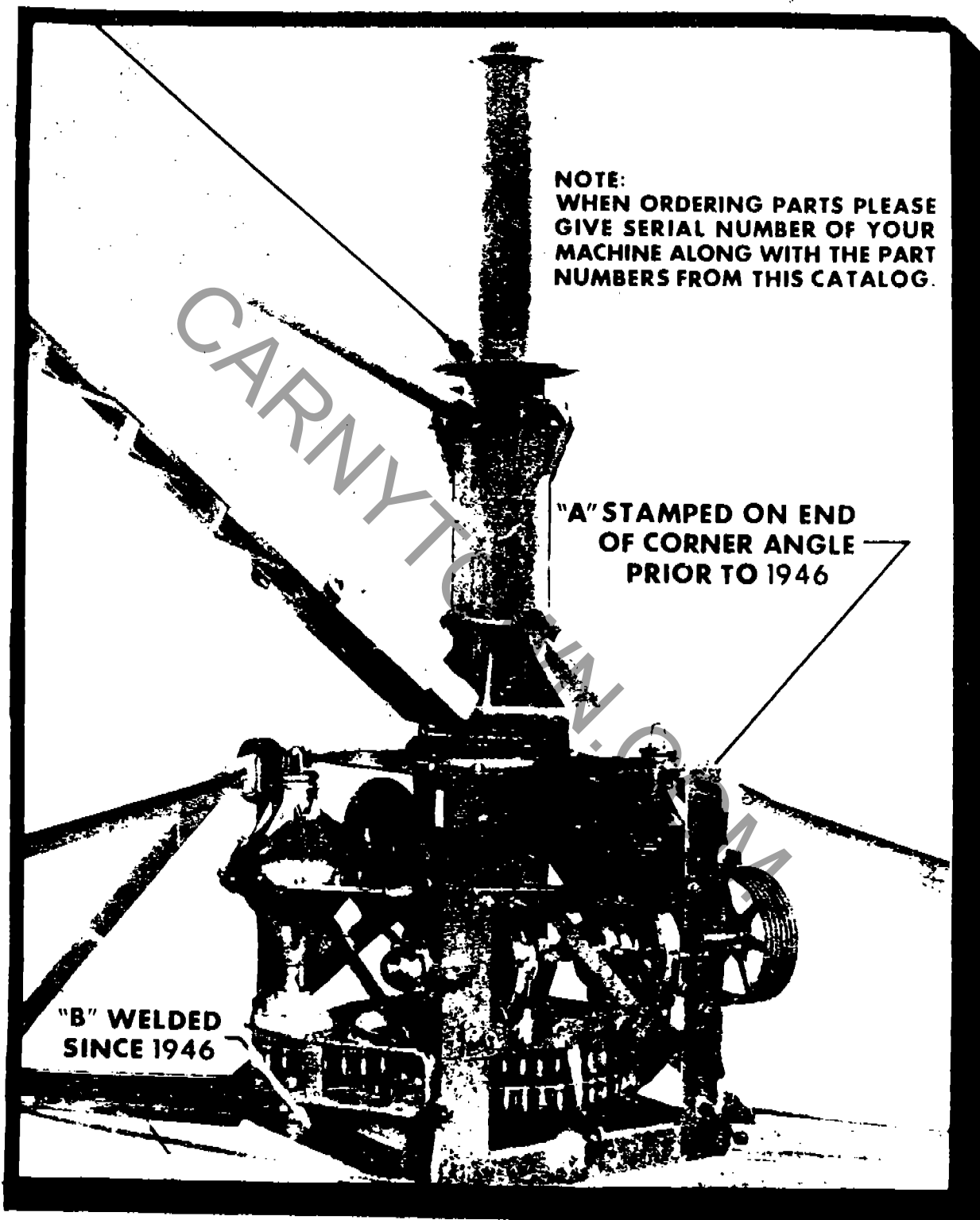

NOTE:
WHEN ORDERING PARTS PLEASE
GIVE SERIAL NUMBER OF YOUR
MACHINE ALONG WITH THE PART
NUMBERS FROM THIS CATALOG.

**"A" STAMPED ON END
OF CORNER ANGLE
PRIOR TO 1946**

**"B" WELDED
SINCE 1946**

**MACHINES BUILT PRIOR TO 1946
HAVE SERIAL NUMBERS 5000 TO
5021. THE SERIAL NUMBER IS STA-
MPED ON THE END OF A CORNER
ANGLE OF THE CAGE. SEE ("A")**

**MACHINES BUILT DURING AND
AFTER 1946 HAVE SERIAL NUMB-
ERS 5500-UP. THE SERIAL NUMB-
ER IS WELDED ON THE BOTTOM
CHANNEL OF THE CAGE. SEE ("B")**



FLY-O-PLANE SPACE REQUIREMENTS

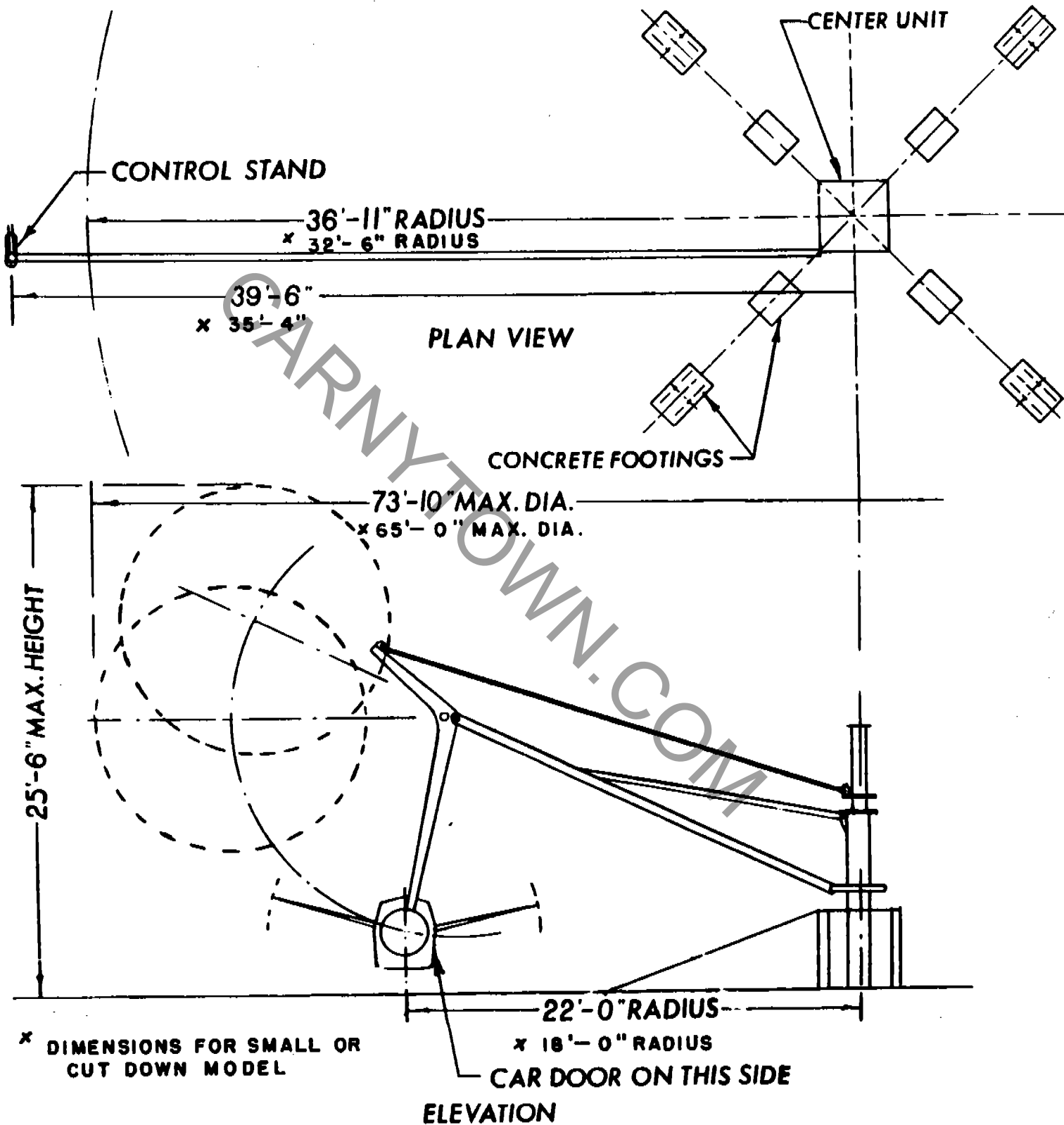

Place a 1-1/4" Conduit from the control stand to the center unit for the light circuit. If the ride is Electric Motor driven place a 1-1/4" Conduit for power circuit also. Conduit for the light and power input should be brought to the control stand.



CONCRETE FOOTINGS FOR OCTOPUS & FLY-O-PLANE

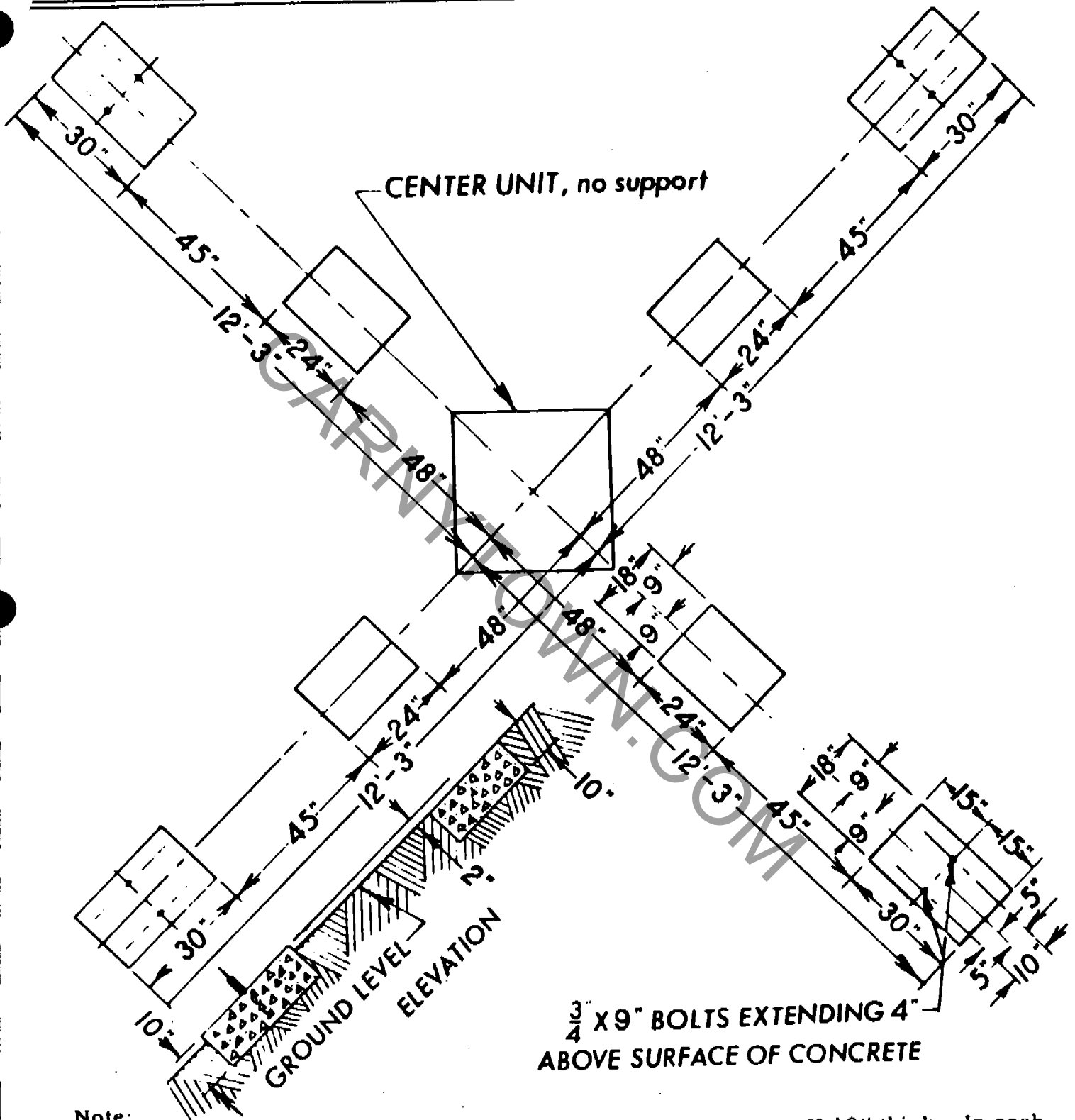

Note:

The four outer footings are concrete slabs 18" wide X 30" long X 10" thick. In each outer footing imbed two $\frac{3}{4}$ " X 9" bolts with 4" extending above the surface of the concrete. These bolts should be on 10" centers (5" each side of center line) and 15" from each end. Hold down sills with lugs on these bolts.

The intermediate footings are concrete slabs 18" wide X 24" long X 10" thick.

The elevation of the four outer footings should be two inches higher than the four intermediate footings.



LUBRICATION INSTRUCTIONS

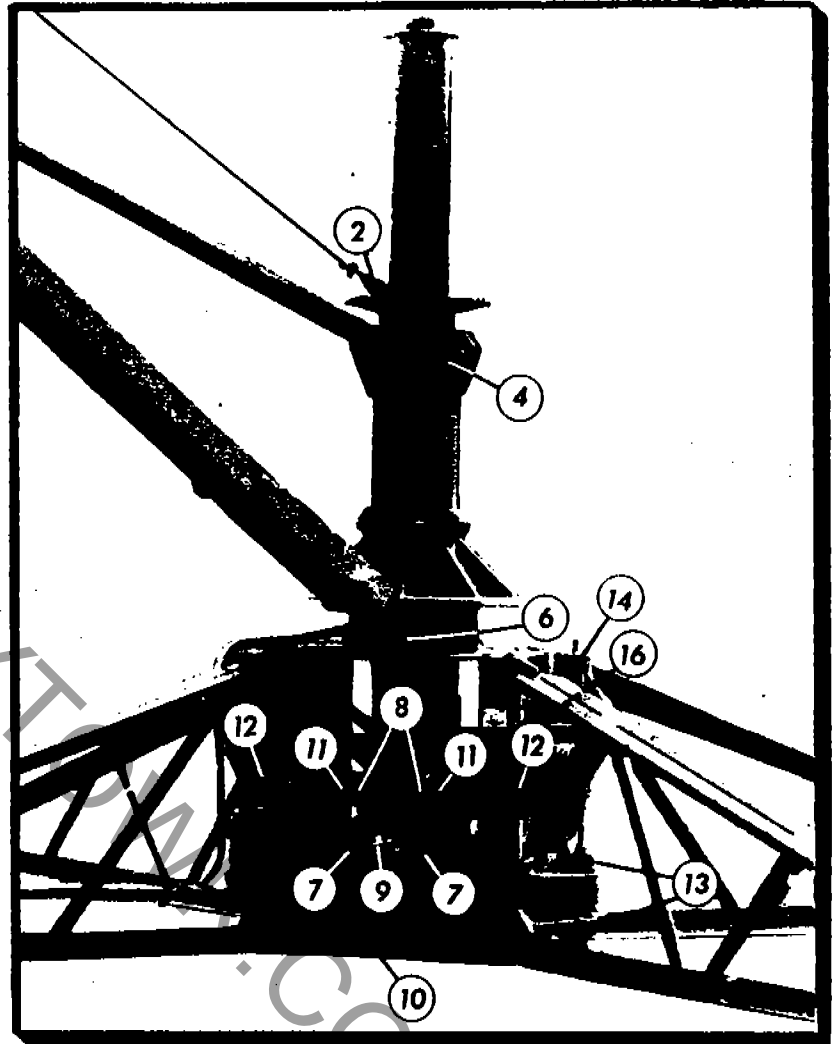
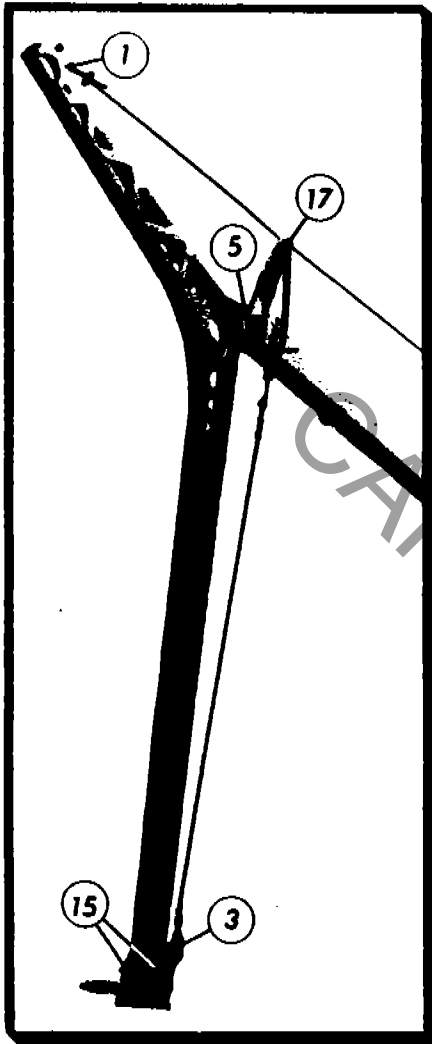

NAME OF PART	TYPE OF BEARING *
1 CAST IRON LIFT CABLE THIMBLE	BRONZE (A)
2 BRONZE LIFT CABLE THIMBLE	BRONZE (A)
3 BRONZE LEVELING CABLE THIMBLE	BRONZE (A)
4 INNER COLUMN BUSHING	BRONZE (A)
5 OUTER ARM HINGE PIN BUSHING	BRONZE (A)
6 SPLIT HUB BUSHING	BRONZE (A)
7 CLUTCH THROWOUT BUSHING	BRONZE (A)
8 CLUTCH SHIFTER RING BEARING	ANTI-FRICTION (A)

NAME OF PART	TYPE OF BEARING *
9 UPPER BASE BEARING	ANTI-FRICTION (A)
10 LOWER BASE BEARING	ANTI-FRICTION (A)
11 CLUTCH BOWL BEARING	ANTI-FRICTION (B)
12 COUNTERSHAFT BEARINGS	ANTI-FRICTION (C)
13 DRIVE SHAFT BEARINGS	ANTI-FRICTION (C)
14 GEAR CASE UPPER BEARING	ANTI-FRICTION (A)
15 CAR SPINDLE BEARINGS	ANTI-FRICTION (C)
16 GEAR CASE	ANTI-FRICTION (D)
17 LEVELING CABLE SPRING HOUSING	BRONZE (E)

*LUBRICATION INTERVAL: THE ABOVE TABLE OF LUBRICATION INTERVALS REFER TO AVERAGE OPERATING CONDITIONS WITH GREASE SEALS INTACT.

(A) DAILY OR EVERY EIGHT HOURS DURING HEAVY OPERATIONS.** PRESSURE FITTINGS.

(B) LIGHTLY EVERY TWO WEEKS.**

(C) EVERY THREE MONTHS.**

(D) CHECK EVERY MONTH. CHANGE EVERY YEAR. USE E. P. 90 GEAR LUBE.

(E) KEEP ALL MOVING PARTS OILED DAILY.

NOTES:

** USE A MULTI-PURPOSE WATER RESISTANT GREASE WITH AN ACCEPTED EXTREME PRESSURE ADDITIVE SUCH AS CHEVRON R. P. M. MOLYGREASE NO. 1 OR MOBIL GREASE SPECIAL IN ALL

LUBRICATE DRIVE CHAINS EVERY TWO WEEKS WITH AN APPROVED LUBRICANT SUCH AS ROTANIUM POWER-LUBE NO. 91665, CHEVRON PINION GREASE MS OR EQUIVALENT.

KEEP LIGHT RINGS CLEAN AND FREE OF CONTAMINANTS SUCH AS GREASE, OIL ETC.

CHANGE OIL IN HYDRO-SHEAVE EVERY 4000 HOURS OR ONCE A YEAR. USE 10W ABOVE 10 DEGREE F. & 5W BELOW 10 DEGREE F. OIL IS TO BE HEAVY DUTY TO MEET A. P. I. SERVICES CLASS M. S.

REFER TO THE ALLIS-CHALMERS OPERATING & MAINTENANCE MANUAL FOR SERVICE OF G-130 GAS ENGINE.



ASSEMBLY & OPERATION INSTRUCTIONS

for

FLY-O-PLANE

First spot your center assembly where you wish to assemble the ride, attach all mud sills, being sure you have the proper sill located next to the countershaft V-Belt pulley. You will note the brace in this sill has been shifted to allow room for the V-Belts. Attach diagonal brace rods to the mud sills. Block up mud sills so that the bulk of the weight comes near the tips of the mud sill. This will prevent any tendency for the ride to weave.

Next attach one of the straight sweep arms to center piece with U-Bolts furnished for this purpose. Do not pull nuts tight until arms are all up into position. With outer end of sweep resting on ground, attach outer sweep arm to straight arm with pin, (F-153), being sure that nuts are pulled up good and tight as well as lock nut.

Insert car spindles (F-151), into the bearings on the outer arms, and lock in place by rotating the ring (RR-97-F), against the face of the bearing on the car side until it stops; then tighten its set screw. Attach car leveling cable, (F-276), to the eccentric on car spindle and lock by means of the snap ring (F-189). A special pair of pliers are provided in the parts box for this purpose. Attach the other end of this cable to eye bolt (F-275), which extends into Car Leveling Spring Housing, (F-274). Attach this Car Leveling Spring Housing, to the upright arm on the inner sweep arm by means of bushing, (F-293), sleeve, (F-185), and bolt (F-186). Attach the lift cable, (F-191), to the outer arm, (F-163), with pin, (F-132). Next, attach the other end of lift cable to the drum flange, being sure that all bolts, nuts, and cable clamps are tight and that the cotter pins are in the cable swivel bolts, (F-82).

Attach block and tackle to center drum near its upper end, hooking the other end about two-thirds of the way out on the straight sweep, then pull the arm up to a height required to fasten the support tube to the ear on the center column by means of the tapered pin, (O-26). Assemble the arms on the ride alternately from side to side so as to keep it approximately balanced. When all sweeps have been locked into position, the diagonal bracing between the sweep arms should be pulled snug, but not too tight.

Next attach the cowling, or nose piece, to the arm followed by the car on the car spindle which is locked in its proper position on the shaft with the key washer (RR-96-A). Tighten the jam nut (RR-97-B) on top of the nut (RR-97-A). Attach wings, tail surfaces and tail pipes. Clamp the wings in a horizontal position when the control wheels are in a neutral position. Locate and attach the power unit and control stand.

BEFORE STARTING YOUR FLY-O-PLANE:

Lubricate and check the cable swivels, both on the center drum flange and on the car righting eccentric. They must be free to rotate.

Lubricate the entire ride as per the lubrication chart.

Adjust the car righting cable so all slack is removed when the outer arm is in a vertical position. Readjustment of the cable maybe necessary after the ride has been in operation for some time.

Be sure all passengers are securely belted in.

With motor speed sufficient to turn the ride at about 11-1/2 revolutions per minute, ease the rotation clutch in slowly to allow the ride to start rotating very slowly. As soon as the ride has started to move, pull drum clutch in slowly and carefully, then allow it to wind the cars up to the desired height, at which position you pull the rotation clutch in securely. This locks the two motions together and the ride rotates at this elevation until such time as you are ready to stop it.

Be sure not to elevate cars any higher than altitude reached by having inner and outer sweep in alignment. A yellow band is painted on the top of the cable drum to show the operator how high the cable should be wound. A higher elevation places undue stress on equipment and is not desirable, nor necessary, to perform a good ride. To lower passengers to the ground and stop them, simply release the drum clutch, holding the drum stationary with the brake and close the throttle on the engine so that by the time the cars reach the ground they are practically at a standstill. A small cable is furnished which reaches from the foot pedal on the control stand to a special lever arrangement on the engine governor. To obtain the proper rotation speed, (11-1/2 R.P.M.), the throttle on the engine can be adjusted with a turnbuckle in the throttle cable.

The preceding paragraph referred to the power unit as being a gasoline engine. Where an electric motor is to be used, the procedure differs only in lowering the cars. As the electric motor will offer practically no braking effect, the rotation must be stopped with the brake as the cars reach the ground.

For added safety in the operation of this ride, it should be kept rotating from the time the cars leave the ground until they land again. In other words, do not stop the ride while the cars are in mid air.

WARNING:

DO NOT, UNDER ANY CIRCUMSTANCES, ROTATE THE RIDE AT A HIGH RATE OF SPEED WHILE THE CARS ARE NEAR THE GROUND. Centrifugal force is great enough to swing the arm out loosening the lift cable, allowing the cable to tangle on the swivels and kink which will cause an early cable failure.

WARNING:

NEVER ALLOW THE CENTER DRUM TO SPIN WITH THE CLUTCH IN NEUTRAL WHICH ALLOWS THE CARS TO DROP VERY RAPIDLY. When the cars are in the air with the ride rotating, the clutch should either be engaged or the brake applied. The transfer from the clutch engagement to brake application must be made quickly and positively.

CHAIN ADJUSTMENTS

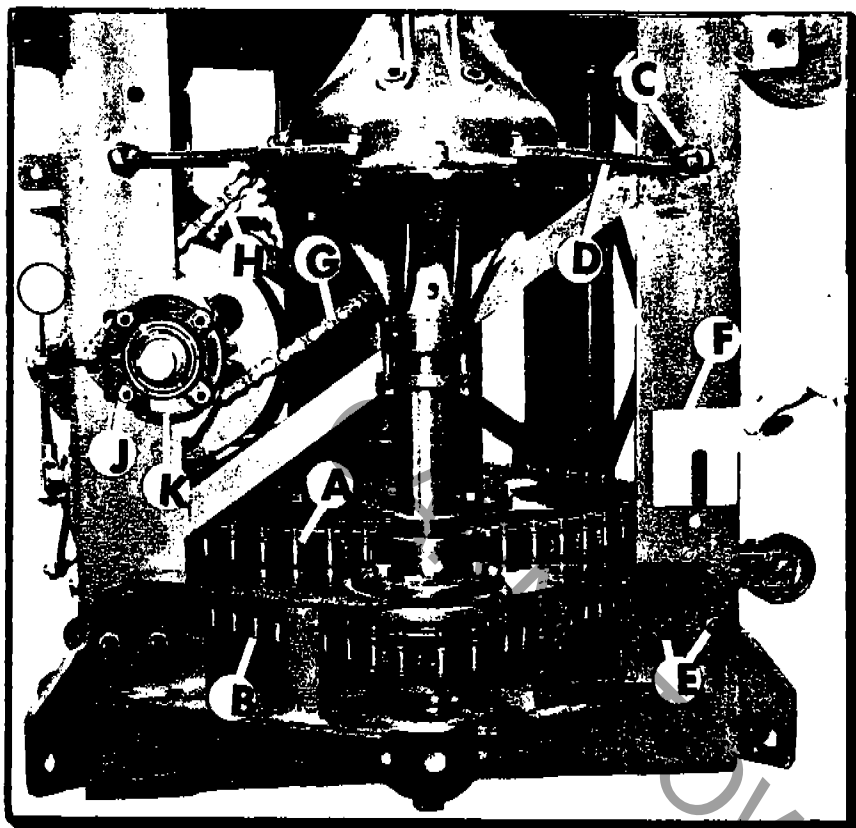

FIG. 1

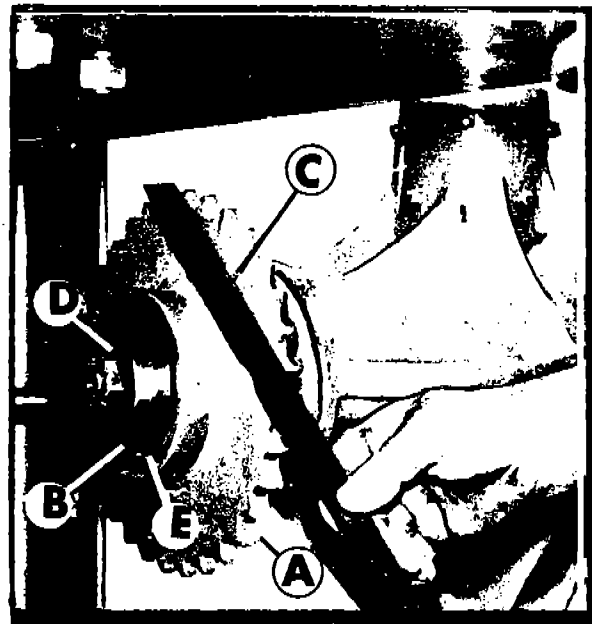

FIG. 3

Chains (A) & (B) Figs. 1 & 2 are adjusted by loosening the nuts (C) on the studs of the gear housing bracket (D) and the nuts on the same studs that are on the inside of the corner angles. Then loosen the nuts (E) on all four gear drive support bracket bolts. Pry the bracket (D) away from the corner angles and insert the proper number of spacers (F) Fig. 1 to remove all slack in the chain and then tighten nuts (E). Adjust and tighten nuts (C) until the driving sprocket is in horizontal alignment with the driven sprocket, or in vertical alignment with the corner angles.

Driving sprocket (A) Fig. 3 is aligned with driven sprocket by loosening taper-lock bushing (B) and aligning the sprockets by means of the straight edge (C). When alignment is completed, lock taper-lock bushing (B) to hub (D) by means of set screws (E).

To adjust chains (G) & (h) loosen the nuts (J) on both countershaft bearings (K) and tighten chains by means of nuts (L). They are properly adjusted when they can be depressed 3/4" with one finger midway between sprockets. When adjustment is completed, tighten nuts (J).

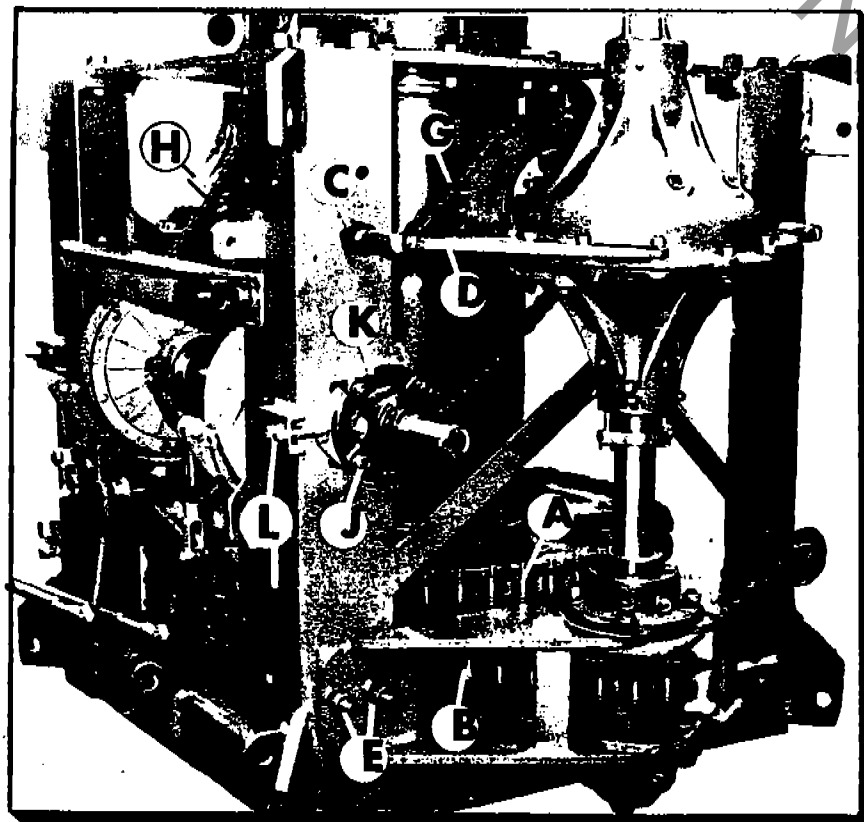

FIG. 2



COUNTERSHAFT SPROCKET ALIGNMENT (FOR BOLTED DRIVEN SPROCKET (A) FIG. 3)

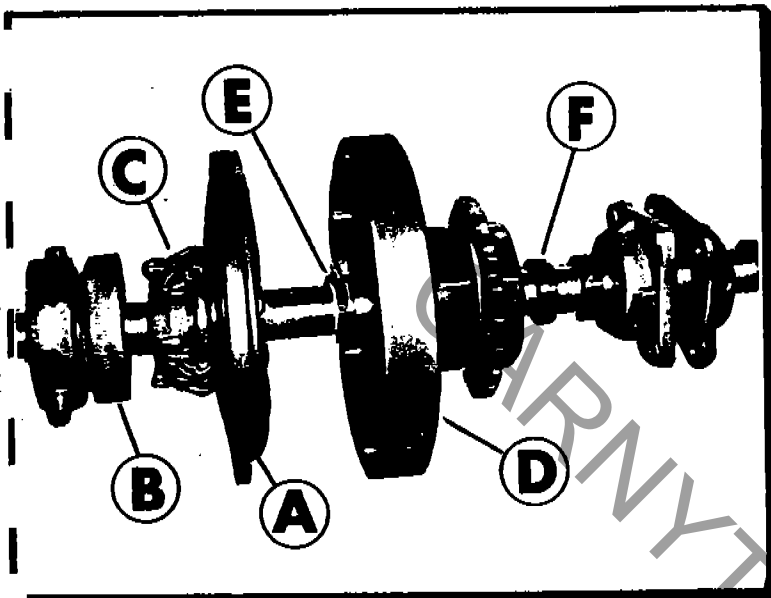

FIG. 1

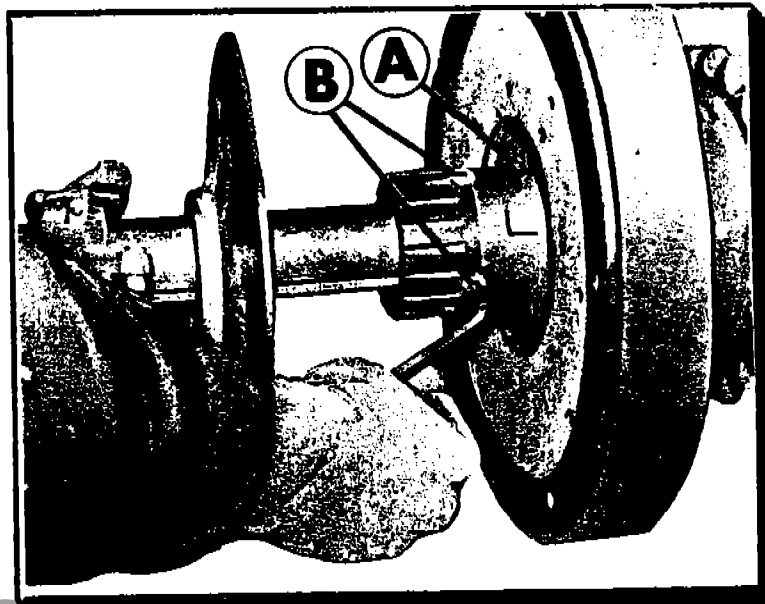

FIG. 2

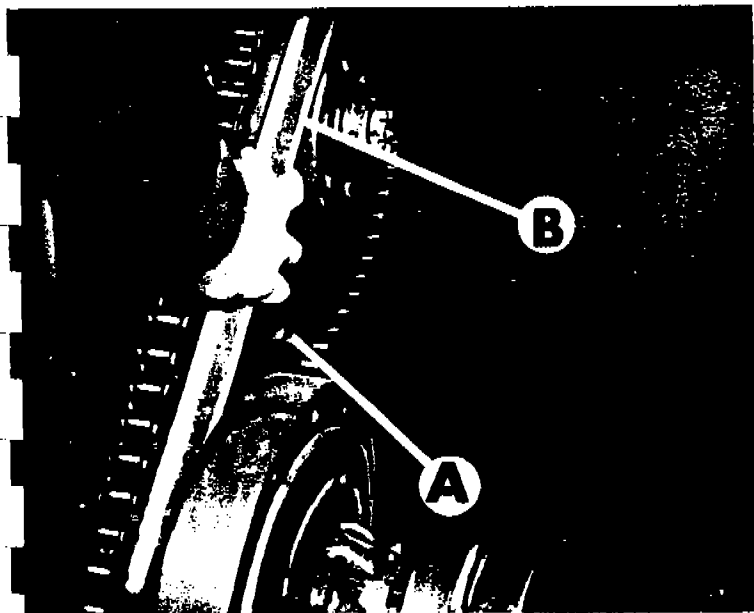

FIG. 3

The alignment of this sprocket is accomplished by moving the clutch on the countershaft. To do this, it is necessary to loosen the set screws which secure the clutch body (A) Fig. 1 to the countershaft. First, slide the shifter assembly (B) Fig. 1 away from the clutch body and remove the finger assembly (C) by unscrewing it from the clutch body. Next, loosen the set screws, see Fig. 2, and slide the clutch body away from the clutch bowl (D) so the inside locking collar (E) Fig. 1 may be removed. This inside collar was not used on some of the early models. The inner and outer collars (E) and (F) Fig. 1 are removed by releasing the set screws and rotating them with a spanner wrench, or with a punch inserted in the hole in the collar.

The clutch bowl may now be moved on the countershaft and aligned with the driven sprocket (A) Fig. 3 by use of a straight edge (B) Fig. 3.

When alignment is completed, replace the locking collars by rotating them on the ends of the bearings until they are tight and securing them with the set screws.

Check the springs (A) Fig. 2 for tension and make sure they are all in place. Re-assemble the clutch body (A) Fig. 1 and secure it to the countershaft by tightening the two set screws (B) Fig. 2. Replace the finger assembly and adjust as per instructions outlined in "CLUTCH ADJUSTMENT"

CLUTCH ADJUSTMENTS

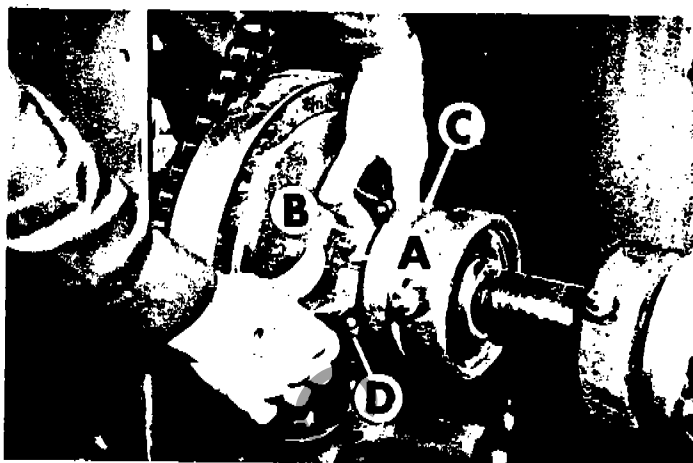

FIG. 1

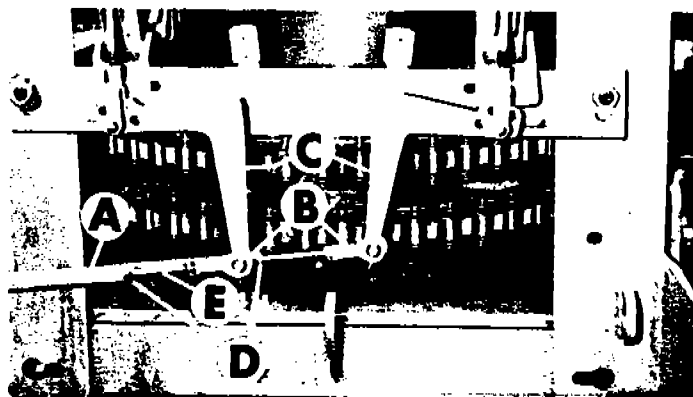

FIG. 2

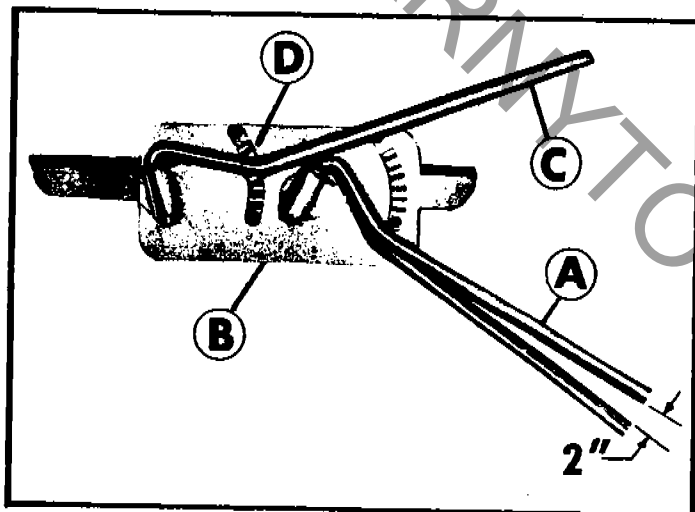

FIG. 3

The clutches are adjusted by depressing the lock lever (A) as shown in Fig. 1, and rotating the clutch finger assembly (B) in a clockwise direction, facing the clutch, to tighten and in a counter-clockwise direction to loosen. They should be adjusted to where it requires some leverage to engage them and should feel and hear a definite snap as the rollers engage the recess in the cam. Be sure the lock lever (A) drops into the slot when adjustment is completed.

The clutch control rods (A) Fig. 2 are adjusted by removing the clutch control rod ends (B) from the levers (C) and, with the control handle (A) Fig. 3, on the control stand (B) in a position about two inches from the extreme back position as shown in Fig. 3 and with the clutch engaged, release the lock nuts (D) Fig. 2, adjust the clutch control rod end studs (E) in or out until the rod ends (B) align with the pins on lever (C). Complete the adjustment by mounting the rod ends (B) on the pins on levers (C) inserting the cotter keys and tightening lock nuts (D).

BRAKE ADJUSTMENTS

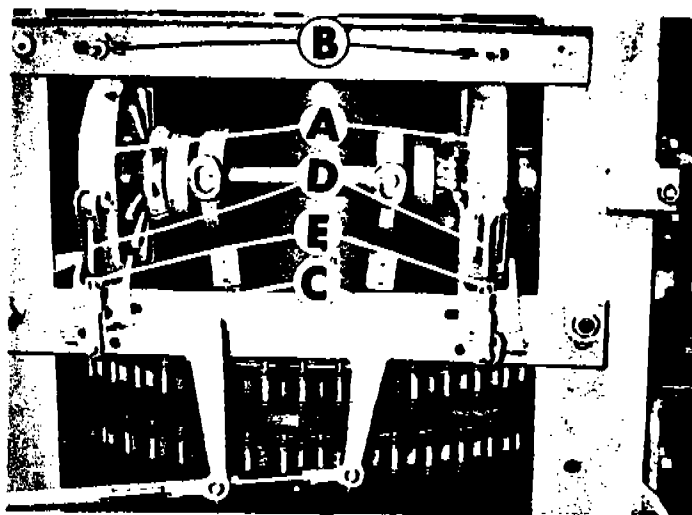

FIG. 4

The brakes (A) Fig. 4 are adjusted by means of the nuts (B). The adjustment should be such that, with the control handle (C) Fig. 3 in the center segment of ratchet (D), the brakes are set. As the brakes wear and no further adjustment can be made with nuts (B), further adjustment may be made by disconnecting clevis (C) Fig. 4 and unscrewing it on brake rod (D). However, when this adjustment is employed, never go beyond the point where less than four or five threads of the brake rod (D) are engaged in the clevis (C). When the adjustment is completed, be sure to tighten lock nut (E). Replace the brake lining on the band before the rivets score the drum.



FLY-O-PLANE PARTS CATALOG

CENTER CAGE ASSEMBLY

PART NO.	NAME OF PART	NO. REQ.	PART NO.	NAME OF PART	NO. REQ.
0-26	PIN, Universal, taper	16	0-166-B	ROLLER CHAIN, (54 tooth driven sprocket)	2
0-28	KEY, inner column hub	2	F-168	COLUMN, inner	1
0-37	BUSHING, inner column	1	0-277	GUIDE, brake band	2
0-37-A	ZERK, inner column bushing	1	0-280	BRACKET, brush carrier	1
0-38	LIGHT RING	2	0-281	BRUSH FINOER ASSEMBLY	1
0-46-A	BOLT & INSULATION, light ring	4	0-290	ROLLER, cage (large)	2
0-62-A	CAGE ASSEMBLY	1	0-291	PIN, large cage roller	2
0-63	PLATE, upper cage	1	0-293	ROD, brake	2
0-63-A	BOLT, upper cage plate	12	0-293-A	PIN, brake rod	4
0-75-A	SPLIT HUB	1	0-294	CLEVIS, brake rod	2
0-75-B	BUSHING, split hub	1	0-295	BAND, brake	2
0-76	BOLT, split hub (clamping)	4	0-295-A	NUT, brake band	4
0-78	BOLT, split hub flange	14	0-295-B	LINING, brake band	2
F-81	FITTING, cable	8	0-299	CLUTCH THROW-OUT ASSEMBLY	1
0-81	BOLT, cage brace	4	0-299-A	BOLT, clutch throw-out assembly	2
F-82	BOLT & SLEEVE, cable fitting	8	0-300	ANGLE, brake rod support	1
0-82	ROLLER, cage (small)	2	0-300-A	BOLT, brake rod support angle	2
0-83	PIN, small cage roller	2	0-307	BEARING, inner column	2
0-108	NUT, gear drive adjuster	8	0-308	LOCK RING, inner column bearing	1
0-131	SPACER, gear drive support	12	0-309	HUB, inner column	1
0-133	BRACKET, gear drive support	2	0-309-A	BOLT, inner column hub	2
0-133-A	BOLT, gear drive support bracket	8	0-394	BRACE, cage (front)	1
F-166	COLUMN, outer	1	0-395	BRACE, cage (right)	1
0-166	SPROCKET, 54 tooth driven	2	0-396	PLATE, inner column grease retainer	1
0-166-A	BOLT, 54 tooth driven sprocket	20	0-397	SHIELD, inner column bearing	1

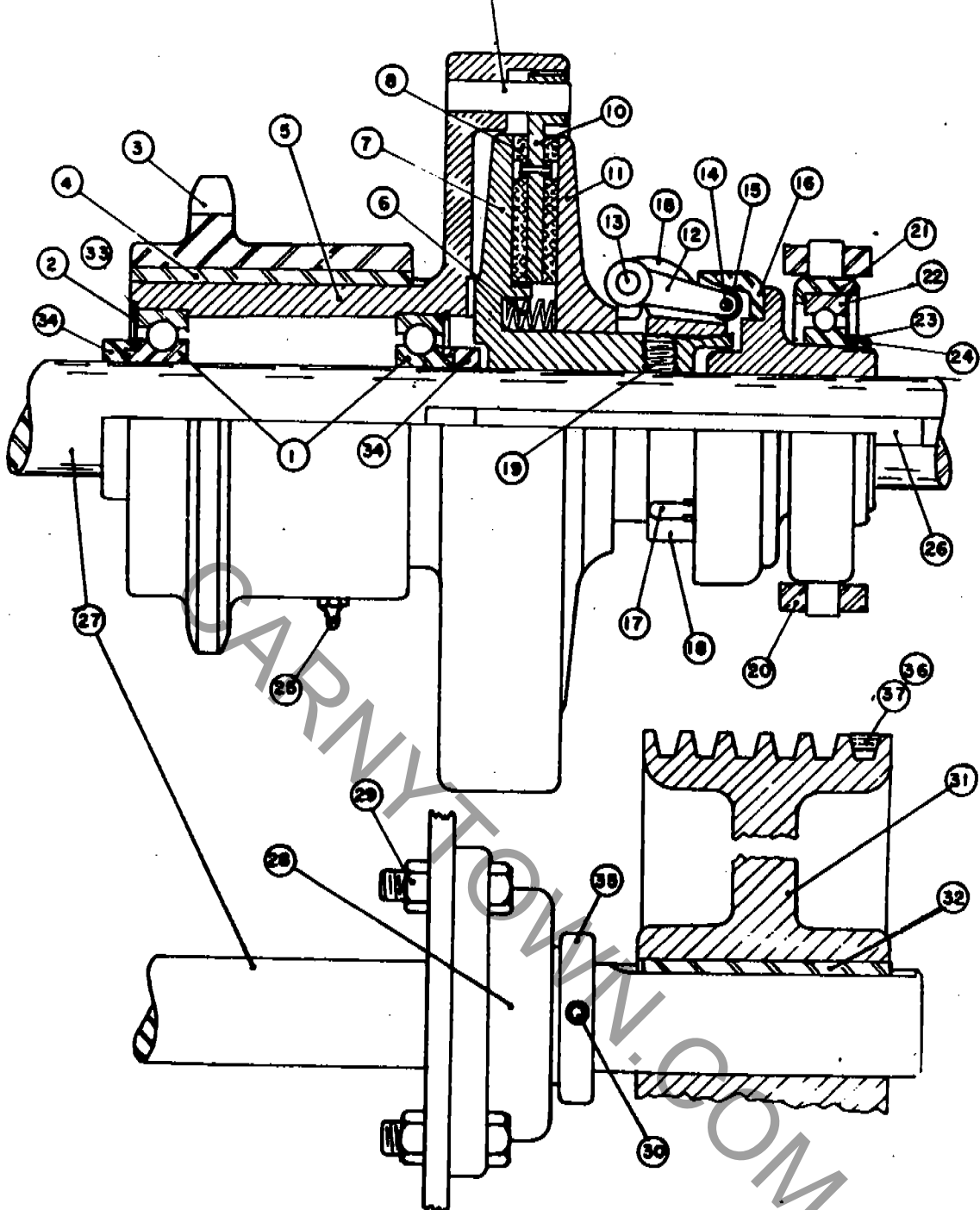

EDGEMONT CLUTCH & COUNTERSHAFT

REV No.	NAME OF PART	PART No.	No. REQ.
1	BOWL BEARING	0-251	4
2	GREASE WASHER	0-252	4
3	CLUTCH HUB	0-253	2
4	CLUTCH HUB KEY	0-254	2
5	BOWL	0-255	2
6	RELEASE SPRING	0-256	6
7	BODY	0-257	2
8	LINING	0-258	4
9	DRIVE PIN	0-259	8
10	DISK	0-260	2
11	PLATE	0-261	2
12	LEVER	0-262	6
13	LEVER PIN	0-263	6
14	ROLLER PIN	0-264	6
15	ROLLER	0-265	6
16	CAM	0-266	2
17	LOCK LEVER, SPRING AND PIN ASSEMBLY	0-267	2
18	ADJUSTER ASSEMBLY	0-268	2

REV No.	NAME OF PART	PART No.	No. REQ.
19	SET SCREW	0-269	4
20	SHIFTER YOKE	0-270	4
21	SHIFTER RING	0-271	4
22	SHIFTER RING BEARING	0-272	2
23	WASHER	0-273	2
24	LOCK NUT	0-274	2
25	ZERK FITTING	0-275	2
26	CLUTCH KEY	0-141	2
27	COUNTERSHAFT	0-134	1
28	COUNTERSHAFT BEARING	0-140	2
29	COUNTERSHAFT BEARING BOLT	0-140-A	8
30	COUNTERSHAFT BEARING SET SCREW	0-140-B	4
31	COUNTERSHAFT PULLEY (V-BELT)	0-138	1
32	COUNTERSHAFT PULLEY KEY	0-142	1
33	BOWL BEARING LOCK RING	0-465	4
34	BOWL BEARING LOCK COLLAR	0-466	4
35	COUNTERSHAFT BEARING LOCK COLLAR	0-467	2
36	B-75 "V" BELT (ELECTRIC)	0-139-A	6
37	B-112 "V" BELT (GAS)	0-139-B	6



FLY-O-PLANE PARTS CATALOG

GEAR DRIVE ASSEMBLY

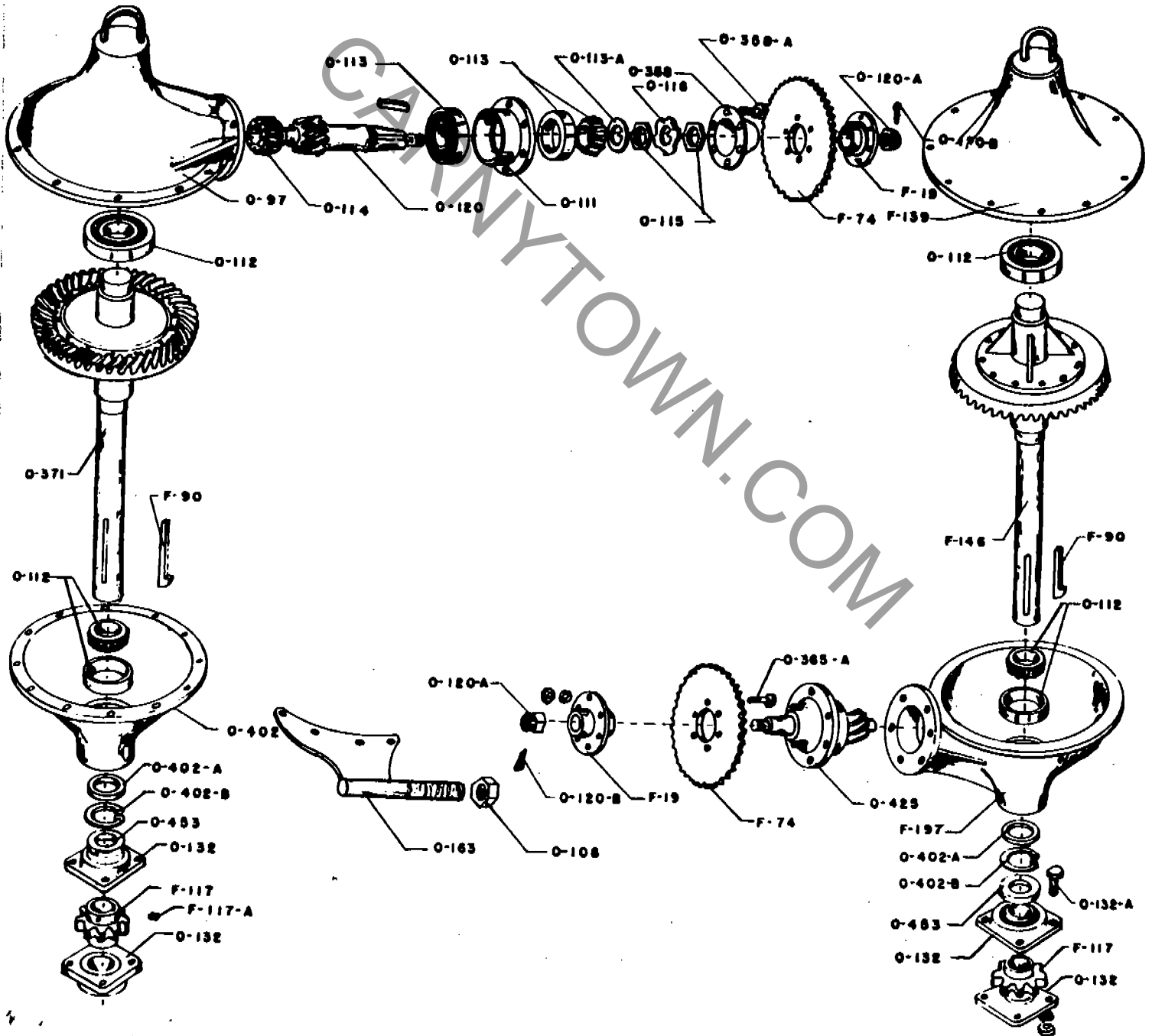



FLY-O-PLANE PARTS CATALOG

GEAR DRIVE ASSEMBLY		
PART NO.	NAME OF PART	NO. REQ.
F-19	HUB, Pinion	2
F-74	SPROCKET, Gear Drive Driven	2
F-90	KEY, Driving Sprocket	4
0-97	HOUSING, Gear Drive Upper, (Left)	1
0-108	NUT, Gear Drive Adjusting	8
0-111	SLEEVE, Pinion	2
0-112	BEARING, Ring Gear	4
0-113	BEARING, Pinion	4
0-113-A	WASHER, Pinion Bearing	2
0-114	BEARING, Pinion Pilot	2
0-115	NUT, Pinion Bearing	4
0-116	LOCKWASHER, Pinion Bearing	2
F-117	SPROCKET, Gear Drive Driving	2
F-117-A	SET SCREW, Drive Gear Driving Sprocket	4
0-120	PINION	2
0-120-A	NUT, Pinion	2
0-120-B	COTTER PIN, Pinion Nut	2
0-132	BEARING, Drive Shaft	4
0-132-A	BOLT, Drive Shaft Bearing	16
F-139	HOUSING, Gear Drive Upper, (Right)	1
F-146	SHAFT, Drive, (Right)	1
0-163	BRACKET, Housing	4
F-197	HOUSING, Drive Gear Lower (Right)	1
0-358	PLATE, Pinion Cover	2
0-358-A	CAP SCREW, Pinion Cover Plate	12
0-365-A	BOLT, Drive Gear Driven Sprocket	12
0-371	SHAFT, Drive (Left)	1
0-402	HOUSING, Drive Gear Lower (Left)	1
0-402-A	GREASE SEAL, Drive Gear Lower Housing	2
0-402-B	LOCK RING, Drive Gear Lower Housing Grease Seal	2
0-425	PINION ASSEMBLY	2
0-453	COLLAR, Drive Shaft Bearing	4



COUNTERSHAFT ASSEMBLY

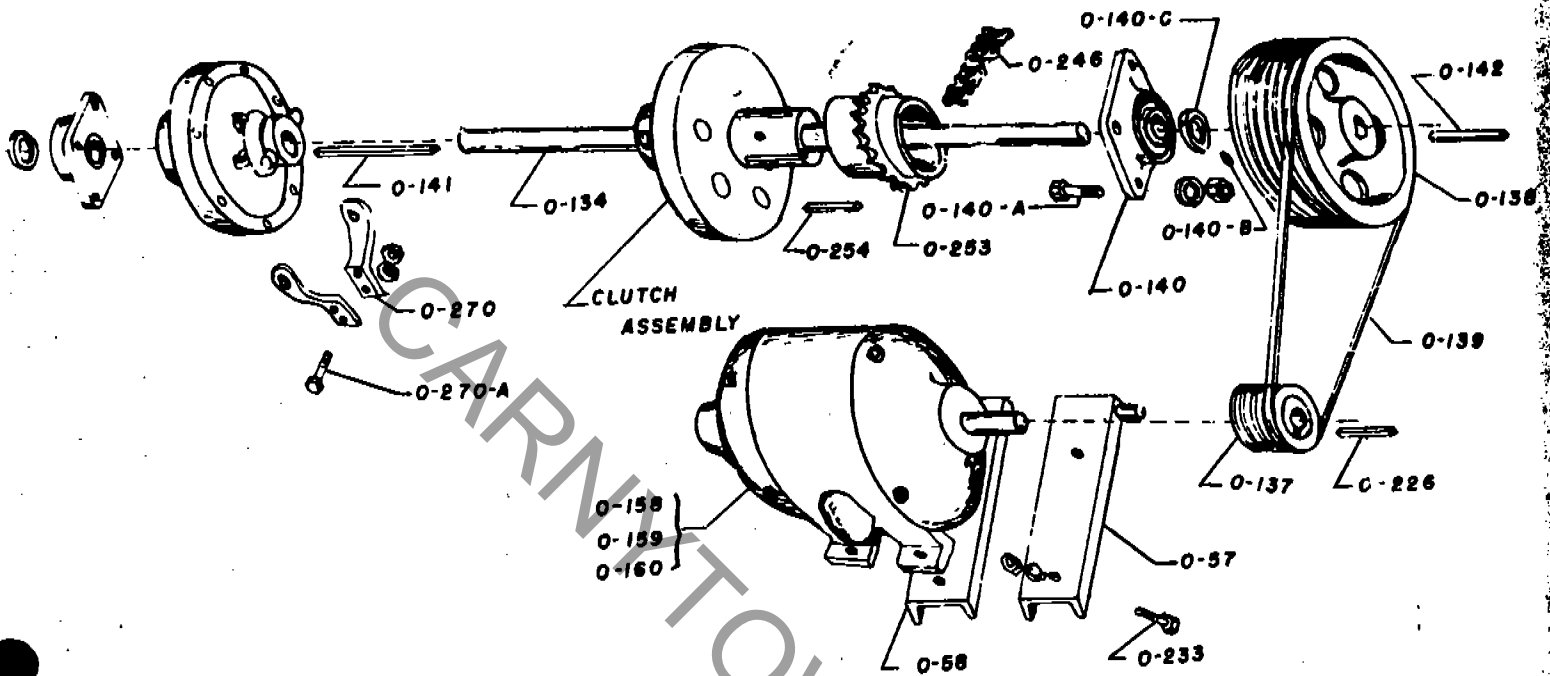

PART NO.	NAME OF PART	REQ. NO.	PART NO.	NAME OF PART	REQ. NO.
O-57	MOTOR MOUNT (RIGHT)	1	O-142	COUNTERSHAFT PULLEY KEY	1
O-58	MOTOR MOUNT (LEFT)	1	O-158	GASOLINE POWER UNIT	1
O-134	COUNTERSHAFT	1	O-159	SINGLE PHASE ELECTRIC MOTOR	1
O-137	MOTOR PULLEY	1	O-160	THREE PHASE ELECTRIC MOTOR	1
O-138	COUNTERSHAFT PULLEY	1	O-226	MOTOR PULLEY KEY	1
O-139	"V" BELT (75" ELECTRIC, 112" GAS)	6	O-233	MOTOR MOUNT BOLT	4
O-140	COUNTERSHAFT BEARING	2	O-246	1" PITCH CHAIN	2
O-140-A	COUNTERSHAFT BEARING BOLT	8	O-253	CLUTCH HUB	2
O-140-B	COUNTERSHAFT BEARING SET SCREW	4	O-254	CLUTCH HUB KEY	2
O-140-C	COUNTERSHAFT BEARING COLLAR	2	O-270	SHIFTER YOKE	4
O-141	CLUTCH KEY	2	O-270-A	SHIFTER YOKE BOLT	4

CARNYTOWN.COM



FLY-O-PLANE PARTS CATALOG

SWEEP ASSEMBLY

PART NO.	NAME OF PART	NO. REQ.
0-26	PIN, Universal tapered	16
F-71	U-BOLT, inner arm	8
F-71-A	NUT, inner arm U-bolt	16
F-81	CABLE FITTING	8
F-81-A	BUSHING, cable fitting	8
F-82	BOLT, NUT & WASHER, cable fitting	8
F-89	CLAMP, cable	32
F-91	THIMBLE, cast iron	8
RR-96-A	LOCKWASHER, car	8
RR-97-A	NUT, car spindle	8
RR-97-B	LOCK NUT, car spindle	8
RR-97-C	BEARING, car spindle	16
RR-97-D	BOLT, car spindle bearing	64
RR-97-E	ZERK FITTING, car spindle bearing	16
RR-97-F	LOCK RING, car spindle bearing	8
F-132	PIN, thimble	8
F-150	THIMBLE, car spindle cable	8
F-151	SPINDLE, car	8
F-153	PIN, hinge	8
F-154	NUT, hinge pin	16
F-155	JAM NUT, hinge pin	16
F-160	ARM, inner	8
F-163	ARM, outer	8
F-175	TUBE, arm support	8
F-183	TURNBUCKLE, car leveling	8
F-185	SPACER, car leveling turnbuckle	8
F-186	BOLT, car leveling turnbuckle	8
F-187	BUSHING, car leveling turnbuckle	8
F-189	LOCK RING, car spindle	8
F-190	CABLE, car spindle	8
F-191	CABLE, lift	8
F-192	TIE ROD, sweep	16
0-387	BUSHING, hinge pin	16
0-412	ORNAMENT, hub	1



FLY-O-PLANE PARTS CATALOG

CONTROL & MUD SILL ASSEMBLIES

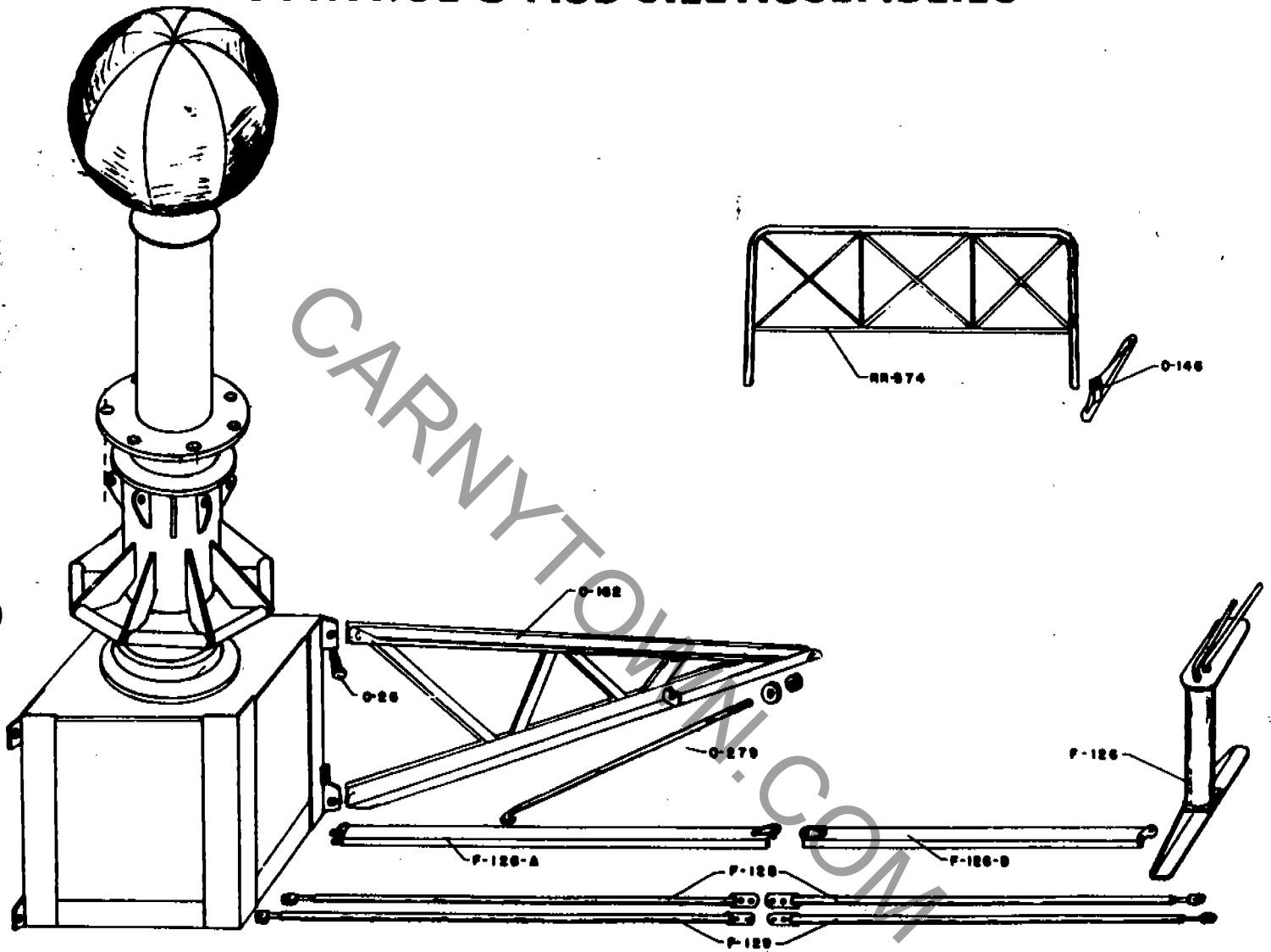

PART NO.	NAME OF PART	NO. REQ.	PART NO.	NAME OF PART	NO. REQ.
F-126	CONTROL STAND	1	O-161	MUD SILL (right front)	1
F-126-A	CHANNEL, control stand inner	1	O-162	MUD SILL	3
F-126-B	CHANNEL, control stand outer	1	O-279	TIE ROD, mud sill	8
F-128	ROD, control (short)	1	RR-373	FENCE SECTION, (short)	2
F-129	ROD, control (long)	1	RR-374	FENCE SECTION (long)	35
O-146	JACK, fence	40			



FLY-O-PLANE PARTS CATALOG

CAR ASSEMBLY

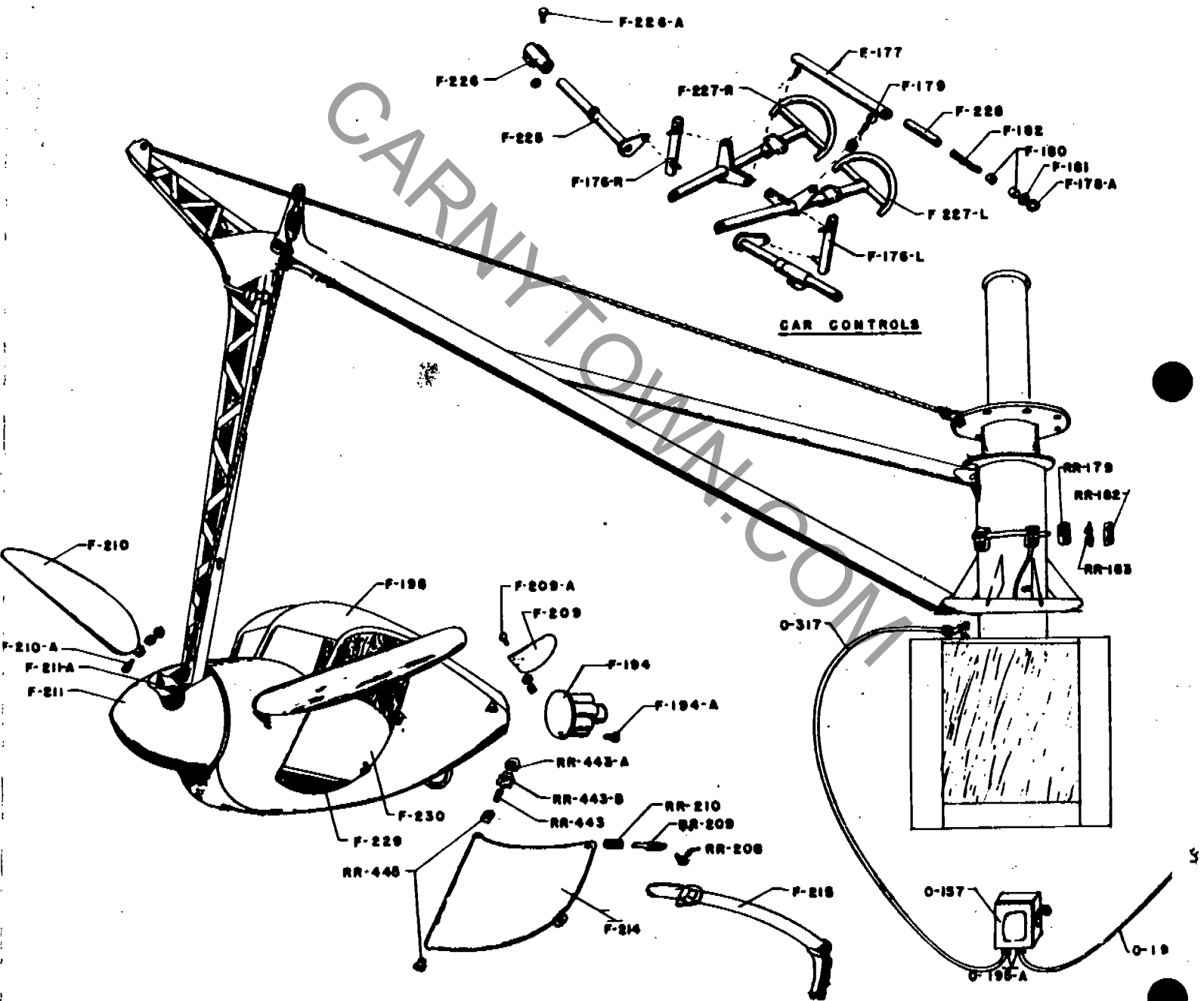



FLY-O-PLANE PARTS CATALOG

CAR ASSEMBLY

PART NO.	NAME OF PART	NO. REQ.	PART NO.	NAME OF PART	NO. REQ.
0-157	SWITCH, light	1	RR-210	SPRING, car door latch	8
F-176-L	LINK, car control (left)	8	F-210	WING, car	16
F-176-R	LINK, car control (right)	8	F-210-A	BOLT, NUT & LOCKWASHER, car wing	16
F-177	LINK, car control (long)	8	F-211	NOSE, car	8
F-178-A	LOCK RING, car control link	48	F-211-A	BOLT, car nose	16
RR-179	OUTLET BOX, lights	4	F-214	DOOR, car	8
F-179	BALL, car control link	48	F-215	BELT, car safety	8
F-180	SOCKET, car control link	96	F-225	SPINDLE, wing	16
F-181	WASHER, car control link	48	F-226	BEARING, wing spindle	16
F-182	SPRING, car control link	24	F-226-A	BOLT, wing spindle bearing	64
RR-182	COVER, light outlet box	4	F-227-L	WHEEL ASSEMBLY, car control (left)	8
RR-183	RECEPTACLE, light outlet	4	F-227-R	WHEEL ASSEMBLY, car control (right)	8
F-194	TAIL PIPE ASSEMBLY	8	F-228	TUBE, control spacer	8
F-194-A	CAP SCREW, tail pipe assembly	8	F-229	SEAT, car	8
0-193-A	CONNECTOR, light cable	3	F-230	BACK, car seat	8
0-198	CABLE, switch to ticket booth	1	0-317	CABLE, light (switch to cage)	1
F-198	CAR ASSEMBLY	8	RR-443	PIN, car door hinge	8
RR-208	KNOB, car door	8	RR-443-A	LOCK NUT, car door hinge	8
F-209	TAIL FLIPPER	16	RR-443-B	LOCKWASHER, car door hinge	8
F-209-A	BOLT, tail flipper	48	RR-445	BUSHING, car door hinge	16
RR-209	LATCH, car door	8			



FLY-O-PLANE PARTS CATALOG

FLUORESCENT LIGHT FIXTURE ASSEMBLY

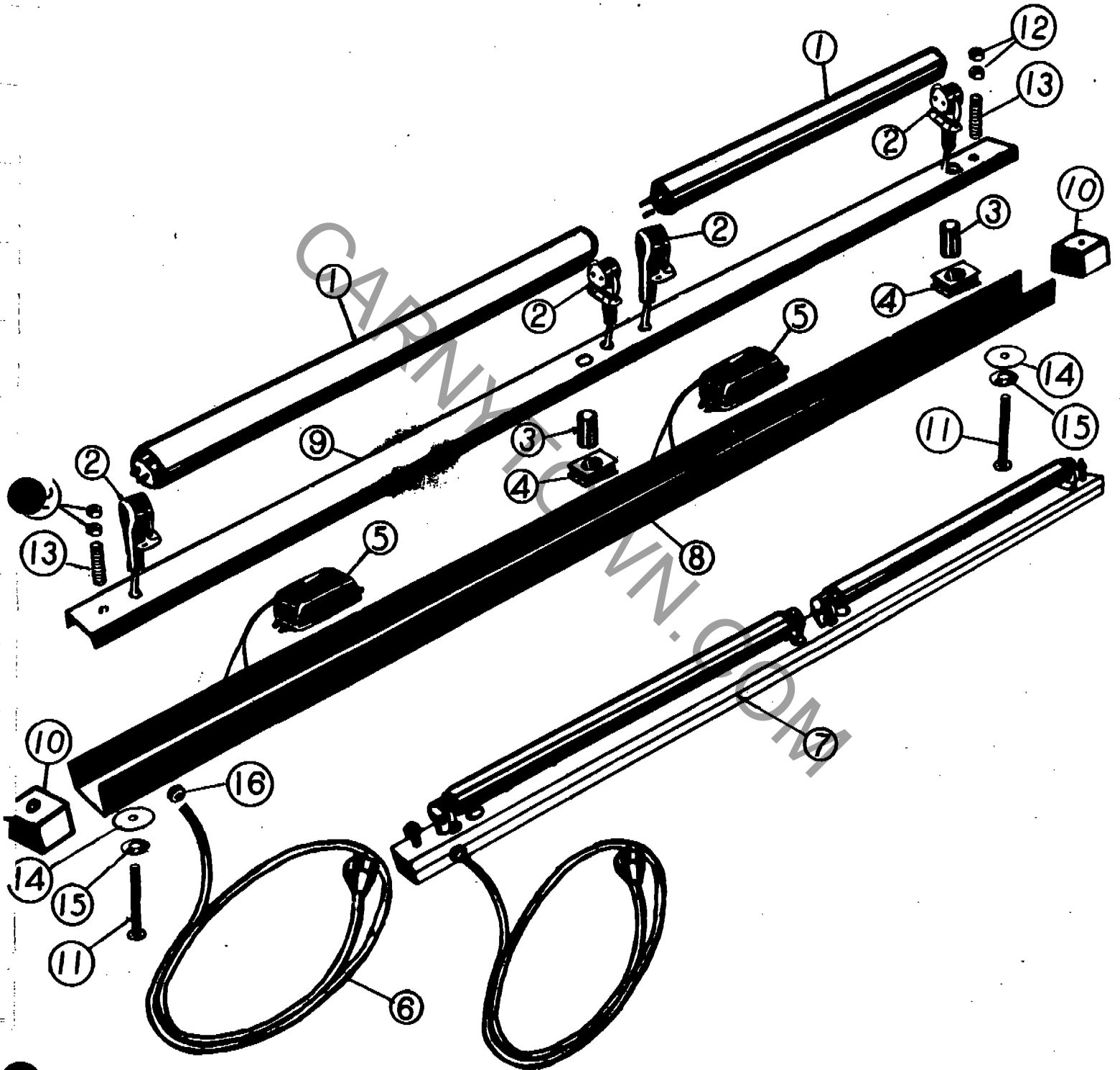



FLY-O-PLANE PARTS CATALOG

FLUORESCENT LIGHT FIXTURE ASSEMBLY

REF. NO.	PART NO.	NAME OF PART	NO. REQ.
1	MB-78	TUBE, Fluorescent	88
2	MB-79	SOCKET, Fluorescent tube	176
3	MB-80	STARTER, Fluorescent	88
4	MB-81	SOCKET, Fluorescent starter	88
5	MB-82	BALLAST, Fluorescent	88
6	F-303	CORD ASSEMBLY, Input, (upper outer fixture)	8
*	F-304	CORD ASSEMBLY, Input, (inner fixture)	8
*	F-305	CORD ASSEMBLY, Input, (intermediate fixture)	8
*	F-306	CORD ASSEMBLY, Input, (lower outer fixture)	8
*	F-307	CORD ASSEMBLY, Output, (inner fixture)	8
*	F-308	CORD ASSEMBLY, Output, (intermediate fixture)	16
7	F-309	FLUORESCENT FIXTURE ASSEMBLY, Upper outer	8
*	F-310	FLUORESCENT FIXTURE ASSEMBLY, Inner	8
*	F-311	FLUORESCENT FIXTURE ASSEMBLY, Intermediate	8
*	F-312	FLUORESCENT FIXTURE ASSEMBLY, Lower outer	8
8	O-482	BOX, Fluorescent, (upper outer)	8
9	O-483	COVER, Fluorescent box, (upper outer)	8
*	O-484	BOX, Fluorescent, (inner, intermediate & outer lower)	24
*	O-485	COVER, Fluorescent box, (inner, intermediate & outer lower)	24
10	O-486	BOX END, Fluorescent fixture	64
11	O-487	BOLT, Mounting	64
12	O-488	NUT, Mounting bolt	128
13	O-489	SPRING, Mounting	64
14	O-490	WASHER, Mounting bolt, (flat)	64
15	O-491	WASHER, Mounting bolt, (curved)	64
16	O-492	GROMMET, Cord	48
*		MACHINE SCREW, Tube socket & ballast, (6-32 X 3/8")	528
*		MACHINE SCREW, Starter socket, (6-32 X 3/4")	176
*		METAL SCREW, Cover, (No. 7 X 1/2")	112
*		WASHER, Ballast, (No. 10 flat)	176
*		LOCKWASHER, 6-32 machine screws, (No. 6)	704
*		NUT, 6-32	704

* not illustrated