

Jak-America
"Go Kart"
Non-Kiddie

INDOOR KART

JAK-AMERICA

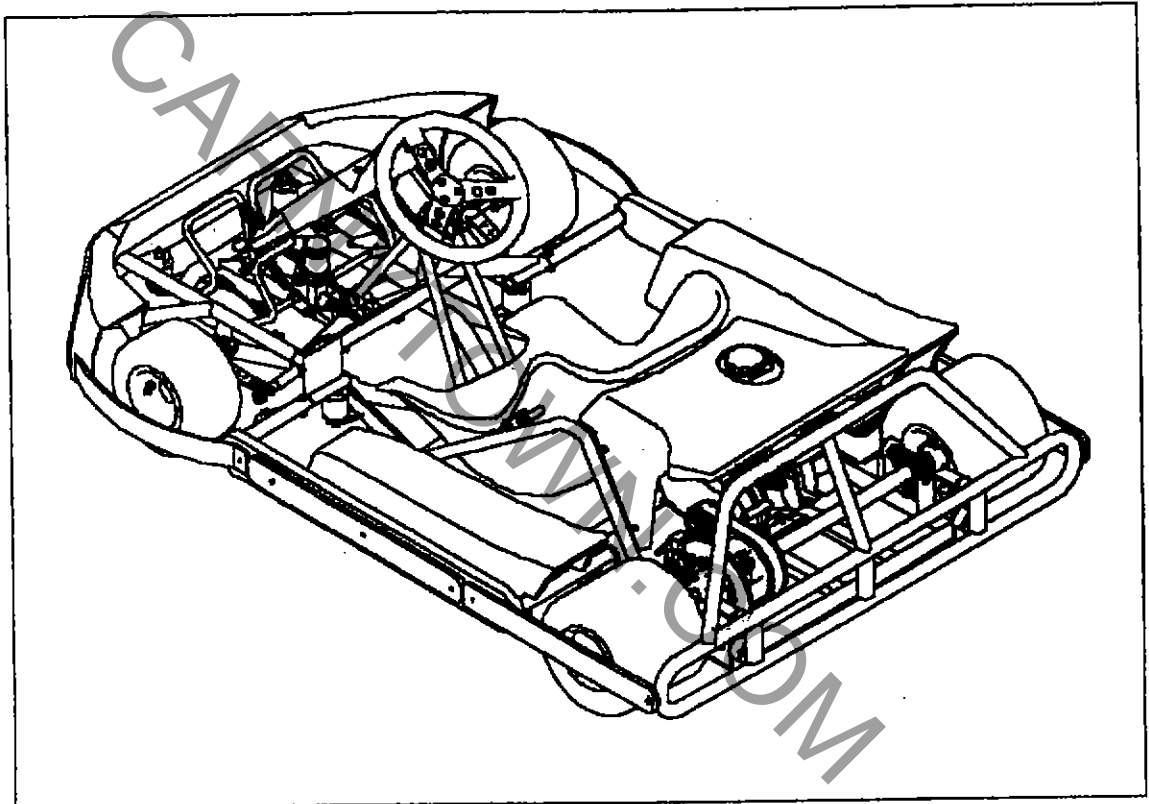

O P E R A T I O N - and S E R V I C E M A N U A L

D & M Ltd, 1997

IMPORTANT INSTRUCTION BEFORE OPERATING KARTS !!!!!!!!!!!!!!!!!!!!!!!!!!!!!

This Kart is not fully assembled at factory.



Following points must be completed:

1. Fill Motor Oil, Gear Oil and brake fluid.
2. Steering wheel and bumper must be monted.
3. All screws and bolts must be tighted.
4. Fill tire to rated air pressure.
5. Kart initial run to be tested at slow speed.
6. After initial test run recheck all bolts and screws.

For additional information call Distributor:

AMEXPO, Inc.

3979 NW 132nd Street
Suite M & N

MIAMI, OPA-LOCKA 33054, FL

Tel. 1-305-769-9332
Fax 1-305.769-9913

C O N T E N T S

0. SAFTY INFORMATION 3

1. DISCRIPTION 4

2. PREPORTATION 6

3. MAINTAINANCE and SERVICE 8

 3.1. TIRE PRESSURE 8

 3.2. WHEEL ALIGNMENT 8

 3.3. DRIVEBELT TENTION 8

 3.4. BRAKE SYSTEM 12

 §.5. GOVENER CONTROL 15

0. SAFTY-INFORMATION

*** JAK-KARTS are manufactured for safe and reliable operation if all procedures are followed.

*** Read entire Manual before operating Kart.

*** Before operating Kart, each time go through check - list on page 6, to avoid damage or accident with kart

*** Do not operate kart with in 3 feet of buildings or flamable materials.

*** Know where the engine shut off switch is located.

*** No one is to operate a Go-Kart without instruction.

*** Keep all flamables clear of running engines.

*** Fill gas tank in well ventalated area with engine off

*** Do not overfill tank

*** Make sure gas cap is tight.

*** Do not smoke or handle open fires near filling area.

*** Running engine exhaust carbonmonoxyd - do not inhale fumes. Do not operate in close area.

*** USE caution around hot metal pertsof engine. Let engine cool before storage kart.

1. DISCRIPTION

The Heart of this GO-KART is the high quality of the chassis - which is manufactured from solid precision pipe and the stable long life bumping frame stability.

In this connection of chassis and hitting frame, the manufacture took special care, that in case of collision the shocks are absorbed by special rubber-blocks.

Driver and Kart becomes the highest protection with this system. The special design of the chassis and covering of all movable parts, i.e. front and backwheels, give real protection against car bumping into each other, which would prevent Go-KARTS to jump.

The rubber-belt-drive eliminate the use of any petroleum/oil products for lubricant on the belt.

Additional safety are in the complet covering of the back axle and engine.

The disk brake system is full hydraulic and guarantee the highest protection in breaking system. This system is further protected from overheating, when the brake is being overused.

The stable steering system, the pedals and also the none-shock-sensitive pvc-tie-rods are developed for these "Safety Karts".

These are all unique specifications, that are added to provide safety for riders and karts:

*** High life stable chassis produce from 1 1/4 inch special pipe, protected against rust (corrosion) with special powder paint.

*** Special developed long-life bumping-frame with shock absorbant rubber, for shocking system - to protect driver and chassis. Scratch protection with special pvc-profiles.

*** Shock absorbant wheel protection with pvc profiles, preventing against the Go-Kart from jumping.

*** Standard rubber-belt-drive in high power edition incl. belt protection.

*** 1 inch back axle with high power bearing and stable chassis connection.

*** The disk braking system is self adjustend.

*** Shock absorbend tie-rod system is of special pvc.

- *** fullyhydraulic breaksystem and extra stable steering and brakesystem
- *** Tie - rod from special pvc
- *** Tires 7,1" and 4,5"
- *** Aluminum wheels
- *** Honda GX 160 engine
- *** Gasoline or propane

CARPENTRYTOWN.COM



IMPORTANT ADVISE-before operating JAK - KART

- 2.1. Fill up engine oil, gear oil, gasoline.
- 2.2. Fill up brake fluid. Bleed air from break system.
Check brake-pressure.
- 2.3. Assamble steering wheel and front cover (see 2.1.
picture).
- 2.4. Check tire-pressure (22,0 PSI front and 37.0 PSI back).
- 2.5. ***** Check every screw-connection.
- 2.6. Check/testdrive the kart at the track with slow speed.
- 2.7. After test drive - check every screw and bolt again.

PICTURE 2.1. STEERING WHEEL-and FRONT-COVER MONTAGE

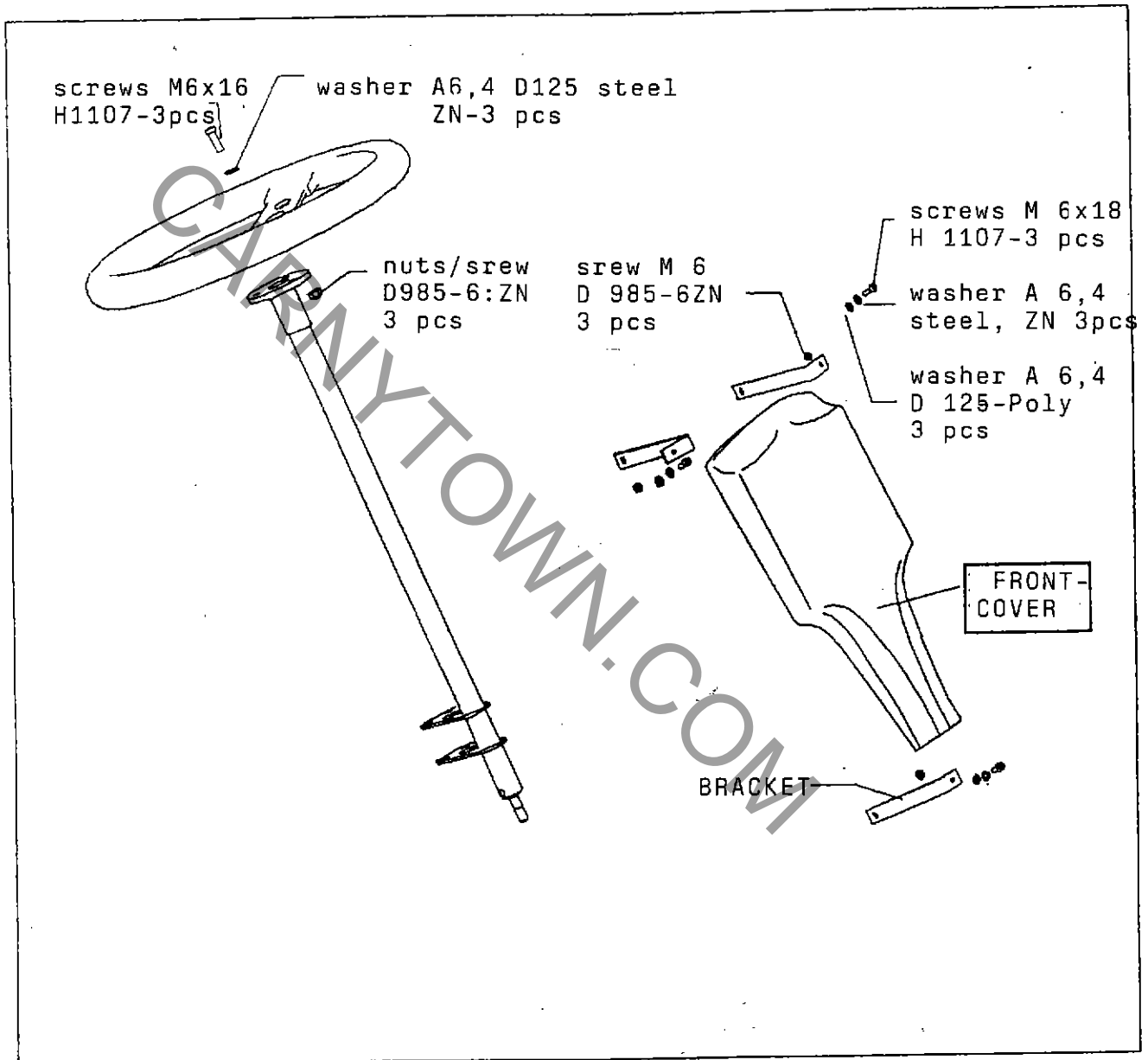

3. SERVICE

3.1. TIRE PRESSURE

Check daily.

Pressure has to be in front 22.0 PSI in rear 37.0 PSI.

3.2. ALIGNMENT

Check weekly the alignment and after changing tie-rod.

Adjust the alignment of the frontwheels as following:

1. Steering wheel in middle position.
2. Measure the distance between A + B.
(See illustration 3.1.)
The differenz between A+B has to be
 $A - B = 1/8 \text{ inch.}$
=====
3. If differenz is more, turn the tie-rod
2 (see illustration 3.1.) to correct the
difference. Before correction lose conter
screw.
4. Tie conter-srew again.

3.3. SERVICE BELT-DRIVE

3.3.1. Checking direction

Important - check daily !!! Engine has to be running !!!

- Lift Kart at the back
- Start engine and turn rear axle
- Check position of belt

Belt must be in the middle of ritzel (wheel) !!!

If not - regulate (see Ill. 3.3.3.) belt.

ILL. 3.1. ALIGNMENT and ADJUSTMENT:

=====

1-Conterscrew; 2-Tie rod

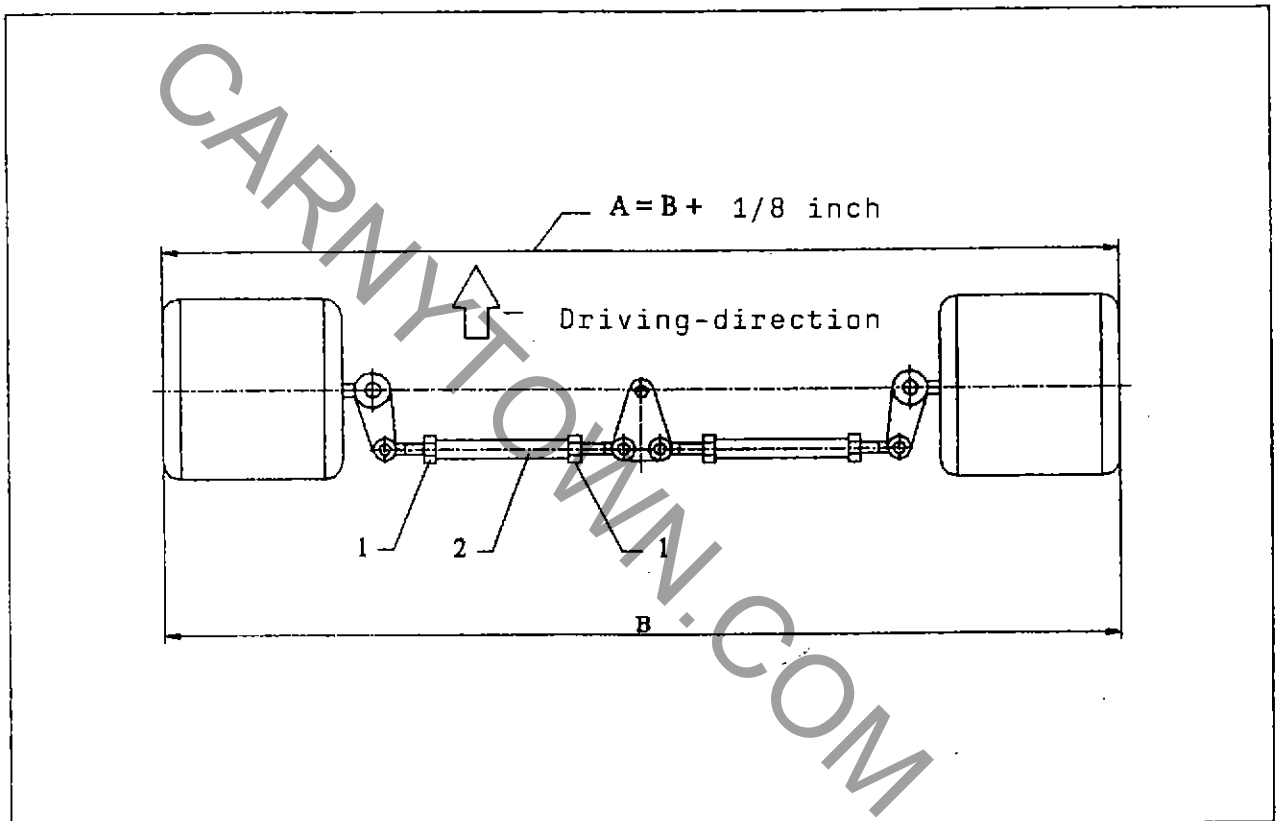

IMPORTANT !!!!!

The alignment must be adjusted to track conditions.
Testdrive on track for proper alignment !!!!
You can prolong the life of the tires with proper
alignment !!!

ILL. 3.2. ADJUSTMENT-SCREW and TIGHTEN DRIVE-BELT

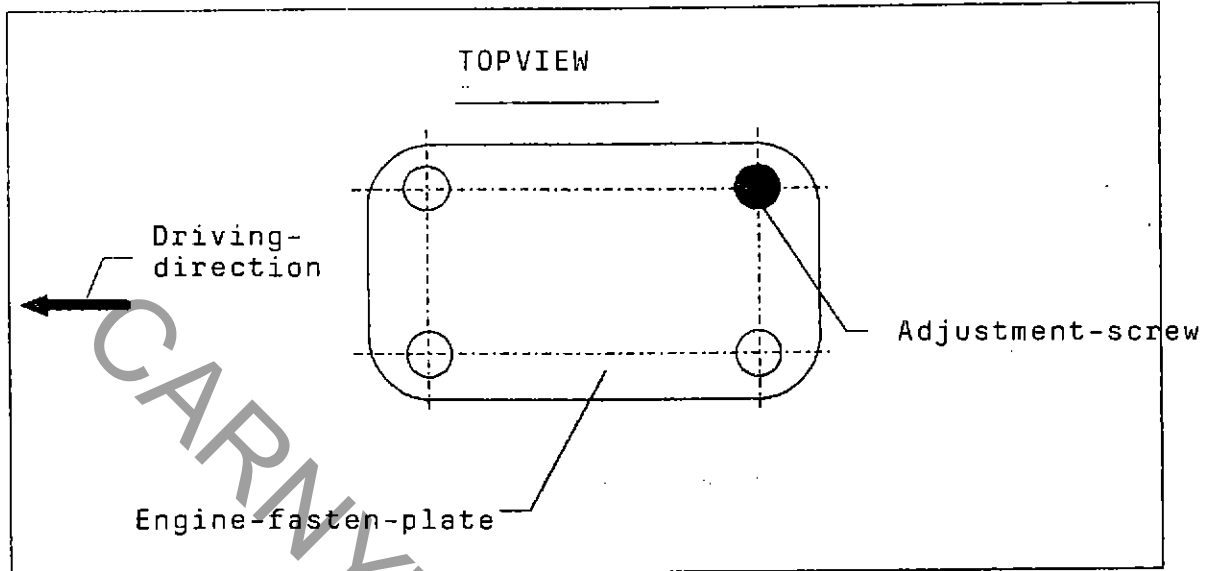

(a)

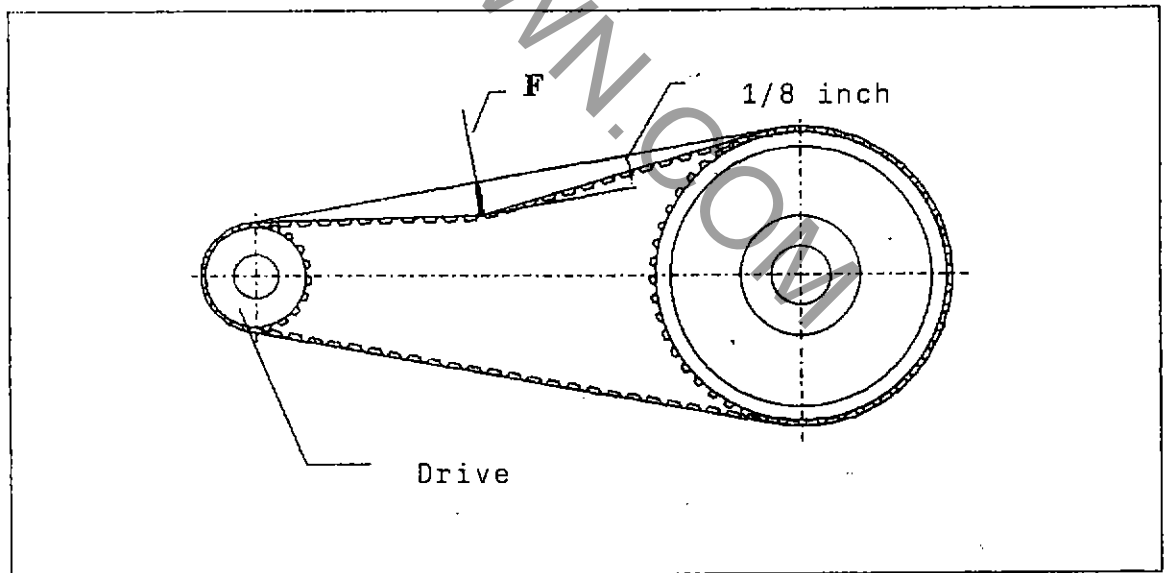

(b)

ILL. 3.3. FILL UP BRAKE FLUID and
BLEAD AIR OUT OF BRAKE SYSTEM:

1-Brake fluid container; 2-Bleeding (air) screw; 3-Hose; 4-Container; 5-Brakepedal

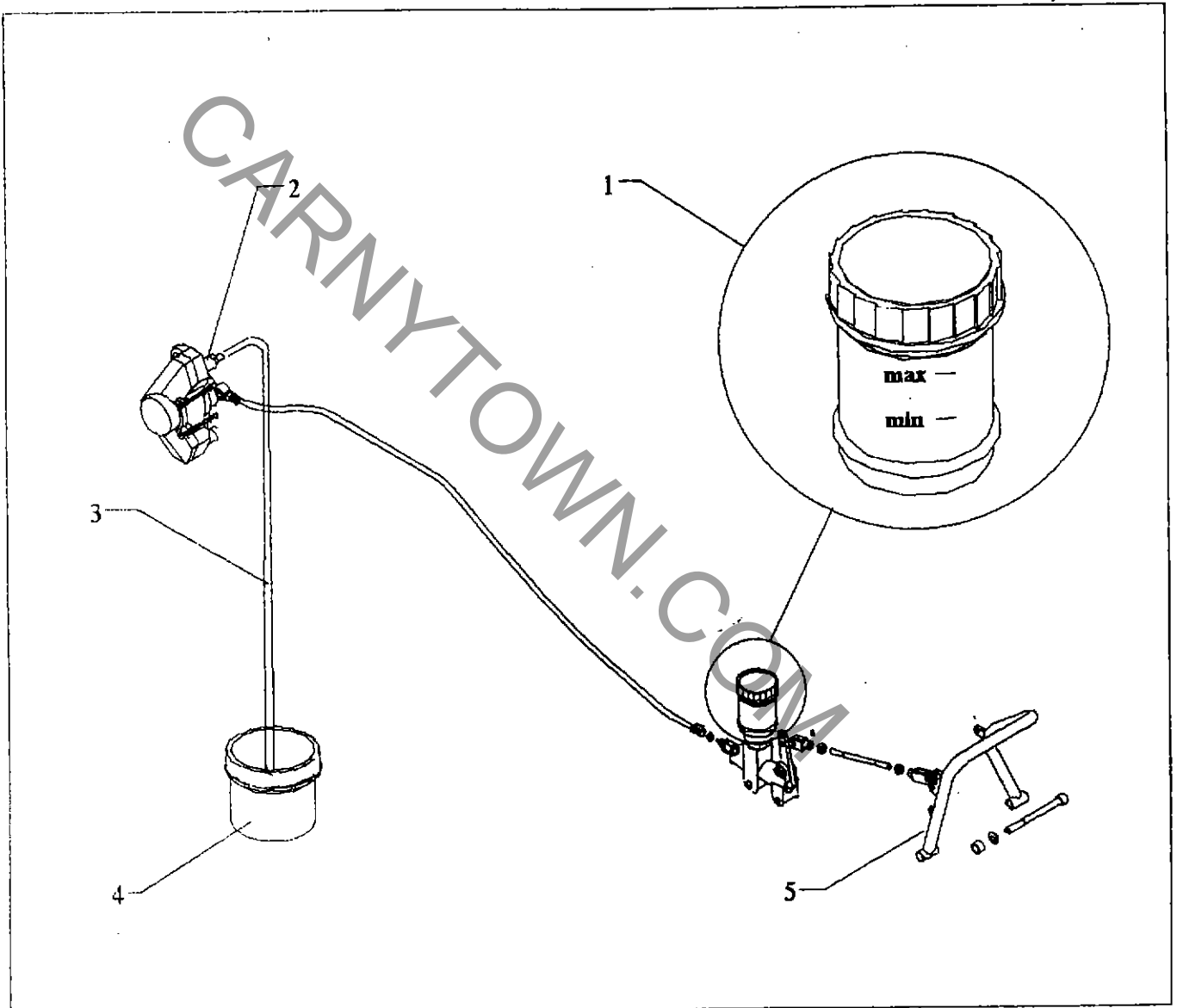

ILL. 3.4. CHANGING BRAKE LINING

1-Brake-pads; 2-Brake-shoe; 3-Splint/bolt

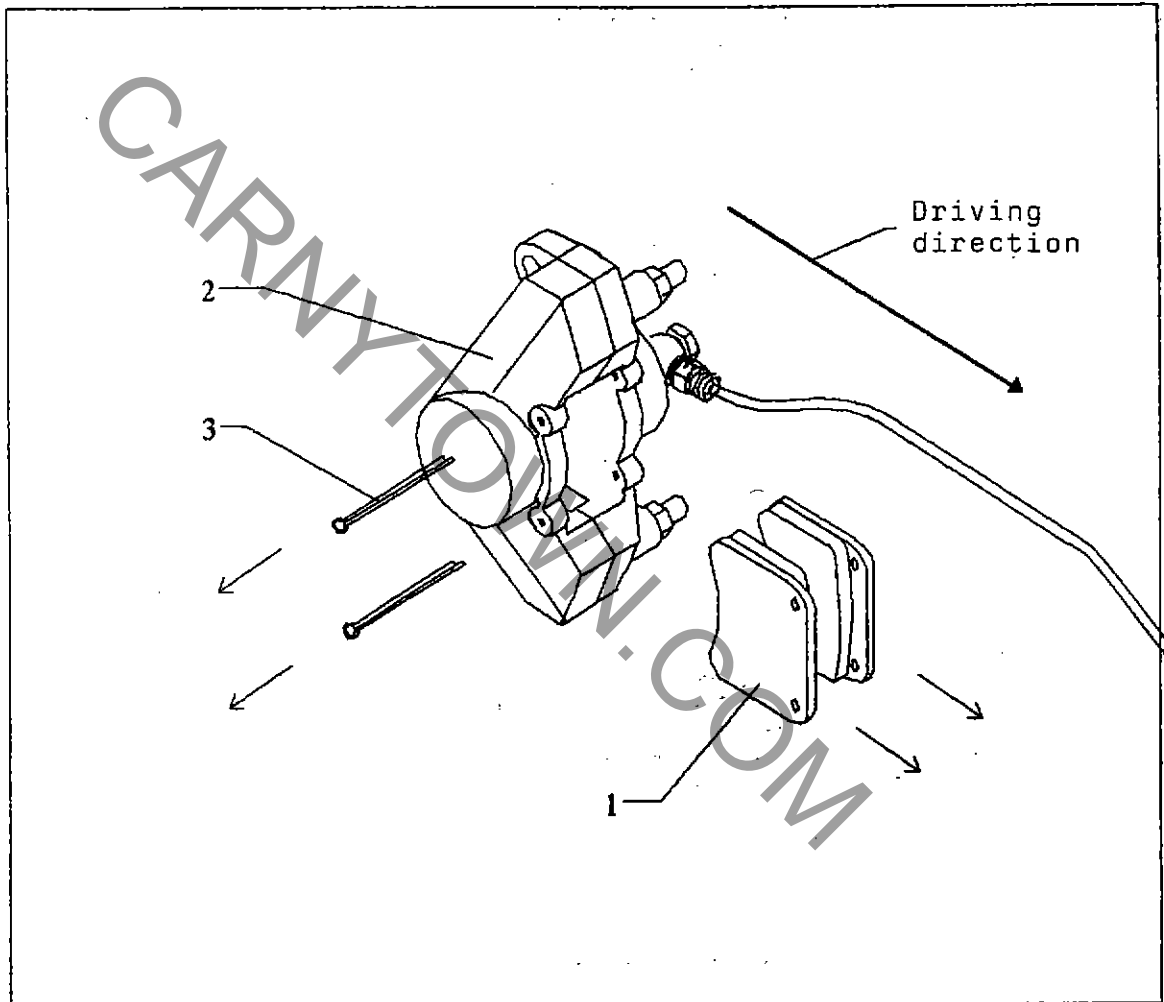

ILL. 3.5. ADJUSTMENT GOVENER CONTROL

1-Gaspedal; 2-Conterscrew; Adjustmentscrew

