



MASCHINENFABRIK

MFG: HUSS-HEINER, WILHIEM,  
CO.

NAME: FLIPPER

Type:

S E R V I C E L E T T E R F L - 0 1

Huss Maschinenfabrik GmbH & Co. KG - Postfach 110206, D-2800 Bremen

Stresemannstr. 56 · Telex 2 45 100 huss d  
☎ (04 21) 49 9000 · Telefax 4 99 00 40

REITHOFFER SHOWS  
Mr. Pat Reithoffer  
2520 N.E. 34 Court  
Lighthouse Point, FL 33064

**RETURN RECEIPT  
REQUESTED**

Unsere Zeichnung/Inhalt

Unser Zeichen  
Dr/Mi

Telefon-Durchwahl / Kommission / Ing  
Bremen, October 25, 1990

RE: Flipper #53352

Measurements of the hydraulic outflow of the center drive circuit show the need to limit the oil quantity, which has no effect on the operation.

PROCEDURE:

Unscrew the orifice valve using a #14 hexagon (see arrow on enclosed picture)

The enclosed 1.8mm screen has to be placed according to the enclosed picture, and should be pressed (using light force) into the valve. Do this by placing the valve upright on a firm base. Afterward, screw the valve back into the block with 30-35 Nm torque.

If you have any questions, please contact our service department.

HUSS MASCHINENFABRIK  
GmbH & CO. KG.

Enclosed: 2 pictures  
1 (1.8mm) screen



MASCHINENFABRIK

Huss Maschinenfabrik GmbH & Co. KG - Postfach 110206, D-2000 Bremen

Stresemannstr. 56 - Telex 245180 huss d  
☎ (04 21) 499000 - Telefax 4990040

REITHOFFER SHOWS  
Mr. Pat Reithoffer  
2520 N.E. 34 Court  
Lighthouse Point, FL 33064

**RETURN RECEIPT  
REQUESTED**

Ihre Zeichen/Nachricht

Unser Zeichen

Telefon-Durchwahl / Kommission / Tag  
Bremen December 21, 1990

SERVICE LETTER FL-02

RE: Flipper #53352 - Gondola

Under certain circumstances it is possible that a break-away draw spring of the gondola locking device could be thrown in the cracks between the gondola frame and the fiberglass.

If the above happens during operation, it is possible the the spring could be thrown into the audience.

To avoid this from happening, please install the enclosed flat steel Pos. #80 and #81 on the fiberglass connected by the bolts #58. Use Loctite to secure the bolts.

HUSS MASCHINENFABRIK  
GmbH & CO. KG.

Enclosure: Drawing 1-19.2.B1.3  
(24) flat steel bars

Rechtsform: Kommanditgesellschaft, Sitz Bremen, Registergericht Bremen HRA 18316  
Persönlich haftende Gesellschafterin: Huss Maschinenfabrik GmbH,  
Sitz Bremen, Registergericht Bremen HRA 10337  
Geschäftsführer: Dieter Welschewick, Hans-Karl von Winterfeld

Bremer Bank : (DLZ 290 800 10) Kto.-Nr. 211 391 000  
Bankhaus Neelmeyer AG : (DLZ 290 200 001) Kto.-Nr. 8500  
Postplacemat : Hannover (DLZ 250 100 301) Kto.-Nr. 1504 84-300



MASCHINENFABRIK

Huss Maschinenfabrik GmbH & Co. KG - Postfach 110206, D-2800 Bremen

Stresemannstr. 56 - Telex 245180 huss d  
(04 21) 49 90 00 - Telefax 4 99 00 40

Ihre Zeichen/Nachricht

Unser Zeichen  
Dreier/rö.

Telefon-Durchwahl / Kommission / Tag

07.05.1992  
(May 5, 1992)

S e r v i c e L e t t e r N o . 0 3

Re.: FLIPPER GONDOLA FRAME 53 352

Dear customer,

cracks in the lower main frame on the entrance and exit area have been discovered on a few Flipper rides.

According to drawing 2-24 248, disconnect the floor plates and inspect the areas 1-3 and 2-4. If you discover cracks, they must be welded immediately (by a certified welder only). The inspection of these areas should continue in the future. The beam with cracks should also be reinforced with brackets/plate according to the enclosed drawing.

We also want to direct your attention again to the paragraph "Responsibility of Managers & Operators" in your manual.

Regards

Huss Maschinenfabrik  
GmbH & Co. KG

Encl.  
drawing No. 2-24 248

Rechtsform: Kommanditgesellschaft, Sitz Bremen, Registergericht Bremen HRA 19316  
Persönlich haftende Gesellschafterin: Huss Maschinenfabrik GmbH,  
Sitz Bremen, Registergericht Bremen HRB 10337  
Geschäftsführer: Dieter Weinschenck, Hans-Karl von Winterfeld

Bremer Bank : (BLZ 290 800 10) Kto.-Nr. 211 391 000  
Bankhaus Neelmeyer AG : (BLZ 290 200 00) Kto.-Nr. 6500  
Postgiroamt : Hannover (BLZ 250 100 30) Kto.-Nr. 1584 84-300

3 12 Stück  
wie gez.

0,7Kg/Stück

4 12 Stück  
spiegelbildlich

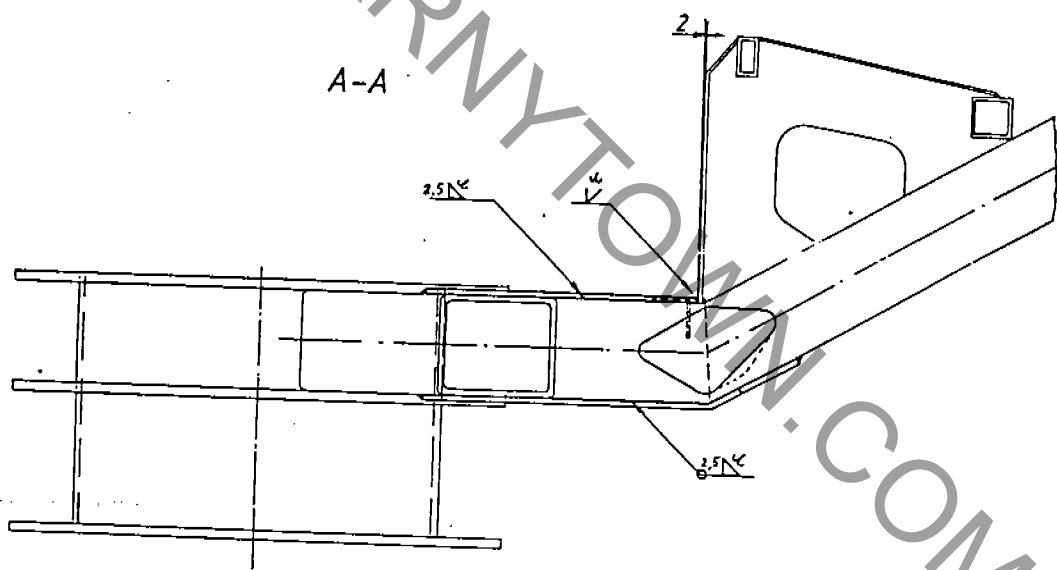
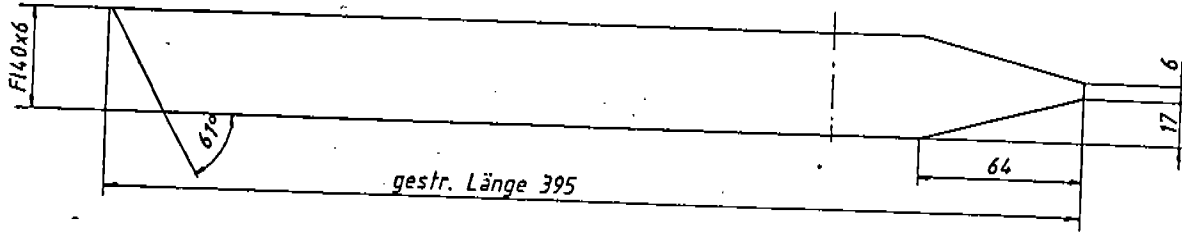
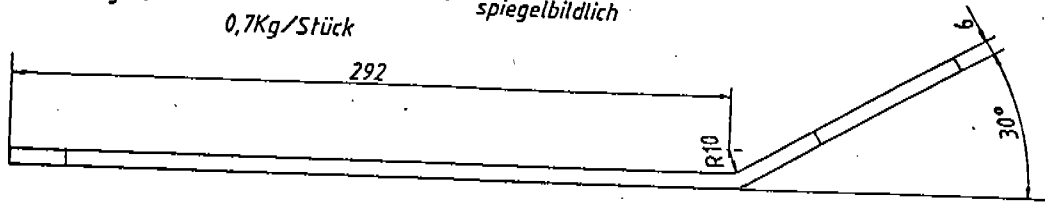

Fremdfabrikation: 1. Allgemein, DIN 718 Blatt 1 (mitteil) 2. Brunnenfedern, DIN 2210, Tabelle 3/10 und 2/18 3. Schweißbohrmaschinen, DIN 6570 Blatt 1 (BL 3 P)	Urheberrechtsvermerk nach DIN 34 beachten		Maßstab 1:10/1:5/1:2	Gewicht 28,8Kg	
			Werkstoff RSt37-2	Type Projekt 19	
	Bearb. 4.3.92	Datum	Name HUL	Sanierung am Gondelgerüst	
	Gepr.	Norm			
ZIESS Huss Maschinenfabrik GmbH & Co. KG D-72616 Heilbronn					
			Zeichnung Nr.	2-24248	

1 12 Stück  
wie gez.

0,5Kg/Stück

2 12 Stück  
spiegelbildlich

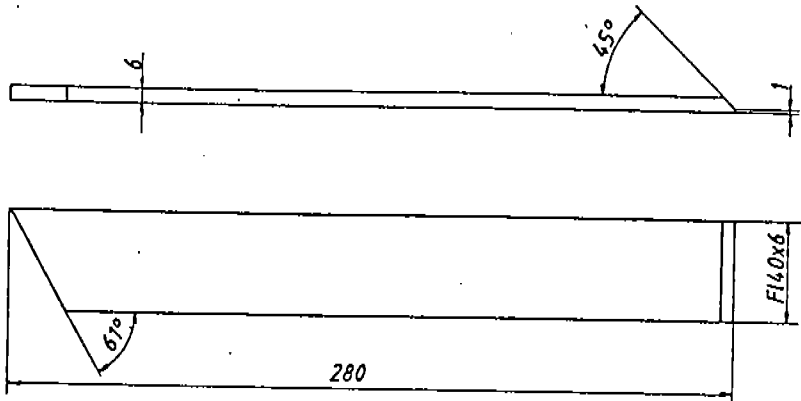

CARNYTONLINE.COM

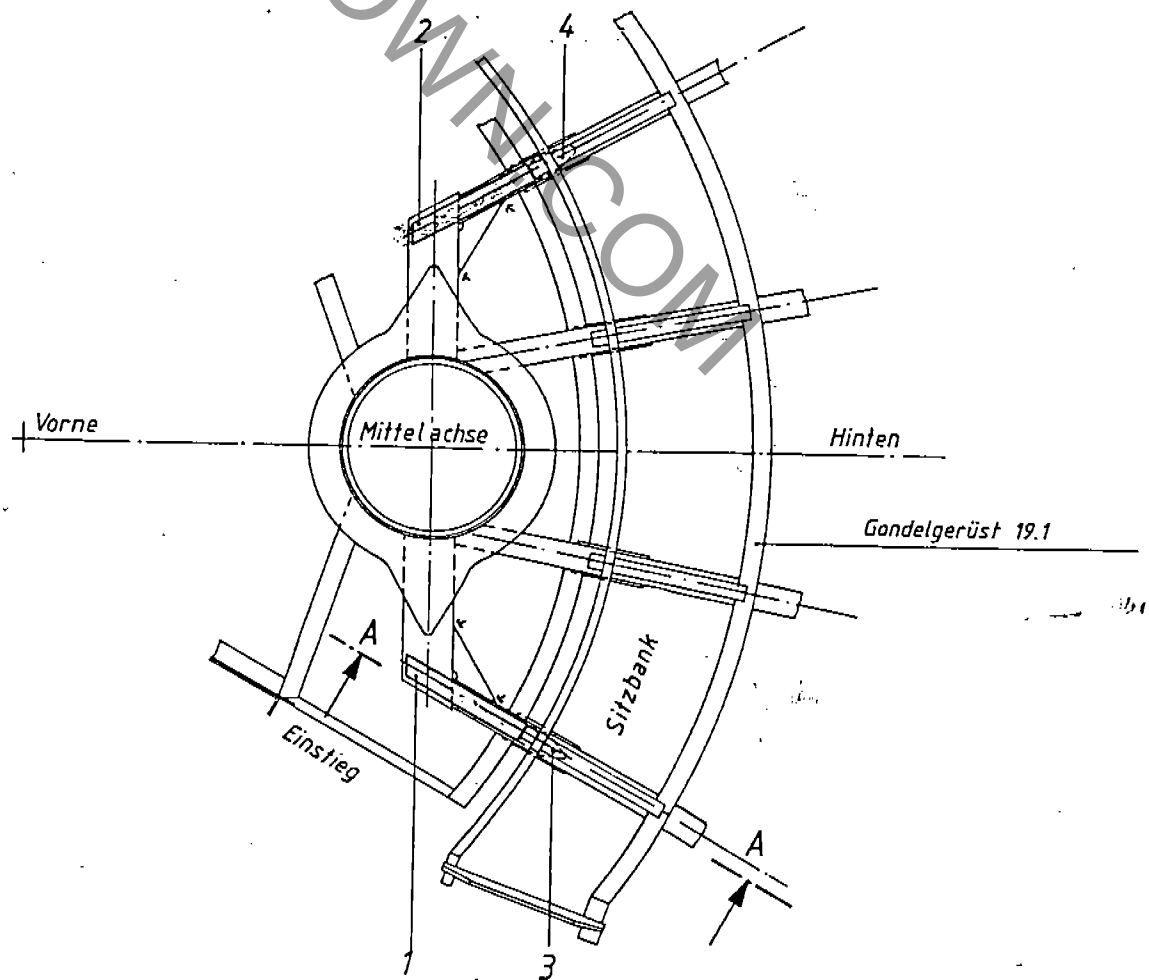



MASCHINENFABRIK

OPERATING INSTRUCTIONS

for

Carrousel "FLIPPER"

I.	General References	pages 1 - 3
	1. Handing Over Confirmation	
	2. Responsibility of Managers and Operators	
	3. Contents	
II.	Erection and Dismantling	pages 4 - 8
III.	Regulations for Daily Operation	page 9
IV.	Lubrication and Maintenance	pages 10 - 13
	A) Electric Motors	
	B) Hydraulic System	
	C) Compressors	
	D) Live Ring	
	E) Bearing of Swivelling and Lifting Cylinder	
	F) Gondola Bearing	
	G) Erection Hydraulics	
	H) Tyres for Trailers in case of Road Models	
V.	Safety Regulations for Carrousel "FLIPPER"	pages 14 - 16
VI.	Maintenance Instructions for Fiberglass Surfaces	page 17
VII.	Drawings	
	No.: 1-19.00	Carrousel "FLIPPER" page 18
	1-19.B.0.1 Bl. 1 + 2	Wheel Disk pages 19/20
	A 1-19.D	Platform page 21
	1-19.E.O	Backdrop page 22
	1-19.22	Support Blocks page 23
	1-19.24.O	Frame for Centering
		Flooring page 24
	A 1-19.42.0	Transport Scaffolds page 25
	2-19.17.C	Hydraulic Scheme page 26
	4-19.35.A	Hydraulic Scheme
		(erection) page 27
	A 3-19.33.A	Pneumatic Scheme page 28
VIII.	Instructions of the Manufacturers	
	Operating Instructions Linde Company	page 29
	Operating Instructions Bucher Company	page 30
	Operating Instructions Mahle Company	page 31
	Operating Instructions Leroy-Sommer Company	page 32
IX.	Electrical System Plans	pages 33 - 55



MASCHINENFABRIK

RESPONSIBILITY OF MANAGERS AND OPERATORS

The following remarks are a compulsory condition for the safe operation of the ride:

1. In all cases the manager is ultimately responsible for the safety of passengers during operation of the ride.
2. Selection of operators must correspond to the demands made on them regarding operation of the ride.
3. The operator must devote his undivided attention to the operation of the ride.
4. He must be acquainted with the functioning of the ride, its safety devices, emergency devices, operating instructions and regulations, and ensure the safety of passengers and safe running of the ride.
5. He must have complete and safe control over the unloaded ride before he operates it with passengers.
6. If a malfunctioning occurs operation must cease immediately.
7. Malfunctioning may often be detected by a change in noise during operation. If this occurs, one should look for the cause and, if necessary, get in touch with experts to find the reason for any malfunctioning.
8. The operator must insist on maintenance work being carried out, as it is described in detail in the operating instructions. If he does not, he is obliged to cease operation.
9. Before initiation the operator has to check the ride on its perfect working condition by performing the ordered controls and the trial runs.
10. The carrying parts as well as the motor driven parts are to be checked on perfect working condition before each initiation. Damaged parts are to be substituted by perfect ones. Furthermore it has to be observed that the ride is in safe upright position during erection and dismantling. After erection all parts have to be orderly connected and all connecting parts and necessary anchorages have to be mounted in a safe way.
11. The complete operating instructions provided by the manufacturer have to be kept at hand in the operator's stand so that the operator can have a look at them at any time.

Upon loss, the manufacturer has to be immediately requested to provide a new copy of the complete operating instructions.



MASCHINENFABRIK

## II. ERECTION AND DISMANTLING

### Central Section

1.) The central section (1) has to be moved to the planned central point in such a manner that the front axle is within the area of the entry.

2.) Fix rear axle by means of wheel chocks.

3.)

#### I M P O R T A N T !

The seven booms in the transport frame (13) must be lifted off the center structure either individually or all together in one bundle before the front axle or the semitrailer is run out.

However, it is essential for the three transport support frames (2), Drawing No. 1-19.42.0 to remain on the base structure!!

- 4.) Provide the two front hydraulic cylinders (3) with stable underlays (4). Lift the base structure evenly until the front undercarriage is only just still touching the ground. Using cranks, unscrew the locknuts on the front section of the base structure and pull out the two bolts. Run the undercarriage away from the ride. Remove the turnbuckle tie rods.
- 5.) Swing out stabilizers (5) and bolt bracing struts (6).
- 6.) Lay out the front support blocks (7) in exact accordance with the dimensions of the ride and set up the two erection aid supporting devices (8) provided to facilitate erection of the ride.
- 7.) With the aid of the two front hydraulic cylinders (3), lower the center structure until the front stabilizers (5) come to rest on the two erection aid devices (8).
- 8.) Lay out the two rear support boards (9) and the underlay (10) for the rear aligning cylinder (11) in exact accordance with the dimensions of the ride.
- 9.) Swing out rear stabilizers (12) and bolt bracing struts.
- 10.) Align central section so that the tilting arm (14) is horizontal.
- 11.) The erection aid wedges (15) must be tightly fitted between the support boards (9) and the stabilizers (12).



MASCHINENFABRIK

---

I M P O R T A N T !

The tilting arm with the rotating structure must be exactly horizontal prior to removal of the three transport support frames (2) as otherwise the booms will swing out on their own.

D A N G E R   O F   A C C I D E N T S !

---

Wheel

- 12.) Remove the transport support frames (2).
- 13.) The wheel can be turned by hand to facilitate assembly. For this, open the hand valve (16) located at the end of the tilting arm.
- 14.) Fit the boom (17) with the HUSS nameplate together with the 2 fixed turnbuckle tie rods, Item (19), so that the longitudinal axes are exactly aligned.
- 15a.) Fit the struts of the inner ring (7.3).
- b.) Fit the struts of the middle ring (7.2) and only use the diagonal turnbuckle tie rods, Item (7.5) to facilitate insertion of the pins where this is necessary. After inserting the pins, slacken off the turnbuckle tie rods, Item (7.5) again!
- c.) Fit the struts of the outer ring, Item (7.1).
- 16a.) Now screw the bracing stays diagonally opposite to Item (19), namely those of Item (7.4) as tightly as possible by hand and secure against loosening with locknuts.
- b.) Screw the 4 remaining bracing stays of Item (7.4) as tightly as possible by hand and secure against loosening with locknuts.
- c.) Tighten the turnbuckle tie rods, Item (7.12) as far as possible by hand and secure against loosening with locknuts, so that one end of the pins, Item (7.15.2) rests in the holes.
- d.) Finally tighten all diagonal turnbuckle tie rods, Item (7.5) as far as possible by hand and secure against loosening with locknuts.



MASCHINENFABRIK

---

I M P O R T A N T :

When assembling the wheel in accordance with Drawing No. 1-19.B.0 Sheets 1 + 2, it is essential to adhere strictly to the above sequence as otherwise distortions in the structure may give rise to additional stresses and drilled holes could become widened prematurely as a result.

---

17.) Connect up all electrical connections and compressed air lines.

Gondolas:

18.) Place the gondolas (20) on their mounts on the booms and carefully bolt in position with 4 bolts M 20 x 60, DIN 6914-10.9 with washers and nuts.

---

~~Lightening torque for gondola mounting bolts = 430 Nm~~

---

19.) Connect the light plugs.

Wheel flooring

20.) Fit the outer ring of the wheel flooring as per Drawing No. 1-19.B.0 Sheets 1 + 2, bolt and secure.

Center structure

21.) Remove the two erection aid devices (8) and the erection aid wedge (15).

22.) Close the hand valve (16) again.

23.) With the aid of the hydraulic cylinders (3), lower the front part of the center structure. Prior to this, first lay support boards (7) furnished with a wooden overlay under the front stabilizers (5) in exact accordance with the dimensions of the ride.

24.) Lay support boards (9) with the now erected support trestles (21) furnished with a wooden overlay under the rear stabilizers (12).

25.) Using the erection hydraulics, lower the bottom edge of the center structure to a position 20 mm over the highest point in the terrain



MASCHINENFABRIK

as per Drawing No. 1-19.22. The two following points are now available for exact horizontal alignment of the ride.

- 1) Laterally: On the tilting arm over the tilting arm axis
- 2) Longitudinally: On the center structure on the wedge provided (24)

---

I M P O R T A N T !

Wooden boards must always be in position between the support boards (7) and the front stabilizers and between the support trestles (21) and the rear stabilizers (12)!

---

Floor centering frame

- 26.) The first step is to fix the two frames (22) onto the base structure, see Drawing No. 1-19.24.0.
- 27.) Then connect the other struts (23) and align horizontally! Insert the crossbeams.  
Secure all pins with spring locking pins.

Platform

- 28.) Start assembly of the platform at the front on the center structure as per Drawing No. 1-19.D.
29. Initially assemble all frames with the inner crossbeams only and at the same time underpin with support blocks.
- 30.) When the inner ring of crossbeams is closed, fit the remaining components.
- 31.) Insert the turnbuckle tie rods, tighten the turnbuckles as far as possible by hand and secure against loosening with locknuts.
- 32.) Fit the flooring plates, panels, railing posts and railings.

Rear Wall (Backdrop)

- 33.) Bolt the rear wall uprights onto the flooring frame as per Drawing No. 1-19.E.0 and in each case fit the cross-connections with the cross-over turnbuckle tie rod arrangement. Insert the plates of the facade catwalk.
- 34.) Fit the lettering support frames to the middle rear wall uprights.



MASCHINENFABRIK

- 35.) Hook on the lettering panels. Fit the lettering and decorations.

Wheel

- 36.) Fasten the decorations onto the booms.
- 37.) Fit the inner wheel flooring and the railing barriers, bolt into position and secure with spring locking pins as per Drawing No. 1-19.B Sheet 2, Section A - A.

Control Stand

- 38.) Center the base structure of the control stand on the front platform and securely underpin with support blocks.
- 39.) Place the control stand on its supporting frame.

Dismantling is exactly the same procedure in reverse order.

In this case, it is especially important to make sure that all electrical cables and compressed air connections are disconnected in good time !!

---

All plugs and sockets must be protected against dirt, dust and other contaminants!

Keep all sockets covered over !!

---



MASCHINENFABRIK

III. REGULATIONS FOR DAILY OPERATION

Putting into operation:

1. Check that all M 20 gondola mounting bolts are firmly seated and screwed tight.
2. Check that all bolts are properly secured by spring locking pins.
3. Check that all safety signs are put up in such a way that they can be easily read.
4. When establishing the electrical connections, check for correct phase sequence on the main three-phase current motor! Watch the indicator lamps.
5. Check the hydraulic oil level in the main reservoir and add oil, if necessary.
6. Check the oil levels on the two compressors.
7. Grease the teeth of the ball-bearing slewing gear (30) (see IV.D).
8. After approx. 30 hours of operation, inject ball-bearing grease into the lubricating nipples of the ball-bearing slewing gear (see IV.D).
9. Run the hydraulic aggregate at no-load for approx. 10 minutes. In cold weather, the ride must be run at no-load for approx. 1 hour to reach the right oil viscosity.
10. Run at least 3 complete ride sequences with unoccupied gondolas using all control facilities and possibilities and at the same time check the support blocks.
11. After the trial runs have been successfully completed, commercial operation of the ride can be started.
12. All safety locking bars must be closed at all times during the ride sequence. The wheel must not be accelerated beyond creeping speed until all persons standing on the wheel have left it and are standing behind the red markings on the outer flooring ring!

Shutting down:

1. Run the wheel with the gondolas to the proper embarkation/disembarkation position.
2. Switch off the hydraulics in the control panel and lock the control panel.
3. Switch off the main power switch in the switchgear cabinet and lock the cabinet.



MASCHINENFABRIK  
IV. MAINTENANCE AND LUBRICATION

A) 90 kW electric motor

If any dust accumulates, the motor must be blown through with dry air at reasonable intervals and any deposits inside the motor or in the ventilation openings must be removed. The two lubricating nipples (31) must be kept clean. Lubricate periodically after 1500 hours of operation using ESSO multi-purpose grease "BEACON 2".

B) Hydraulic system

The most important precondition for perfect and reliable operation is a clean hydraulic system.

Dirt in the hydraulics results in a faster fall-off in pump performance and shortens the service life of all parts. Dirt can also block important control functions.

The whole hydraulic system contains approx. 1.000 liters of hydraulic oil ESSO NUTO H 68 (SAE 20). First check the oil quantity after 50 hours of operation. If necessary exchange the oil. Further oil changes every 1500 hours of operation.

New oil must always be filled into the oil tank via a clean filter with a filter grade of at least 40 my.

Check the return flow filter (32) for clogging after the first 2 weeks of operation and clean if necessary; repeat at reasonable intervals.

Clean the magnetic needle (33) in the return flow filter daily during the first 2 weeks; thereafter repeat at reasonable intervals.

B1) Pump for rotation drive aggregate

Hydraulic variable displacement pump from Linde company, Type PV 186.

The built-in MANN exchangeable oil filter must be exchanged for the first time after 50 hours of operation, then yearly and on each oil change.

B2) Pump for tilting drive aggregate

High-pressure gear pump from the Bucher company, Type QT 83-250.

B3) Rotation drive

Hydraulic motor from the Poclain company, Type H25-3122 cm<sup>3</sup>/rev, directly connected to the drive pinion.

When the hydraulic oil is changed, the chamber of the Poclain motor is not filled with oil. This chamber must be filled via the oil filter pipe (34) on the Poclain motor. The oil vent screw (35) must be open during the filling process!



MASCHINENFABRIK

B4) Hydraulic lifting cylinder

The lifting cylinder has a built-in hose-break safety device. Following long periods of disuse, air may collect in the upper part of the cylinder and this must then be expelled via the mini measuring pipe (36), since air in the cylinder makes for an uneven or jerky lifting movement. The packings on the cylinder must be exchanged when oil leakage exceeds 1/4 liter per day.

B5) Hoses

All hoses are marked with position code numbers which must be stated without fail when ordering spares.

According to the manufacturers, the hoses should be renewed after every 4.000 hours of operation.

Hydraulic hose Item 19.17.55 must be exchanged without fail after 4.000 hours of operation. When exchanging pressure hoses or re-connecting a disconnected hose, make sure that the hose is properly positioned (any bends must be in one plane only)!

B6) Diaphragm accumulator

This must be exchanged after approx. 1.000 hours of operation.

C) Compressors

The oil level must always lie within the red ring. Overfilling can also cause problems. First oil change after 50 hours of operation, thereafter every 500 hours of operation but at the latest every 12 months. Use only HD engine oils SAE 30 which correspond to the VC-L group as per DIN 51 506.

At reasonable intervals, the suction intake filter must be washed with a washing agent and then oiled.

Occasionally vent the safety valves by hand to prevent the valve seatings from sticking.

Once a week, open the condensate drain valves on the tanks and run the condensate off under pressure.

Regularly check the condensate in the transparent reservoir of the filter pressure reducer. It must never exceed the upper mark or flood the baffle plate. Drain the condensate by pressurising the drain valve.

Now and again clean the cooling fins of the compressor and the motor. Good cooling is important for problem-free operation.

D) Live ring

The toothing of the live ring must be greased either daily or at the latest as soon as bare patches are seen on the gear teeth, using gear grease MOLYKOTE 165 BR or Calypsol heavy-duty gear spray from



MASCHINENFABRIK

UK-Mineralölwerke Wenzel & Weidmann, D-5180 Eschweiler. The ball-bearing mounted tracks of the live ring must be greased daily or at the latest after 30 hours of operation using ESSO Multi-Purpose Grease "BEACON 2". Greasing nipples are provided for this purpose. Turn the bearings while applying the grease, i.e. push button for advancing.

Check the M 20 fixing bolts on the live ring at regular intervals for tightness using the torque wrench supplied with the ride. First undo the individual bolts and then retighten with 580 Nm for M 20.

E) Tilting arm and lifting cylinder bearing

The axle of the tilting arm is mounted in maintenance-free tilting bearings. The tilting bearings of the hydraulic lifting cylinder are also maintenance-free. If any noise is heard coming from a bearing during the tilting process, check the coating; if any slight destruction is detected, the ride can still be run for max. 1 week with this bearing if amply greased, but then the tilting bearings must be renewed.

F) Gondola bearings

The gondola bearings are fitted with self-aligning roller bearings. These must be greased after approx. 4.000 hours of operation or when they start to make noises. Overgreasing may result in the bottom radial packing ring being forced out of position.

Once a year, the carbon dust must be removed from the slipping assembly above the bearing point. For this, first remove the hood (37).

G) Erection hydraulics

The hydraulic aggregate with the oil reservoir is located in the subframe. The whole hydraulic system contains approx. 50 liters of hydraulic oil ESSO NUTO H 68 (SAE 20).

The most important precondition for perfect and reliable operation is a clean hydraulic system.

Dirt in the hydraulic system results in a faster fall-off in pump performance and shortens the service life of all parts. Dirt can also block control functions.

Always make sure that the system has enough oil (up to the centre of the oil sight glass). Following long periods of disuse (max. 2 months) and after each oil change, any bubbles which may have entered the system must be carefully eliminated. For this purpose, venting facilities are provided at different locations.

H) Trailer tires on roadmodels

Tires: 8.25 x 15 x PR 18  
Air pressure: 9 bar at 80 km/h



MASCHINENFABRIK

I M P O R T A N T !

To fulfil the guarantee conditions, only original  
HUSS spare parts may be used!

Always state the serial number when ordering spares.

This is to be found on the manufacturer's nameplate  
on one of the booms.

Attention !

If you want to operate the ride at temperatures below the  
freezing point of water, please contact HUSS with regard to the  
air pressure system.

CARNY TOWN.COM



MASCHINENFABRIK

V. SAFETY REGULATIONS

for Carrousel

"FLIPPER"

1. The ride must be erected so that a sufficient distance is maintained away from houses, trees, electrical cables etc. (min. 0,5 m) in all positions of the swing so that passengers are not endangered.
2. All connecting elements must be sufficiently secured by suitable means against unintentional loosening. Such parts must also be constantly checked. If necessary, this must be done while the ride is being operated. Railings must be secured so that they cannot be lifted out of their mountings.
3. The carrousel must be carefully underpinned. The support blocks must be kept as low as possible.  
For the main support blocks of the substructure (at the front and the rear end of the center structure vehicle) please note:  
Between substructure and support blocks a wood layer made of beech or oak must be inserted. The combination of steel to steel is only permissible if there are respective catches.
4. The maximum load in each gondola is 4 adults or 6 children (calculated payload = 300 kg/gondola). The passengers must be distributed as evenly as possible among the gondolas.
5. It is prohibited to lean out of the gondolas, to stretch out arms and legs, to smoke and to enter the gondolas with animals or with umbrellas, sticks or other bulky or pointed objects.  
During operation the passengers must sit still and hold on to the grips provided for this purpose. The head must be rested on the back- resp. headrest.
6.
  - a) In view of the acceleration and other forces which arise, persons suffering from spinal damage or who are currently being treated for spinal deficiencies must be excluded from the ride.
  - b) Children under 8 years of age and of a height of less than 137 cm (4 1/2 ft.) and persons who, e.g. because of handicaps cannot be held safely by the existing safety locking bars, are excluded from the ride.
  - c) Children from 8 to 10 years of age may only use the ride accompanied by a responsible adult.
  - d) Children under 14 years of age must never sit in the seats on their own.
  - e) Single passengers must use the outermost seats.
  - f) Drunken persons are not to be admitted to the ride.
7. Notices announcing the prohibitions and conditions contained in 4, 5 and 6 above must be prominently displayed and the operating personnel must ensure compliance with the provisions of 6 to 6f.
8.
  - a) It must be ensured that the safety locking bars are closed as



MASCHINENFABRIK

- 15"
- b) Persons of widely differing girth may not sit together on the same seat.
9. The operator must not switch on the drive power until
- a) all passengers are properly seated in the gondolas,
  - b) all seat safety bars are properly closed and locked and have been checked by the operating personnel. This check must not be carried out until after the "close safety bars" button has been pressed for the last time.  
(If the "close safety bars" button is pressed again, e.g. because more passengers have taken seats in the gondolas or similar, all safety locking bars must be checked once more to make sure that they are properly closed.)
  - c) the public have been warned via the public address system to leave the wheel and the safety zone (the area between the wheel and the red marking continuing the line of the small intermediate barrier) and this warning has been followed.
10. The operator must not start to lower the tilting arm until the operating personnel have clearly indicated to him that the part of the safety zone which is not visible to him is empty of people.
11. If tumultuous assemblies of people in the platform area give rise to fears that people may be pushed into the empty space under the wheel, operation of the ride must be discontinued and the platform cleared.
12. The condition and proper functioning of the following components must be checked daily prior to starting operation:
- a) The locking mechanism of the safety locking bars and of the cable pull and the springs for holding the bars in the open position.
  - b) The cushions on the safety locking bars and the anti-slip strips on the seats.
  - c) The locking brakes of the gondolas.
13. Each time the ride is re-erected and thereafter at weekly intervals the proper functioning of the parallel-switched valves for opening the locking mechanism of the safety locking bars must be checked in a function test.
14. Screwed connections must be inspected daily in random checks to ensure that they are in good working order. This is especially important in respect of the tightening torques prescribed by the manufacturers for the pretensioned screws and bolts.
15. The ride must be closed off in such a way that no nonauthorized persons can gain access to the area under the platform.
16. The following power control settings which were fixed during the acceptance testing must not be altered. In particular, the following values are valid for the ride without passengers:

Rotation drive aggregate:

Max. rotation speed

17 rpm



MASCHINENFABRIK

Max. oil pressure at constant speed approx. 80 bar

Max. oil pressure at 7.5° angle

on starting up approx. 250 bar

on braking approx. 240 bar

Tilting drive aggregate:

Lifting time approx. 17 secs

Lowering time approx. 19 secs

Oil pressure on lifting bottom/top approx. 170/60 bar

Oil pressure on lowering bottom/top approx. 155/55 bar

The factory setting which ensures that the gondola brakes automatically open at the latest at 10 rpm and can no longer be closed at speeds higher than 10 rpm must not be changed.

The pressure relief valves and the hose-break safety device must be left at their present settings.

17. If any modifications are effected in the circuit controlling the cylinder, but also after 5 years operation, the pressure arising in the cylinder must be measured for pressure peaks.
18. If the ride is to be operated at temperatures below 0°C, an "air drier" must be built into the air supply line to prevent the valves from icing up.
19. The manufacturer supplies the ride with an automatic program. For safety reasons the operator must not produce ride effects during manual operation which are different from those of the automatic program (i.e. constant acceleration and deceleration of the wheel is not permissible).

The ride must not be operated at speeds  $n > 12$  rpm for periods longer than 60 seconds.



MASCHINENFABRIK

Maintenance Instructions for Fiberglass Surfaces

We use only first-class materials to produce the surface finish of our fiberglass components. Although these require very little maintenance, they cannot do entirely without maintenance. To retain the brilliant surface gloss for a long time we recommend you to:

1. Clean the surfaces at least every 14 days with clear water and then polish with a leather cloth.
2. Never rub dust or dirt off the surfaces when dry.
3. Clean the surfaces with a solution of water and household washing-up liquid or similar as required but at the latest every 3 months; after drying, apply a good automobile wax and polish with a soft cloth.
4. If you use a high-pressure steam jet, never work with chemicals which are more aggressive than soapy water.
5. If you use a high-pressure steam jet with chemicals which comply with Point 4, wax and polish the surfaces again afterwards.
6. Stubborn spots and stains can be swiftly removed with moist acetone cloths; keep the contact time with acetone to a minimum.  
Immediately after working with acetone or cleaning benzene, wash the surface well with clear water and then wax and polish.