

MFG: FREDERIKSON
ENTERPRISES, INC.
NAME: SUPER SLIDE
TYPE: ATTRACTION

SLIDE BULLETIN NO.1 APPLIES TO ALL FUN SLIDES

DATE: DECEMBER 4, 1995

SUBJECT: RAILINGS ON STEPS

It has been brought to our attention that a small child has been able to slip through the railings on the stairs of the Fun Slide. Therefore it is required that all owners of Fun Slides perform the modifications described in this bulletin.

The modification consists of welding 1 inch square tubing into the hand railings, the entire length of the steps leading to the top of the slide, so that no opening is greater than 4 inches. Also on the structure of the slide on the left side going up the stairs, there should be 3/16 x 1 inch flat bars 4 inches apart the entire length of the steps.

NOTE; All work must be performed by competent, qualified welder, capable of welding aluminum.

RECEIVED

DEC 11 1995

BUREAU OF
FAIR RIDES INSPECTION

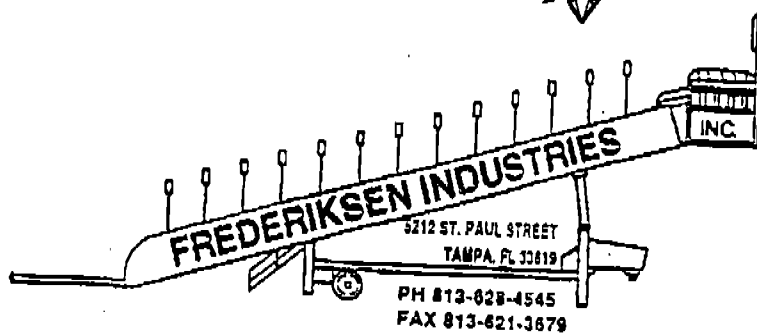

SLIDE BULLETIN NO.2 APPLIES TO ALL FUN SLIDES

DATE: DECEMBER 4, 1995

SUBJECT: LANE DIVIDERS AT TOP OF SLIDE.

It has been brought to our attention of an incident involving the divider bars at the entrance to the slide lanes. Therefore it is required that all owners of Fun Slides perform the following modifications described in this bulletin.

The modification consists of welding a solid piece of aluminum into the center of the divider.

Note; all work must be performed by a competent qualified welder, capable of welding aluminum.

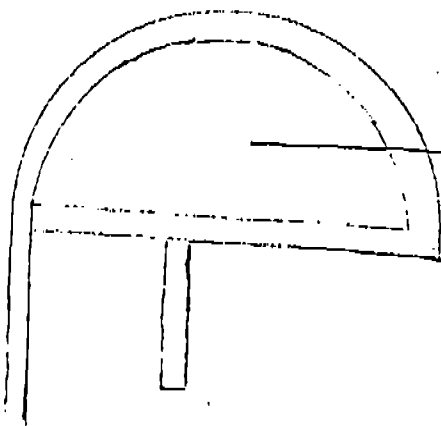

Fill entire opening.

RECEIVED

DEC 11 1995

BUREAU OF
FAIR RIDES INSPECTION

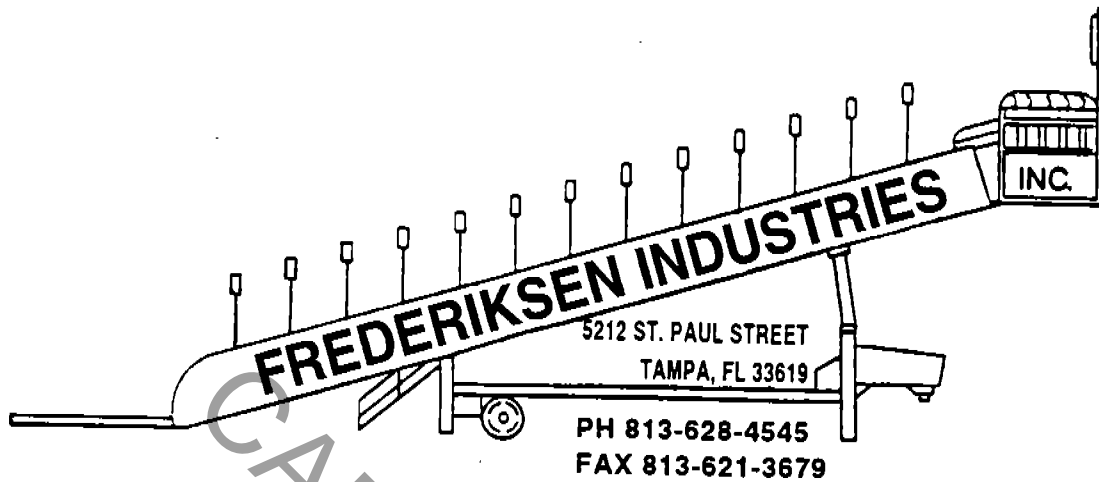

OPERATIONS, MAINTENANCE AND INSTRUCTIONS MANUAL

**FOR THE
KIDDIE FUN SLIDE**

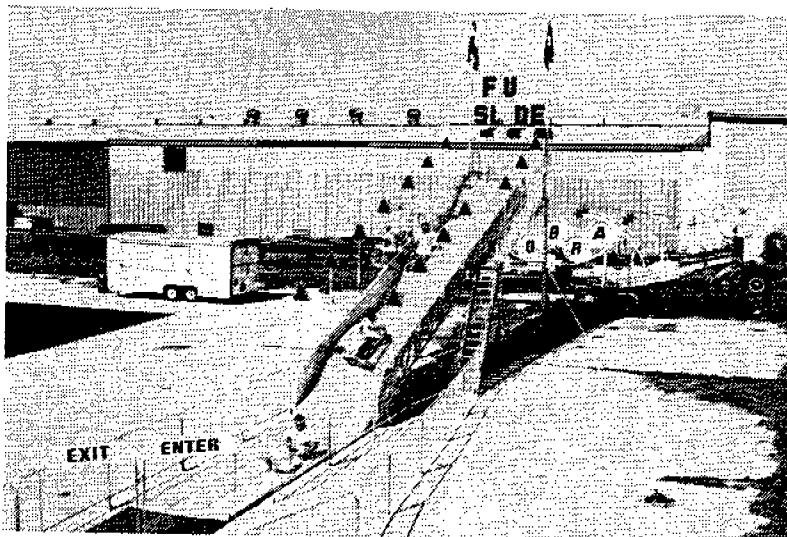

TABLE OF CONTENTS

	PAGE
INTRODUCTION.....	1
HYDRAULIC SYSTEM	
ELECTRIC HEATER SYSTEM	
SIGN CONTROL MODULE.....	2
SET-UP OPERATION.....	3-4-5
OPERATIONAL PROCEDURES AND CHECKLIST.....	11
OPERATION OF THE DRY SLIDE.....	12
ILLUSTRATIONS:	
FIGURE 1-SKETCH OF SLIDE ASSEMBLED IN OPERATING POSITION.....	6
FIGURE 2-SKETCH OF SLIDE RACKED FOR TRANSPORTING....	7
FIGURE 3-SKETCH OF FRONT OF SLIDE ASSEMBLY.....	8
FIGURE 4-SKETCH OF ROLL-OUT SECTION MATING WITH FRONT SECTION.....	9
FIGURE 5-SKETCH OF GROUND SECTIONS AND PROPER PLACEMENT OF BLOCKING.....	10
FIGURE 6-SKETCH OF FENCING LAYOUT.....	13

INTRODUCTION

The amusement attraction known as the KIDDIE FUN SLIDE, consists mainly of a trailer-mounted aluminum framework which supports a three-lane 60 foot long fiberglass sliding area. The top section is raised into position by a hydraulic cylinder and supported by two stanchions with turnbuckles. The center section is then rolled back and hoisted into position using two winches permanently affixed to the front of the trailer, then it is bolted into place. The bottom section is then fitted together and pinned to the roll-out section.

HYDRAULIC SYSTEM

The hydraulic system consists of a model #5W034-3 (2.35 gpm) pump and a 6K045F 1hp electric motor from Dayton. The control valve is a Gresen model 300 2-way valve. The fluid tank is a Dayton 5-gallon model with a spin-on filter assembly.

The cylinder is a single stage type with a chrome-plated ram to resist rust.

The recommended oil to use is a mineral-based hydraulic oil. The recommended change interval is every 25 hours or once yearly, whichever comes first.

ELECTRIC HEATER SYSTEM

This slide is equipped with a heating system that is built in to the fiberglass. This system is virtually maintenance-free. It is designed for use only in high humidity type situations. It will not control moisture from rain, etc.

SIGN CONTROL MODULE

This slide is equipped with a 3-channel chaser-flasher - computer sign control module from Rocox. The chase and flash speeds are easily set by individual controls.

SET UP OPERATION

NOTE: The trailer must be blocked at all four corners and leveled from side to side and front to rear before beginning set up operations!

CAUTION: You must remove the two 1" pins from brackets at top of 4" square uprights at rear of trailer before raising front section. Failure to do so will result in serious damage to the ride.

Set up procedure: First, install outriggers into brackets at sides of 4" uprights at rear of trailer using 1 1/4" by 6 1/2" pins and R-keys. Install 1" turnbuckles from landing gear legs to outriggers. Then block underneath the outriggers and tighten turnbuckles. (Fig. 3). While front section is down, remove pins from sign and clamps from lights. Fold sign up and pin into position using two 3/4" by 6" pins and R-keys at bottom of sign legs. Next, fold lights up and pin into position using 3/8" L-shaped pins and R-keys inserted into light brackets.

Roll-out section:

Remove two(2) 3/4" bolts from front and two(2) 3/4" bolts from rear of roll-out section. Roll back 3-4 feet only-- then install the adjustable dollies into brackets at each side of rear of section using 3/8" bolts and nuts to secure in place.

NOTE: To facilitate ease of rolling on ground it is advisable to place two pieces of plywood 2 ft. by 8 ft. approx. 14 to 22 feet behind trailer in line with dolly wheels.

(cont.)

Set up operation (cont.)

Roll section back and down to ground until approx. one foot at front of section is left on trailer.

NOTE: At this time it is easier to fold the lights up on this section, using the same procedure as the top section. Chock wheels if necessary to prevent rolling. Next, raise hydraulic cylinder up and pin into bracket in top section with 7/8" Grade 9 bolt, nut, and key. After hooking up electrical power, turn main circuit breaker on and the breaker for the hydraulic pump. Raise slide approx. 1 foot by use of the control valve lever and pin stanchions to brackets under the canopy using 1 1/4" by 3 1/4" pins and R-keys. Then, fasten the 3/4" turnbuckles to the top of the stanchions using two 5/8" by 3" galvanized pins and R-keys. Next, raise the slide the rest of the way up and pin the stanchions into place using the other 1 1/4" by 3 1/4" pins and R-keys.

NOTE: Do not let stanchions drag on trailer deck when raising. Cross the two 3/4" turnbuckles and pin to stanchions using two 5/8" by 3" galvanized pins and R-keys. Tighten the turnbuckles evenly to take slack out of stanchions- just good and snug- DO NOT OVERTIGHTEN!! See (fig. 3).

Fasten winch cables to eyebolts on lower front bar of roll-out section. Hoist up and move back as needed to meet the front section squarely----THIS IS A MUST----

NOTE: Use the two dollies to adjust up or down as needed to make the two frameworks meet squarely. (fig. 4)

(cont.)

Set up operation (cont.)

The lip of the fiberglass on the roll-out section must be underneath the fiberglass on the front section. Now install the two(2) 7/8" by 2-1/2" bolts and nuts into the mating brackets facing inward from the two frameworks. Tighten bolts securely.

Bottom (ground) section:

Line the ground section up to the roll-out section and pin together with two (2) 3/4" by 5" pins and R-keys. The fiberglass lip of the ground section must be underneath that of the roll-out section.

CAUTION: Blocking must be placed across under the cross-braces where these two sections meet as a means of support.

Slide ladder: The slide ladder is fitted to the slide stairway by use of a 7/8" by 17-1/2" pin and R-key. The ladder will have to be angled out away from the roll-out section somewhat for the pin holes to line up.

Canopy: Raise the canopy up and pin into position using the proper L-shaped 1/2" pins and R-keys. Install safety bars around the canopy and pin together using the proper L-shaped 1/2" and 3/8" pins and R-keys.

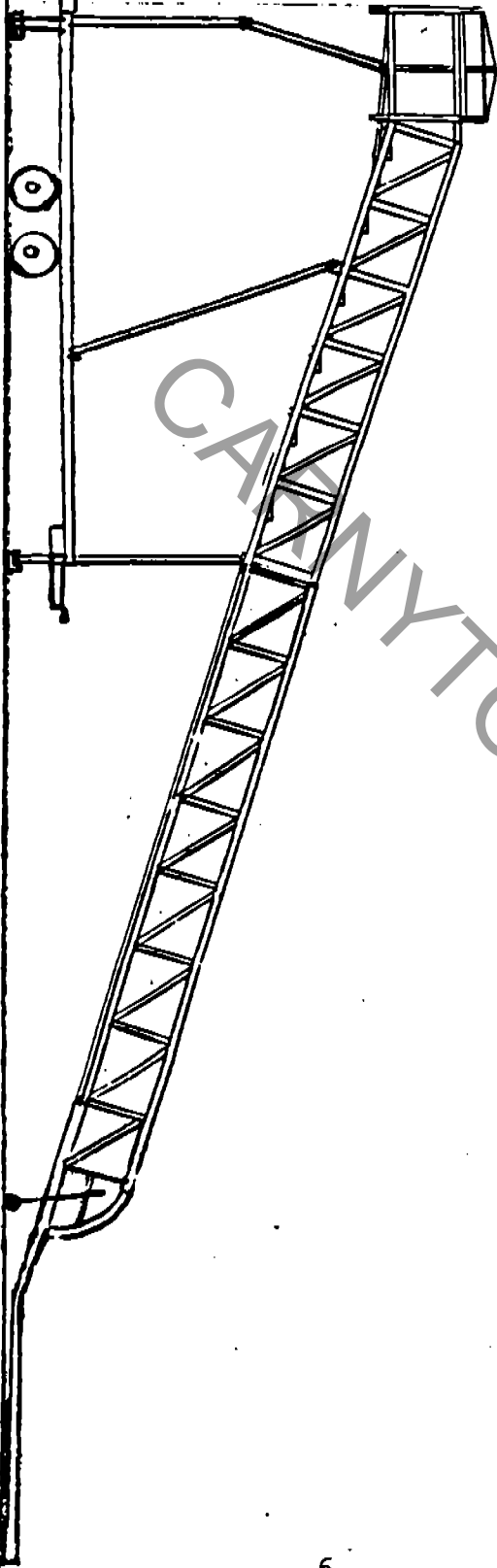

SKETCH OF SLIDE ASSEMBLED
IN OPERATING POSITION

FIGURE 1

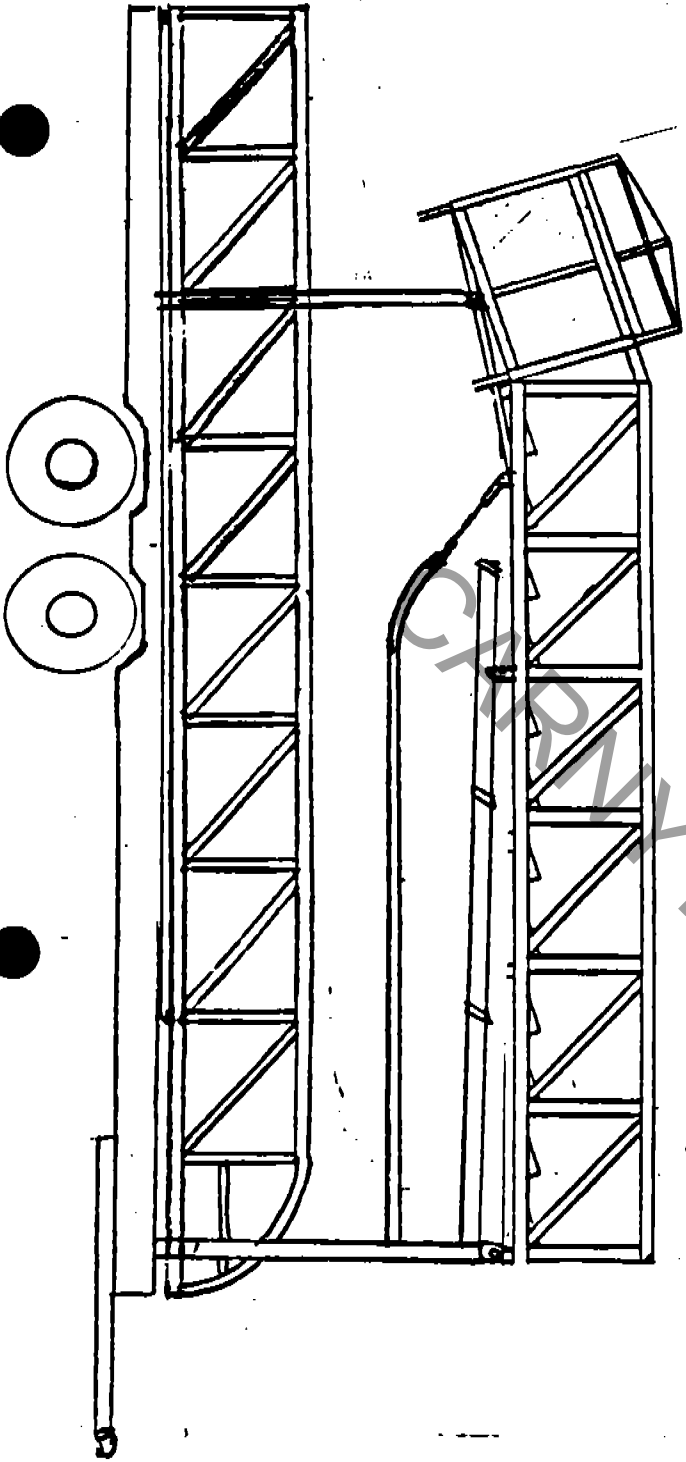
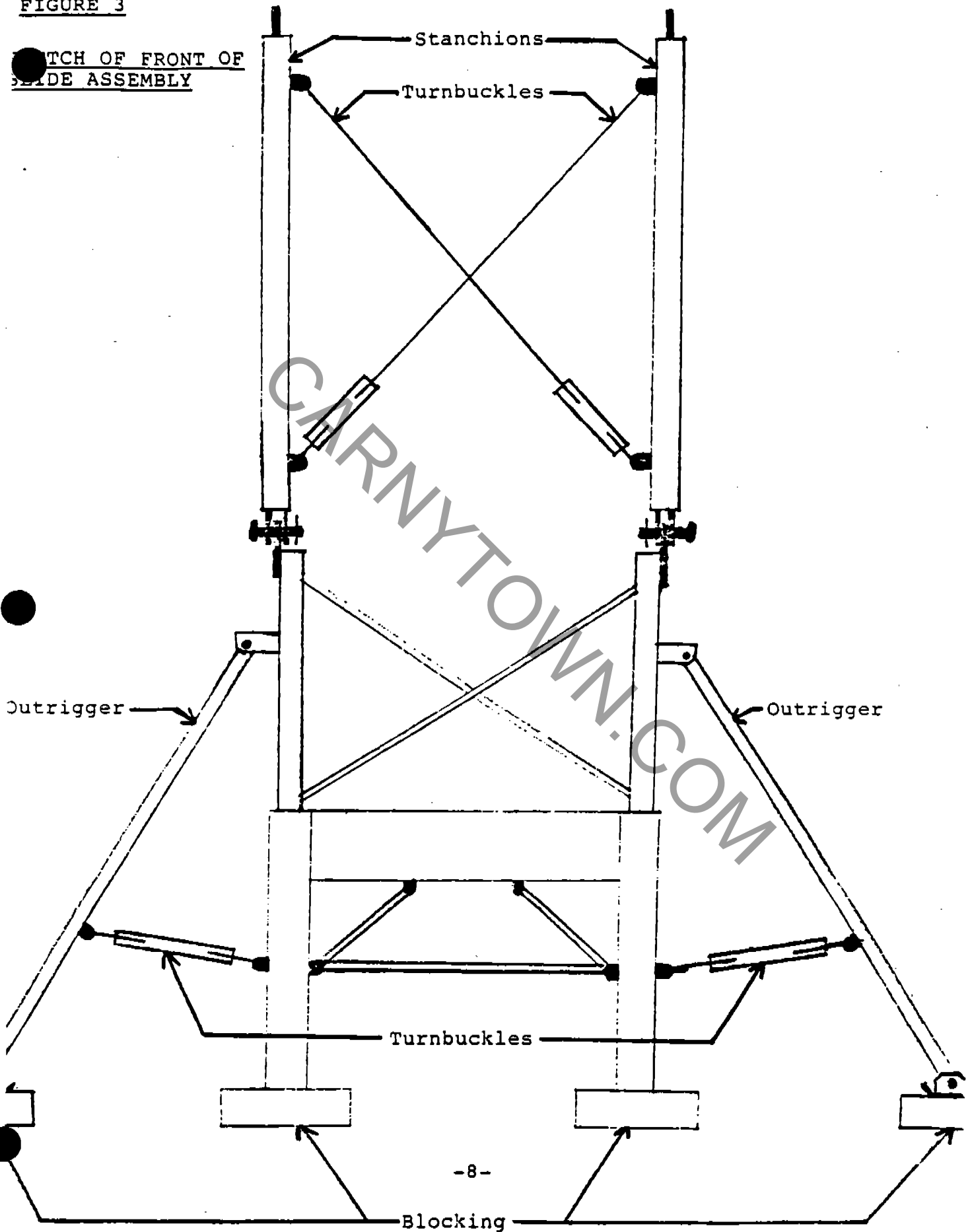

FIGURE 2

SKETCH OF SLIDE RACKED
FOR TRANSPORTING

FIGURE 3

SECTION OF FRONT OF
SIDE ASSEMBLY



SKETCH OF ROLL-OUT SECTION
MATING WITH FRONT SECTION

INSERT BOLTS AT THIS
POINT ON EACH SIDE

THESE TWO FRAMEWORKS
MUST MEET SQUARELY

9

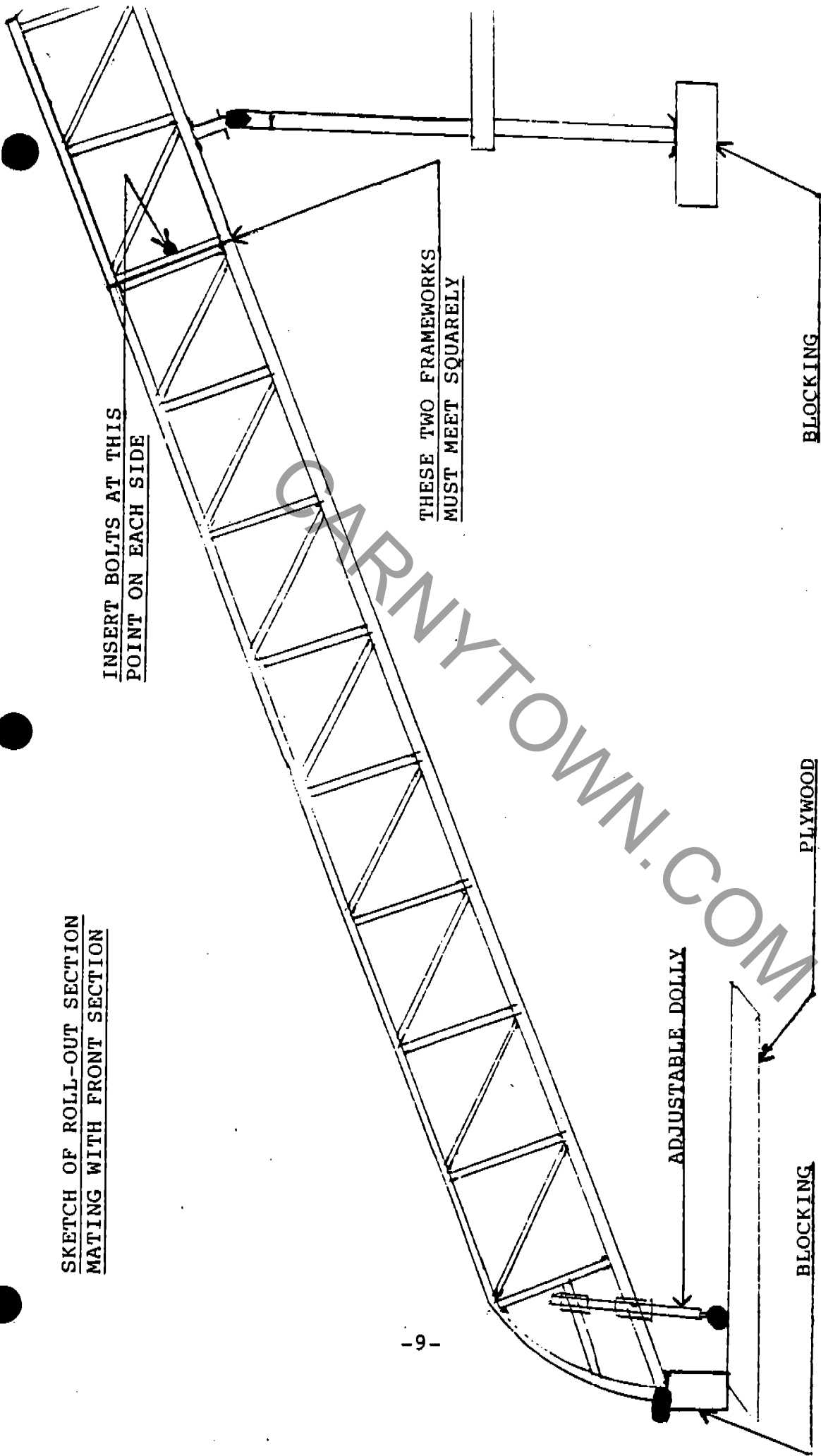

BLOCKING

PLYWOOD

ADJUSTABLE DOLLY

BLOCKING

FIGURE 5

SKETCH OF GROUND SECTION AND
PROPER PLACEMENT OF BLOCKING

CARNYTOWN.COM

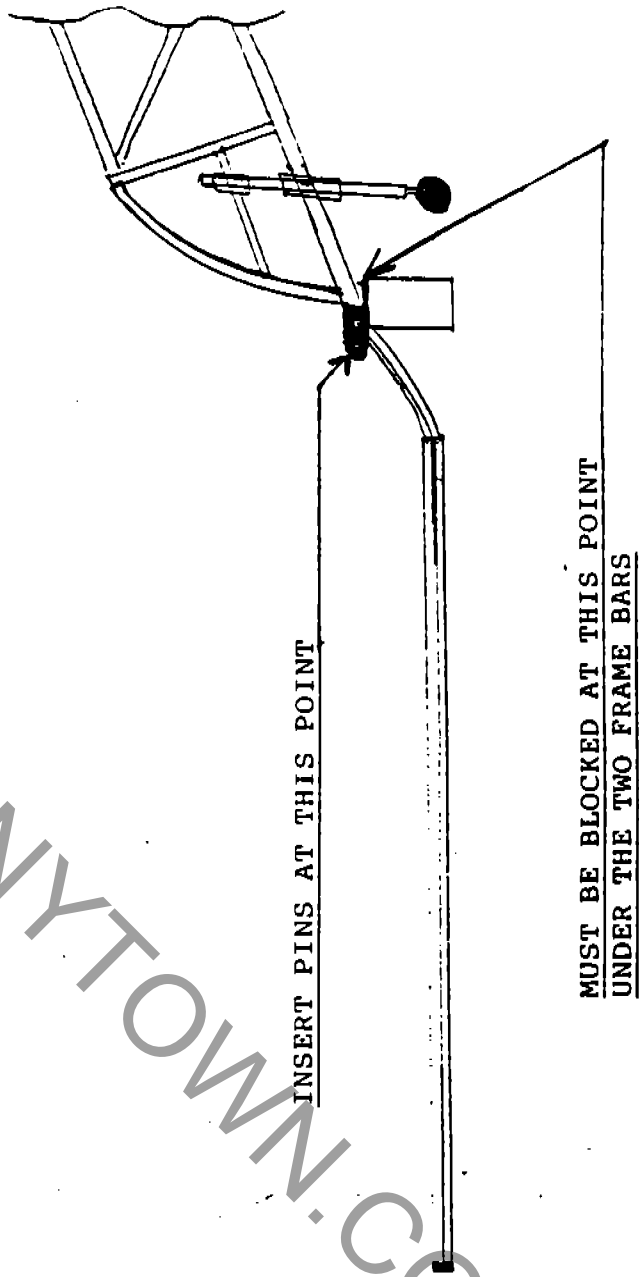

OPERATIONAL PROCEDURES AND CHECKLIST

Description of the area needed to set up the slide:

1. The surface on which the ride is set up must be hard enough so that no settling of the Slide will occur.
2. The surface on which the ride is set up must be level so that the Slide can be properly leveled.
3. When the Slide is in the operating position, people on the Slide should not be able to reach out and touch trees, buildings, light or telephone poles, signs or power lines, etc.

Checklist before operating Slide:

1. Pins and R-keys.....Daily for condition and proper placement.
2. Steps and handrails.....Daily for condition and pins and R-keys
3. Plugs, electrical boxes, and wire.....Weekly
4. Circuit breakers.....Monthly

Slide care:

1. Use a product such as Johnson's Pledge to clean the surface of the Slide.

CAUTION: DO NOT use wax or polish to make the Slide faster!!

2. Wash occasionally with a very mild soap.

NOTE: Do not use any type of abrasive.

Starting gates:

This Slide is constructed so that the starting gates are left in their proper position and permanently pinned and keyed, even during transportation.

OPERATION OF THE DRY SLIDE

1. A minimum of two operators shall operate the Slide if ten (10) or more persons are utilizing Slide or in Slide area. The following criteria shall apply while the Slide is in operation:

(a) One person on top of the Slide to:

- 1) Regulate the flow of sliders so that there are no collisions at the bottom of the Slide.
- 2) Make sure all riders are sitting and positioned properly before sliding.

NOTE: All sliding shall be done in an upright, sitting position, with feet in the mat pocket, and hands holding up the sides of the sliding mat.

CAUTION: Absolutely no sliding shall be done backwards, or in a prone or standing position.

- 3) All children must be 42" tall to ride alone.
- 4) Very small children have a tendency to "fishtail" and shall slide with an adult.

(b) One person at the bottom of the Slide.

- 1) Regulate the traffic up the steps.
- 2) Make sure people use the handrails as they climb the steps
- 3) Assist people in getting up after completing their ride.
- 4) Collect the sliding mats.

SKETCH OF FENCING LAYOUT

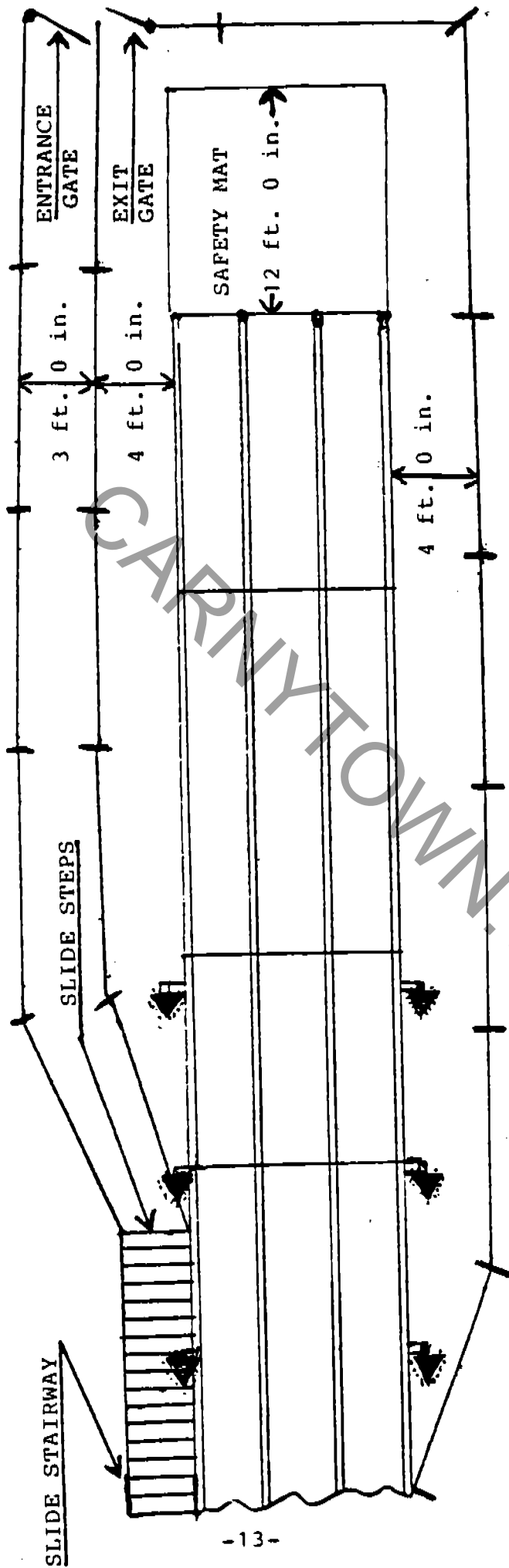

SUGGESTED FENCE LAYOUT PLAN

CARNYTOWN.COM

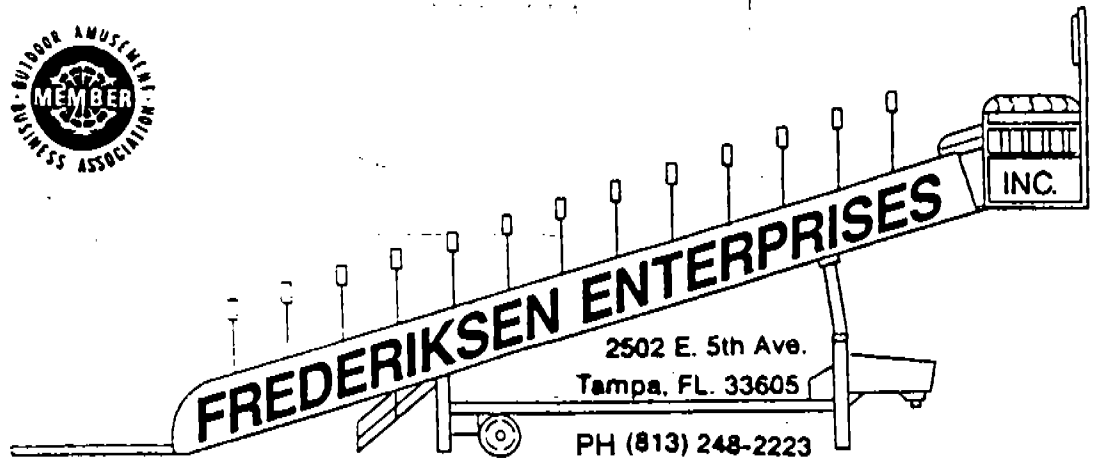

**OPERATIONS, MAINTENANCE
AND INSTRUCTIONS
MANUAL
FOR THE
SUPER FUN SLIDE**

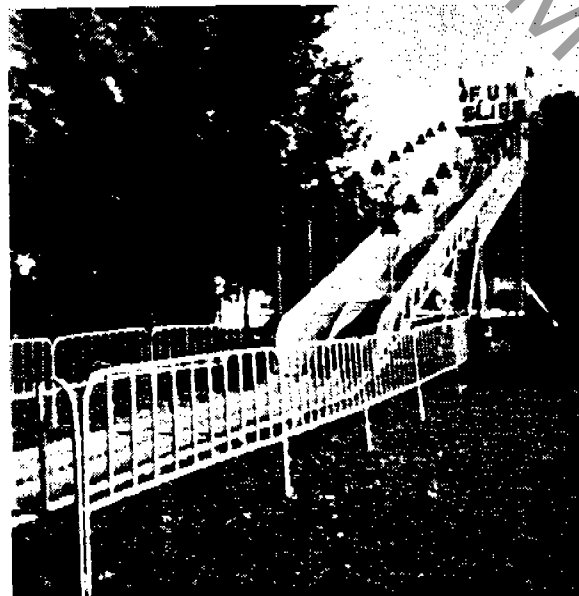

INTRODUCTION

The amusement attraction known as the SUPER FUN SLIDE, (figure 1), consists mainly of a trailer-mounted aluminum framework which supports a three-lane 90 foot long fiberglass sliding area. The top section is raised into position by a hydraulic cylinder and supported by two stanchions with turnbuckles. The center section is then rolled back and hoisted into position using two winches permanently affixed to the rear of the trailer, then bolted in place. The bottom two sections are then pinned together and fitted to the roll-out section.

SET UP OPERATION

NOTE: The trailer must be blocked at all four corners and leveled from side to side and front to rear before beginning set up operations!

CAUTION: You must remove the $1\frac{1}{4}$ " pins from brackets at top of 4" square uprights at front of trailer before raising front section. Failure to do so will result in serious damage to the ride.

Set up procedure: First, install outriggers into brackets at sides of 4" uprights at front of trailer using $1\frac{1}{4}$ " by $6\frac{1}{2}$ " pins and R-keys. Install 1" turnbuckles from landing gear legs to outriggers. Then block underneath the outriggers and tighten turnbuckles. (Fig. 3) While front section is down, remove pins from sign and clamps from lights. Fold sign up and pin into position using two(2) $3/4$ " by $5\frac{1}{2}$ " pins and R-keys at bottom of sign legs. Next, fold lights up and pin into position using L-shaped $3/8$ " pins and R-keys inserted in light brackets.

Next, remove pins from rear bracket holding stanchions.

NOTE: do not allow stanchions to drag on trailer while raising.

After hooking up electrical power, turn main circuit breaker on and the circuit breaker for the hydraulic pump. Raise slide into position by use of the pump control valve and pin stanchions to bracket at top of 4" uprights at front of trailer, using $1\frac{1}{4}$ " by $3\frac{1}{4}$ " pins and R-keys.

(cont.)

Set up operation (cont.)

The lip of the fiberglass on the roll-out section must be underneath the fiberglass on the front section. Now install the two (2) 3/4" by 2½" bolts, lockwashers, and nuts into the mating brackets facing inward from the two frameworks. Tighten bolts securely.

Bottom (ground) sections:

Line the longer (curved) section up to the roll-out section and pin together with two (2) 3/4" by 3" pins and R-keys. The fiberglass lip of the ground section must be underneath that of the roll-out section.

CAUTION: Blocking must be placed across under the cross-braces where these two sections meet as a means of support.

The last section just fits together with the previous section by use of two square pockets where they meet.

NOTE: It might be necessary to use some small blocking at this point to level these sections if they do not meet just right.

Slide steps: The slide steps are fitted to the slide stairway by use of a 7/8" by 17½" pin and R-key. The steps will need to be angled out away from the roll-out section somewhat to make the pin holes line up.

Canopy: Raise the canopy up and pin into position using the proper L-shaped 3/8" pins and R-keys. Install safety bars around the canopy and pin together using the proper L-shaped 3/8" pins and R-keys.

FIGURE 2

SKETCH OF SLIDE RACKED
FOR TRANSPORTING

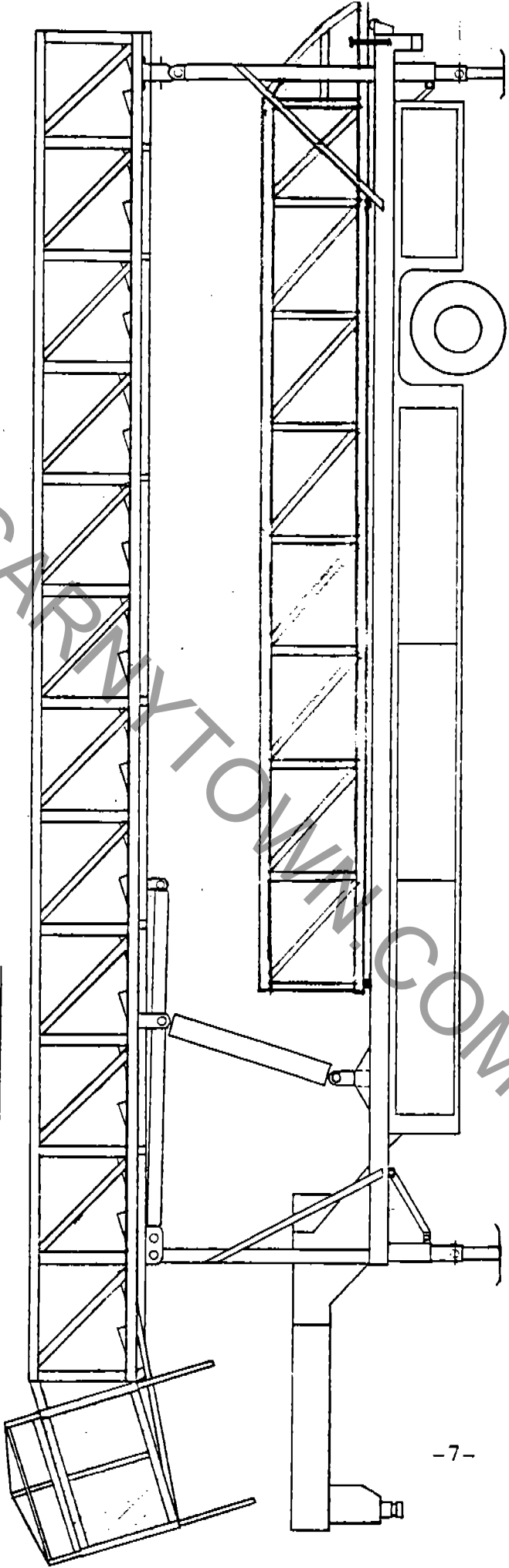

OPERATIONAL PROCEDURES AND CHECK LIST

Description of the area needed to set up the Slide:

1. The surface on which the ride is set up must be hard enough so that no settling of the Slide will occur.
2. The surface on which the ride is set up must be level so that the Slide can be properly leveled.
3. When the Slide is in the operating position, people on the Slide should not be able to reach out and touch trees, buildings, light or telephone poles, signs or power lines.

Check list before operating Slide:

1. Pins and snap keys.....Daily
for condition and proper placement
2. Steps and handrails.....Daily
for condition and pins and keys
3. Plugs, electrical boxes and wire.....Weekly
4. Circuit breakers.....Monthly

Slide care:

1. Use a product such as Johnson's Pledge to clean the surface of the Slide.

CAUTION: DO NOT use wax or polish to make the Slide faster!!

2. Wash occasionally with a very mild soap.

NOTE: Do not use any type of abrasive.

Starting gates:

This Slide is constructed so that the starting gates are left in their proper position and permanently pinned and keyed at all times, even during transportation.

FIGURE 6

SKETCH OF FENCING LAYOUT

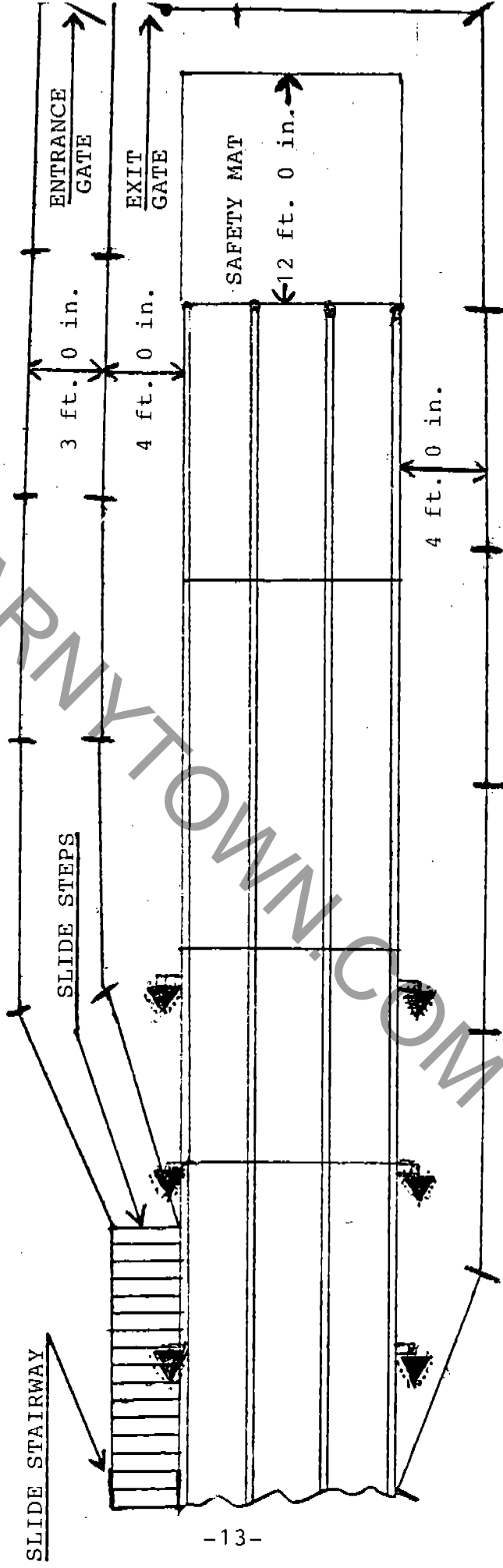

SUGGESTED FENCE LAYOUT PLAN

Z E N D A R

OPERATION
AND
MAINTENANCE
MANUAL

DARTRON INDUSTRIES, INC.

2725 19th Street S.E.
P.O. Box 13114
Salem, OR 97309

(503) 362-2341

T A B L E O F C O N T E N T S

	<u>PAGE</u>
Specifications	2
Power Supply Requirements	2
System Override and Emergency Procedures	3
Control Console Diagram	6
Operating Instructions - Manual Mode	7
Operating Instructions - Automatic Mode	9
Lubrication Drawing	11
Lubrication Specifications	12
Lubrication Maintenance Schedule	13
Space Diagram	14
Hydraulic Information	15

SYSTEM OVERRIDE AND EMERGENCY PROCEDURES

I. Electrical or hydraulic power is interrupted while boom is in up position.

A. Wheel is not tilted.

When electrical or hydraulic power is interrupted, holding valves located on the boom lift cylinders will close trapping hydraulic fluid in the lift cylinders and maintaining the boom at that location. To lower boom without hydraulic or electrical power locate the lift cylinder valve override handle located inboard of cooling fan on the rear of the hydraulic fluid storage reservoir. The override handle is about 5" long with a rounded end. Rotate the handle 90 degrees. This action will allow hydraulic fluid to slowly exit the lift cylinders and allow the boom to gently return to the boom rest pad. **CAUTION:** After lowering boom return override handle to closed position. With override handle in open position boom cannot be raised.

B. Wheel is tilted.

When electrical or hydraulic power is interrupted, or when RPM's drop below a preset level holding valves on the boom lift cylinders will be bypassed hydraulically, allowing fluid from the base of the lift cylinders to fill the rod end of the drag link cylinder. This in turn brings the wheel to the level position.

To lower boom locate the lift cylinder valve override handle inboard of the cooling fan. Rotate the handle 90 degrees. This will allow fluid to exit the lift cylinders and will slowly lower boom.

CAUTION: RETURN OVERRIDE HANDLE TO CLOSED POSITION. BOOM CANNOT BE RAISED WITH HANDLE IN OPEN POSITION.

II. Ride occupant creates a situation requiring the ride motion to be stopped or occupant be removed immediately

Using the operator's console, switch to manual mode. Level the wheel with the tilt control. Once wheel is level, turn rotation switch off. When wheel is no longer rotating, lower boom with joystick.

III. Ride operator sees an electrical problem and needs to stop the ride and interrupt electrical power to hydraulic system.

Push down mushroom head button labeled EMERGENCY STOP. Breaker for

IX. If all the above procedures fail and the wheel stops or slows below 20 RPM while in the Tilt mode, passengers will be held safely in their cages by the safety belts fastened across the front of the cell.

The operator should push the emergency STOP mushroom switch and go quickly to boom override valve and lower the boom. Safety cables will level the wheel allowing passengers to be safely removed.

CARNYTOWN.COM

OPERATING INSTRUCTIONS

1. MANUAL OPERATION OF RIDE

PLACE MODE SELECTION SWITCH IN MAN (manual) POSITION.

1. To start motor and hydraulic system push button labeled HYDRAULIC SYSTEM ON. Allow system to warm up until the temperature of the hydraulic system reaches 50 degrees. Hydraulic fluid will warm up before temperature gauge indicates 50 degrees because the gauge is exposed to the open air. Hydraulic pump will quiet down when fluid is warm enough.
2. Place switch labeled ROTATION in the FWD (forward) position. Rotation will not occur at this time. (When rotation does begin, the FWD position will cause the wheel to rotate in a counter clockwise direction.)
3. Move BOOM LIFT joystick to the UP position. Boom will rise until it reaches its maximum height and then will stop by itself. Release joystick after upward movement of the boom stops.
4. Wheel rotation will start at this time. When tilt speed is achieved, the red diode labeled NO TILT will go out, and the green diode labeled OK TILT will illuminate.
5. Operator must observe all passengers and verify that all are in cages with safety belts fastened. Operator must not tilt the wheel until observing that all passengers are in cages with safety belts fastened.
6. When the OK TILT diode illuminates, move the TILT joystick to the TILT position. This action will cause the wheel to tilt. When the tilt position is achieved, the tilt action will stop by itself. NOTE: The wheel will not tilt until adequate wheel speed is achieved.
7. NOTE: The boom cannot be lowered unless the wheel is level. To level the wheel, move the TILT joystick to the LEVEL position. The wheel tilt movement will stop by itself when the wheel is level.
8. To lower the boom move the BOOM joystick to the DOWN position. As soon as downward movement starts, the wheel will cease rotating. As-

II. AUTOMATIC OPERATION OF RIDE

PLACE MODE SELECTION SWITCH IN AUTO POSITION

1. To start motor and hydraulic system push button labeled HYDRAULIC SYSTEM ON. Allow system to warm up until the temperature of the hydraulic system reaches 50 degrees. Hydraulic fluid will warm up before temperature gauge indicates 50 degrees because the gauge is exposed to the open air. Hydraulic pump will quiet down when fluid is warm enough.
2. Place switch labeled ROTATION in the OFF position.
3. Move BOOM joystick to the UP position. Boom will rise until it reaches its maximum height and then will stop by itself. Release joystick after upward movement of the boom stops.
4. Wheel rotation will start at this time. When tilt speed is achieved, the red diode labeled NO TILT will go out, and the green diode labeled OK TILT will illuminate.
5. Operator must observe all passengers and verify that all are in cages with safety belts fastened. Operator must not tilt the wheel until observing that all passengers are in cages with safety belts fastened.
6. When the OK TILT diode illuminates, move the TILT joystick to the TILT position. This action will cause the wheel to tilt. When the tilt position is achieved, the tilt action will stop by itself. NOTE: The wheel will not tilt until adequate wheel speed is achieved.
7. After a pre-set number of seconds, the wheel will automatically return to the level position and stop rotating.
8. To lower the boom move the BOOM joystick to the DOWN position. Use the BRAKE ON switch to stop the wheel rotation so that the exit and entry doors are above the exit and entry platforms.
9. When the boom reaches the boom rest, downward movement will stop by itself. Release the joy stick.

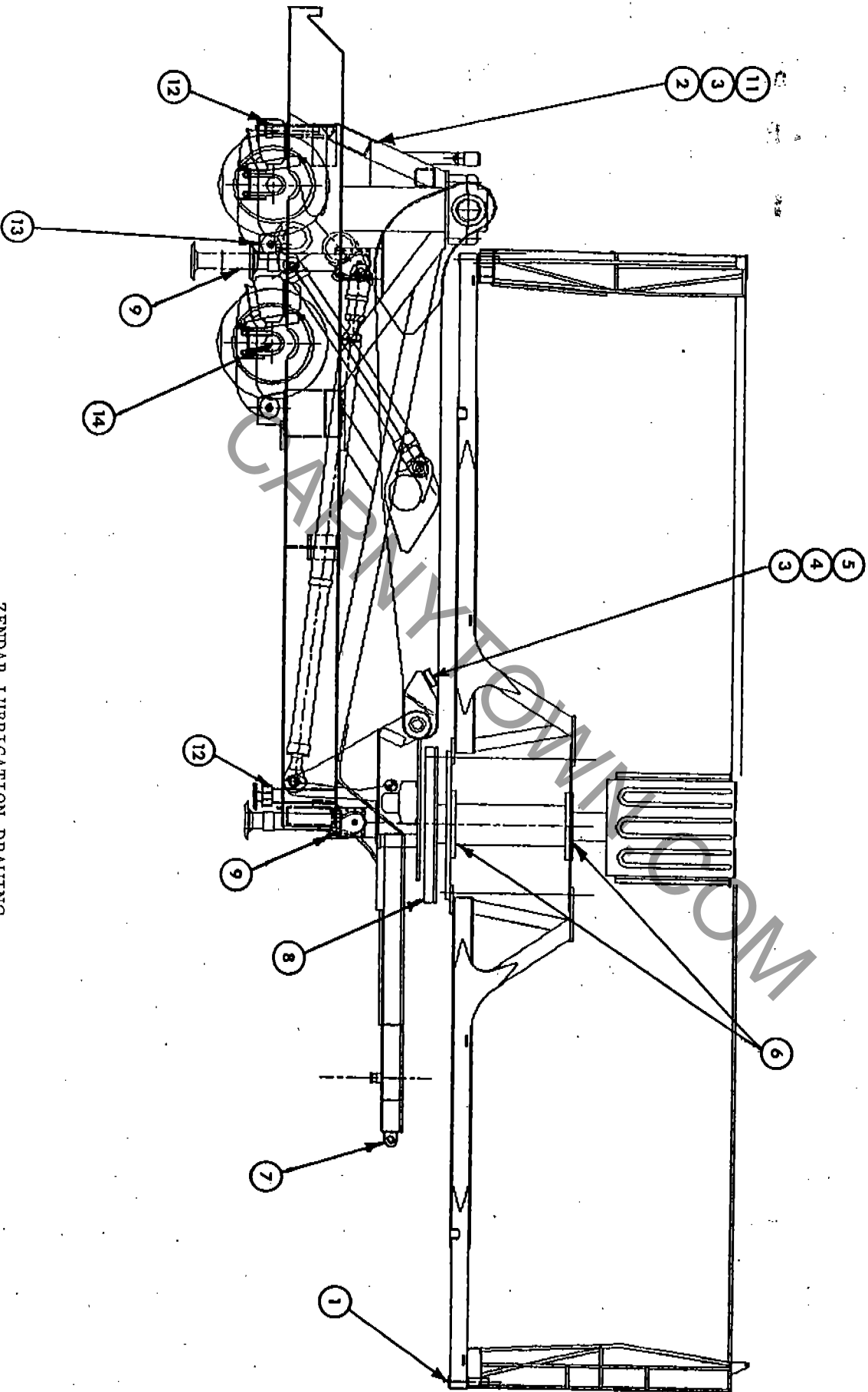

ZENDAR LUBRICATION DRAWING

LUBRICATION MAINTENANCE SCHEDULE

ITEM	TYPE OF LUBRICANT	FREQUENCY
1	Cage assembly pivot pin	Grease Monthly
2	Boom pillow block bearings	Grease Daily*
3	Wire arm ends	Grease Daily *
4	Upper cylinder pin	Grease Daily *
5	Boom platform pivot pin	Grease Daily *
6	Upper & lower center hub bearings	Grease Weekly.
7	Front storage boom bearings	Grease Monthly
8	Main drive gear	Finion Grease Monthly
9	Landing gear (3 each)	Grease Monthly
10	Digger screw jack	Grease Monthly
11	Lower cylinder pin	Grease Daily *
12	Front & rear screw jacks	Grease Monthly
13	Rear brake activators (8)	Grease Monthly
14	Axles	Gear Oil Check Daily
15	Hydraulic Tank	Hydraulic Fluid Check Daily

* On Manifold Block

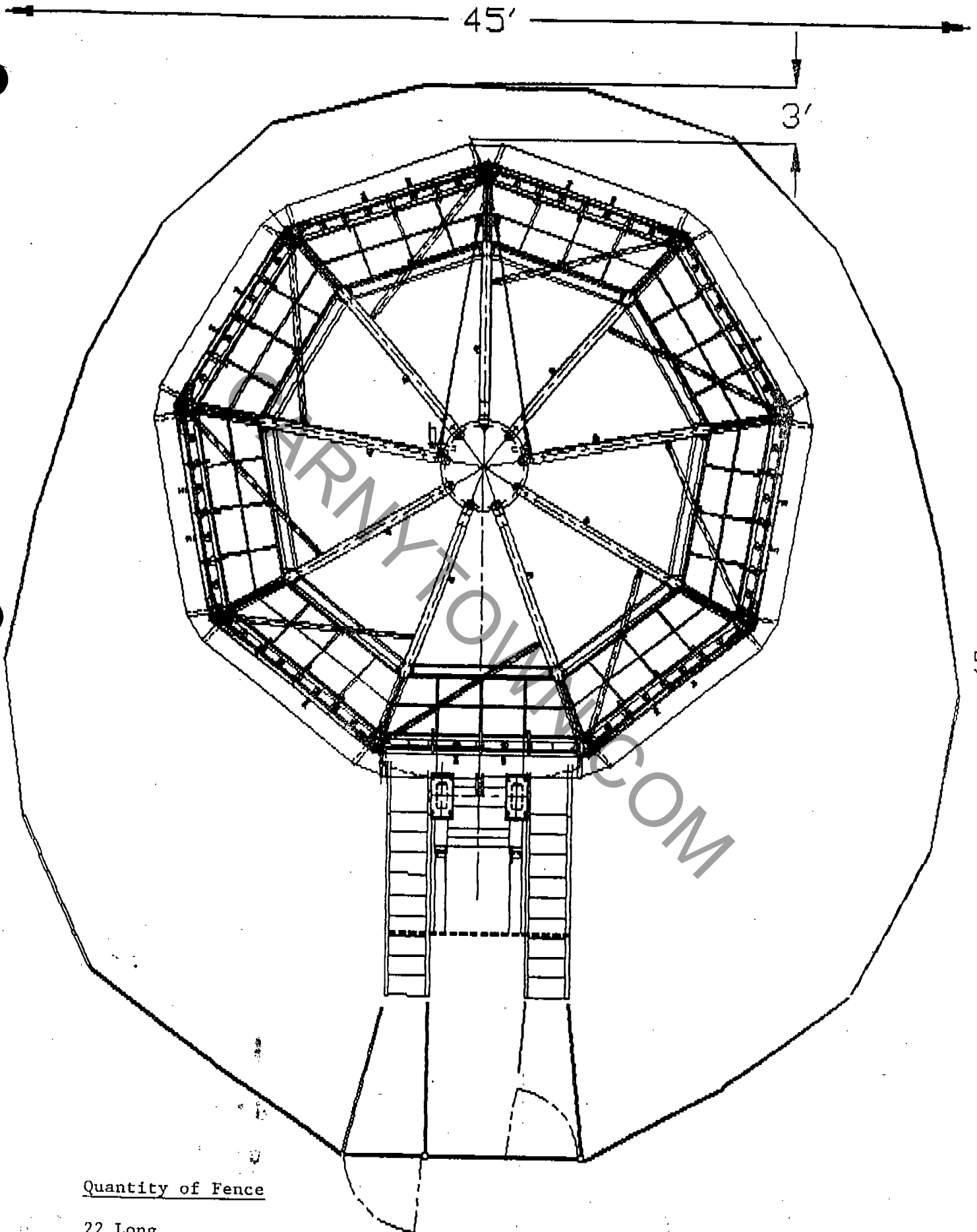

Quantity of Fence

- 22 Long
- 2 Short
- 2 Gates

SPACE DIAGRAM

RECOMMENDED LUBRICANTS

BRAND	GREASE	FINION	HYDRAULIC OIL	GEAR OIL
Chevron	Ultra Duty	Open gear	150 46	RPM Universal
Castrol	Starplex	Lexolad	Range Oil	MultiGear
Shell	SOH 460	ELE 15M	HD-80M90	Multi Tube
Fennell	Penitex	N/A	Fennell	AM 46
R.P.	N/A	N/A	HLP HD 46	Transgear
Valvoline	N/A	N/A	043	#838
Amsoil (Synthetic)	Multi-Purpose GLO	N/A	AHO	AGR
			15046	80M90

N/A = Not Available

CARNYNYN.COM

CARNYTOWN.COM

10. If the doors do not line up with the loading platforms, select the direction of rotation needed by placing the ROTATION switch in either the FORWARD or REVERSE position. Depress the JOG button. The wheel will rotate while the button is depressed. Releasing the JOG button will set the brake and stop wheel rotation.

CARNY TOWN.COM

the BRAKE ON switch to stop the wheel rotation so that the exit and entry doors are above the exit and entry platforms.
When the boom reaches the boom rest, downward movement will stop and reverse the JOY stick.
If the doors do not line up with the loading platforms, select the direction of rotation needed by placing the ROTATION switch in either the FORWARD or REVERSE position. Depress the JOY button. The wheel will rotate while the button is depressed. Releasing the JOY button will set the brake and stop wheel rotation.

start

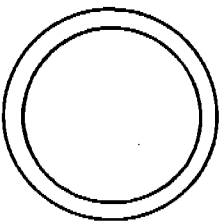

ROTATION

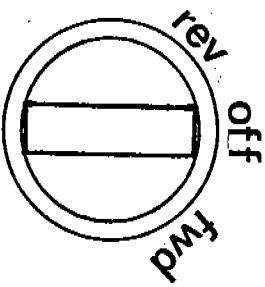

TILT

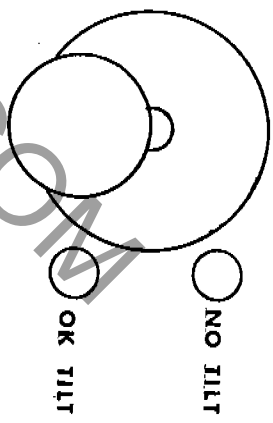

EMERGENCY

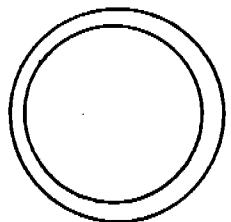

HYDRAULIC

SYSTEM

stop

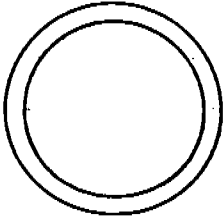

LEVEL

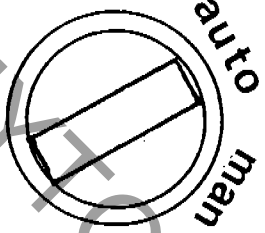

PUSH TO STOP

Zendar

BOOM

up

down

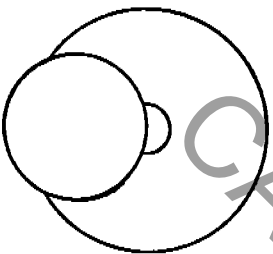

JOG

OPERATE WITH
BRAKE ON AND
ROTATE SELECTED

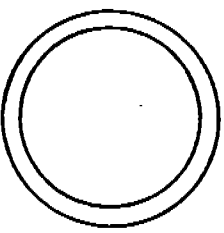

BRAKE

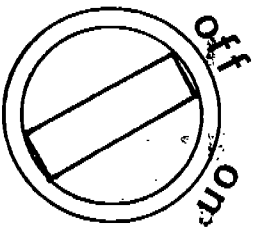

VIII. If wheel RPM's drop below 20 RPM, the wheel will automatically go into the free wheel mode and return to the level position.

B. If the wheel does not respond to the Tilt/Level joystick, move rapidly to the boom override handle and lower the boom. As the boom lowers, cables between the spindle base and the boom will tighten. These safety cables will prevent the sweeps from hitting the boom and will cause the link cylinder to collapse and allow the wheel to return to a level position.

A. Push the emergency STOP mushroom switch; then place wheel Tilt/Level joystick in the LEVEL position.

VII. Operator observes hydraulic fluid pushing from a broken hydraulic line or fitting.

VI. Hydraulic lines to link arm cylinder are ruptured. This type of failure will prevent wheel from being returned to the level position with the emergency re-level system explained in I.B. above or with the joy stick. The operator must push the emergency STOP mushroom switch to place the wheel in free wheel and hold the boom down joy stick in the DOWN position.

CAUTION: AFTER OPENING LIFT CYLINDER OVERRIDE VALVE, BOOM WILL NOT STAY IN THE AIR UNTIL VALVE HAS BEEN CLOSED.

V. If power is interrupted from loss of power at source or by pushing EMERGENCY STOP mushroom switch, the wheel will immediately free wheel for several seconds.

IV. After stopping wheel ride operator chooses to unload ride. It electrical power has not been interrupted lower boom by moving joy stick toward bottom of operators console. If electrical power has been interrupted lower boom by opening lift cylinder valve override handle located inboard of the cooling fan.

III. After stopping wheel ride operator chooses to unload ride. hydraulic system is tripped allowing wheel to rotate in a free wheel mode until it stops. As the wheel slows to below 20 rpm, the wheel will automatically level. To operate ride after using emergency stop button the EMERGENCY STOP button must be pulled up then the breaker must be reset to its original position.

SPECIFICATIONS

	TOTAL POWER REQUIRED	89 KW
	POWERED BY	50 hp, 1750 rpm electric motor
	MAXIMUM AMP DRAW	225 amps
	VOLTAGE	220 volt, 3 phase with ground
	ELECTRICAL LEAD WIRES	Standard: Five individual wires with type M insulation. Power wires are 02 size & ground is 00. Optional: single cable that contains power leads & ground. Type M insulation.
	LIGHTING	Mini Turbo lights 60V 4w bulbs Turbo lights 110V 10w bulbs Console spotlights 12V 35w bulbs Outer skin spotlights 24V 35w bulbs Panel lights 110V 11w bulbs Floodlights 110V 500w quartz halogen bulbs Rotating beacon 110V rotational motor 12V 30w bulbs
	CAPACITY	3+ adults or children with combined weight of 5800 lbs.
	MAXIMUM OPERATING HEIGHT	37 feet
	SPACE REQUIRED	55 feet by 40 feet
	TRAILER LENGTH	28 feet
	RIDE SPEED	22.5 rpm max. 20.0 rpm min.
	PASSENGER MINIMUM HEIGHT REQUIREMENT	48 inches

* CAUTION: Failure to supply an adequate ground to the frame can cause serious electric shock. Proper grounding prevents the metal parts of the Zendar from being energized with high voltage in the event of a short circuit. Another means of grounding is with a ground rod. Check local regulations for ground rod requirements and specifications.

INTRODUCTION

This manual is intended to be used as a general guide for the operation and maintenance of your ride. Darton Industries, Inc. is constantly striving to improve performance, efficiency and safety; therefore, certain improvements may not be reflected in the text of the manual. Any major revisions or additions to the manual will be sent to you free of charge. Specially engineered features purchased for individual rides may not be incorporated in this manual.

MANUFACTURER'S LIMITED WARRANTY

Darton Industries, Inc. warrants that purchased property is free from all defects in material and workmanship at the date of delivery and for one year thereafter. Darton Industries, Inc. does not warrant that purchased property will meet or exceed Federal, state and local design criteria or electrical codes. Darton Industries, Inc.'s liability is hereby limited to the repair or replacement of any equipment, accessory or part which is defective due to material failure or workmanship. The cost of returning defective parts to Darton Industries, Inc. and the cost of transportation of repaired or replaced parts to purchaser shall be born by purchaser. Darton Industries, Inc. shall not be liable for down time or loss of operating revenue or any other commercial consequential damages. Losses resulting from improper maintenance or failure to observe Darton Industries, Inc.'s operating instructions are expressly excluded from this warranty. Purchaser hereby acknowledges receipt of current operating, maintenance and erection instructions, a copy of which is attached to this agreement and made a part hereof.

It is expressly understood between Darton Industries, Inc. and purchaser that all warranty is void and Darton Industries, Inc. disclaims any and all liability or responsibility for failure, loss or damage if device is assembled, maintained or operated other than as recommended in the Manual provided with each device or is loaded or operated in excess of the operator's operating criteria set out in the appropriate manual.

THIS WARRANTY, AND THE OBLIGATIONS AND LIABILITIES OF DARTON INDUSTRIES, INC. HEREUNDER ARE IN LIEU OF ALL OTHER WARRANTIES, GUARANTEES, CONDITIONS OR LIABILITIES, EXPRESSED OR IMPLIED, INCLUDING WARRANTIES OF MERCHANTABILITY AND FITNESS FOR A PARTICULAR PURPOSE AND SHALL NOT BE EXTENDED, ALTERED OR VARIED EXCEPT BY WRITTEN INSTRUMENT SIGNED BY DARTON INDUSTRIES, INC. AND PURCHASER.