

MFG: FAJUME SADECA  
RIDE: WACKY WORM



Fajume S.A. de C.V.  
Prolongación calle arce # 2320 P.O. BOX 868  
col. Flor Blanca , San Salvador, El Salvador C.A.  
Tel. (503) 260-7999  
Fax (503) 260-6682  
E-mail [fajume@salnet.net](mailto:fajume@salnet.net)

---

SET UP GUIDE FOR  
WACKY WORM  
TRAILER MOUNTED MODEL

SET UP INSTRUCTIONS  
AND  
RECOMMENDATIONS.

1999

# SET UP INSTRUCTIONS FOR WACKY WORM TRAILER M.

## 1. BASE ASSEMBLY.

Before beginning to assemble the device, be sure to secure an area of approximately 42 ft. By 92 ft. ( 12.8 mt. By 28 mt. ). We recommend that the terrain be as flat as possible. To make sure you have the correct space, the next picture will show you the measurements you need to get a perfect position.

MEASURES TO GET THE RIGHT POSITION

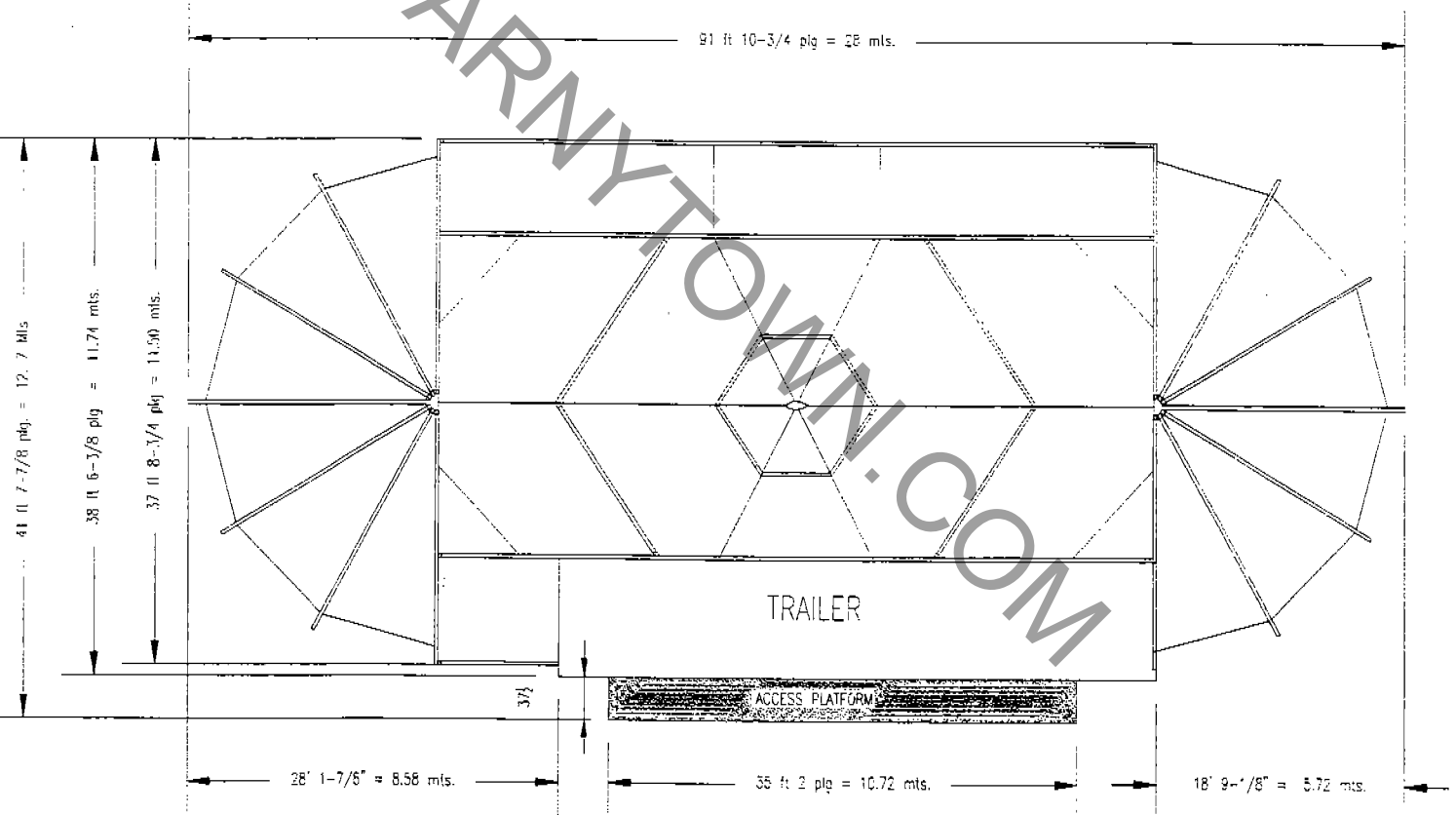

Once you have the right position , the next step is level the trailer to the right position, let the air go out of the air bags, pulling the pin in the back left side on the joins of the trailer. ( Fig. 1).

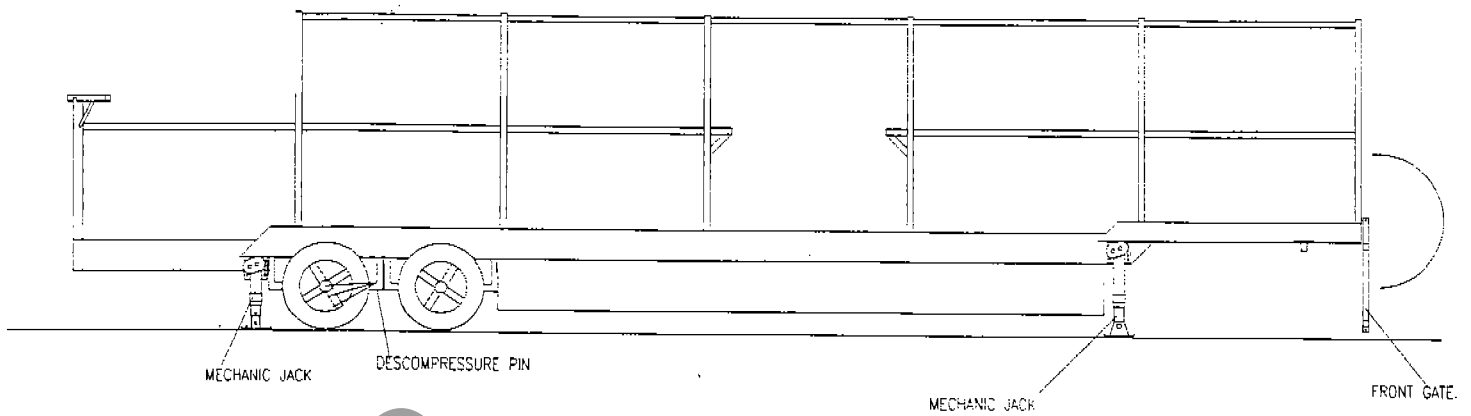

FIG. 1

When you finish, all the trailer will rest on the mechanical supports, then you unload the base according to the Fig. 2.

BASE NUMERATION FOR WACKY WORM TRAILER MOUNTED

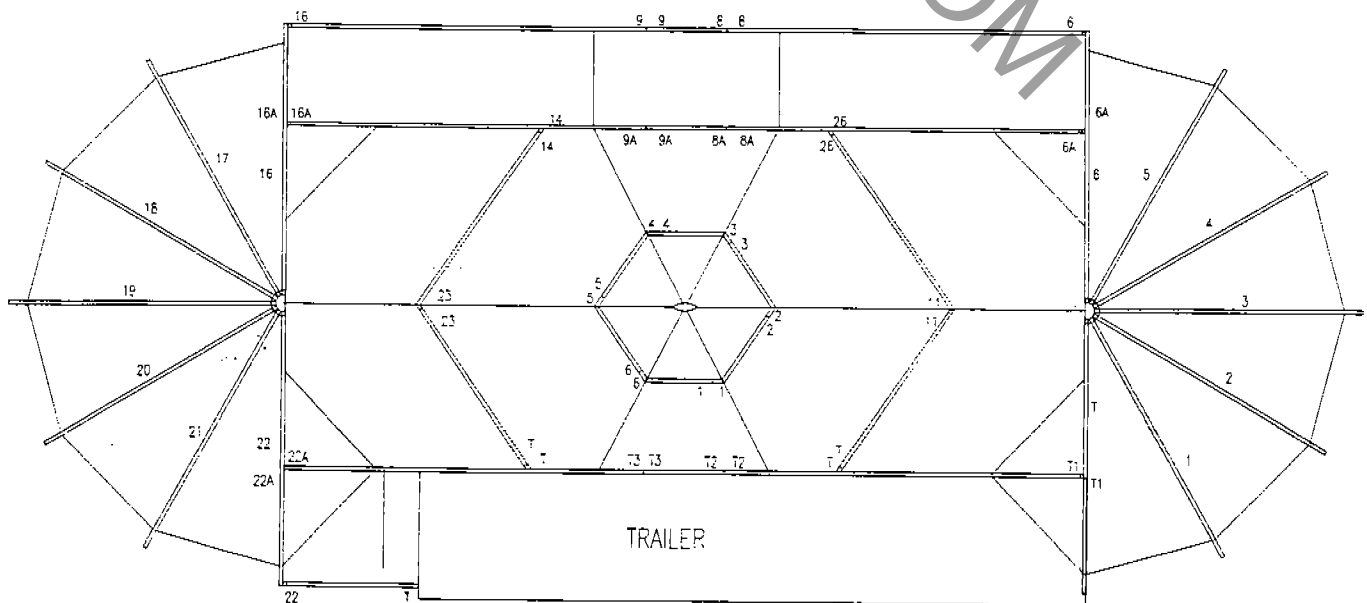

FIG. 2

In Fig. 3 you can see the sujection arms on the base and trailer. They help to make the base stronger. You put it in the up position for travel.

SUJECTION ARMS BASE - TRAILER.

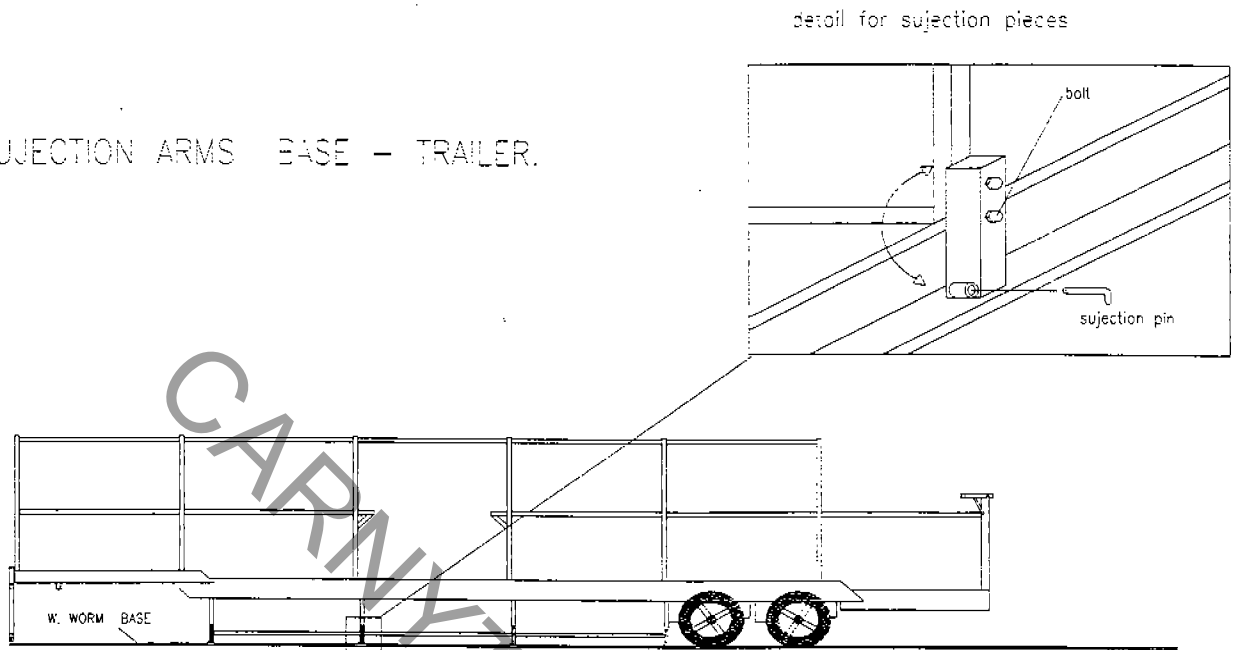
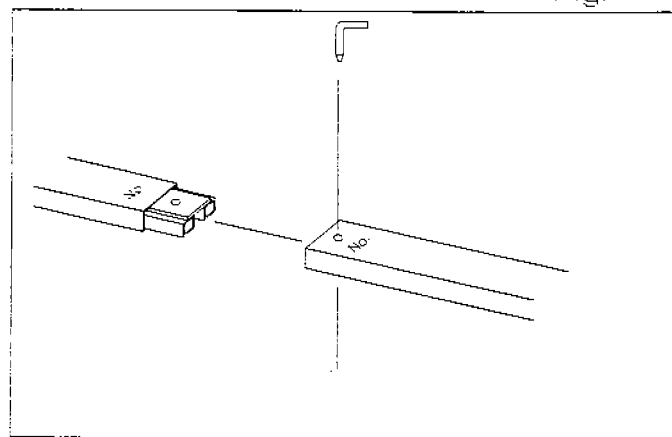

FIG. 3

Is important to notice that every piece of the base that goes together has the same number at the end, so is impossible to put it together if they don't have the same number. This is illustrated in Fig.4.



When you end assembling the base, you have to check the tensors that goes all the way from one side to another, be in a straight line like Fig. 5.

### CENTRAL BASE TENSORS

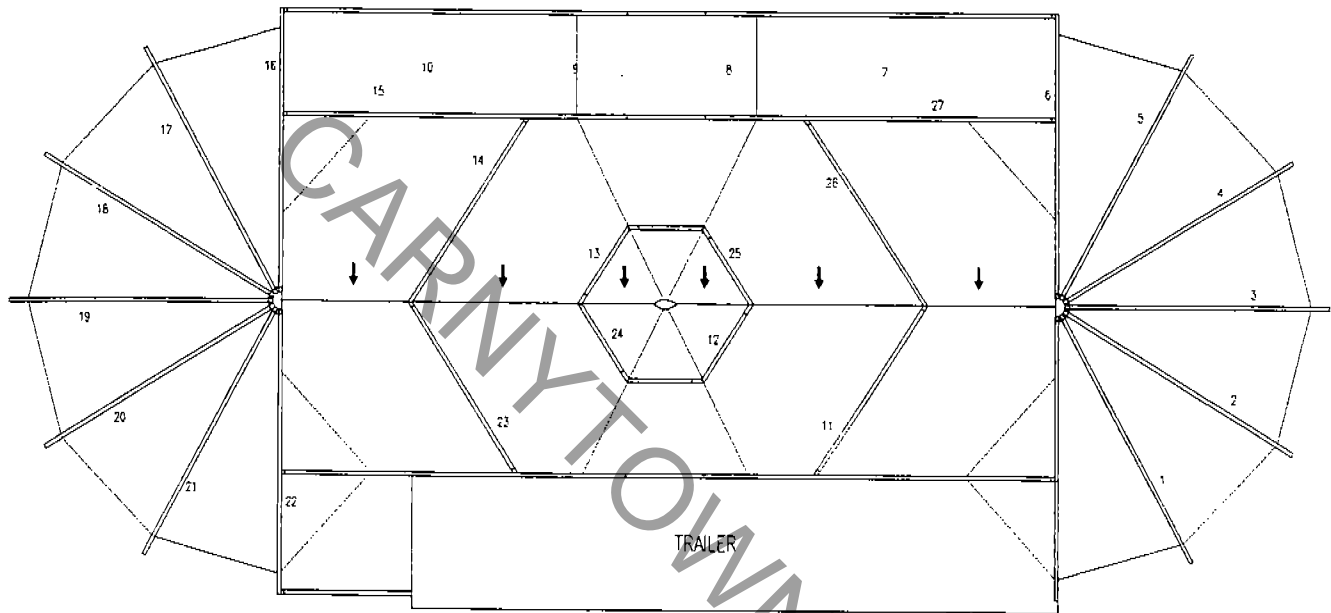

↓ BASE TENSORS THAT HAS TO BE IN A STRAIGHT LINE

FIG. 5

Is important that the base be as straight as possible, so it will make it easy to set up the ride. For a safety measurement ( if you think is necessary ) you can measure diagonal, just like Fig. 6, to confirm the measurement 66 ft. 2-9/32 plg. ( 20.17 mt. ).

Is to mention that the tensor are not the same size all of them. Using the wrong tensor will make the base never be parallel. Be sure to use the right tensor in the right place. When you finish it, you start leveling the base, this is the most important step in the assemble, because here depends that the rest assemble easy. A bad leveling will cost that the tracks and tension guides will not assemble easy. It is recommended that you use a big box level or you can use graduated bar ( teodolit style ).

# DIAGONAL MEASSUREMENT

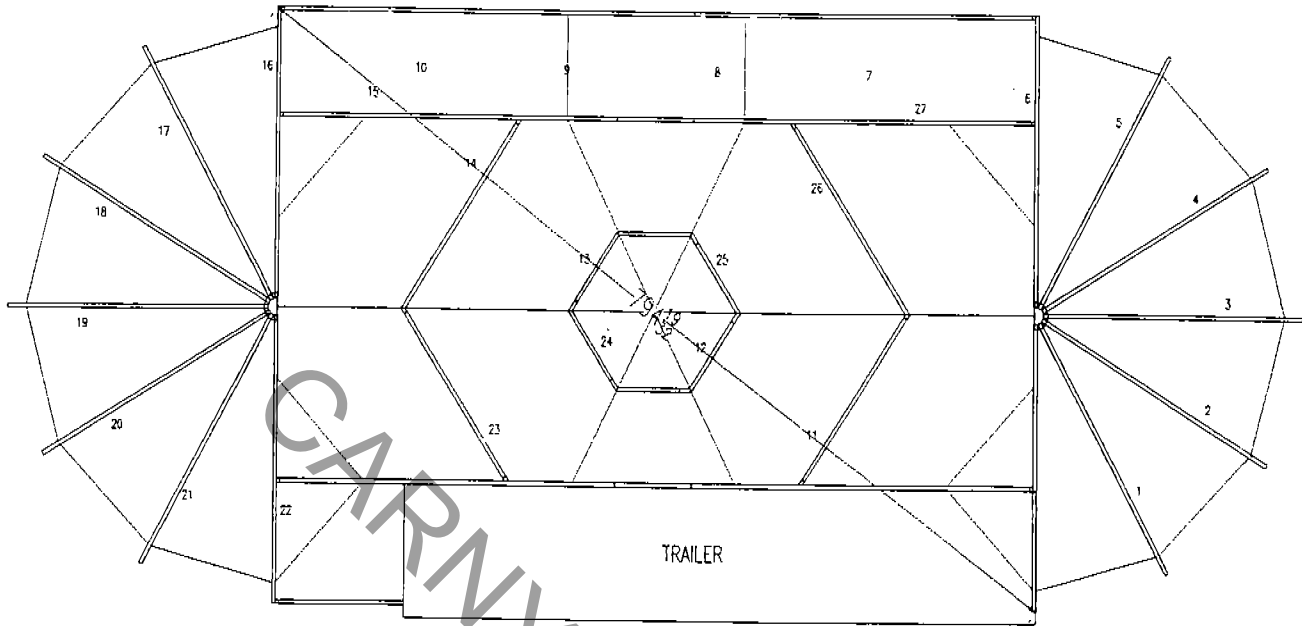
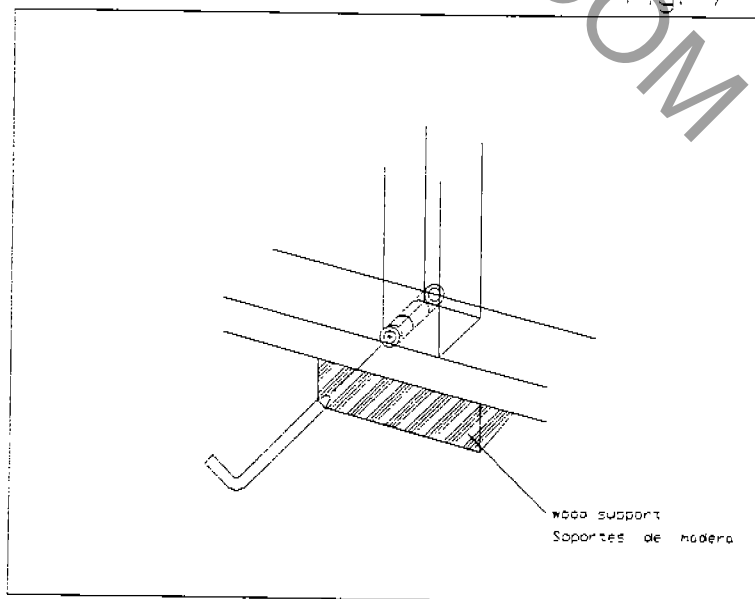

FIG. 6

It's recommended that the wood supports be used under base joints as well as the places where the jack stands are placed, as it is shown in Fig. 7.



## 2. TRACK ASSEMBLY.

Prior to track assembly, it's recommended that the jack stands are placed as in Fig. 8.

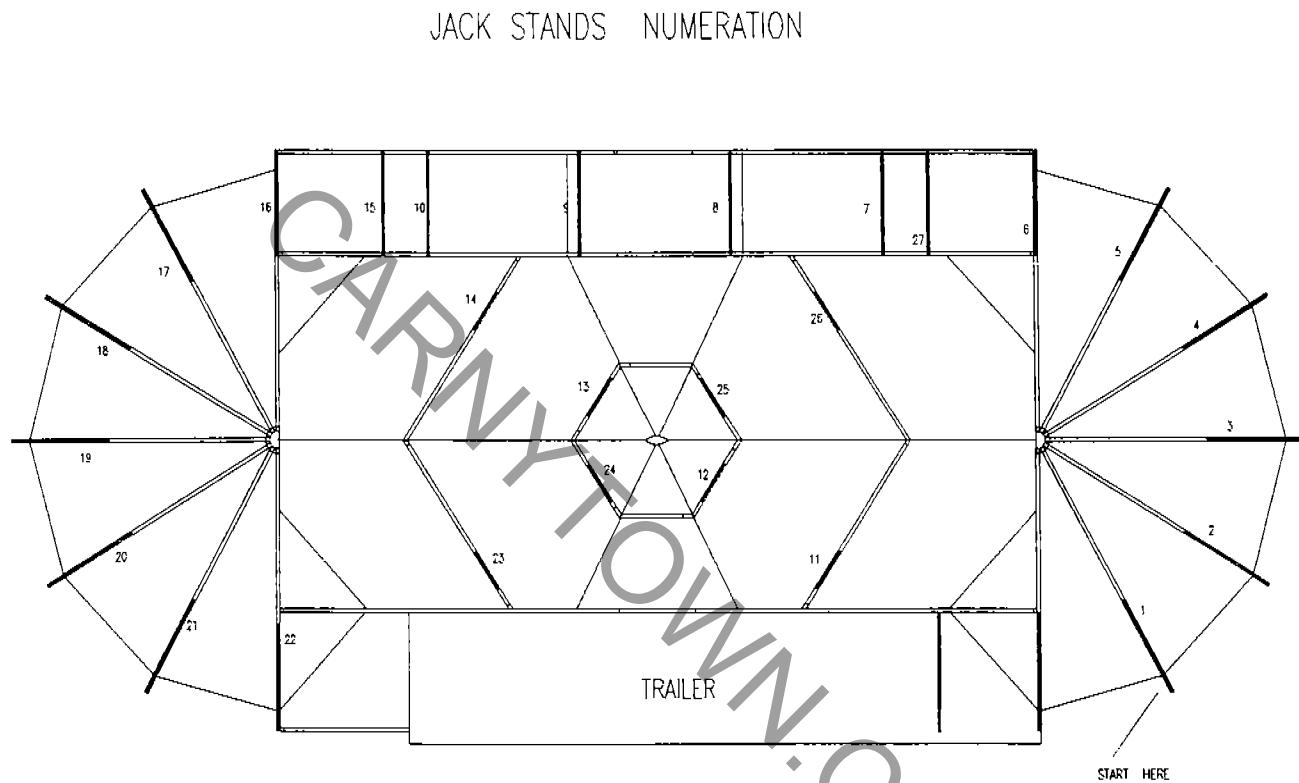
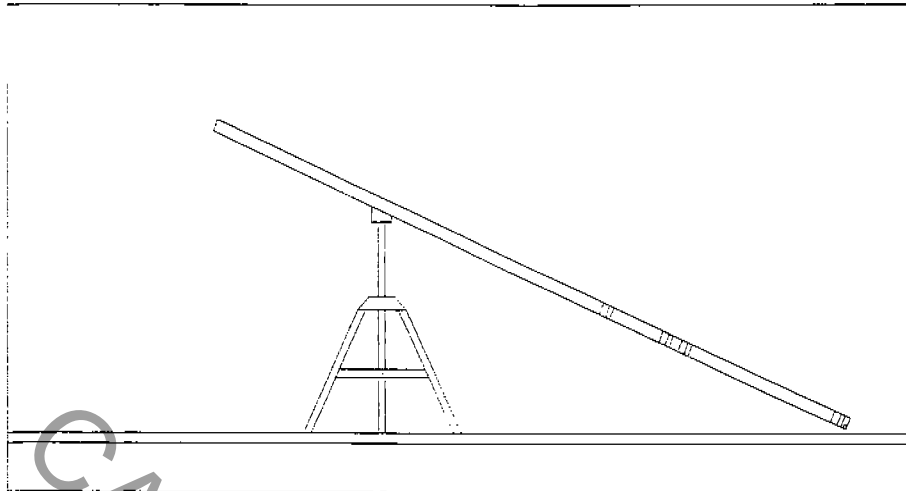

FIG 8

Also remember these jack stands never has to rest completely horizontally as this damage the jack stand or the base by the piece that is welded in the base, and which is the support. The jack stand should be tilted slightly using a block or lift, like Fig. 9, that make it easy to put the track on, but it should not be left horizontal.

Fig. 9



The track assembly instructions are as follow:  
With the jack stand in the position like Fig. 9 , and the winch up, put the lips in the jackstand ears like Fig 10., you can pull it up all together

Fig.10

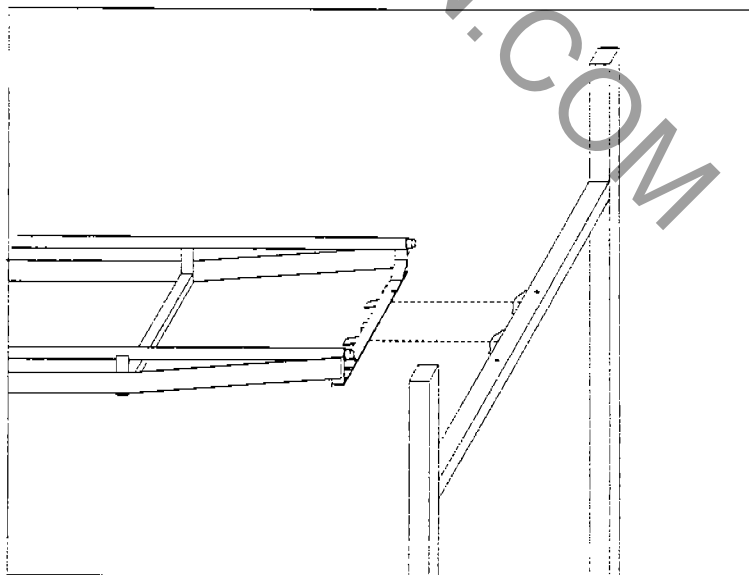

Once the lips are in the rings, stand up the jack stand with the track and assemble the track with the one you've already stand up before like Fig. 11.

Fig. 11

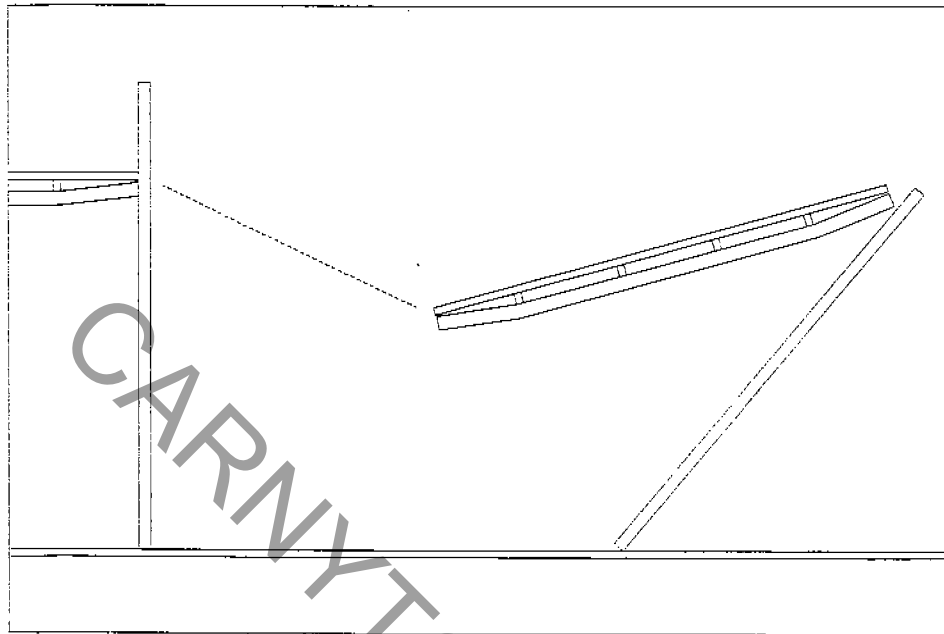

The tracks that you stand up have to be hook with a pin, wedge and r-key as shown in Fig. 12. It is recommended that the jack stand that has a flower on, you standed up with the flower on it, so you don't have to put it in higher.

Fig. 12

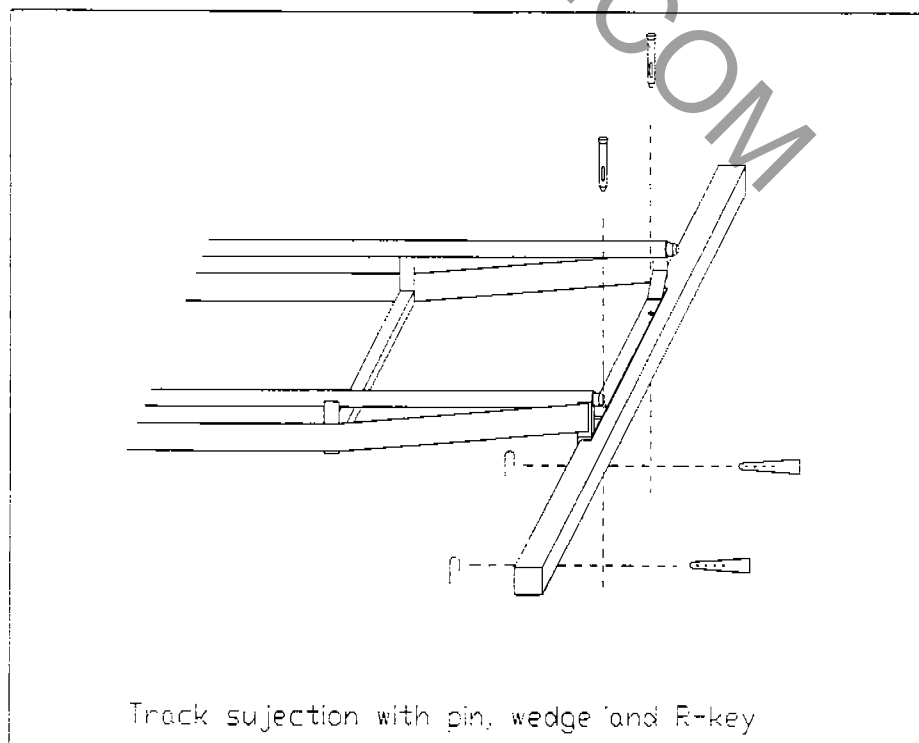

The rails order it is show in Fig. 13

### TRACK NUMERATION

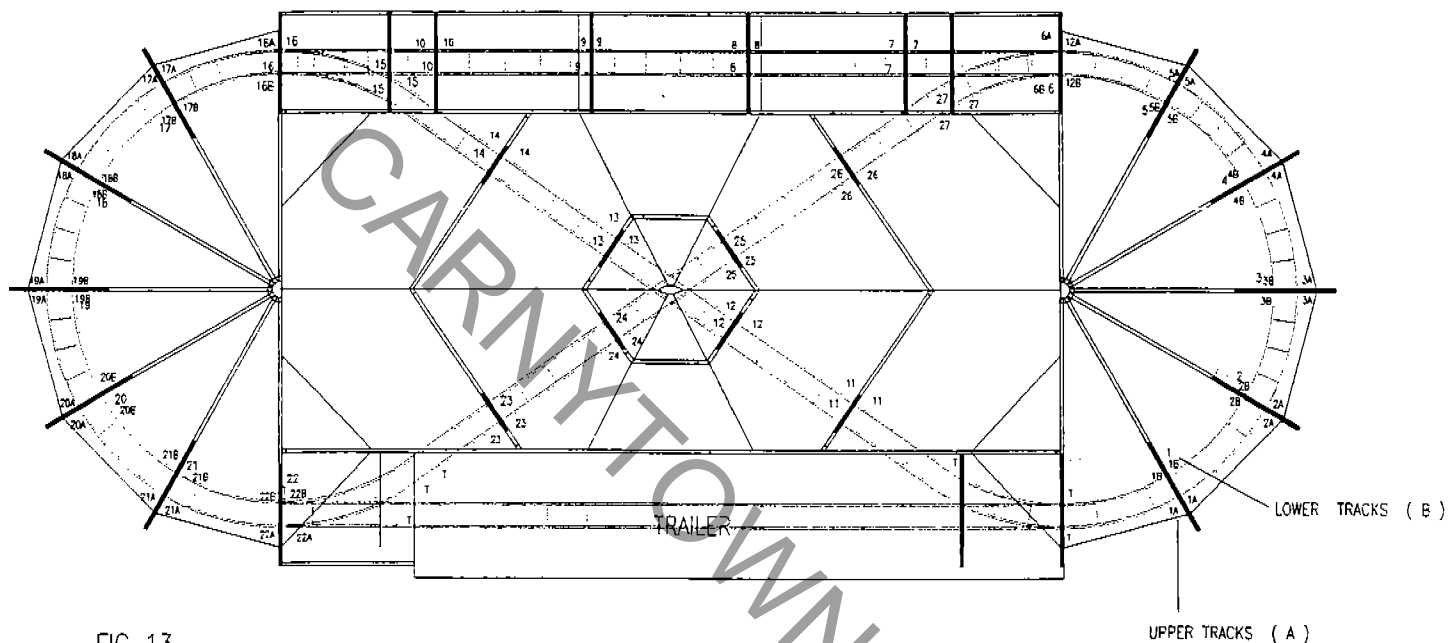

FIG 13

### 3. JACK STAND TENSORS.

When you put the first jack stand with the track, it is important to put the jack stand tensors. They are the once to give strength to the structure. Do not forget this step, it can be dangerous. Check this step in the part that you put the hill jack stands. Be careful because could be dangerous if you forget this step.

For the mid section the tensors help to give strenght just like Fig. 14

Fig. 14

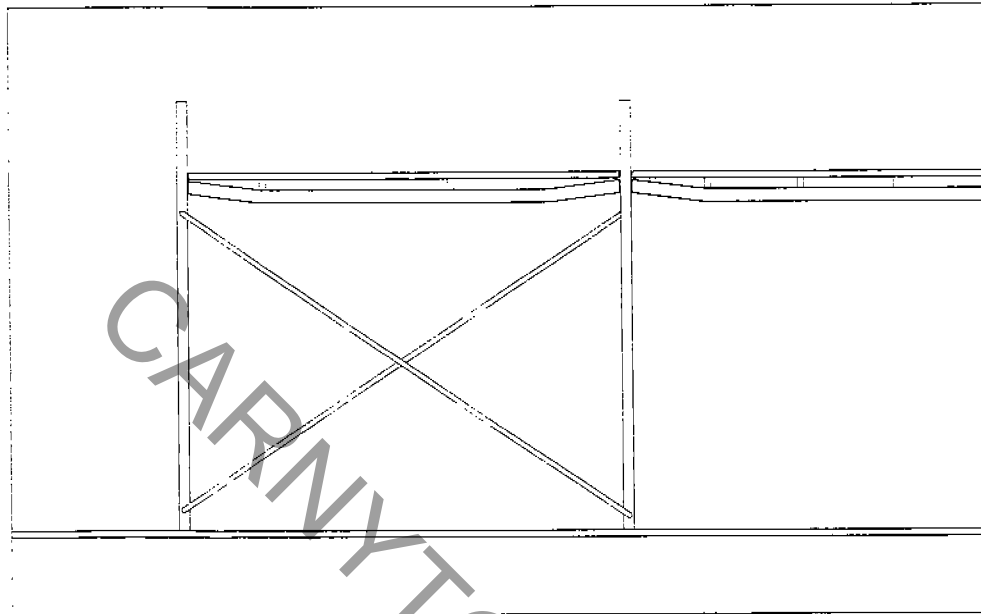

#### 4. STATION SUPPORT AND EMERGENCY PLATFORM SUPPORT.

After the entire structure has been raised, proceed to place the station support wich hold up the loading and operator platforms. These are shown in Fig. 15. These also are numbered at each end to coincide with their respective jack stand.

#### 5. BRAKES.

The Wacky Worm brakes are operated by neumatic system ( air cylinders ) . They are 2 in the station and 1 in the down hill. They have a safety system of tensors and regulators that keep closed the brakes blades. This help to slow down with less air pressure ( in the station or downhill brakes )

The Fig. 16 and 17 will show you the brakes with their air cylinder and the regulators.

EMERGENCY PLATFORM  
SUPPORTS

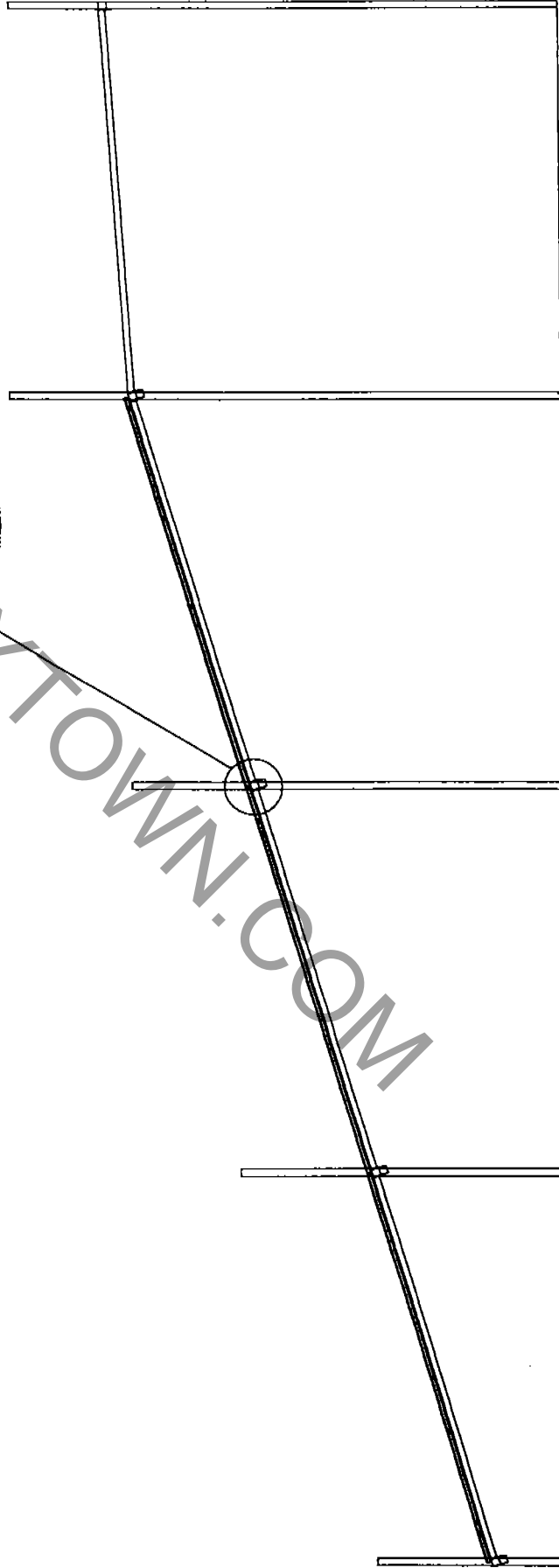
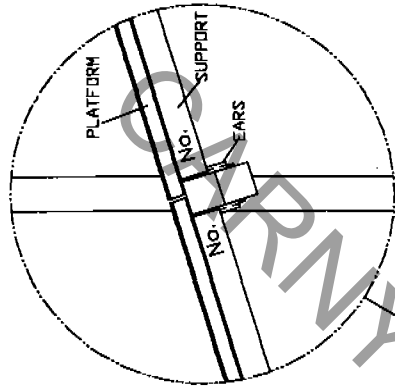

STAND 6

STAND 7

STAND 8

STAND 9

STAND 10

FIG. 15

# BRAKE STATION

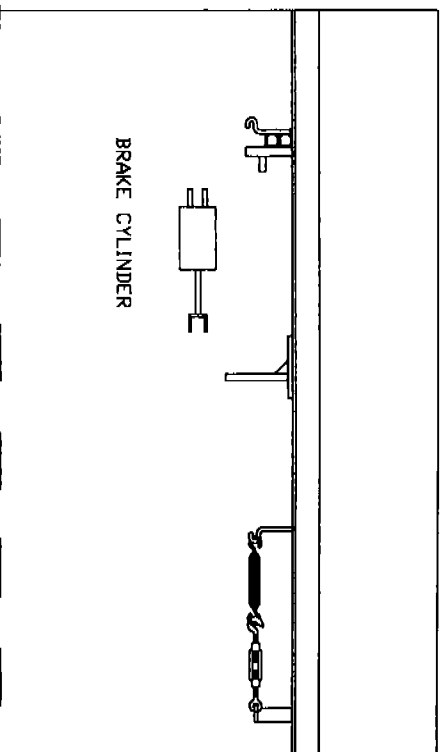
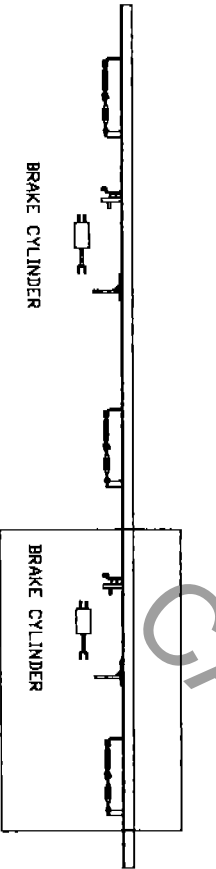
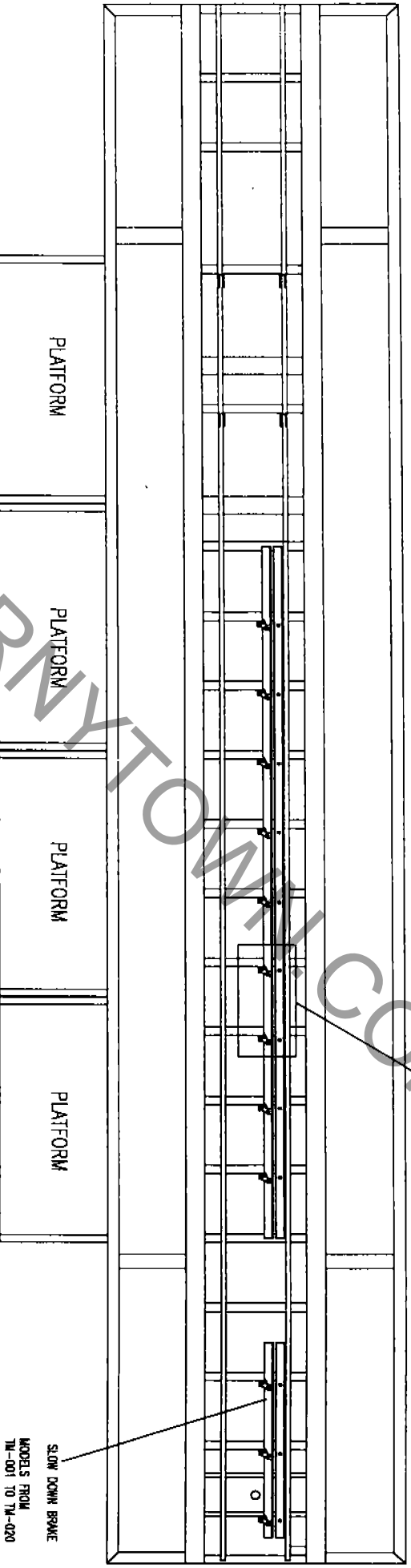
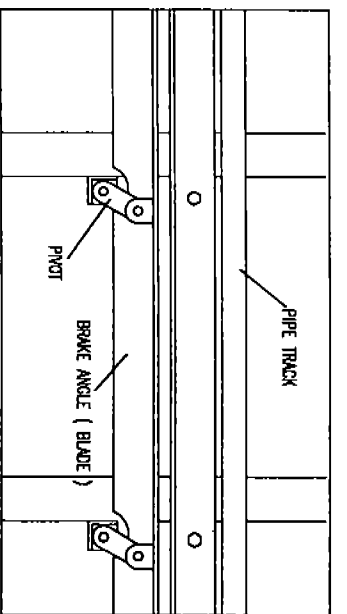

FIG. 16

# DOWN HILL BRAKE

CAUTION

This brake must be used all the time for their own people safety and the ride too

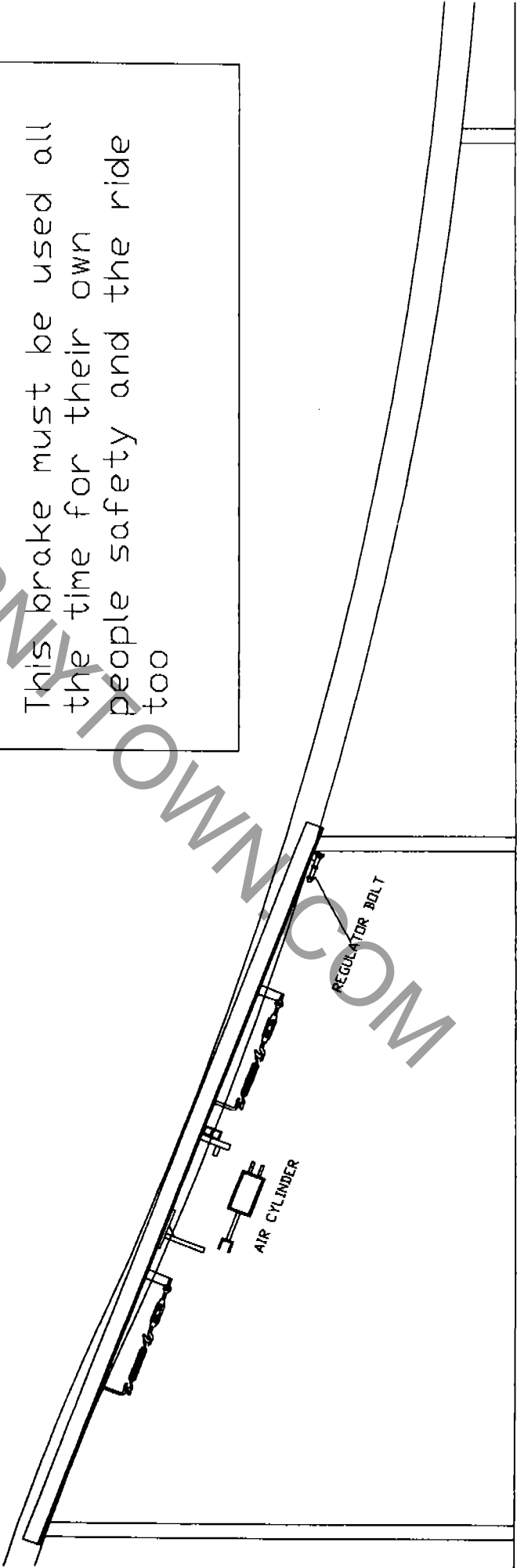

FIG. 17

LAPBAR ACTIVATORS

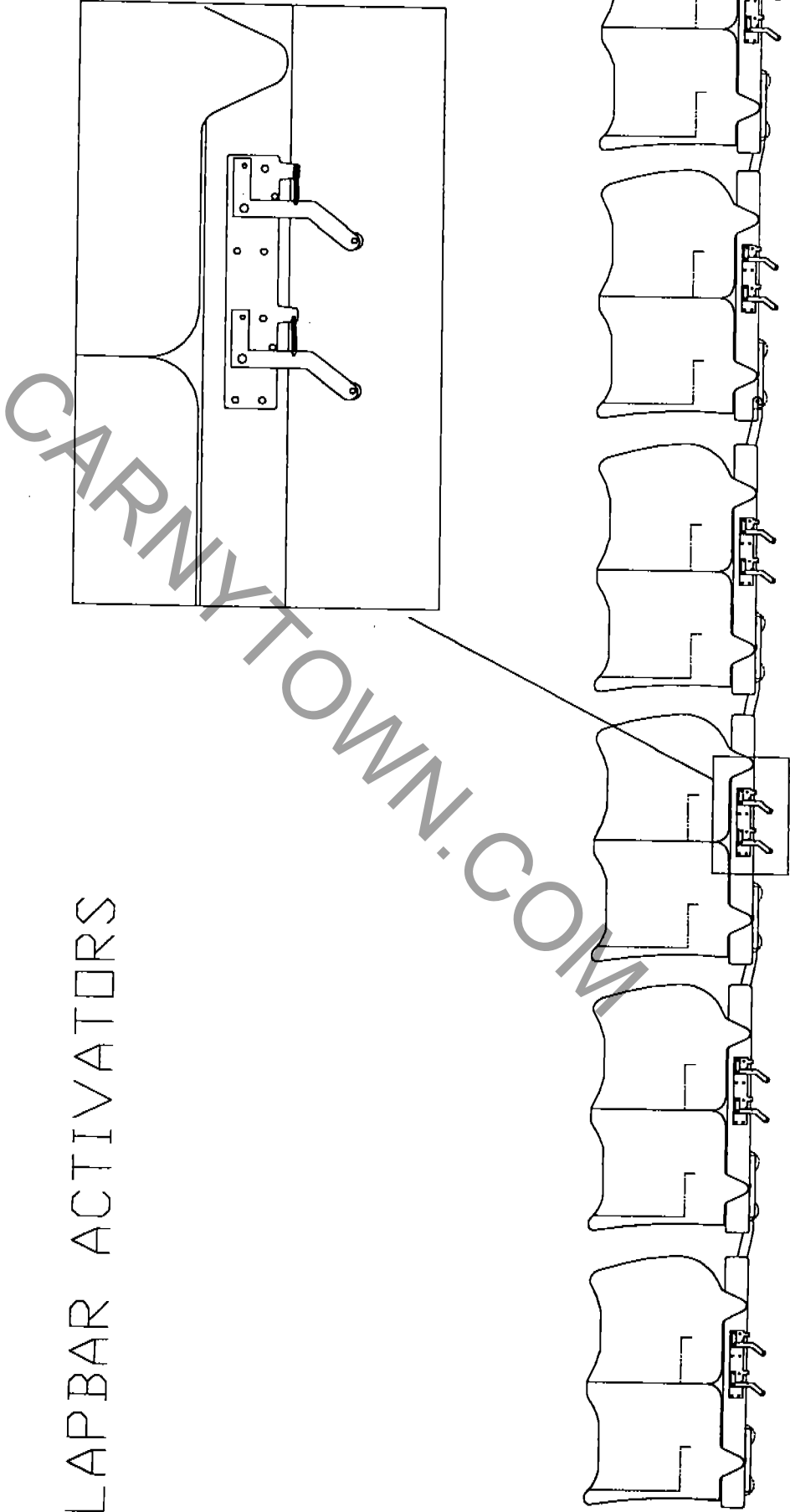

FIG. 18

# LAPBAR RELEASE MECHANISM

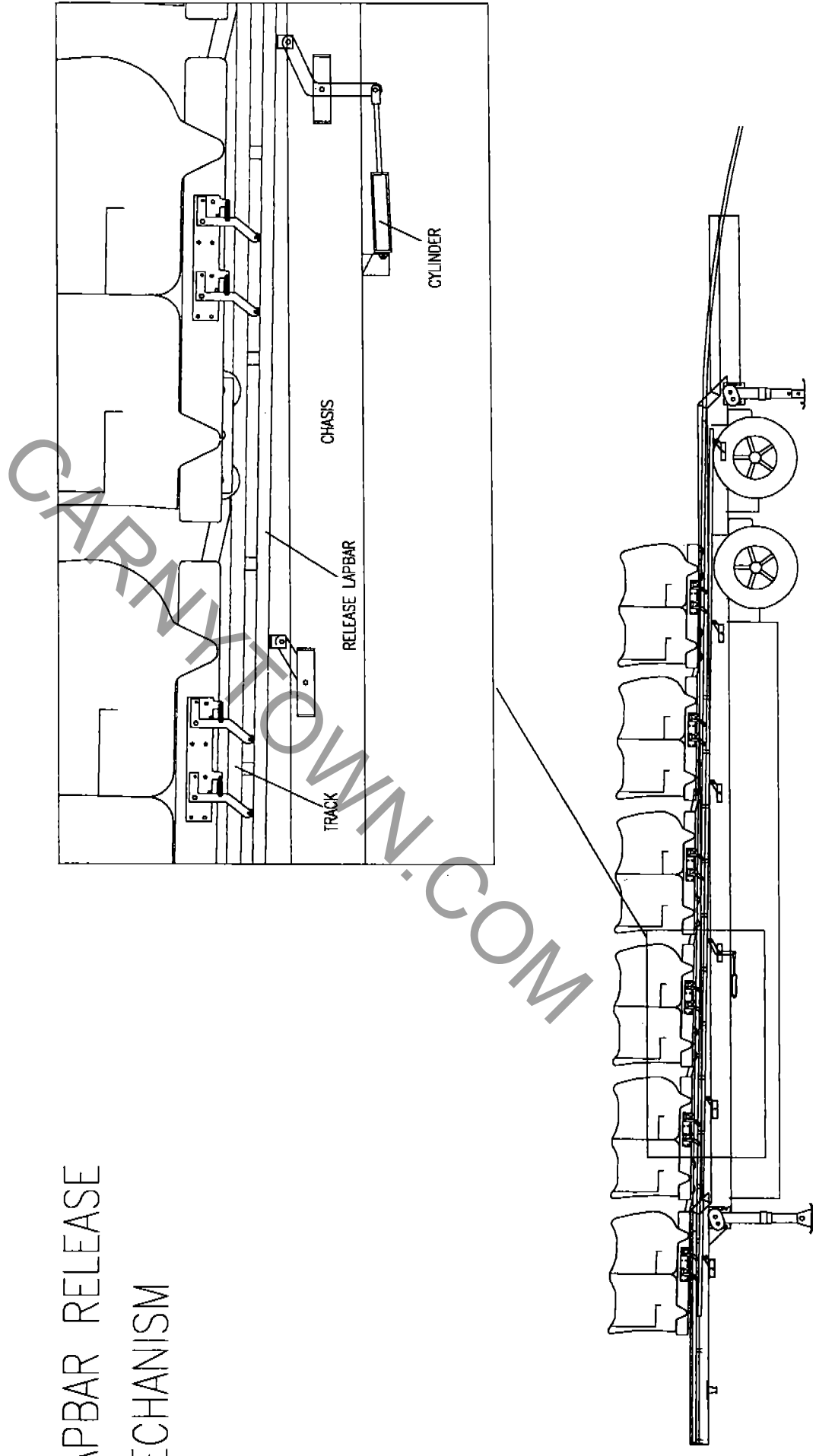

FIG. 19

## 6. CARS SAFETY LAPBARS AND ACTIVATOR.

Each car is equipped with a security system that is activated manually or with the lapbar activator. These pieces are shown in Fig. 18.

The trigger system is activated with a neumatic cylinder, the pivots are on the chasis and are shown in Fig. 19.

## 7. CONTROLS

The Wacky Worm control box has the next function illustrated in Fig. 20

Fig. 20

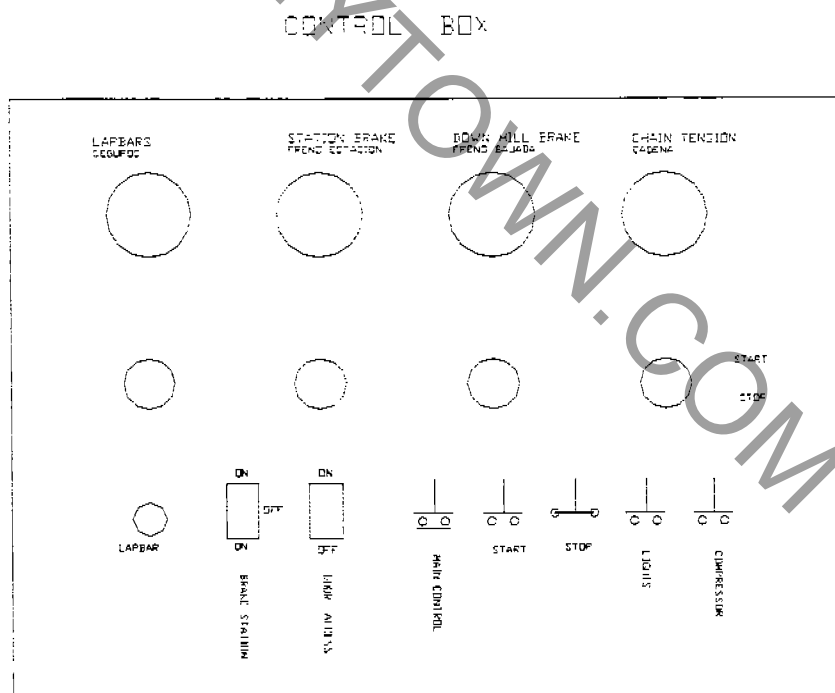

## 8. DECORATION PANELS.

These are the decoration panels, they go as you see in Fig. 21. They go with a number in each piece according with the number put it on the main platform.

DECORATION PANELS

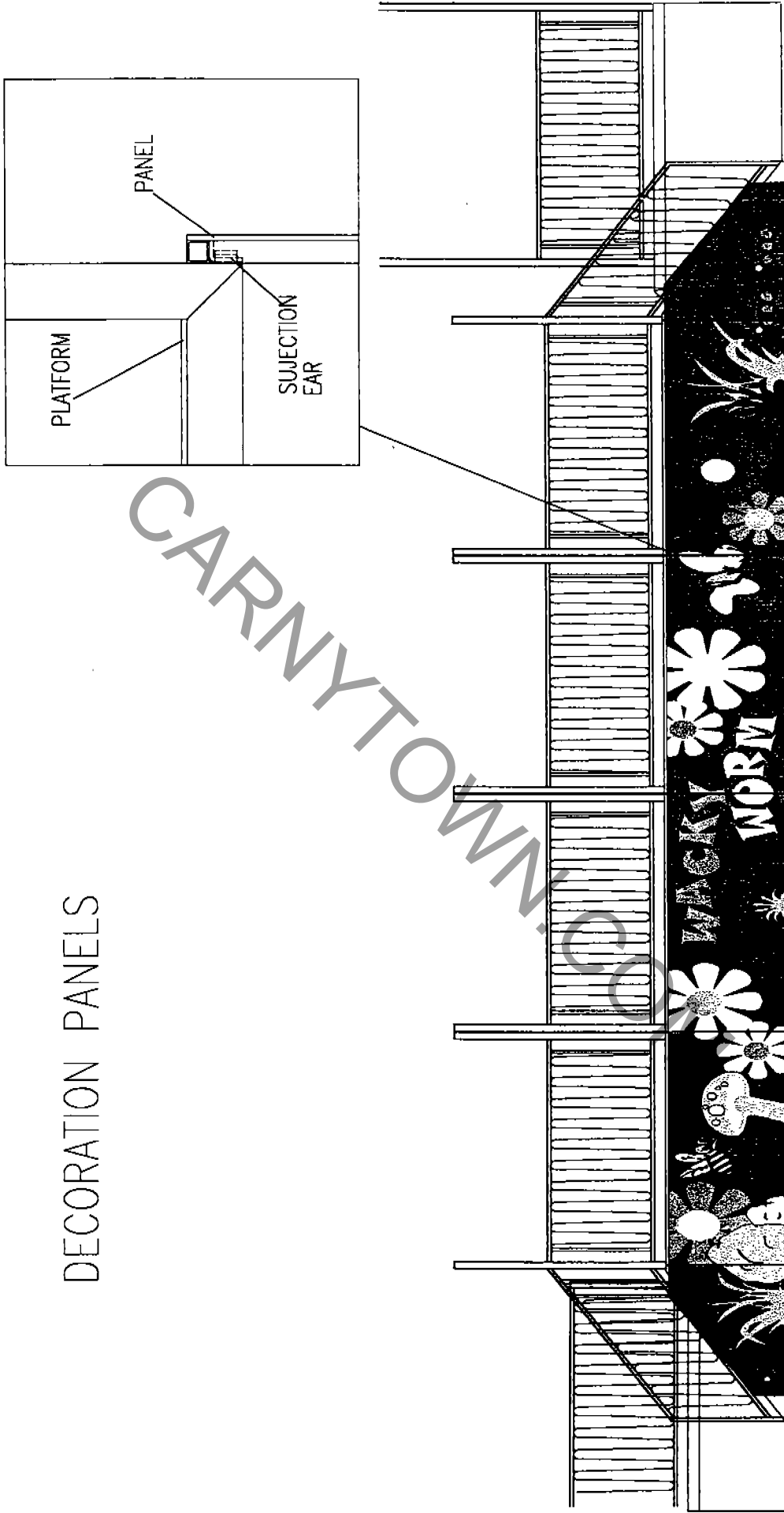

FIG. 21

## 9. ELECTRIC DIAGRAMS.

The Wacky Worm has an interconnected system starting with the main power box. See Fig 22 y 23.

For convenience, each extension has the jack stand number on each terminal outlet, making it easy to look up once they are organized by number.

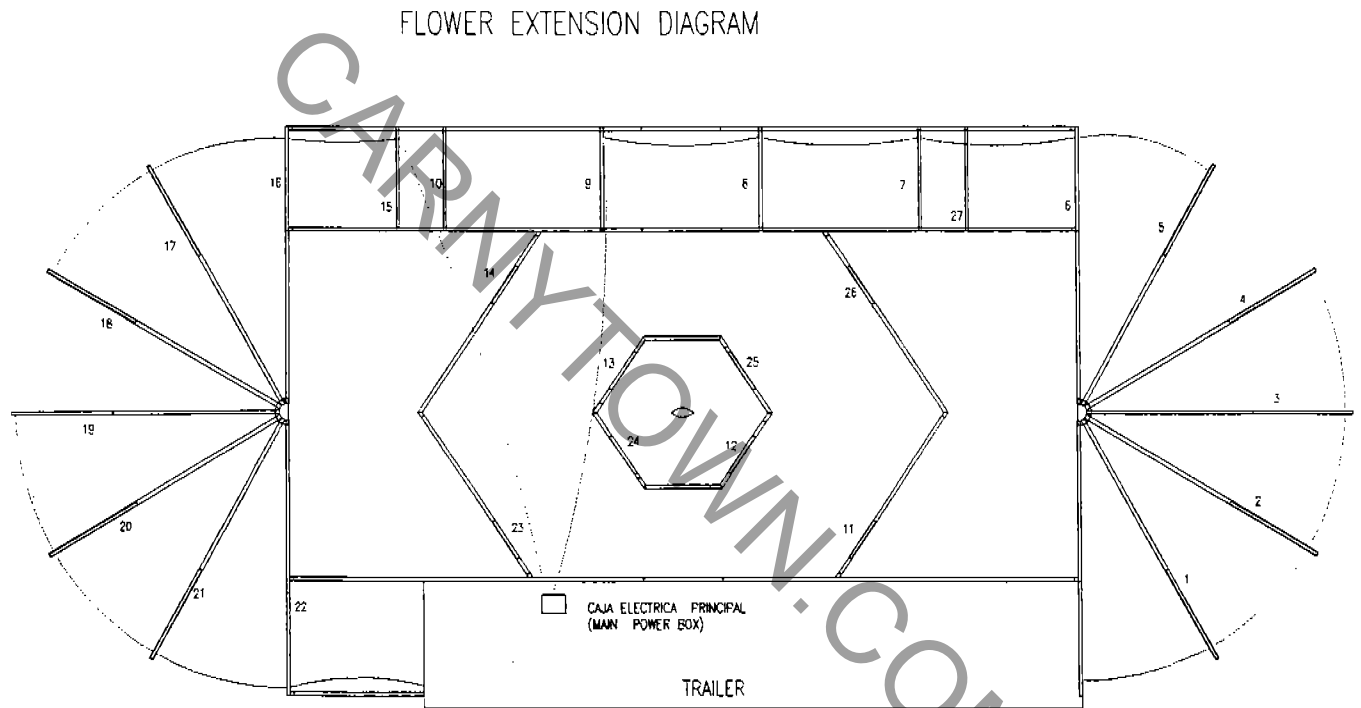

FIG. 22

DAYSIES EXTENSION DIAGRAM

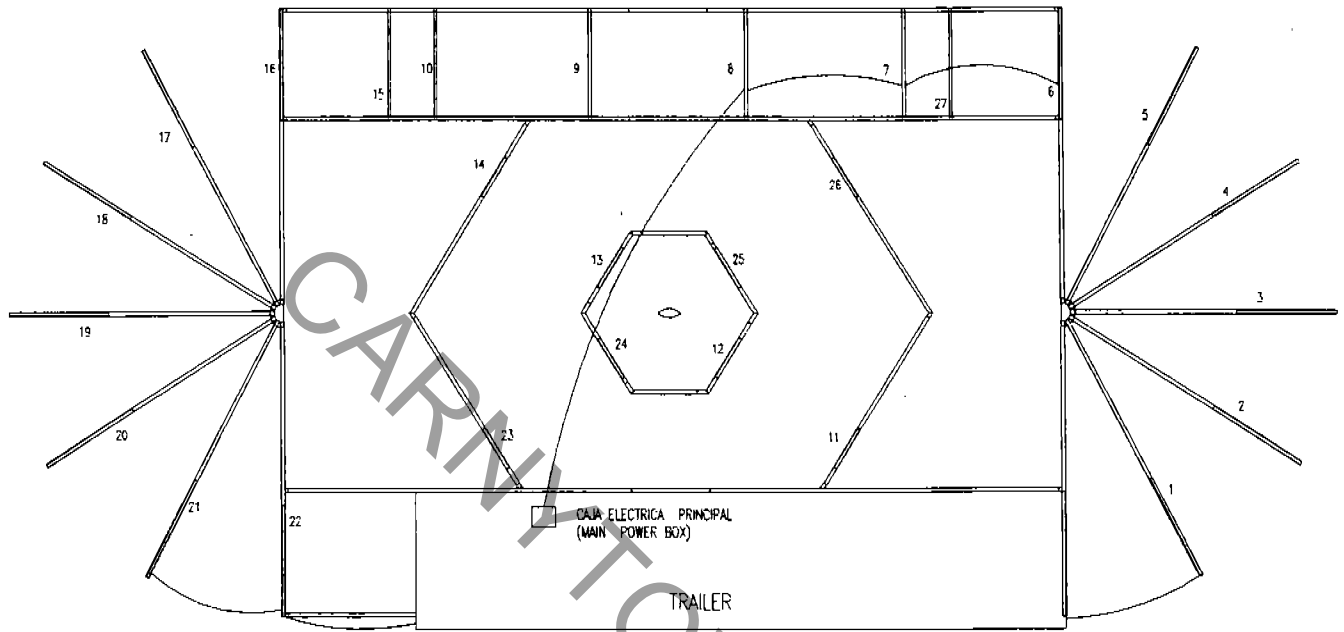

FIG. 23

## RECOMMENDATIONS

1. With the air pressure of the brakes, the pressure will never be less than 100 pounds, and the blade brakes never have to be completely closed with full air pressure when the train goes on the station in order to avoid hit the cars and damage the people for quick stop.

The pressure for the lapbars has to be around 70 and 80 pounds for best results.

The pressure for the cylinder for the tensor of the chain ( this no applied for roller chain ) has to be approximately 15 – 35 pounds. The pressure for the cylinder of the brake of down hill depends of the amount of people inside the train. If is full, you use more pressure, and if is empty you use less pressure

Is recommended to use this guide:

| qty people | Presión    |
|------------|------------|
| 8 - 10     | 25 lbs.    |
| 11-20      | 40-50 lbs. |
| 21-30      | 50-70 lbs. |

Note: This is according to changes of the machine and atmospheric conditions like humidity.

We strongly recommend that the space between the blades brake on the down hill do not exceed ¼" inch .

2. For the compressor, never turn off the switch, when the machine is running. It has to be in the AUTO position, because automatically turns off, and it depends of the needed of pressure. Normally starts at 90 pounds of pressure but you can increase if you think is not enough

3. Check the air cylinder connections in the station brake and the down hill at least once a day in order to avoid problems during running.

4. Is recommended that when two persons are in a car ( one child and one adult ) the child must be seated in the left, and the adult in the right because of the centrifugal force.

5. It has to be sure that all pins are secure with the wedge and r- keys. You must to be careful with this and check every day before start.

6. **The chain has to be very lubricated in order to avoid friction with the pieces.** This is very important to preserve the propulsion mechanism . ( no applied for roller chain ).

7. Check every week the oil on the gear box and the hydrodynamic joint. For gear box you can use 90 or 140 oil and for the hydrodynamic joint use ATF for transmission..

8. If the machine is put in a place that is not flat, is recommended that you check the level and the wood support in each point of the base specially in the rainy season.

## **OPERATION INSTRUCTIONS.**

The Wacky worm operations are very simple, but is important that the operator knows the functions very well.

Before you start:

- Check the voltage in the control box, and make sure that three phases are present.
- Check that the pins are right with the wedge and the R-key
- Check the wood support on the base. They have to be firm.
- Check that the cars are joined right with the emergency cables and pins.
- Start the motor and the chain checking if they are rotating in the right way.
- Check that the way tracks are free of obstacles before you start the ride.
- Is recommended that before you put people inside the cars, you run the machine empty ( 3 or 4 times ).
- During the first running you check the brakes and the lapbars.
- The operator never has to leave the control of the ride, mofre important if you have people on it. He has to be carefull and pay attention of noises on the tracks, cars, motor, etc.

The Wacky Worm is first loaded with 36 children or 24 adults. Then the entrance and exit are closed. No person is allowed to stay on platforms during operation. The operator then checks that all lapbars are closed while he takes the tickets. When all lapbars are locked, the chain can be started and the operator must check that track is free from obstacles. The operator must then release the brake and hold it open until the train leaves the station.

The brake in the loading station is spring loaded, so it will automatically bring the train to a complete stop after one running cycle if there is no operator in control box or the lever.

As the train enters the loading station from its first ride around the track, it has to be slowed down so it gets to the lift with aproximately the same speed of the chain. To do this, the operator has to release the loading station brake halfway open. Tuis is very important to the like of the chain.

At the end of determined time of the ride, the operator has to actievate the lapbar unlocking device until the train has stopped completely.

## **DAILY INSPECTIONS.**

- Check that all wires are connected right.
- Check joint points, pins, security cables on the cars.
- Check that the lapbars work properly.
- Check the nylon wheels turn right.
- Check the brakes.
- Check if the chain is tight properly.
- Check the lights.

## WEEKLY INSPECTIONS.

- Check the conditions of joint point in the tracks and the base .
- Check carefully if you have corrosion in some of the pieces, so you can act immediatly applying primer or grease.
- Check the condition of the axles, bearings, and wheels in the cars.
- Check the grease on them .
- Check the condition of the blade brake in the cars.
- Check the oil level in the gear box..
- Check the oil level in the hydrodinamic joint. .
- Check the condition of the electrical connections

## WEEKLY LUBRICATIONS.

- Grease the round bearing and the flat ones of the axle .
- Grease the bearing on the nylon wheel ( if they are not sealed ).
- Grease the chain in order to avoid dryness.
- Grease bearings of pinions .
- Grease pivots on the brakes.

## WACKY WORM LOADING.

Everything is shown in the Fig. next to this page. It is recommended that when you unload the first time check how they came , so it will make it easy to put everything back in a right place.

Pay attention to the following items:

### 1. Jack Stands load.

The way to load the jack stand have to follow the next diagram. You have to put in the same order taking care to place the jack stand signed by an arrow which means that you have to put them inside of the free space of the main jack stand. Do not over load or put next these jacks stand because you can increase the height of the group. You have to use two blets at least to tight the group.

CARNYTTOWN.COM

WAY TO LOAD THE JACK STANDS

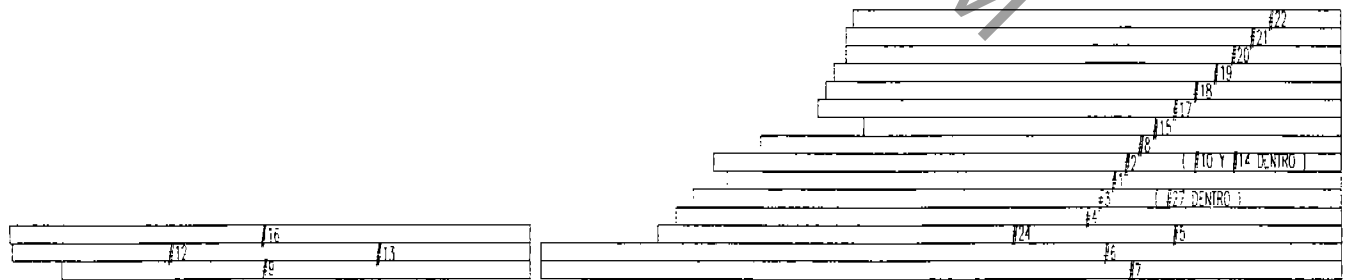

CARNY TOWN.COM

WAY TO LOAD TRAILER LEFT SIDE

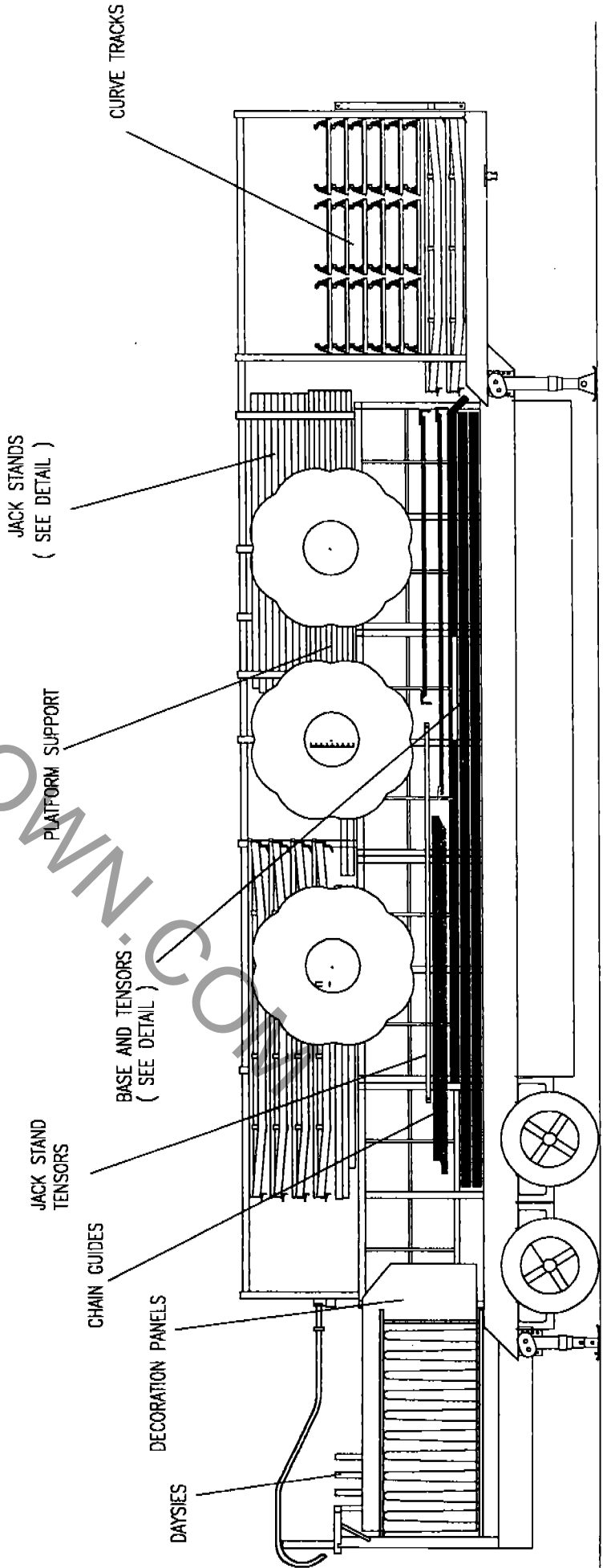

MAIN BOX

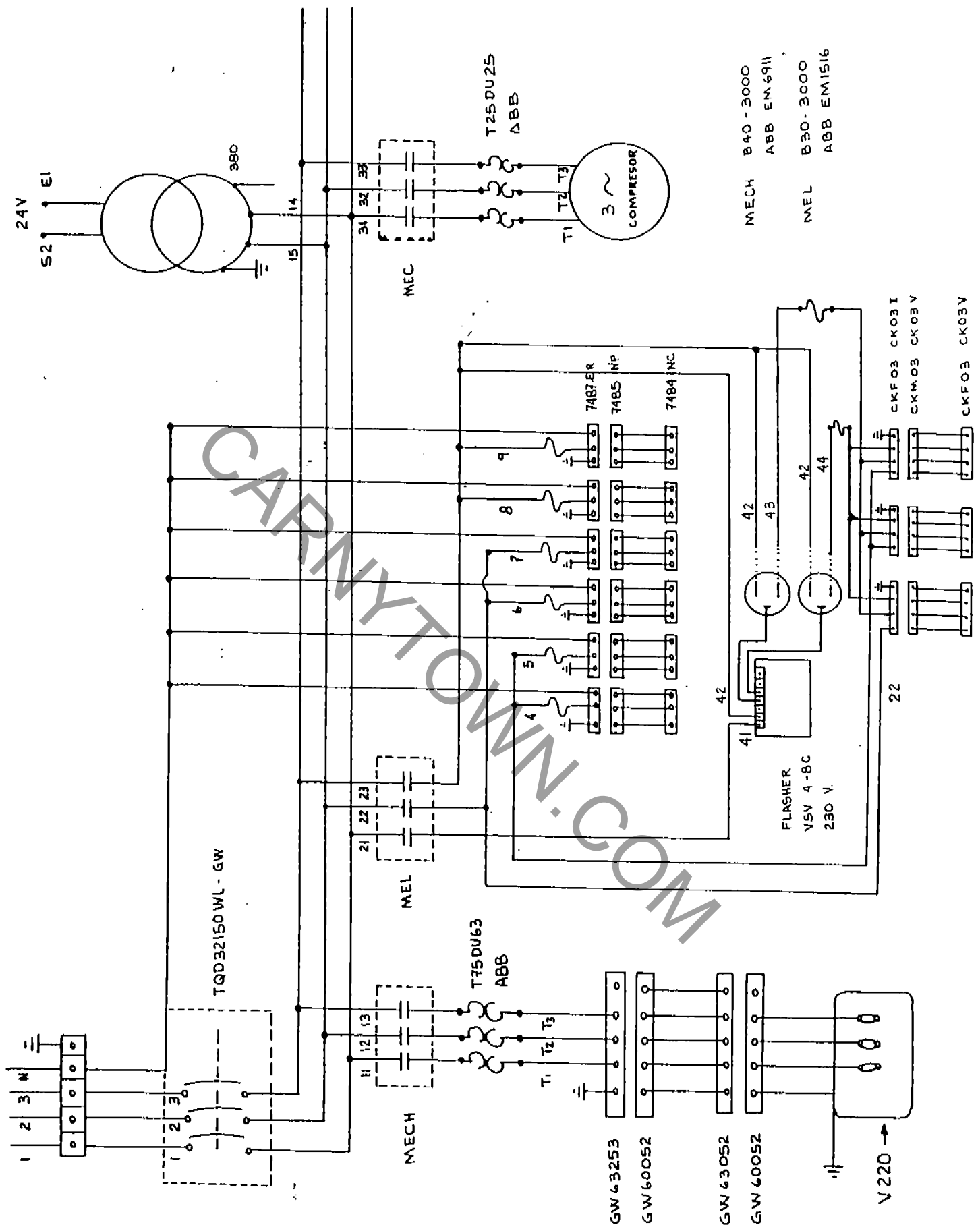

MECH B40-3000  
ABB EM6911

MEL B30-3000  
ABB EM1516

GW 63253

GW 60052

GW 63052

GW 60052

V 220 →



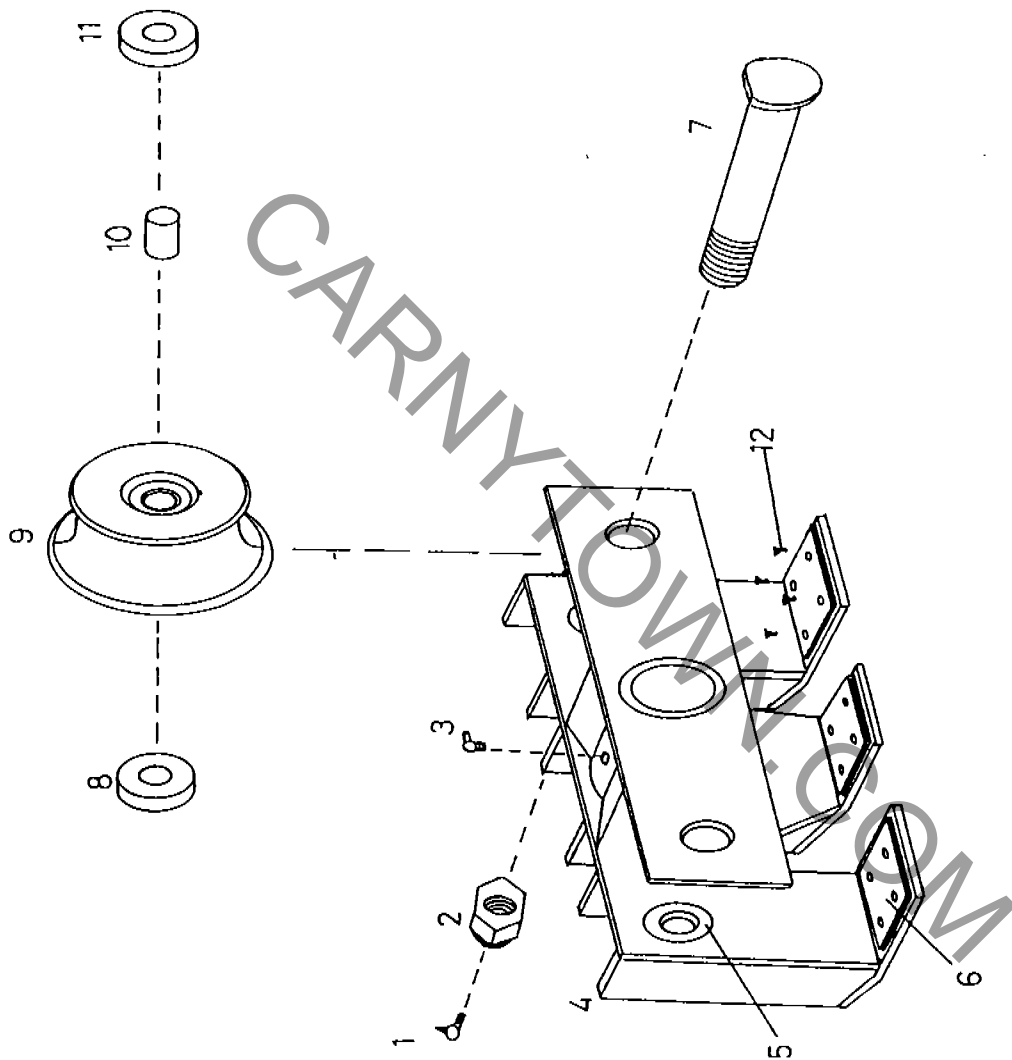

APARATO WACKY WORM  
DIAGRAMA No. 1  
PARTE PATIN

| No. | DESCRIPTION                |
|-----|----------------------------|
| 1   | GRASERA DE PIN             |
| 2   | TUERCA 3/4" ROSCA FINA     |
| 3   | GRASERA DE PATIN           |
| 4   | PATIN                      |
| 5   | BUJE ESCALONADO DE BRONCE  |
| 6   | PLACA NYLON 1/4            |
| 7   | "PIN DE PATINES            |
| 8   | BALERO DE RODO             |
| 9   | RODO NYLON                 |
| 10  | BUJE DE RODO NYLON         |
| 11  | BALERO DE RODO             |
| 12  | REMACHE DE BRONCE DE GOLPE |

WWW.PATINTOWN.COM

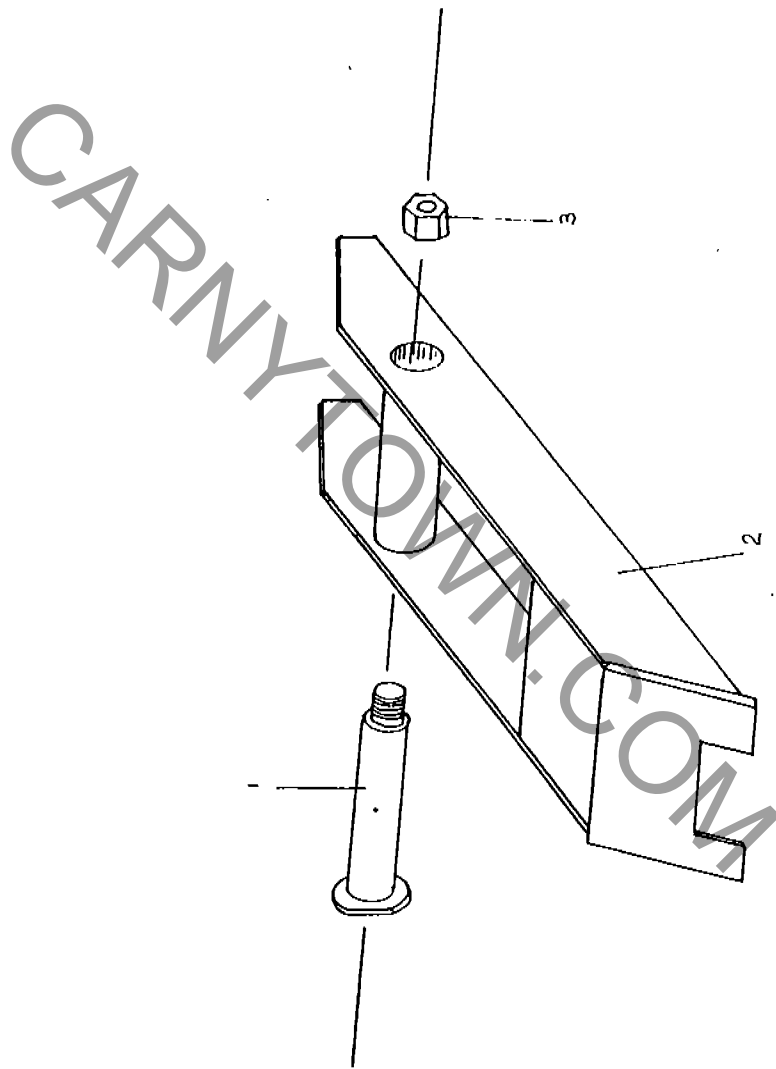

APARATO WACKY WORM  
DIAGRAMA No. 2  
PARTE UÑA DE CADENA

| No. | DESCRIPTION            |
|-----|------------------------|
| 1   | PIN DE UÑA DE CADENA   |
| 2   | UÑA DE CADENA          |
| 3   | TUERCA 3/4" ROSCA FINA |

CARNYTOWN.COM

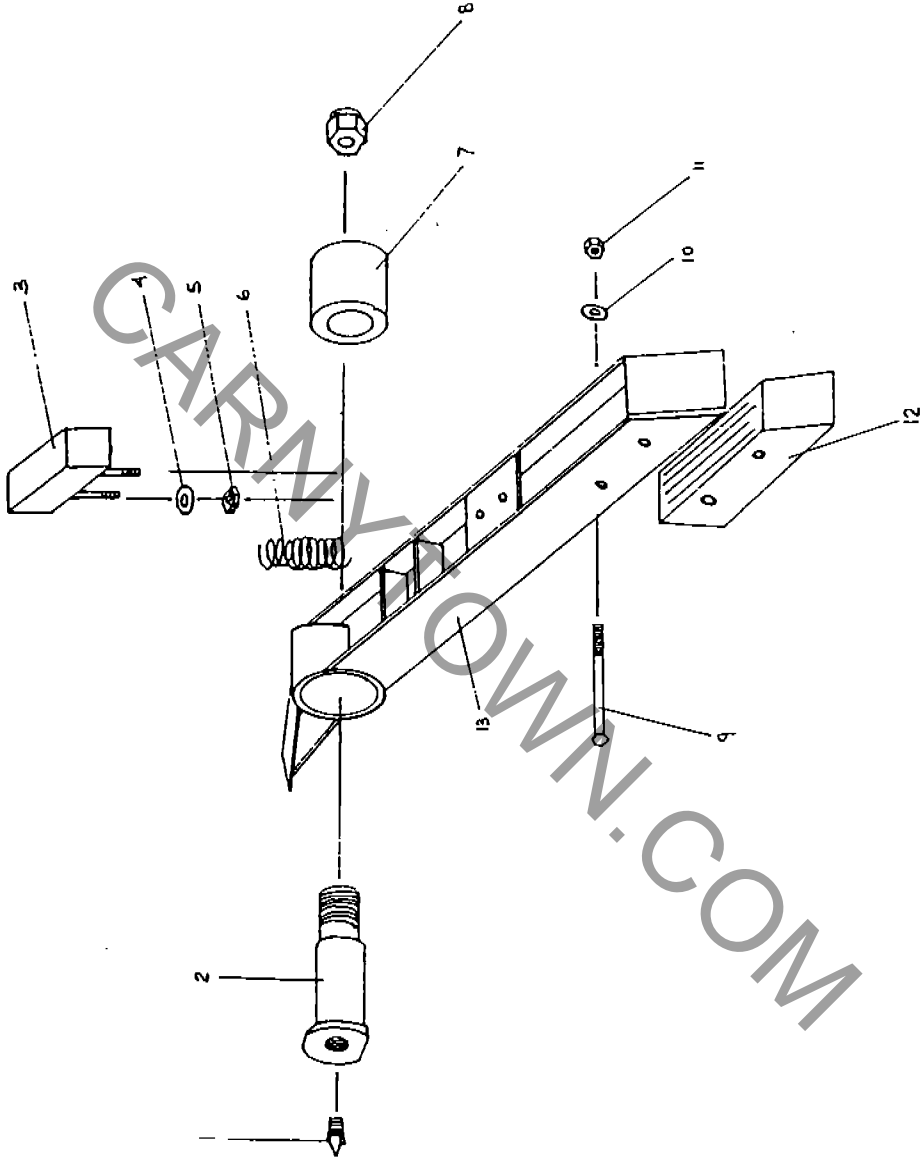
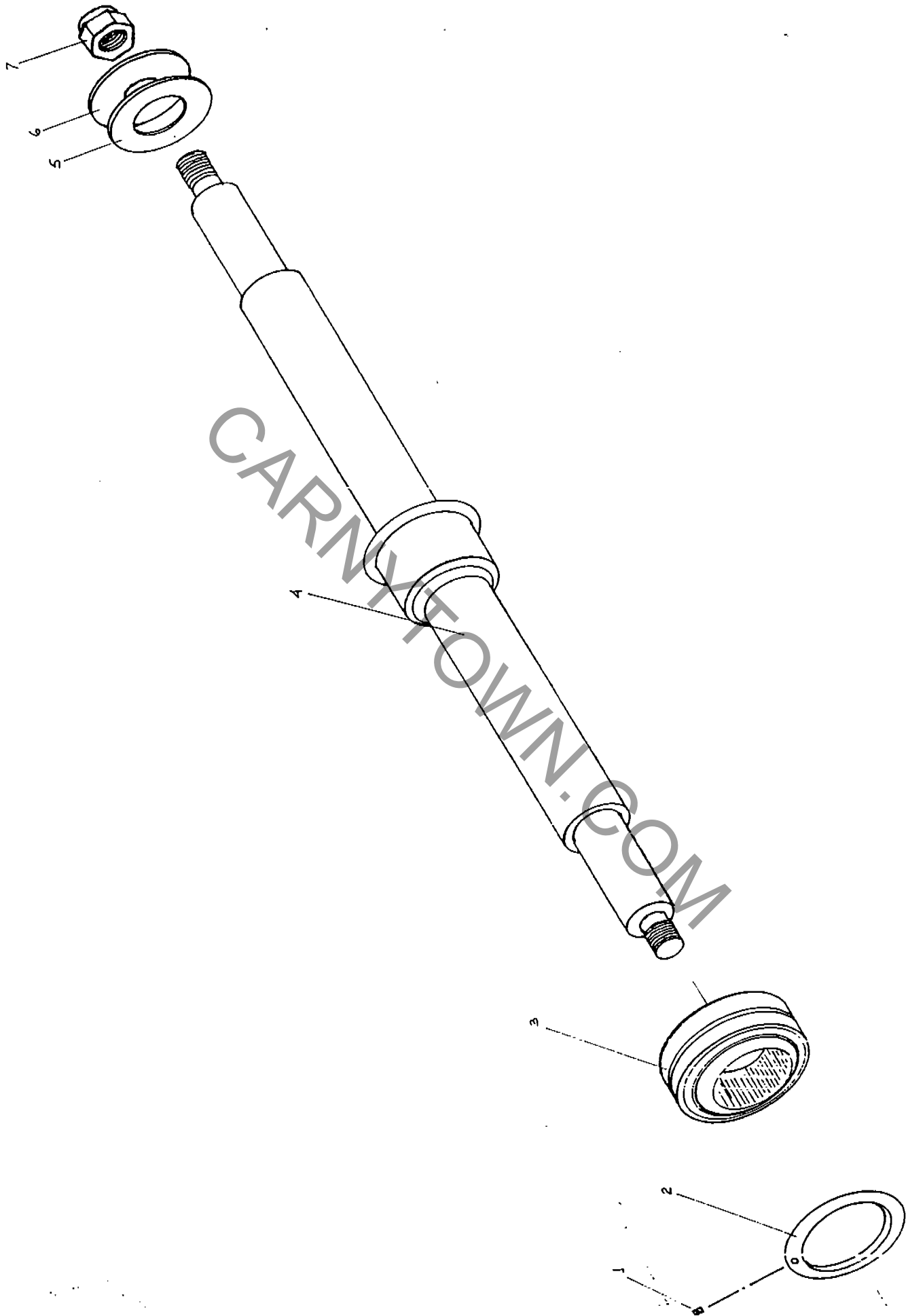

DIAGRAM 3

APARATO WACKY WORM  
DIAGRAMA No. 3  
PARTE UÑA DE SEGURIDAD

| No. | DESCRIPTION                       |
|-----|-----------------------------------|
| 1   | GRASERA                           |
| 2   | PIN DE UÑA DE SEGURIDAD           |
| 3   | HULE SOPORTE CON PERNOS           |
| 4   | ARANDELA PLANA DE 1/4"            |
| 5   | TUERCA 1/4" ROSCA ORDINARIA       |
| 6   | RESORTE DE UÑA SEGURIDAD          |
| 7   | BUJE HIERRO-HULE DE SOPORTE       |
| 8   | TUERCA 3/4" ROSCA FINA            |
| 9   | PERNO 1/4 X 2 ROSCA ORDINARIA     |
| 10  | ARANDELA PLANA DE 1/4"            |
| 11  | TUERCA 1/4" ROSCA ORD.            |
| 12  | SOPORTE INFERIOR DE HULE UÑA SEG. |
| 13  | UÑA DE SEGURIDAD DE COCHIES.      |

OWN.COM



APARATO WACKY WORM  
DIAGRAMA No. 4  
PARTE EJE DELANTERO DE COCHES

| No. | DESCRIPTION                         |
|-----|-------------------------------------|
| 1   | PRISIONERO P/TUERCA DE EJE          |
| 2   | TUERCA PARA EJE DEL.                |
| 3   | BALERO ESFERICO 17SF28              |
| 4   | EJE DELANTERO DE COCHES             |
| 5   | ARANDELA DE BRONCE 1-1/4 DIAM. INT. |
| 6   | ARANDELA DE BRONCE 7/8 DIAM. INT.   |
| 7   | TUERCA DE 1" ROSCA FINA             |

CARNY TOWN.COM

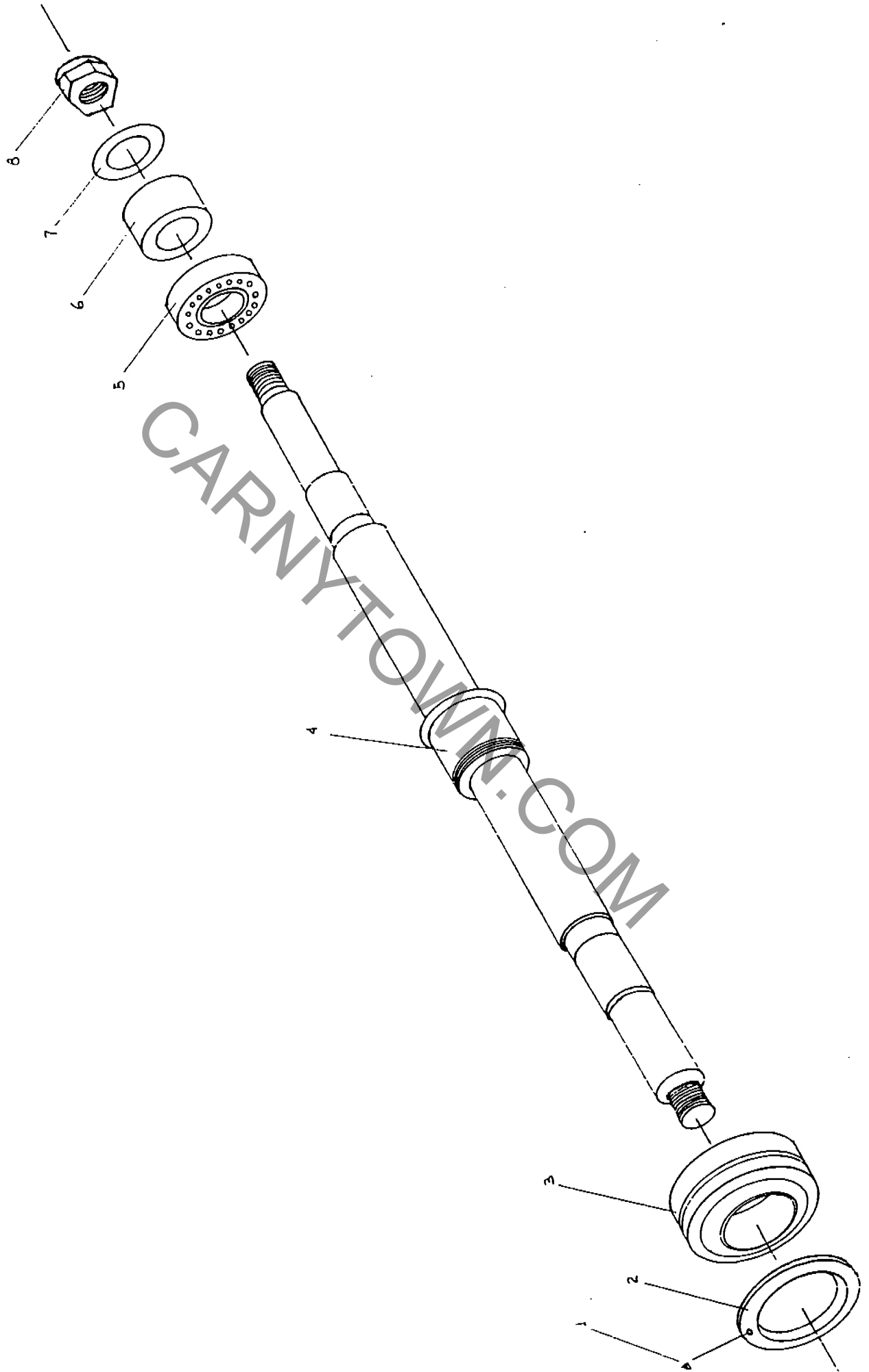

CARNYTOWN.COM

DIAGRAM 5

APARATO WACKY WORM  
DIAGRAMA No. 5  
PARTE EJE TRASERO DE COCHES

| No. | DESCRIPTION                       |
|-----|-----------------------------------|
| 1   | PRISIONERO PARA TUERCA DE EJE     |
| 2   | TUERCA DE EJE TRASERO             |
| 3   | BALERO ESFERICO 17SF28            |
| 4   | EJE TRASERO DE COCHES             |
| 5   | BALERO 6210 SKF                   |
| 6   | SEPARADOR DE EJES TRASEROS        |
| 7   | ARANDELA DE BRONCE 7/8 DIAM. INT. |
| 8   | TUERCA DE EJE DE 1" ROSCA FINA    |

PRINYTOWN.COM

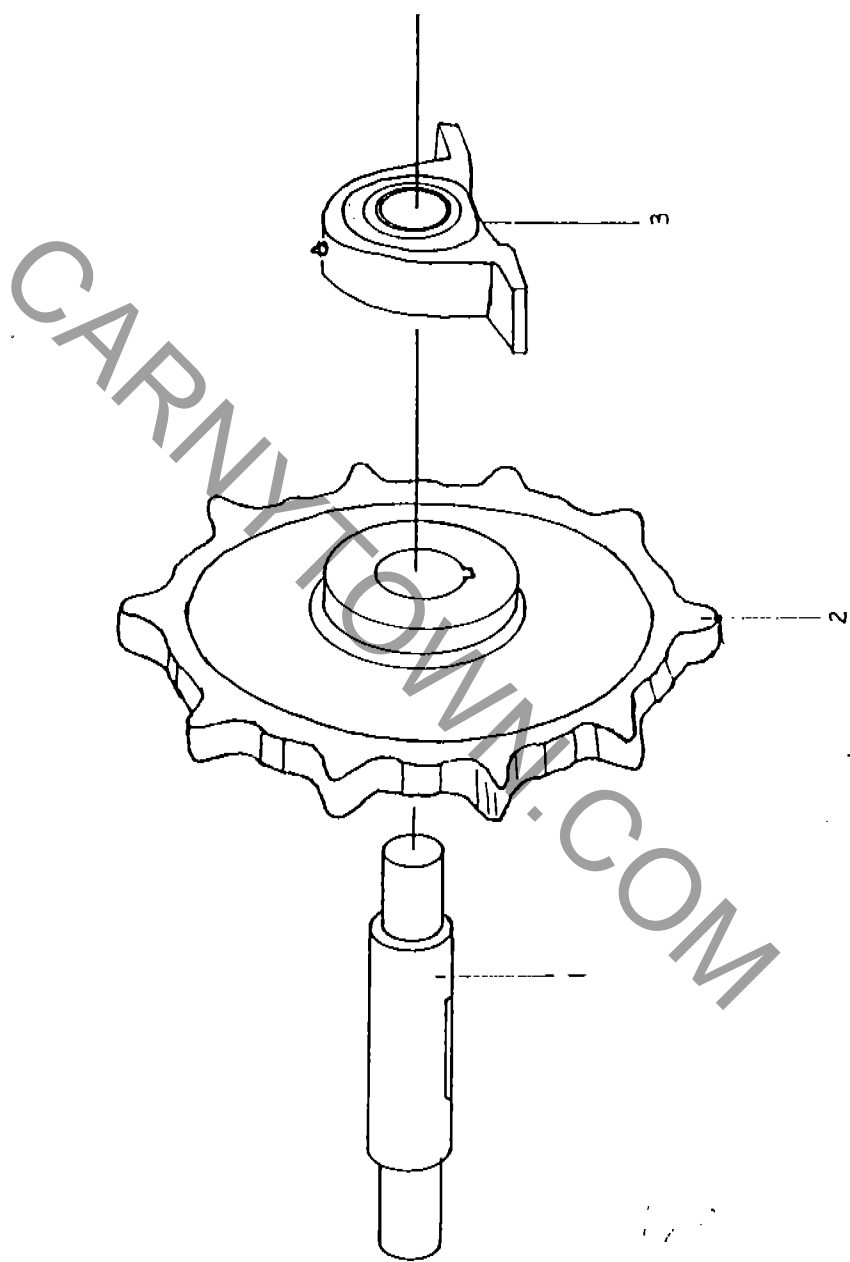

APARATO WACKY WORM  
DIAGRAMA No. 6  
PARTE PIÑON

| No. | DESCRIPTION               |
|-----|---------------------------|
| 1   | EJE DE PIÑON 12-1/4 LONG. |
| 2   | PIÑON DE 10 DIENTES       |
| 3   | CHUMACERA DE BANCO 1-1/4" |

CARNYTOWN.COM

CARNKYTOWN.COM

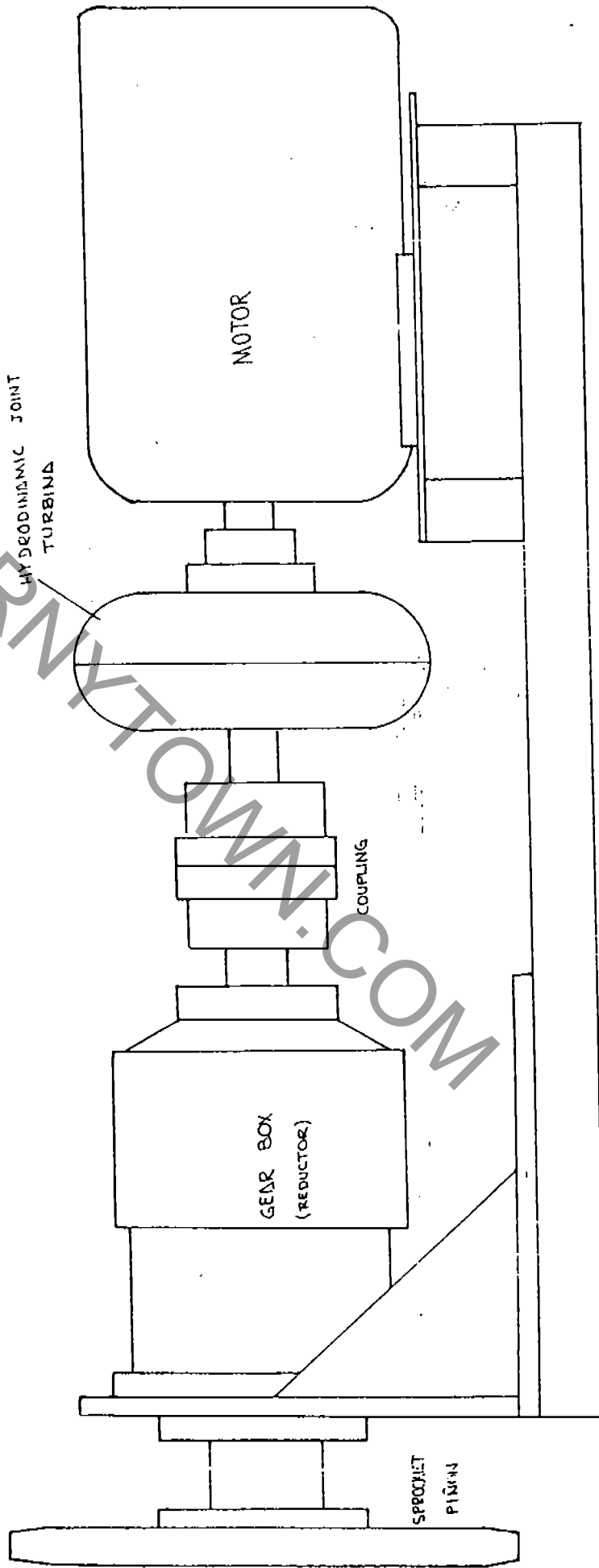



DIAGRAMA 8

APARATO WACKY WORM  
DIAGRAMA No. 8  
PARTE JUNTA O UNION DE COCHES

| No. | DESCRIPTION                  |
|-----|------------------------------|
| 1   | CABLE DE SEGURIDAD           |
| 2   | CHAVETA DE PRESION 5/32      |
| 3   | TUERCA 3/4" ROSCA FINA       |
| 4   | CHUMACERA DOBLE              |
| 5   | PERNO 3/4 X 3-1/2 ROSCA FINA |

CARNY TOWN.COM

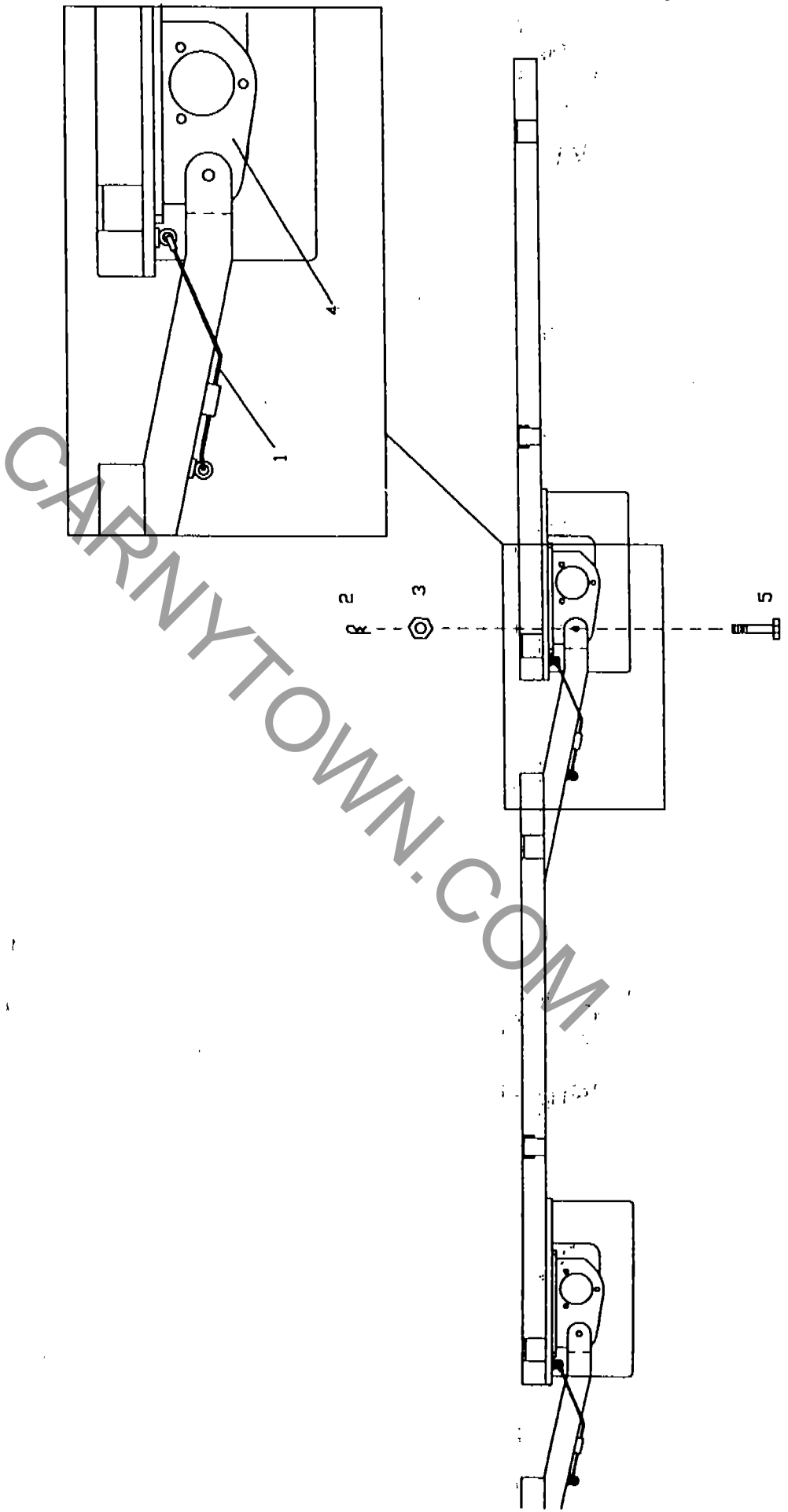
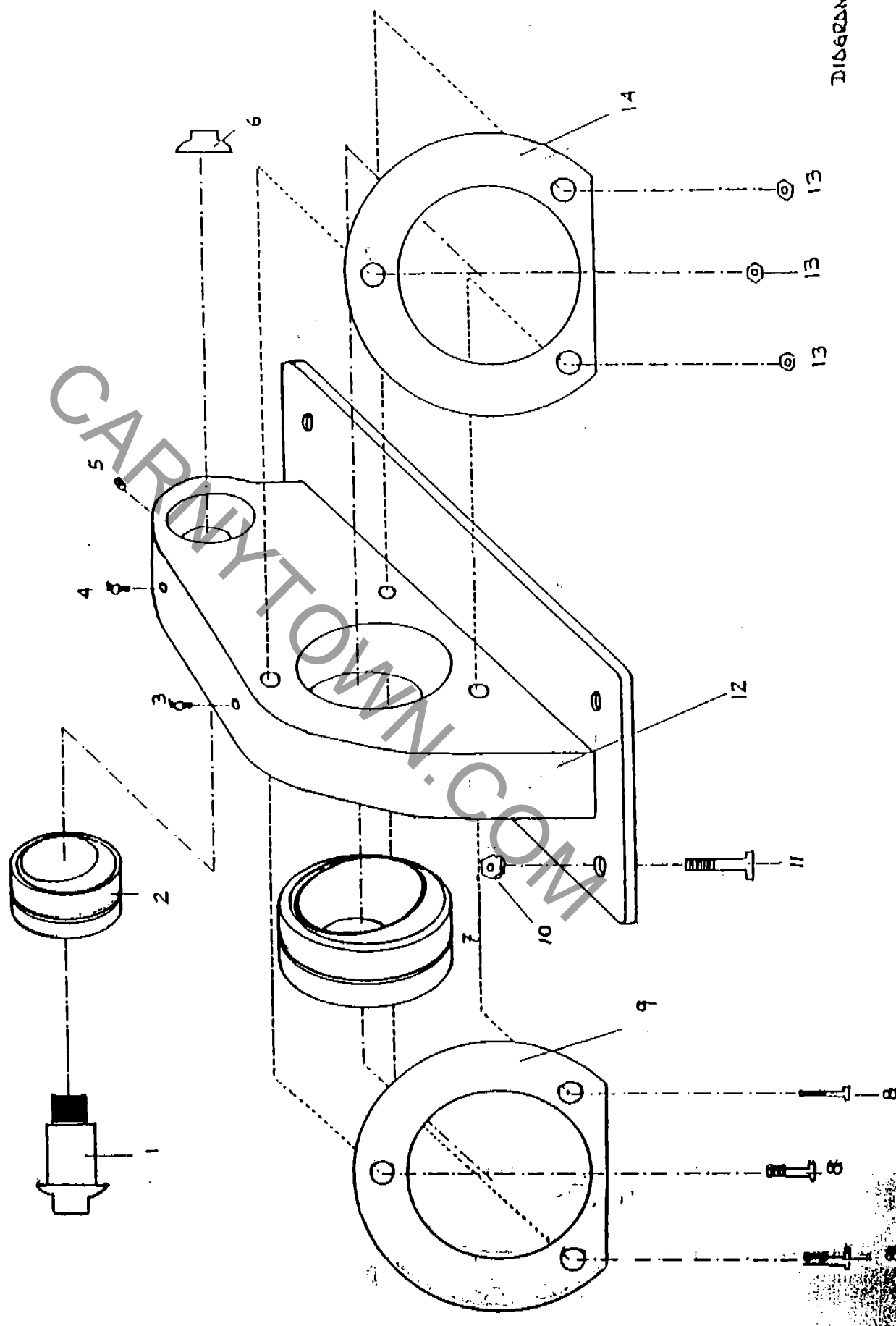

ДИДАГРАМА 9

APARATO WACKY WORM  
DIAGRAMA No. 9  
PARTE CHUMACERA DOBLE

| No. | DESCRIPTION                       |
|-----|-----------------------------------|
| 1   | BUJE DE UNION DE COCHES           |
| 2   | BALERO ESFERICO 12SF20 TORRINGTON |
| 3   | GRASERA DE 1/8"                   |
| 4   | GRASERA DE 1/8"                   |
| 5   | PRISIONERO 1/4" P/ BUJE DE UNION. |
| 6   | TUERCA PARA BUJE DE UNION.        |
| 7   | BALERO ESFERICO 17SF28 TORRINGTON |
| 8   | PERNO 3/8" X 2-1/2                |
| 9   | ARANDELA DE SEGURIDAD DE 1/2"     |
| 10  | TUERCA DE 1/2" ROSCA ORD.         |
| 11  | PERNO 1/2 X 3                     |
| 12  | CHUMACERA DOBLE                   |
| 13  | TUERCA 3/8" ROSCA ORD.            |
| 14  | ARANDELA DE SEGURIDAD DE 1/2"     |

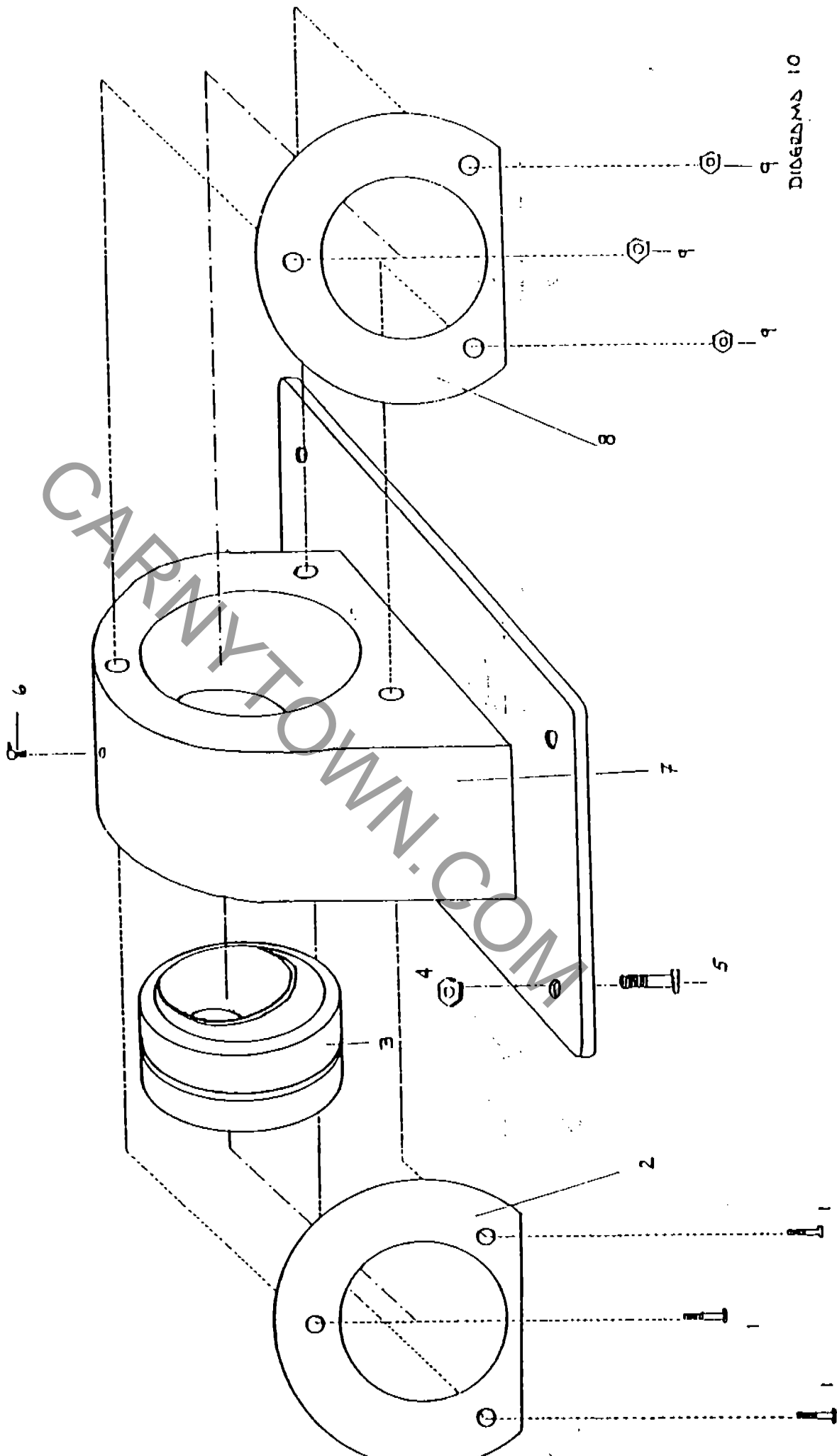

DIAGRAMS 10

APARATO WACKY WORM  
DIAGRAMA No. 10  
PARTE CHUMACERA SENCILLA

| No. | DESCRIPTION                       |
|-----|-----------------------------------|
| 1   | PERNO 3/8 X 3                     |
| 2   | ARANDELA DE SEGURIDAD DE 1/4"     |
| 3   | BALERO ESFERICO 17SF28 TORRINGTON |
| 4   | TUERCA DE 1/2" ROSCA ORD.         |
| 5   | PERNO 1/2 X 3" ORD.               |
| 6   | GRASERA 1/8"                      |
| 7   | CHUMACERA SENCILLA                |
| 8   | ARANDELA DE SEGURIDAD DE 1/4"     |
| 9   | TUERCA 3/8" ORD.                  |

NYTOWN.COM

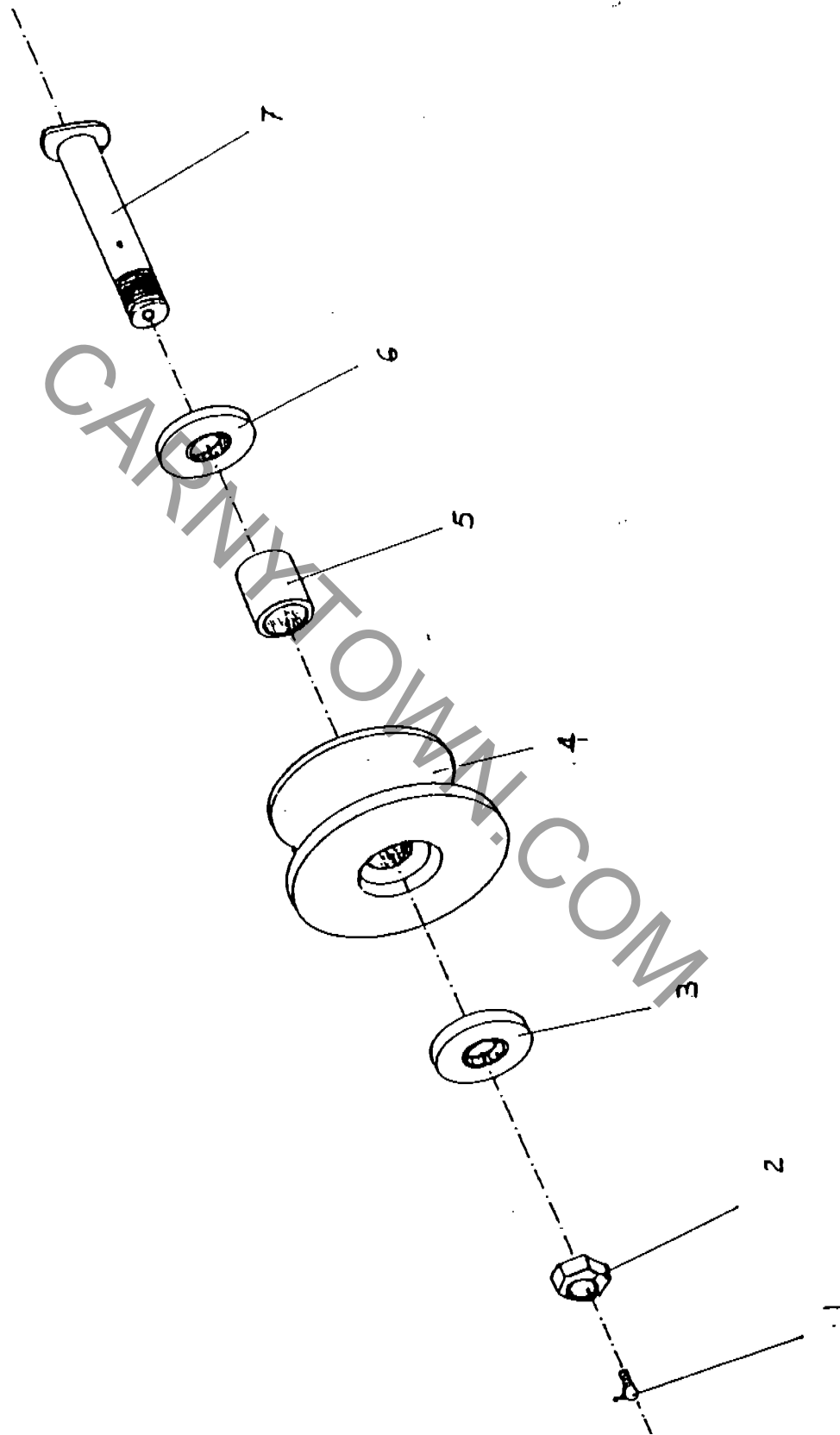

DIAGRAM 11

APARATO WACKY WORM  
DIAGRAMA No. 11  
PARTE RODO DE NYLON

| No. | DESCRIPTION                      |
|-----|----------------------------------|
| 1   | GRASERA DE 1/8"                  |
| 2   | TUERCA DE SEGURIDAD 3/4" R. FINA |
| 3   | BALERO PLANO 6304 SKF            |
| 4   | RODO DE NYLON                    |
| 5   | SEPARADOR DE RODO                |
| 6   | BALERO PLANO 6304 SKF            |
| 7   | PIN DE RODO                      |

ARMYTOWN.COM



DIAGRAMA 12

APARATO WACKY WORM  
DIAGRAMA No. 12  
PARTE LAPBAR DELANTERO

| No. | DESCRIPTION                       |
|-----|-----------------------------------|
| 1   | HERRAJE DELANTERO                 |
| 2   | CHAVETA DE ABRIR P/ PIN DE CLEVIS |
| 3   | BUJE DE BRONCE 5/8" EXT.          |
| 4   | BUJE DE BRONCE 1/2" EXT           |
| 5   | UÑA DE SEGURIDAD DEL.             |
| 6   | PIN DE CLEVIS                     |
| 7   | VARILLA 5/16 DEL.                 |
| 8   | TUERCA 5/16 PARA ESPARRAGO        |
| 9   | ESPARRAGO PARA CILINDRO           |
| 10  | LAPBAR DEL.                       |
| 11  | PERNOS 3/8" UNC                   |
| 12  | OREJA DELANTERA                   |
| 13  | ESPARRAGO PARA CILINDRO           |
| 14  | CILINDRO DE AIRE 50 LBS.          |
| 15  | SEGURO PARA CILINDRO              |
| 16  | SEGURO PARA CILINDRO              |

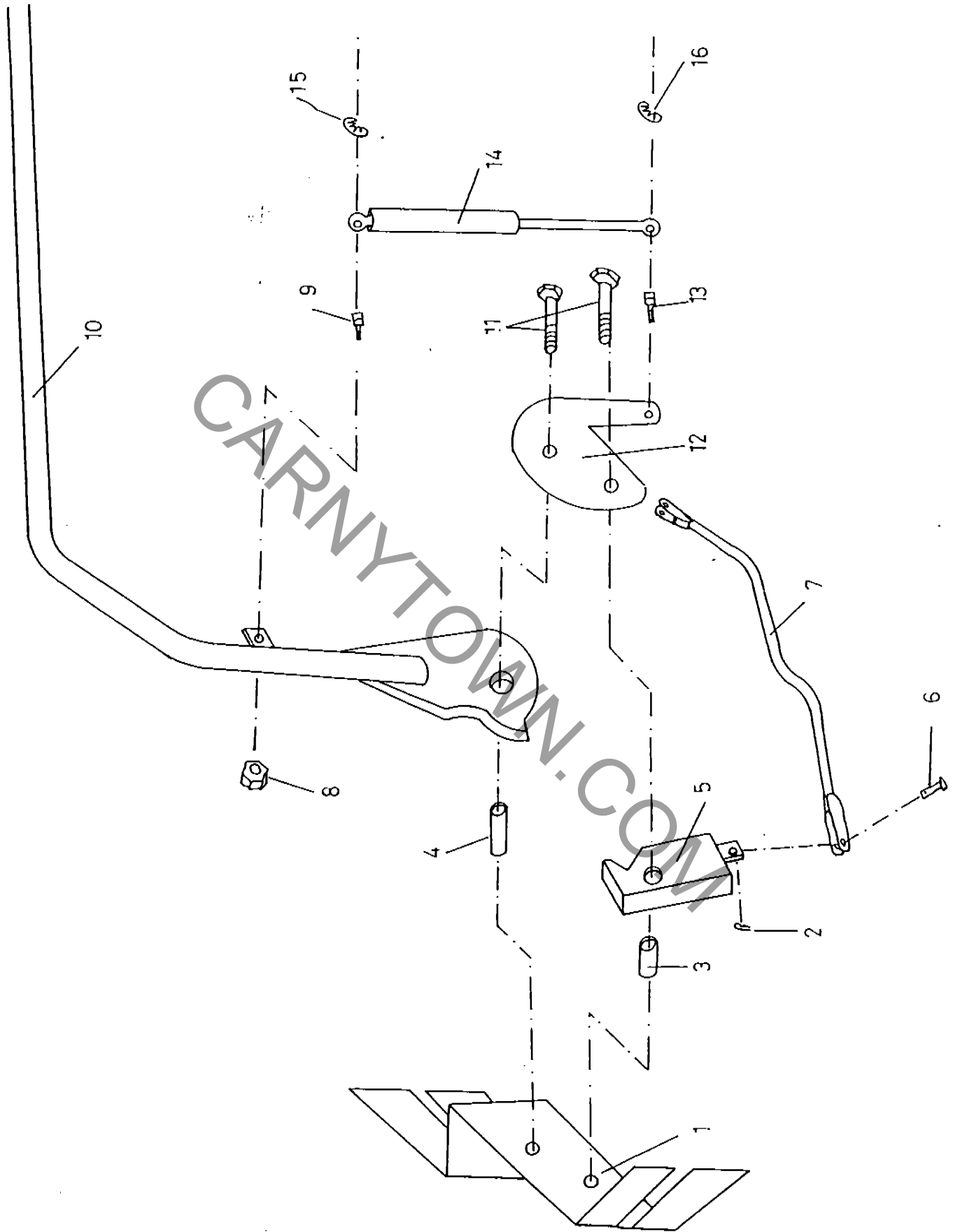
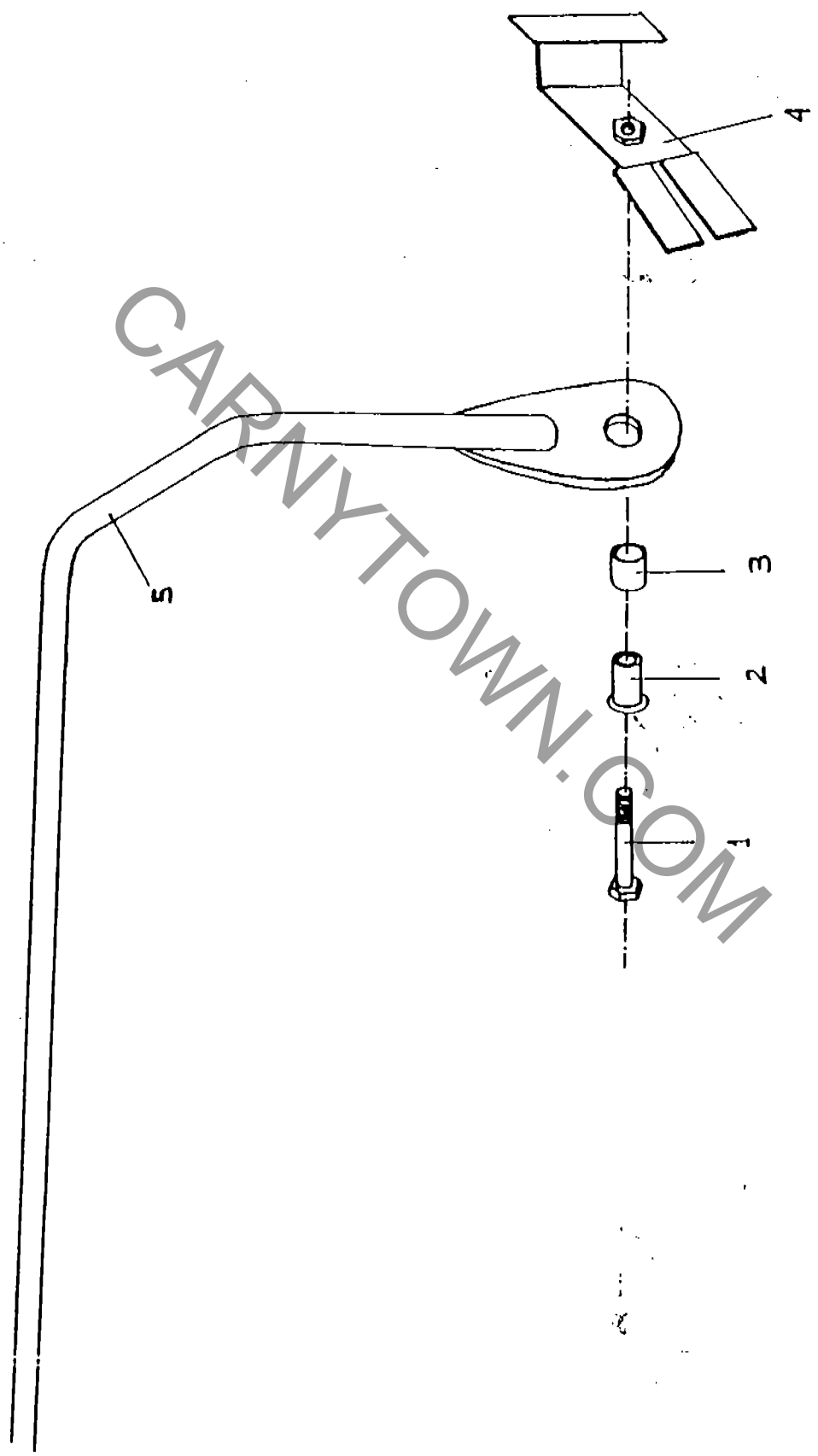

DIGERWA 12-4

APARATO WACKY WORM  
DIAGRAMA No. 12-A  
PARTE LAPBAR DELANTERO

| No. | DESCRIPTION                     |
|-----|---------------------------------|
| 1   | PERNO 3/8" R. ORD.              |
| 2   | BUJE CON GRADA 3/4" EXT. BRONCE |
| 3   | BUJE 5/8" EXT. BRONCE           |
| 4   | HERRAJE DELANTERO IZQ.          |
| 5   | LAPBAR DELANTERO                |

CARNYTOWN.COM



DIAGRAMA 13

APARATO WACKY WORM  
DIAGRAMA No. 13  
PARTE LAPBAR TRASERO

| No. | DESCRIPTION                       |
|-----|-----------------------------------|
| 1   | HERRAJE TRASERO DERECHO           |
| 2   | BUJE DE BRONCE 5/8" EXT.          |
| 3   | UÑA DE SEGURIDAD TRASERA          |
| 4   | CHAVETA DE ABRIR DE PIN DE CLEVIS |
| 5   | VARILLA TRASERA DE 5/16"          |
| 6   | PIN DE CLEVIS                     |
| 7   | BUJE DE BRONCE 3/4"               |
| 8   | TUERCA PARA ESPARRAGO 5/16"       |
| 9   | ESPARRAGO PARA CILINDRO           |
| 10  | OREJA TRASERA                     |
| 11  | PERNOS 3/8" UNC                   |
| 12  | ESPARRAGO PARA CILINDRO           |
| 13  | CILINDRO 50 LBS.                  |
| 14  | SEGURO PARA CILINDRO              |
| 15  | SEGURO PARA CILINDRO              |
| 16  | LAPBAR TRASERO                    |

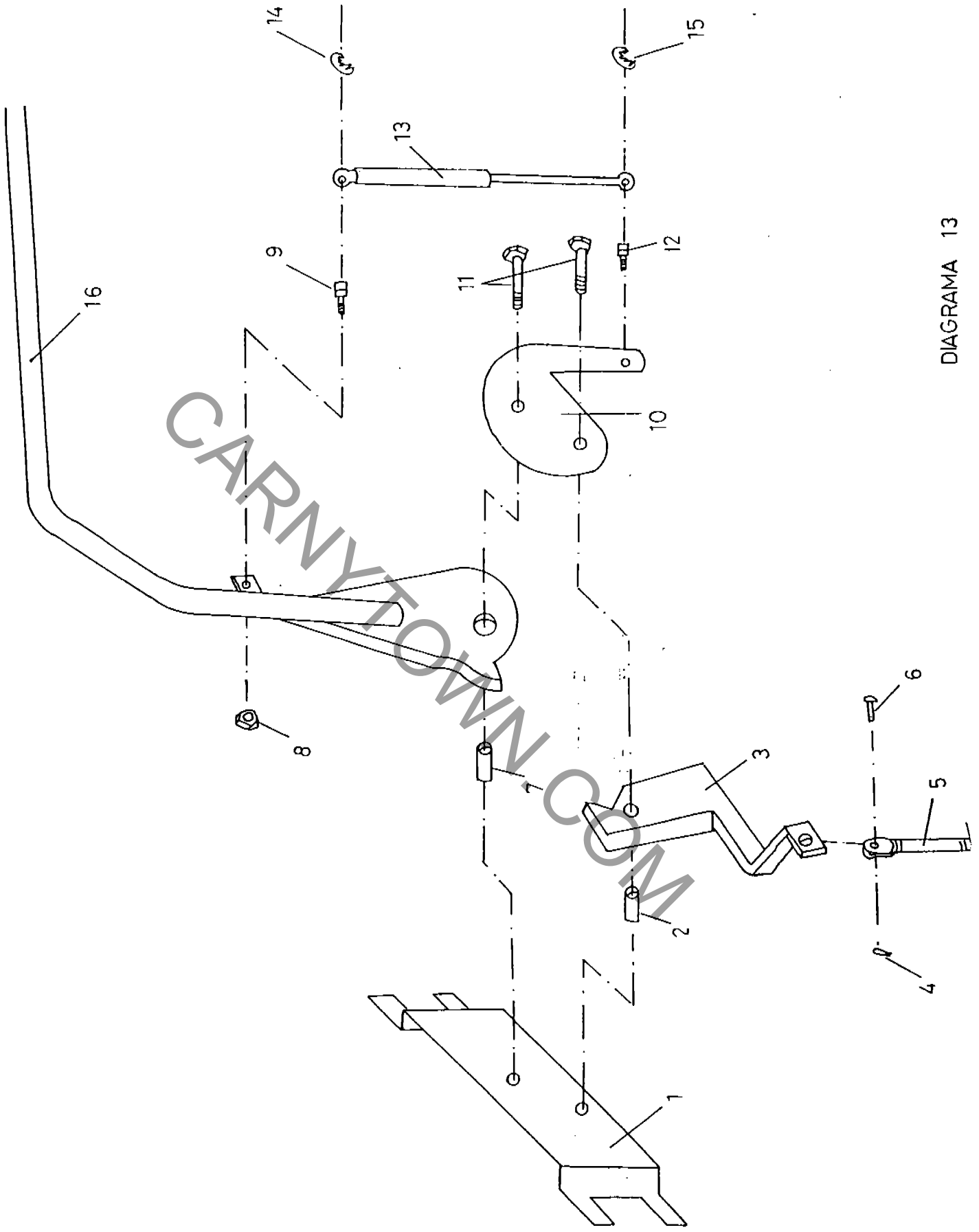
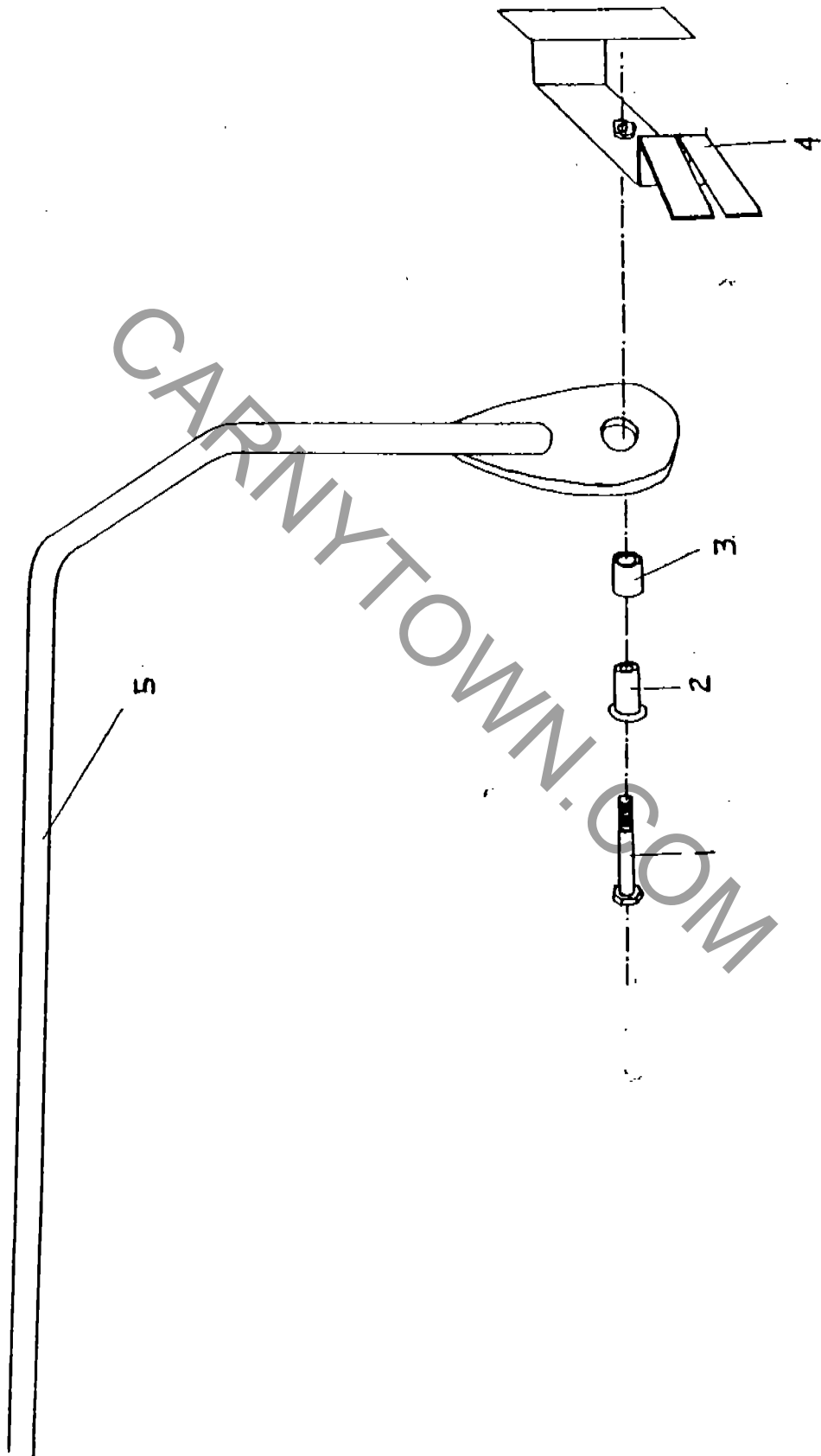

DIAGRAM 13-A

APARATO WACKY WORM  
DIAGRAMA No. 13-A  
PARTE LAPBAR TRASERO

| No. | DESCRIPTION                     |
|-----|---------------------------------|
| 1   | PERNO 3/8" R. ORD.              |
| 2   | BUJE CON GRADA 5/8" EXT. BRONCE |
| 3   | BUJE 3/4" EXT. BRONCE           |
| 4   | HERRAJE TRASERO IZQ             |
| 5   | LAPBAR TRASERO.                 |

CARNYTOWN.COM